



Recommendation ITU-R F.387-12
(03/2012)

**Radio-frequency channel arrangements for
fixed wireless systems operating
in the 10.7-11.7 GHz band**

F Series
Fixed service

Foreword

The role of the Radiocommunication Sector is to ensure the rational, equitable, efficient and economical use of the radio-frequency spectrum by all radiocommunication services, including satellite services, and carry out studies without limit of frequency range on the basis of which Recommendations are adopted.

The regulatory and policy functions of the Radiocommunication Sector are performed by World and Regional Radiocommunication Conferences and Radiocommunication Assemblies supported by Study Groups.

Policy on Intellectual Property Right (IPR)

ITU-R policy on IPR is described in the Common Patent Policy for ITU-T/ITU-R/ISO/IEC referenced in Annex 1 of Resolution ITU-R 1. Forms to be used for the submission of patent statements and licensing declarations by patent holders are available from <http://www.itu.int/ITU-R/go/patents/en> where the Guidelines for Implementation of the Common Patent Policy for ITU-T/ITU-R/ISO/IEC and the ITU-R patent information database can also be found.

Series of ITU-R Recommendations

(Also available online at <http://www.itu.int/publ/R-REC/en>)

Series	Title
BO	Satellite delivery
BR	Recording for production, archival and play-out; film for television
BS	Broadcasting service (sound)
BT	Broadcasting service (television)
F	Fixed service
M	Mobile, radiodetermination, amateur and related satellite services
P	Radiowave propagation
RA	Radio astronomy
RS	Remote sensing systems
S	Fixed-satellite service
SA	Space applications and meteorology
SF	Frequency sharing and coordination between fixed-satellite and fixed service systems
SM	Spectrum management
SNG	Satellite news gathering
TF	Time signals and frequency standards emissions
V	Vocabulary and related subjects

Note: This ITU-R Recommendation was approved in English under the procedure detailed in Resolution ITU-R 1.

Electronic Publication
Geneva, 2012

© ITU 2012

All rights reserved. No part of this publication may be reproduced, by any means whatsoever, without written permission of ITU.

RECOMMENDATION ITU-R F.387-12

Radio-frequency channel arrangements for fixed wireless systems operating in the 10.7-11.7 GHz band

(Question ITU-R 247/5)

(1963-1970-1974-1978-1986-1990-1992-1995-1999-2002-2006-2010-2012)

Scope

This Recommendation provides radio-frequency channel arrangements for fixed wireless systems (FWSs) operating in the 11 GHz band (10.7-11.7 GHz), which may be used for high, medium and low capacity fixed service applications including mobile infrastructure. The channel spacing recommended in the main text is 40 MHz with 15 and 55 MHz guardbands as well as a second arrangement also using a channel spacing of 40 MHz but with a 35 MHz guardband. Arrangements with channel spacings other than 40 MHz and used in some countries are also provided in the *recommends* referring to several annexes.

The ITU Radiocommunication Assembly,

considering

- a) that, at 11 GHz, digital systems with a capacity of up to 140 Mbit/s or synchronous digital hierarchy or equivalent bit rates seem to be feasible, subject to rainfall conditions;
- b) that repeater spacing as well as other aspects of system design in this frequency range must take due cognizance of significant meteorological factors;
- c) that it is desirable to interconnect such systems at radio frequencies on international links;
- d) that single- and multi-carrier digital fixed wireless systems (FWSs) are both useful concepts to achieve the best technical and operational trade-off in system design;
- e) that when very high-capacity links (e.g. twice Synchronous Transfer Mode-1 (STM-1)) are required, further economy may be achieved using system bandwidths wider than the recommended channel separation, associated to highly efficient modulation formats,

recommends

1 that the preferred RF channel arrangements for high capacity FWS with a bit rate of the order of plesiochronous or synchronous digital hierarchy or equivalent bit rates (see Note 1) operating in the 11 GHz band should be derived as follows:

Let f_0 be the frequency of the centre of the band of frequencies occupied (MHz),

f_n be the centre frequency of one RF channel in the lower half of the band (MHz),

f'_n be the centre frequency of one RF channel in the upper half of the band (MHz);

1.1 that a main pattern (providing up to 12 go and return channels) provides the frequencies of individual channels expressed by the following relationship:

lower half of the band: $f_n = f_0 - 525 + 40 n$ MHz

upper half of the band: $f'_n = f_0 + 5 + 40 n$ MHz

where:

$n = 1, 2, 3, \dots 12$ in both the lower and the upper bands (for 12-channel arrangement with ZS¹ guardbands of 15 MHz),

or $n = 2, 3, 4, \dots 12$ in the lower half of the band, and

$n = 1, 2, 3, \dots 11$ in the upper half of the band (for 11-channel arrangement with ZS¹ guardbands of 55 MHz).

The frequency arrangement is illustrated in Fig. 1 (Note 2); alternated, co-polar and frequency reuse arrangements are possible;

1.2 that a second option for main pattern (providing up to 12 go and return channels) with ZS¹ guardbands of 35 MHz provides the frequencies of individual channels expressed by the following relationship:

$$\text{lower half of the band: } f_n = f_0 - 505 + 40 n \quad \text{MHz}$$

$$\text{upper half of the band: } f'_n = f_0 - 15 + 40 n \quad \text{MHz}$$

where:

$n = 1, 2, 3, \dots 12$, depending on the number of channels.

The frequency arrangement is illustrated in Fig. 2, alternated, co-polar and frequency reuse arrangements are possible;

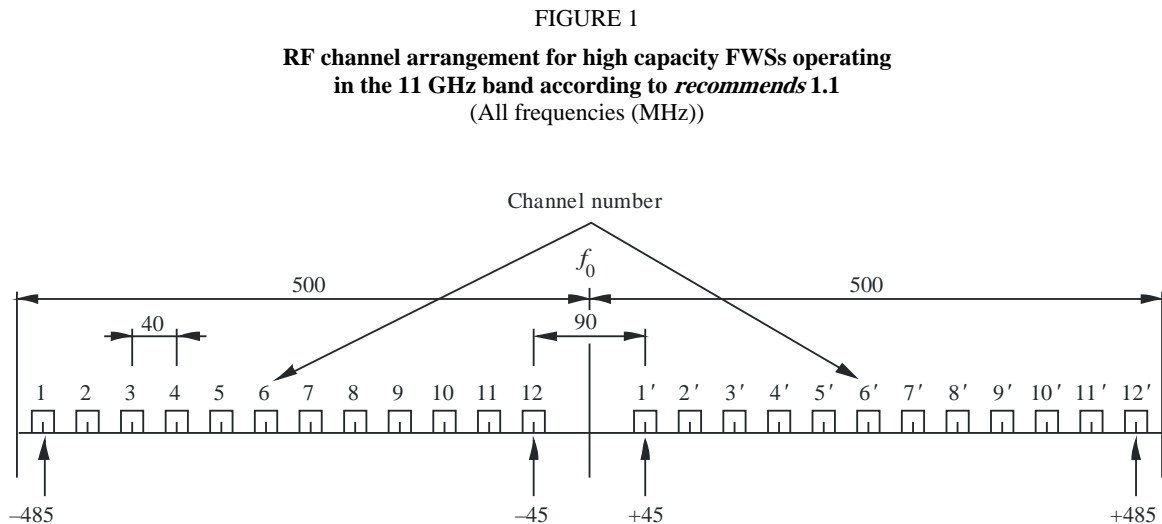

¹ ZS defined as the radio-frequency separation between the centre frequencies of the outermost radio-frequency channels and the edge of the frequency band.

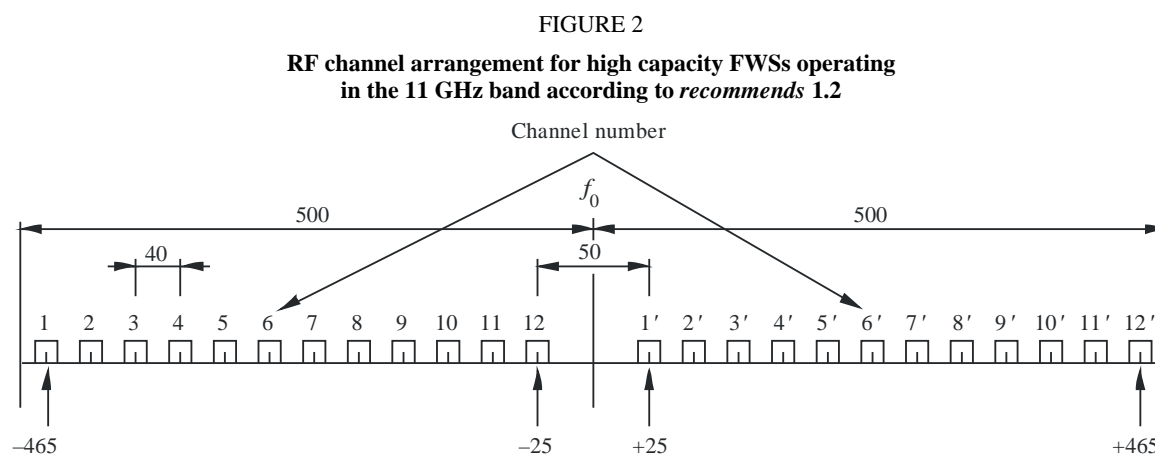

F.0387-02

1.3 that when very high-capacity links (e.g. twice STM-1) are required and network coordination permits, with the agreement of the administrations concerned, the use of any two adjacent 40 MHz channels specified in *recommends 1.1* or *recommends 1.2* is possible, for wider bandwidth systems, with the centre frequency lying in the central point of the distance between the two 40 MHz adjacent channels;

2 that, in a section over which the international connection is arranged, all the go channels should be in one half of the band and all the return channels should be in the other half of the band;

3 that for adjacent RF channels in the same half of the band different polarizations should preferably be used alternately (see *recommends 6*);

4 that the preferred centre frequency f_0 is 11 200 MHz; other centre frequencies may be used by agreement between the administrations concerned;

5 that when low or medium-capacity digital FWS are to be used in the 11 GHz band, the RF channel arrangement should be in accordance with the pattern in *recommends 1.2* (see Note 5);

6 that a co-channel dual polarized arrangement may also be used for digital FWS which can be derived from the arrangements given in Figs 1 or 2 by supplementing each channel by its counterpart;

7 that if multi-carrier transmission (see Note 3) is employed, the overall number of n carriers will be regarded as a single channel. The centre frequency of that channel should be derived from those referred to in *recommends 1*, disregarding the actual centre frequencies of the individual carriers, which may vary, for technical reasons, according to practical implementations. Operation of multi-carrier systems is addressed in greater detail in Annex 1.

NOTE 1 – Actual gross bit rates may be as much as 5% or more higher than net transmission bit rates.

NOTE 2 – Due regard should be taken that Channels 1 and 12' of this arrangement are centred only 15 MHz apart from the band edges; therefore, limitation in the system bandwidth may be present. In addition, another interleaved channel arrangement with radio-frequency channels shifted 20 MHz below the main pattern in *recommends 1.1* was also recommended in the previous version of this Recommendation and used in particular in the past for the introduction of digital medium capacity networks in addition to existing analogue ones. Channel 1 of this interleaved arrangement was outside the lower band edge, at 10.7 GHz, and in accordance with No. 5.340 of the Radio

Regulations (RR), its use is prohibited; however, in accordance with RR No. 5.483, this arrangement may still be in use in some countries.

NOTE 3 – A multi-carrier system is a system with n (where $n > 1$) digitally modulated carrier signals simultaneously transmitted (or received) by the same RF equipment. The centre frequency should be regarded as the arithmetic average of the n individual carrier frequencies of the multi-carrier system.

NOTE 4 – Due regard should be taken that in one country a channel arrangement based on 60 MHz channel separation is used. This arrangement is shown in Annex 2.

NOTE 5 – Due regard should be taken of the fact that, in some countries, other RF channel arrangements, based on multiples of 5 MHz channel separation, for medium- and low-capacity digital systems are used. A description of these RF channel arrangements is given in Annex 3.

NOTE 6 – Due regard should be taken that in some countries, other RF channel arrangements based on a 28 MHz channel separation are used. A description of these RF channel arrangements is given in Annex 4.

Annex 1

Description of a multi-carrier system

A multi-carrier system is a system with n (where $n > 1$) digitally modulated carrier signals simultaneously transmitted (or received) by the same radio frequency equipment.

For high capacity multi-carrier transmission, the centre frequency of the channel should coincide with one of the corresponding frequencies of the basic channel arrangements given in *recommends* 1.1 or *recommends* 1.2 or *recommends* 1.3. The channel spacing may be an integer multiple of the basic values defined by *recommends* 1.1 or *recommends* 1.2. Compatibility with existing configurations has to be taken into account when choosing the appropriate alternative.

An example of a co-polar frequency reuse channel arrangement using a two carrier system with 64-QAM is shown in Fig. 3.

The channel arrangement depicted in Fig. 3 is based upon the use of a 2-carrier system transmitting $2 \times 2 \times 155.52$ Mbit/s ($4 \times$ STM-1) via two carrier pairs using both polarizations in the co-channel arrangement.

FIGURE 3

RF channel arrangement for a $2 \times 2 \times 155.52$ Mbit/s (4 STM-1) FWS operating with 80 MHz channel spacing in the 10.7-11.7 GHz band, as used in Switzerland
(All frequencies (MHz))

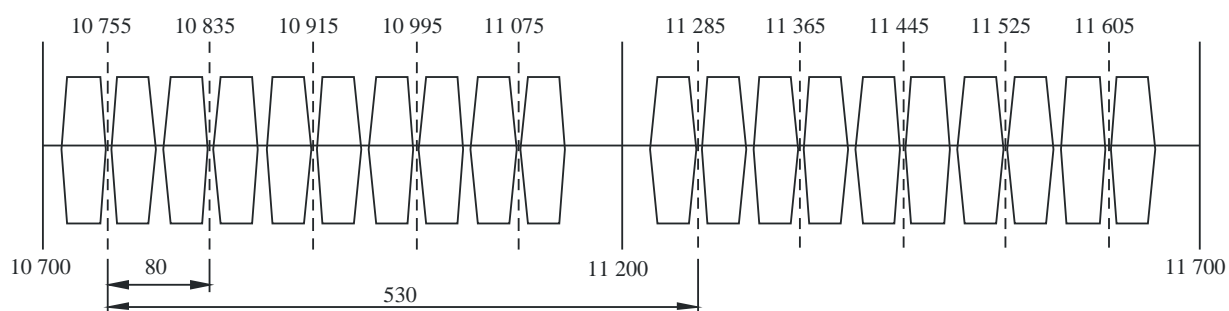

F.0387-03

Annex 2

Description of the 60 MHz RF channel arrangement

The RF channel arrangement referred to in Note 4 providing 16 go and return channels based on co-channel pattern is shown in Fig. 4 and defined as:

$$\text{lower half of the band: } f_n = f_0 - 470 + 60(n - 1) \quad \text{MHz}$$

$$\text{higher half of the band: } f'_n = f_0 + 50 + 60(n - 1) \quad \text{MHz}$$

where:

$$n = 1, 2, \dots, 8.$$

FIGURE 4

RF channel arrangement for high capacity digital FWSs operating in the 11 GHz band
(All frequencies (MHz))

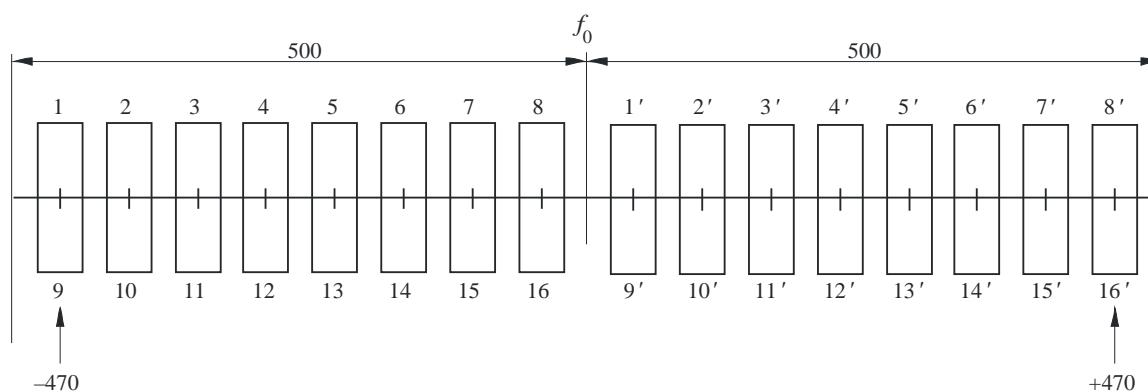

F.0387-04

Annex 3

RF channel arrangements for medium- and low-capacity digital FWS operating in the band 10 700-11 700 MHz with a channel spacing of 20, 10 and 5 MHz

The RF channel arrangements referred to in Note 5 of *recommends* 5 for carrier spacing of 20 MHz, 10 MHz and 5 MHz are shown in Fig. 5 and shall be derived as follows:

Let:

f_0 be the frequency of the centre of the band of frequencies occupied (MHz);

f_n be the centre frequency of one RF channel in the lower half of the band (MHz);

f'_n be the centre frequency of one RF channel in the upper half of the band (MHz);

a) for systems with a carrier spacing of 20 MHz:

lower half of the band: $f_n = f_0 - 505 + 20 n$

upper half of the band: $f'_n = f_0 + 25 + 20 n$

where:

$$n = 1, 2, 3, \dots 23;$$

b) for systems with a carrier spacing of 10 MHz:

lower half of the band: $f_n = f_0 - 505 + 10 n$

upper half of the band: $f'_n = f_0 + 25 + 10 n$

where:

$$n = 1, 2, 3, \dots 47;$$

c) for systems with a carrier spacing of 5 MHz:

lower half of the band: $f_n = f_0 - 500 + 5 n$

upper half of the band: $f'_n = f_0 + 30 + 5 n$

where:

$$n = 1, 2, 3, \dots 93.$$

The centre frequency f_0 is 11 200 MHz.

FIGURE 5

RF arrangements for FWSs operating with 20 MHz, 10 MHz and 5 MHz channel spacing in the 10.7-11.7 GHz

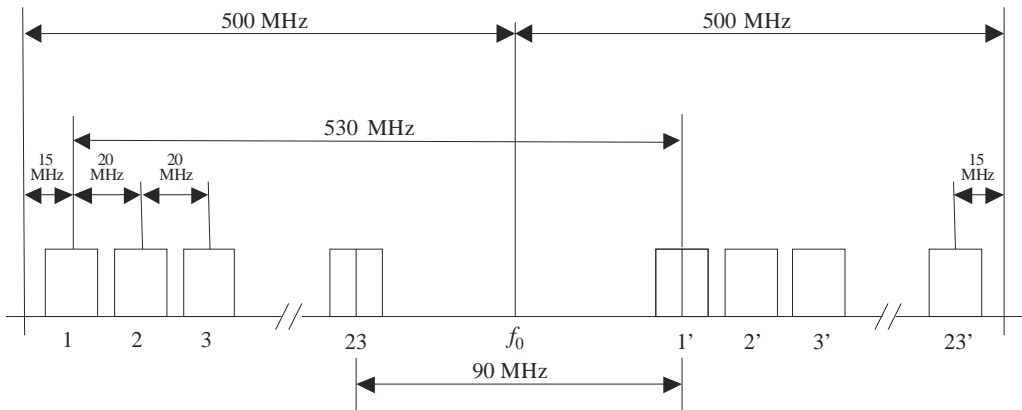

a) For systems with a carrier spacing of 20 MHz

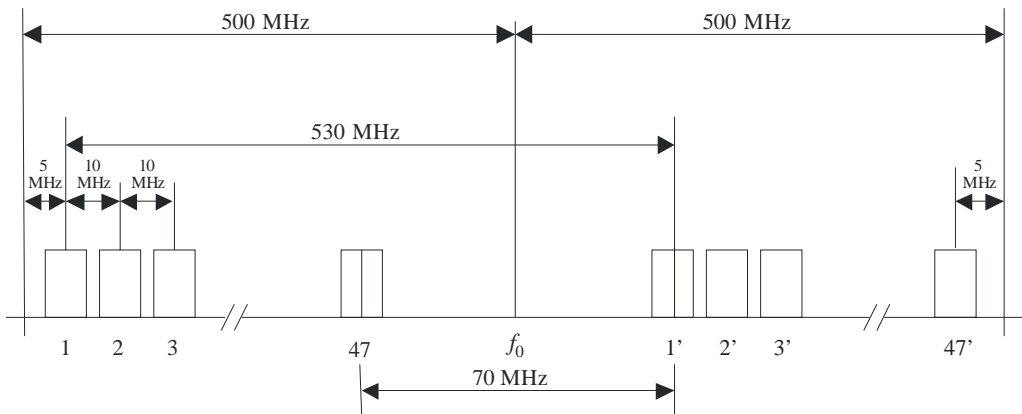

b) For systems with a carrier spacing of 10 MHz

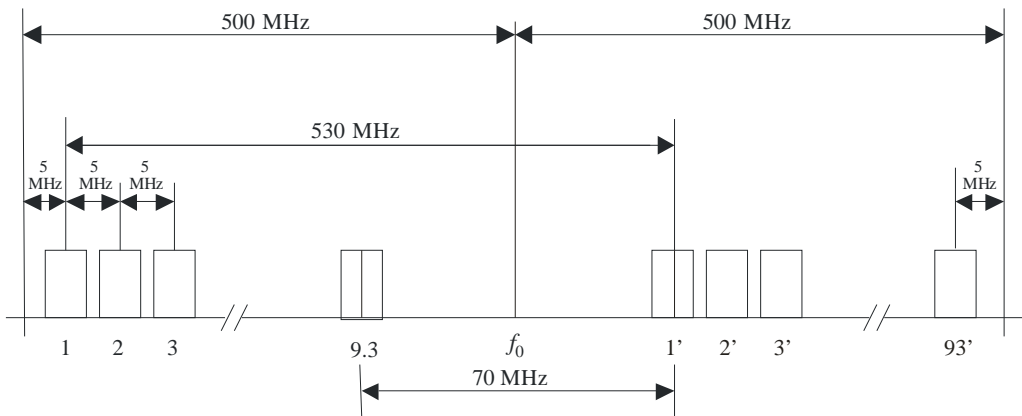

c) For systems with a carrier spacing of 5 MHz

Annex 4

Radio-frequency channel arrangements for digital fixed wireless systems operating in the band 10 700-11 700 MHz with a channel spacing of 28, 14 and 7 MHz

The radio-frequency channel arrangements, referred to in Note 6, for a carrier spacing of 28 MHz, 14 MHz and 7 MHz are shown in Figs 6 and 7 and shall be derived as follows:

Let:

- f_0 be the frequency 11 200 MHz of the centre of the band of frequencies occupied (MHz);
- f_n be the centre frequency of one radio-frequency channel in the lower half of the band (MHz);
- f'_n be the centre frequency of one radio-frequency channel in the upper half of the band (MHz).

1 Arrangements with duplex spacing $X_S = 530$ MHz (Fig. 6)

a) for systems with a carrier spacing of 28 MHz:

$$\text{lower half of band: } f_n = f_0 - 505 + 28 n$$

$$\text{upper half of band: } f'_n = f_0 + 25 + 28 n$$

where:

$$n = 1, 2, \dots 16;$$

b) for systems with a carrier spacing of 14 MHz:

$$\text{lower half of band: } f_n = f_0 - 498 + 14 n$$

$$\text{upper half of band: } f'_n = f_0 + 32 + 14 n$$

where:

$$n = 1, 2, \dots 32;$$

c) for systems with a carrier spacing of 7 MHz:

$$\text{lower half of band: } f_n = f_0 - 494.5 + 7 n$$

$$\text{upper half of band: } f'_n = f_0 + 35.5 + 7 n$$

where:

$$n = 1, 2, \dots 65.$$

2 Arrangements with duplex spacing $X_S = 490$ MHz (Fig. 7)

a) for systems with a carrier spacing of 28 MHz:

$$\text{lower half of band: } f_n = f_0 - 505 + 28 n$$

$$\text{upper half of band: } f'_n = f_0 - 15 + 28 n$$

where:

$$n = 1, 2, \dots 17;$$

b) for systems with a carrier spacing of 14 MHz:

$$\text{lower half of band: } f_n = f_0 - 498 + 14 n$$

$$\text{upper half of band: } f'_n = f_0 - 8 + 14 n$$

where:

$$n = 1, 2, \dots 34;$$

c) for systems with a carrier spacing of 7 MHz:

$$\text{lower half of band: } f_n = f_0 - 494.5 + 7 n$$

$$\text{upper half of band: } f'_n = f_0 - 4.5 + 7 n$$

where:

$$n = 1, 2, \dots 68.$$

NOTE 1 – When very high capacity (e.g. twice STM-1) links are required and the network coordination permits, with the agreement of the administrations concerned, the use of any two adjacent 28 MHz channels specified in a) is possible, for a wider bandwidth system, with the centre frequency lying in the central point of the distance between the two 28 MHz adjacent channels.

FIGURE 6

Radio-frequency arrangements for fixed wireless systems operating with a 28 MHz, 14 MHz and 7 MHz channel spacing and 530 MHz duplex spacing in the 10.7-11.7 GHz band

Transmit (or receive)

Receive (or transmit)

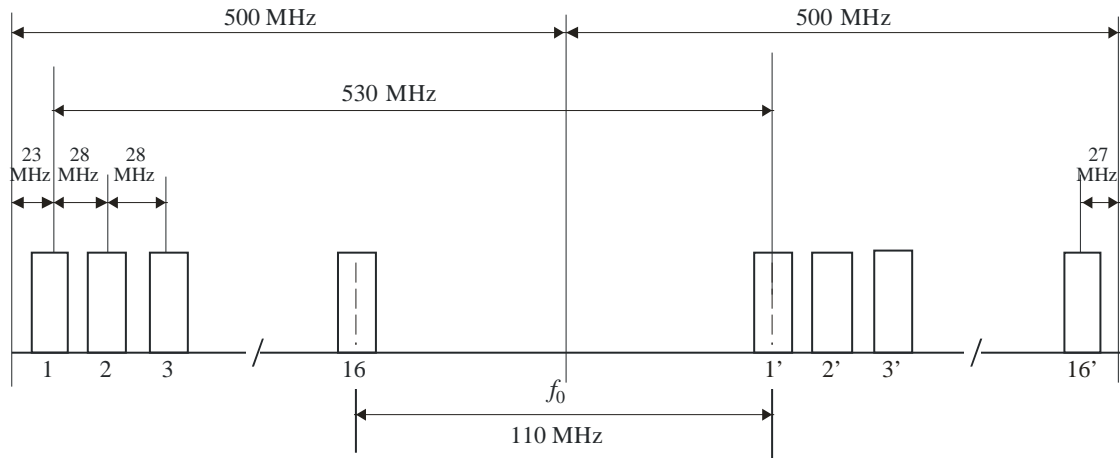

a) for systems with a carrier spacing of 28 MHz

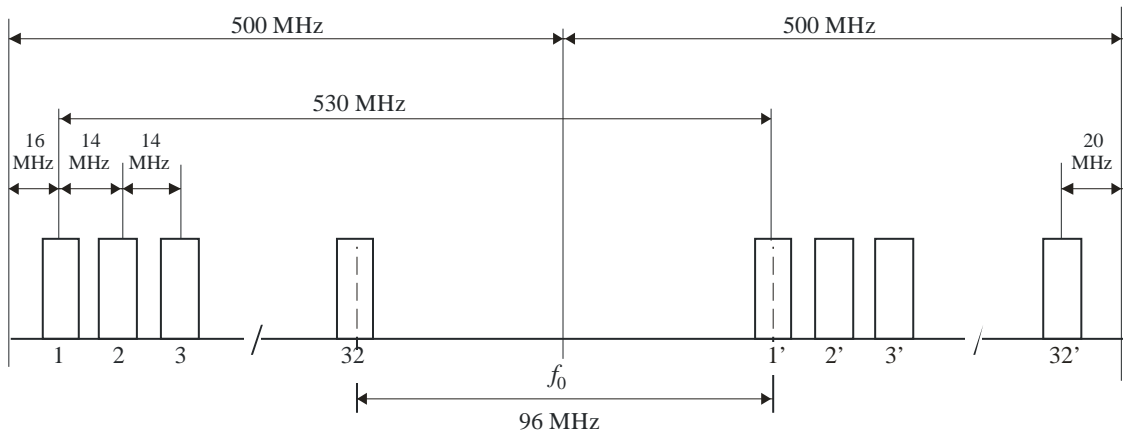

b) for systems with a carrier spacing of 14 MHz

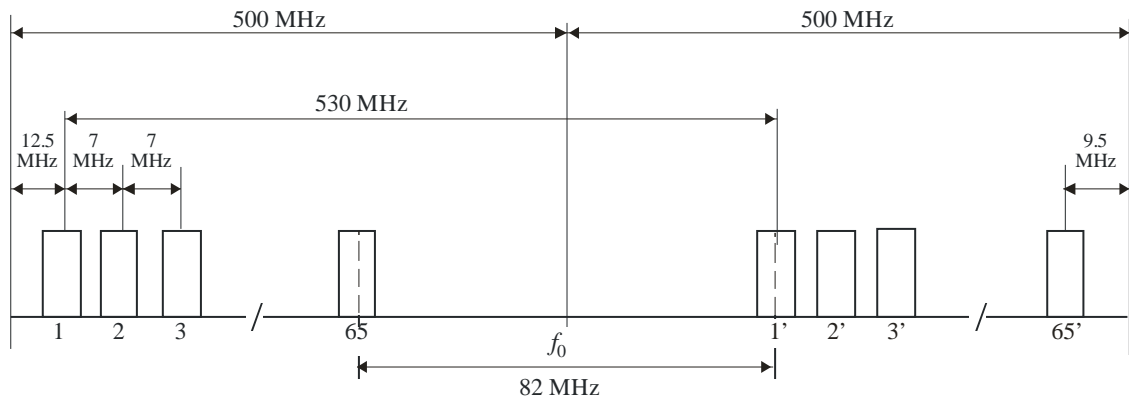

c) for systems with a carrier spacing of 7 MHz

