

RECOMMENDATION ITU-R F.385-7*

Radio-frequency channel arrangements for radio-relay systems operating in the 7 GHz band**

(Question ITU-R 136/9)

(1959-1963-1978-1982-1986-1990-1992-1994-2001)

The ITU Radiocommunication Assembly,

considering

- a) that it is desirable to be able to interconnect 60, 120 and 300-channel radio-relay systems on international circuits at radio frequencies in the 7 GHz band;
- b) that frequency bands 300 MHz wide may be available for such systems;
- c) that economy may be achieved if several go and return channels are connected to one common transmit-receive antenna;
- d) that many interfering effects can be minimized by a carefully planned arrangement of the radio frequencies in radio-relay systems employing several radio-frequency (RF) channels;
- e) that, for reasons of frequency economy, it is desirable to interleave additional RF channels between those of the main pattern;
- f) that it is desirable that the values of the mid-frequencies of the RF channels be the same for 60, 120 and 300-channel systems;
- g) that the spacing between the mid-frequencies of the RF channels should be such that the systems can work with the maximum frequency deviation given in Recommendation ITU-R F.404 for such systems;
- h) that digital radio-relay systems at data rates up to 155 Mbit/s, including synchronous digital hierarchy bit rates, may operate in the 7 GHz RF band,

recommends

1 that the preferred RF channel arrangement for several radio-relay systems, each accommodating 60, 120 or 300 telephone channels and operating in the 7 GHz band, should be derived as follows (see Fig. 1):

Let f_0 be the frequency of the centre of the band of frequencies occupied (MHz),
 f_n be the centre frequency of one RF channel in the lower half of this band (MHz),
 f'_n be the centre frequency of one RF channel in the upper half of this band (MHz),

* This Recommendation applies only to line-of-sight and near line-of-sight radio-relay systems.

** Subject to agreement between the administrations concerned, higher-capacity systems using the RF channel arrangement pattern defined in this Recommendation may be accepted if necessary.

then the frequencies (MHz) of the individual channels are expressed by the following relationships:

$$\text{lower half of the band: } f_n = f_0 - 154 + 7n \text{ (see Note 1)}$$

$$\text{upper half of the band: } f'_n = f_0 + 7 + 7n \text{ (see Note 1)}$$

where:

$$n = 1, 2, 3, \dots, 20;$$

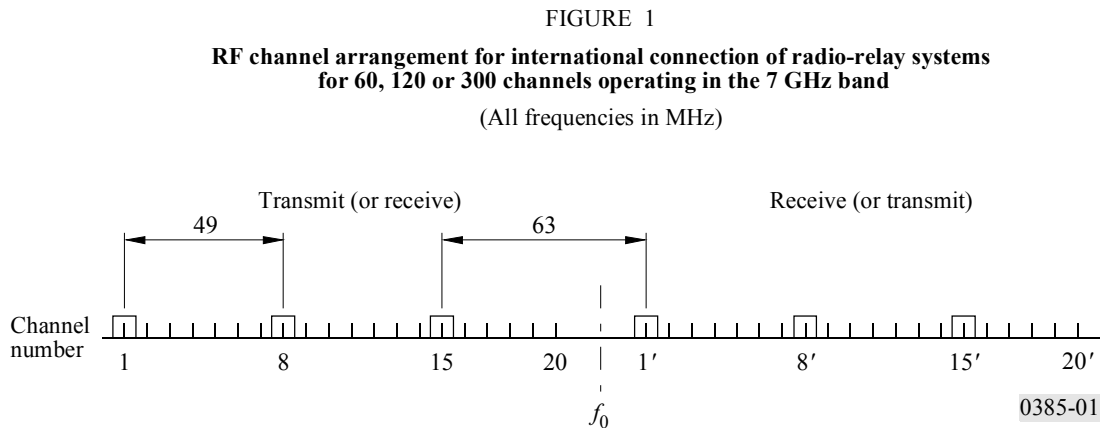

2 that, in a section over which the international connection is arranged, all the go channels should be in one half of the band and all the return channels should be in the other half of the band;

3 that, when common transmit-receive antennas are used and three RF channels are accommodated on a single antenna, it is preferable that the channel frequencies be selected by making:

$$n = 1, 8 \text{ and } 15, \text{ or}$$

$$n = 2, 9 \text{ and } 16, \text{ or}$$

$$n = 3, 10 \text{ and } 17, \text{ or}$$

$$n = 4, 11 \text{ and } 18, \text{ or}$$

$$n = 5, 12 \text{ and } 19, \text{ or}$$

$$n = 6, 13 \text{ and } 20,$$

in both halves of the band;

4 that for international connections, the centre frequency should preferably be:

$$f_0 = 7575 \text{ MHz for the band } 7425 \text{ to } 7725 \text{ MHz (see Note 1);}$$

other centre frequencies may be used in certain geographical areas by agreement between the administrations concerned, e.g.:

$$f_0 = 7275, 7400 \text{ or } 7700 \text{ MHz (see Note 1);}$$

5 that the channel arrangement and antenna polarization should be agreed between the administrations concerned;

6 that, when systems with 300 telephone channels are operated in a RF band, channel combinations which result in differences between channel frequencies of less than 14 MHz, should in general be avoided. If sufficient antenna discrimination is available, this precaution may be disregarded;

7 that the RF channel arrangement in use by some administrations, and described in Annexes 1, 2, 3, 4 and 5, may be used for digital systems.

NOTE 1 – The formulae for f_n and f'_n and the values for f_0 differ from those given in a former version of Recommendation 284 (Los Angeles, 1959). This change has been made so that the “centre frequency” f_0 falls, in reality, in the centre of the band of frequencies occupied.

ANNEX 1

RF channel arrangement in the band 7 425-7 725 MHz with a channel spacing of 28 MHz

1 This Annex describes a RF channel arrangement for digital radio-relay systems of 34 Mbit/s capacity and for coexistence of digital systems and analogue radio-relay systems up to 300 channels, operating in the band 7 425-7 725 MHz. The RF channel arrangement is shown in Fig. 2 and is derived as follows:

Let f_0 be the frequency of the centre of the band of frequencies occupied (MHz),
 f_n be the centre frequency of one RF channel in the lower half of the band (MHz),
 f'_n be the centre frequency of one RF channel in the upper half of the band (MHz),

then the frequencies (MHz) of the individual channels are expressed by the following relationships:

lower half of the band: $f_n = f_0 - 161 + 28 n$

upper half of the band: $f'_n = f_0 - 7 + 28 n$

where:

$n = 1, 2, 3, 4$ and 5 .

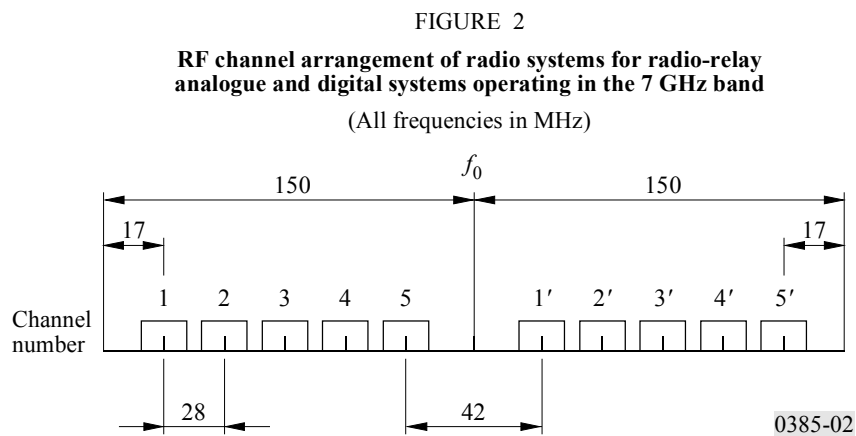

2 All go channels should be in one half of the band and all return channels should be in the other half of the band.

3 For adjacent RF channels in the same half of the band, different polarizations may be used for alternate channels or where it is possible, both polarizations may be utilized for each digital radio-frequency channel.

4 When additional analogue radio frequencies are required, they should be interleaved between those of the main pattern of Fig. 2, and can be realized by the same f_0 and the following relationship:

$$\text{lower half of the band: } f_n = f_0 - 175 + 28 n$$

$$\text{upper half of the band: } f'_n = f_0 + 7 + 28 n$$

where:

$$n = 1, 2, 3, 4 \text{ and } 5.$$

5 When additional digital radio frequencies interleaved between those of the main pattern of Fig. 2 are required, they can be realized by the same f_0 and the following relationship:

$$\text{lower half of the band: } f_n = f_0 - 147 + 28 n$$

$$\text{upper half of the band: } f'_n = f_0 + 7 + 28 n$$

where:

$$n = 1, 2, 3 \text{ and } 4.$$

6 The preferred centre frequency f_0 is 7 575 MHz.

7 The local oscillators for the lower half of the band should preferably be 70 MHz above the respective channel frequency and for the upper half of the band 70 MHz below the channel frequency. This will ensure that the image frequencies will fall within the band. However, the application of certain techniques, particularly the use of image frequency rejection mixers, helps to overcome this constraint.

ANNEX 2

RF channel arrangement in the band 7 435-7 750 MHz with channel spacings of 5, 10 or 20 MHz

1 This Annex describes a RF channel arrangement suitable for digital radio-relay systems up to 19 Mbit/s (1.544×12) and allows coexistence of digital systems and medium capacity analogue systems spaced on a 20 MHz interval operating in the band 7 435-7 750 MHz. Coexistence can also be achieved with analogue 960 telephone channels. The RF channel arrangement is shown in Fig. 3 and is derived as follows:

Let f_0 be the frequency of the centre of the band of frequencies occupied (MHz),

f_n be the centre frequency of one RF channel in the lower half of the band (MHz),

f'_n be the centre frequency of one RF channel in the upper half of the band (MHz),

then the frequencies (MHz) of the individual channels are expressed by the following relationships:

lower half of the band: $f_n = f_0 - 152.5 + 5 n$

upper half of the band: $f'_n = f_0 + 7.5 + 5 n$

where:

$n = 1, 2, 3, 4, 5, 6, \dots, 28.$

FIGURE 3
RF channel arrangement for digital systems operating in the 7 GHz band
 (All frequencies in MHz)

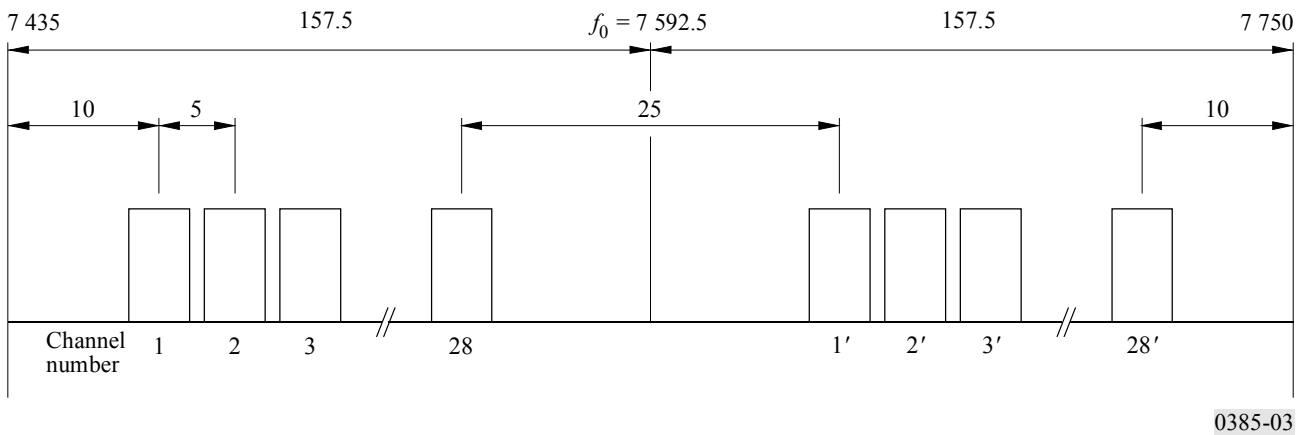

2 All go channels should be in one half of the band and all return channels should be in the other half of the band.

3 The centre frequency f_0 is 7 592.5 MHz.

4 For all RF channels in the same half of the band, the same polarization may be used or, where it is necessary because of the existence of interference, different polarizations may be utilized.

Where it is possible, both polarizations may be utilized for each digital RF channel.

5 Digital RF channels for 12.6 Mbit/s (1.544×8) or 19 Mbit/s (1.544×12) systems, can be realized by use of a 10 MHz or 20 MHz interval.

ANNEX 3

RF channel arrangement in the band 7 110-7 750 MHz with a channel spacing of 28 MHz

This Annex describes a RF channel arrangement for the 7 GHz band. In the higher part of the band the original frequency pattern of the former version of Recommendation 284 (Los Angeles, 1959) has been maintained (see Note 1), in order to have a regular frequency pattern for the whole band.

The arrangement provides for up to ten go and ten return channels, each accommodating about 140 Mbit/s subdivided in two groups of five go and five return channels relating to the lower part and the higher part of the band.

The RF channel arrangement is as shown in Fig. 4 and is derived as follows:

Let f_{0l} be the frequency at the centre of the lower part of the band:

$$f_{0l} = 7275 \text{ MHz}$$

f_{0h} be the frequency at the centre of the higher part of the band:

$$f_{0h} = 7597 \text{ MHz}$$

f_{nl} is the centre frequency of one RF channel in the lower half of the lower part of the band

f'_{nl} is the centre frequency of one RF channel in the upper half of the lower part of the band

f_{nh} is the centre frequency of one RF channel in the lower half of the higher part of the band

f'_{nh} is the centre frequency of one RF channel in the upper half of the higher part of the band,

then the frequencies (MHz) of the individual channels are expressed by the following relationships:

$$f_{nl} = f_{0l} - 182 + 28 n$$

$$f'_{nl} = f_{0l} + 14 + 28 n$$

$$f_{nh} = f_{0h} - 168 + 28 n$$

$$f'_{nh} = f_{0h} + 28 n$$

where:

$$n = 1, 2, 3, 4, 5.$$

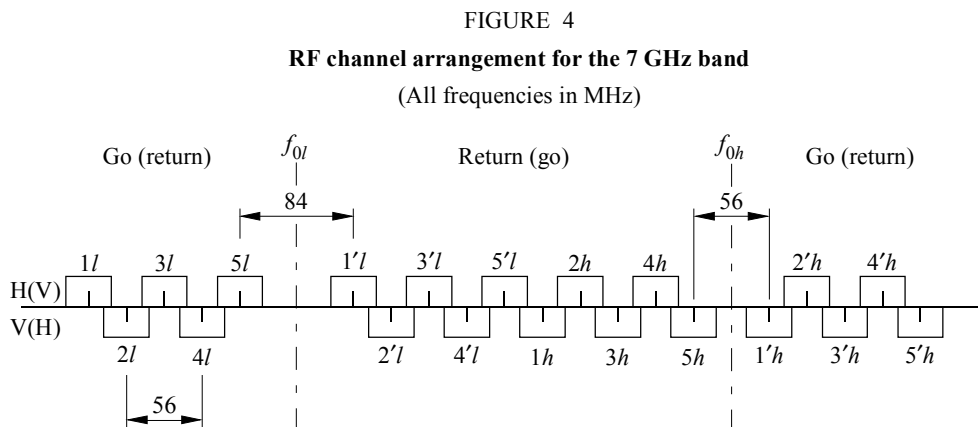

ANNEX 4

**RF channel arrangement in the band 7 425-7 900 MHz
with a channel spacing up to 28 MHz**

1 This Annex describes a RF channel arrangement suitable for digital radio-relay systems with a channel bandwidth up to 28 MHz, and makes provision for eight 28 MHz channels.

The radio-frequency channel arrangement is shown in Fig. 5 and is derived as follows:

Let f_0 be the frequency of the centre of the band of frequencies occupied (MHz),
 f_n be the centre frequency of one RF channel in the lower half of the band (MHz),
 f'_n be the centre frequency of one RF channel in the upper half of the band (MHz),

then the frequencies (MHz) of individual 28 MHz channels are expressed by the following relationships:

$$f_n = f_0 - 248.5 + 28 n$$

$$f'_n = f_0 - 3.5 + 28 n$$

where:

$$n = 1 \text{ to } 8.$$

FIGURE 5
RF channel arrangement for digital systems operating in the band 7 425-7 900 MHz
 (All frequencies in MHz)

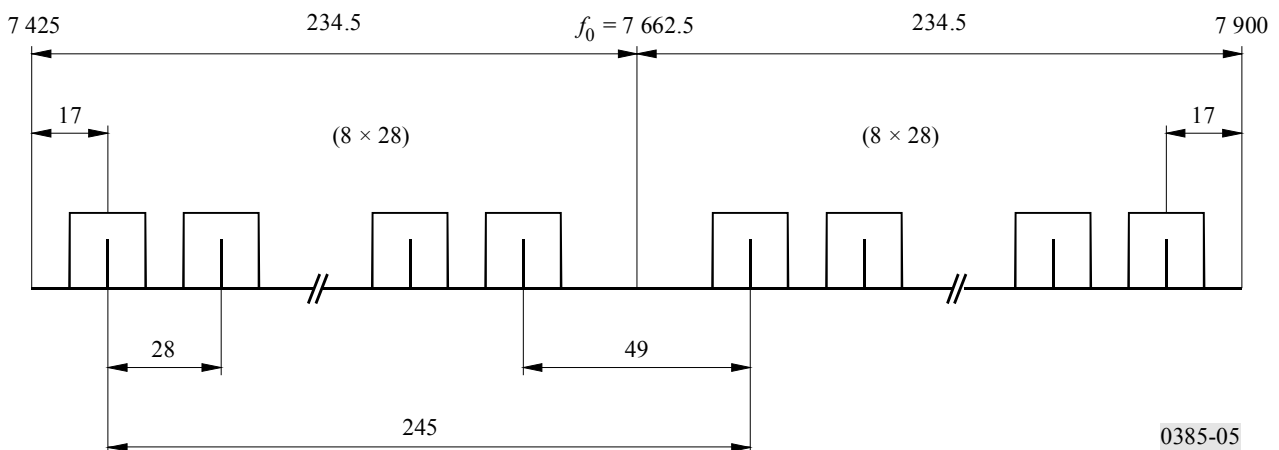

2 The eight channels with a spacing of 28 MHz can be subdivided to provide sixteen channels with a spacing of 14 MHz or thirty-two channels with a spacing of 7 MHz. The 28 MHz and 14 MHz channels are centred on the 7 MHz pattern of *recommends* 1 and 4, whilst the 7 MHz channels are interleaved with an offset of 3.5 MHz.

The frequencies (MHz) of individual channels are expressed by the following relationships:

for 14 MHz channels:

$$f_n = f_0 - 241.5 + 14 n$$

$$f'_n = f_0 + 3.5 + 14 n$$

where:

$$n = 1 \text{ to } 16$$

for 7 MHz channels:

$$f_n = f_0 - 238 + 7 n$$

$$f'_n = f_0 + 7 + 7 n$$

where:

$$n = 1 \text{ to } 32.$$

3 All go channels should be in one half of the band and all return channels should be in the other half of the band.

4 The centre frequency f_0 is 7 662.5 MHz.

NOTE 1 – The first five channels with a spacing of 28 MHz in the lower sub-band of the above channel arrangement align with those in Annex 1, covering the 7 425-7 725 MHz band. The go-return spacing is greater as a result of using the full 7 425-7 900 MHz band.

ANNEX 5

RF channel arrangement for radio-relay systems operating in the 7 250-7 550 MHz band with a channel spacing of 3.5 MHz

This Annex describes a RF channel arrangement suitable for digital radio-relay systems with a channel bandwidth of 3.5 MHz, and makes provision for thirty-nine 3.5 MHz channels.

The RF channel arrangement is shown in Fig. 6 and is derived as follows:

Let f_0 be the frequency of the centre of the band of frequencies occupied (MHz),

f_n be the centre frequency of one RF channel in the lower half of the band (MHz),

f'_n be the centre frequency of one RF channel in the upper half of the band (MHz),

then the frequencies (MHz) of individual 3.5 MHz channels are expressed by the following relationships:

$$f_n = f_0 - 150.5 + 3.5 n$$

$$f'_n = f_0 + 10.5 + 3.5 n$$

where:

$$n = 1 \text{ to } 39$$

$$f_0 = 7400 \text{ MHz}$$

FIGURE 6

RF channel arrangement for radio-relay systems operating in the 7 GHz band with a channel spacing of 3.5 MHz

(All frequencies in MHz)

