

RECOMMENDATION ITU-R F.1703-0¹**Availability objectives for real digital fixed wireless links
used in 27 500 km hypothetical reference paths and connections**

(2005)

Scope

This Recommendation provides updated information on availability objectives for real digital fixed wireless links used in 27 500 km hypothetical reference paths taking into account ITU-T Recommendation G.827 (approved in 2003). It is the only Recommendation defining availability objectives for all real digital fixed wireless links. Recommendations ITU-R F.1492 and ITU-R F.1493 are superseded by this Recommendation. The applicability of Recommendations ITU-R F.557, ITU-R F.695, ITU-R F.696 and ITU-R F.697 is limited to systems designed prior to the approval of this Recommendation. Examples of the application of the Recommendation are given in Annex 1. Definition of the events, derived from ITU-T Recommendation G.827, is given in Annex 2.

The ITU Radiocommunication Assembly,

considering

- a) that ITU-R has specified the error performance objectives for real digital fixed wireless links used in 27 500 km hypothetical reference paths (HRPs) and connections (see Recommendation ITU-R F.1668);
- b) that ITU-T has specified the availability parameters and objectives for end-to-end and path element of international constant bit-rate digital paths at or above the primary rate (see ITU-T Recommendation G.827);
- c) that digital fixed wireless systems play an important role in the international path;
- d) that it is necessary for the availability of fixed wireless systems to be compliant with the availability objectives specified in ITU-T Recommendation G.827;
- e) that any real path, link or connection for digital data transmission may be realized using a linear and/or redundant topology, depending on the needs of network providers;
- f) that digital fixed wireless systems may be used in intermediate and terminating countries of an international path;
- g) that for the purposes of this Recommendation, the national portion of the 27 500 km HRP can be subdivided into three basic sections (see Fig. 1);

¹ Radiocommunication Study Group 5 made editorial amendments to this Recommendation in November 2014 in accordance with Resolution ITU-R 1.

FIGURE 1
Basic sections of the national portion of the HRP

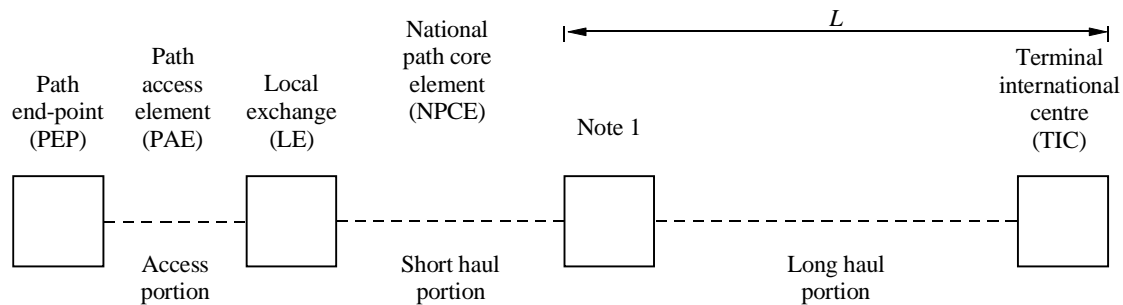

Note 1 – Depending on the country network architecture, this centre may coincide with a primary centre (PC), secondary centre (SC) or tertiary centre (TC) (see ITU-T Recommendation G.801).

Access: Access network section, including the connections between PEP and the corresponding local access switching centre/cross connector LE. It corresponds to the PAE.

Short haul: Short haul network portion, including the connections between a local access switching centre/cross connector, LE, and a PC, SC or TC (depending on the network architecture).

Long haul: Long haul network portion, including the connections between a PC, SC or TIC (depending on the network architecture) and the corresponding international gateway (IG).

Note 2 – TIC, PAE and NPCE are defined in ITU-T Recommendation M.1010.

1703-01

- h) that for the path elements of a constant bit-rate digital path at or above the primary rate, ITU-T Recommendation G.827 specifies fixed-block allocation plus distance-based allocations for the availability objectives;
- j) that there is a need to establish the availability objectives for real digital radio links in order to allow the proper engineering of fixed wireless links;
- k) that unavailability of fixed wireless systems may be due to propagation effects, equipment failure, human intervention, interference or other causes;
- l) that the availability objectives, availability ratio (AR) and mean time between outage (Mo) or its reciprocal, outage intensity (OI) are needed for design purposes,

recommends

- 1 that availability objectives applicable to any real digital fixed wireless link forming part of the international portion or belonging to the long-haul network portion of the national portion of an international constant bit-rate digital path and connection should be fixed-block plus distance-based allocated;
- 2 that availability objectives applicable to any real digital radio link belonging to the access and short-haul network portions of the national portion of an international constant bit-rate digital path and connection should be fixed block-based (i.e. length independent);

3 that the availability objectives applicable to each direction of a fixed wireless link of length, L_{link} , can be derived from the values given in Tables 1, 2, 3 and 4 by means of equations (1) and (2) for the AR and Mo, or the reciprocal of Mo defined as OI objectives, respectively;

$$AR = 1 - \left(B_j \frac{L_{link}}{L_R} + C_j \right) \quad (1)$$

$$Mo = 1/OI = \frac{1}{D_j \frac{L_{link}}{L_R} + E_j} \quad (2)$$

where:

the value of j is: for international portion:

- | | |
|---|---|
| 1 | for $L_{min} < L_{link} \leq 250$ km |
| 2 | for $250 \text{ km} < L_{link} \leq 2\,500$ km |
| 3 | for $2\,500 \text{ km} < L_{link} \leq 7\,500$ km |
| 4 | for $L_{link} > 7\,500$ km |

for section of national portion:

- | | |
|---|--------------------|
| 5 | for access network |
| 6 | for short haul |
| 7 | for long haul |

L_R : reference length $L_R = 2\,500$ km.

The lower limit of L_{link} used to scale the objectives is $L_{min} = 50$ km.

The values of B_j , C_j , D_j and E_j are given in Tables 1, 2, 3 and 4. The parameter OI refers to the number of unavailability events per year, so its reciprocal Mo has to be multiplied by the number of seconds in a year to represent the effective mean time between the unavailability events that have occurred in a year expressed in seconds;

4 that availability objectives should be partitioned in order to take into account unavailability events due to propagation events, equipment failure, human intervention and other causes. The partitioning of objectives for the different unavailability causes is outside the scope of this Recommendation;

5 that for the case when the link is composed of more than one hop, the objectives are applicable for the whole link. The scaling of the objectives for each individual hop is under the network operator responsibility (see Annex 1 for more information);

6 that the objectives for radio link forming part of any path element composing the international portion (i.e. inter-country path core element (ICPCE) and international path core element (IPCE)) should in any case not exceed the objectives defined in ITU-T Recommendation G.827 (see Annex 1 to this Recommendation for more information);

7 that the overall objectives for the national portion (i.e. obtained by adding the objectives of access network, short haul and long haul) implemented by fixed wireless systems should not exceed in any case the objectives defined in ITU-T Recommendation G.827 for the national portion element (see Note 5).

NOTE 1 – The international portion of a constant bit-rate digital path at or above the primary rate is composed of at least one ICPCE and/or one IPCE.

NOTE 2 – ICPCE is the path element (PE) carried on the highest order digital path across the border between two countries. The ICPCE is the link between networks in different countries, considered as subnetworks. This PE is limited by the frontier stations (FSs) where the highest order inter-country path may be terminated. When the highest order inter-country path is not terminated in the FS, the ICPCE is limited by the supporting inter-country section access point.

NOTE 3 – IPCE is the PE used in a core network. The boundary of this PE depends on its application; for a transit country this PE is limited by the two FSs. For a terminating country, this element is limited by the IG and the FS. In particular this element should be delimited by the international switching centre (ISC) and the FS or by the TIC, which corresponds to the end of the international portion, and the FS.

NOTE 4 – The international portion of a path is composed by the ICPE and ICPCE, so the boundary of this element corresponds to the IPCE (i.e. FS or TIC or ISC) and by the portion of ICPCE that crosses the border between two countries.

NOTE 5 – The national path element (NPE) is a PE used in a terminating country to connect the international portion and the PEP. The NPE includes both the PAE and the NPCE.

NOTE 6 – For the scope of this Recommendation the national portion corresponds to the NPE.

NOTE 7 – The TIC, the PAE and NPCE are defined in ITU-T Recommendation M.1010. (Note that the ISC and TIC may be in the same location.)

NOTE 8 – The criteria for entry to and exit from the unavailable state is defined in Annex A of ITU-T Recommendation G.826.

NOTE 9 – The objectives for access portion of the network are assumed length independent, since typically these links are shorter than 50 km.

NOTE 10 – The objectives for access portion and short-haul portion are defined for a maximum length $L_{max} = 250$ km.

NOTE 11 – The short-haul objectives for lengths greater than 2 500 km are not applicable.

NOTE 12 – The availability objectives and apportionment criteria for connections should be the same as for paths.

NOTE 13 – The criteria defining the entry to and exit from the unavailable state is defined in § A.1 of Annex A of ITU-T Recommendation G.826.

NOTE 14 – Further studies are invited to define what number of events, due to anomalous propagation conditions, can give rise to self-healing unavailability events, due to such events, usually much shorter than four hours mean time to restoration (MTTR) = four hours is defined in ITU-T Recommendation G.827 as a base for OI objectives), are not taken into account for OI objectives in ITU-T Recommendation G.827.

NOTE 15 – Further studies are invited to establish whether and to what extent the AR and the OI objectives can be improved.

TABLE 1

Parameters for AR objectives for links forming part of an international portion of constant bit-rate digital path

Length (km)	$L_{min} \leq L_{link} \leq 250$		$250 < L_{link} \leq 2\,500$		$2\,500 < L_{link} \leq 7\,500$		$L_{link} \geq 7\,500$	
	B_1	C_1	B_2	C_2	B_3	C_3	B_4	C_4
International portion	1.9×10^{-3}	1.1×10^{-4}	3×10^{-3}	0	3×10^{-3}	0	3×10^{-3}	0

TABLE 2

Parameters for AR objectives for links forming part of a national portion of constant bit-rate digital path element

Access portion		Short-haul portion		Long-haul portion			
B_5	C_5	B_6	C_6	B_7		C_7	
0	5×10^{-4}	0	4×10^{-4}	3×10^{-3} for $250 \text{ km} \leq L_{link} < 2\,500 \text{ km}$ 1.9×10^{-3} for $L_{min} \leq L_{link} < 250 \text{ km}$		0 for $250 \text{ km} \leq L_{link} < 2\,500 \text{ km}$ 1.1×10^{-4} for $L_{min} \leq L_{link} < 250 \text{ km}$	

TABLE 3

Parameters for OI objectives for links forming part of an international portion of constant bit-rate digital path

Length (km)	$L_{min} \leq L_{link} \leq 250$		$250 < L_{link} \leq 2\,500$		$2\,500 < L_{link} \leq 7\,500$		$L_{link} \geq 7\,500$	
	D_1	E_1	D_2	E_2	D_3	E_3	D_4	E_4
International portion	150	50	100	55	100	55	100	55

TABLE 4

Parameters for OI objectives for links forming part of a national portion of constant bit-rate digital path element

Access portion		Short-haul portion		Long-haul portion			
D_5	E_5	D_6	E_6	D_7		E_7	
0	100	0	120	100 for $250 \text{ km} \leq L_{link} < 2\,500 \text{ km}$ 150 for $L_{min} \leq L_{link} < 250 \text{ km}$		55 for $250 \text{ km} \leq L_{link} < 2\,500 \text{ km}$ 50 for $L_{min} \leq L_{link} < 250 \text{ km}$	

Annex 1

Terminology and examples of evaluation for real link

1 Introduction

This Annex gives further information on the meaning of terms related to the connection, on the relationship between the objectives given by ITU-T Recommendation G.827 and the objectives defined in this Recommendation and some examples of the evaluation of the objectives for a real radio link.

2 Definition and terminology

The scope of this Recommendation is to define the availability objectives for a real radio link, but since in a telecommunication network the term “link” is quite general the clarification of the meaning of this term within the context of the current Recommendation is given below.

The definition of PE is given in ITU-T Recommendation G.827. An example of a path composed by several PEs is shown in Fig. 2. A radio link can be identified with a portion of the path and it can implement an IPCE (or a portion of it) and/or an ICPCE, as shown in Fig. 3, or can belong to any portion of the network, as shown in Fig. 4. Moreover a link can be formed by several hops.

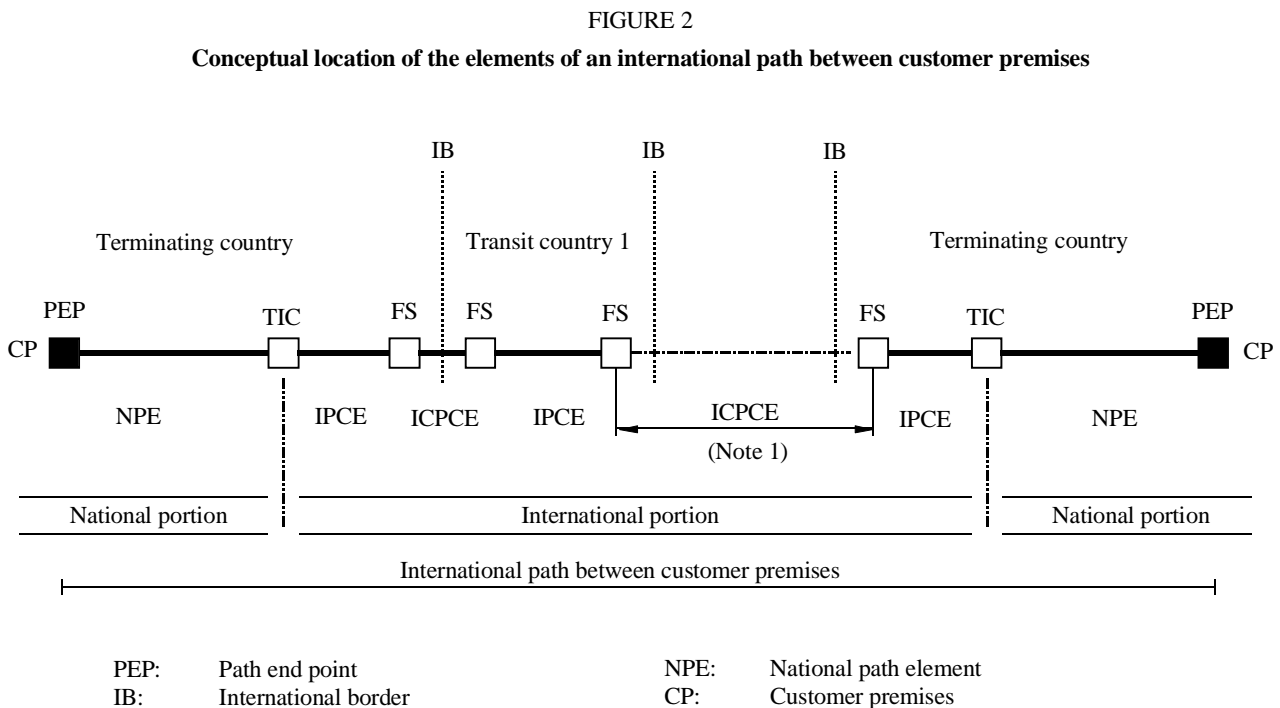

Note 1 – This ICPCE crosses two international borders and is typically supported by a satellite or undersea transmission system.

FIGURE 3
Example of a radio link implementing a portion of IPCE

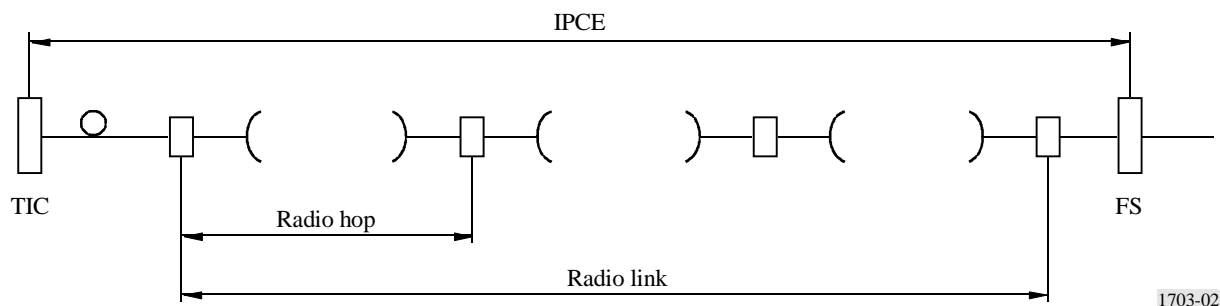
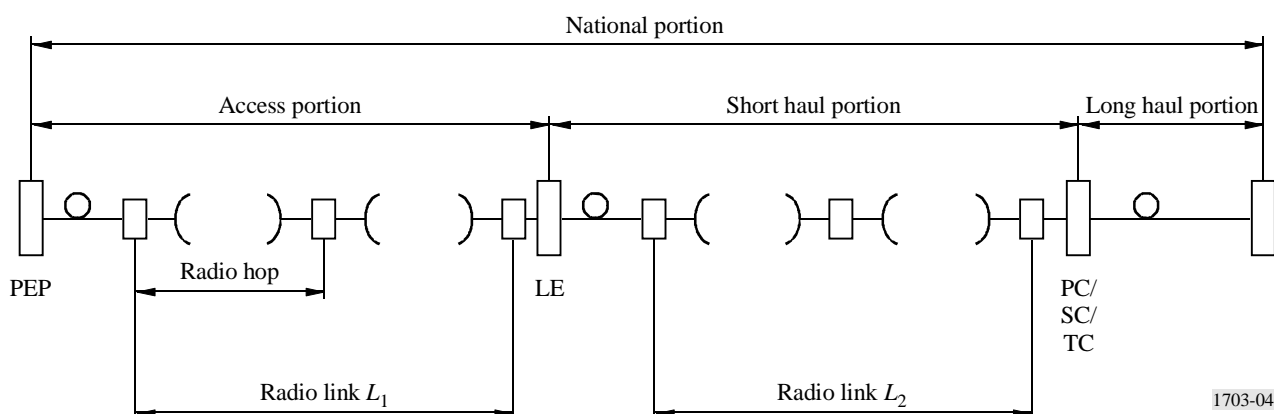

FIGURE 4
Example of radio links used in access portion and short haul portion of NPE



Historically the terminology used in ITU-T Recommendation G.827 is derived from maintenance requirements for international paths, since availability is one of the main factors influencing the behaviour of radio path. In fact, in the past, error performance requirements were a negligible factor, so they were not considered. Nowadays, from the point of view of maintenance, error performance has the same importance as availability. Furthermore, performance and availability requirements are the fundamental requisites for the design of links.

Moreover, the error performance objectives defined in Recommendations ITU-R F.1668 and in ITU-T Recommendations G.826, G.828 and G.829 for plesiochronous digital hierarchy (PDH), synchronous digital hierarchy (SDH) and cell-based paths, are based on different elements of a path. In particular the elements composing an SDH are the multiplex section (MS) and the regenerator section (RS), which are the basis for performance definitions. In order to clarify the relationship between error performance and availability objectives, the relationship between the SDH sections and PEs should be explained.

Figures 5 and 6 show examples of a radio link implementing a portion of an IPCE and a part of a short-haul portion NPE and composed of SDH MS and RS. The objectives of this Recommendation are applicable to the radio link, while the objectives of Recommendation ITU-R F.1668 are

applicable to the single SDH MS and RS implemented by radio. The subdivision of availability and performance objectives to each hop is outside the scope of this Recommendation and of Recommendation ITU-R F.1668.

FIGURE 5
Example of a radio link implementing a portion of the IPCE

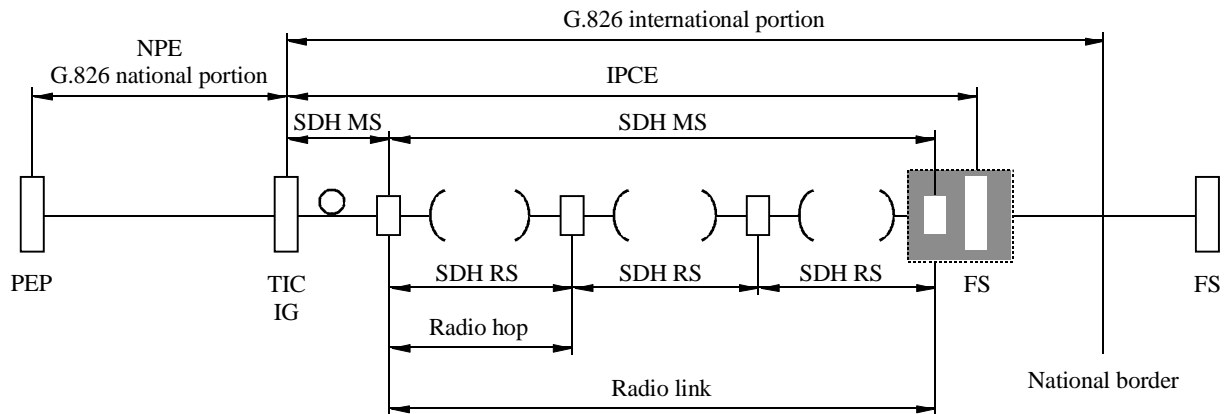

1703-05

FIGURE 6
Example of a radio link implementing a portion of the NPE

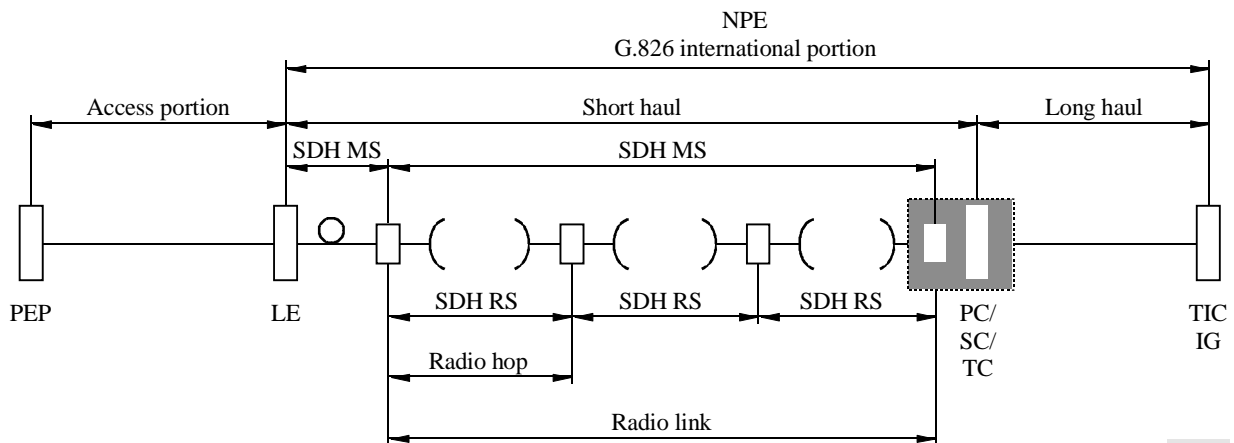

1703-06

For the design of a radio link, besides the objectives, propagation effects should be considered carefully, since the relation between availability and performance is defined by propagation phenomena. In fact generally speaking a propagation phenomena may have a greater influence on performance, but lesser on availability, or vice versa.

The availability objective of a radio link as defined in this Recommendation should be compliant with the NPE objectives defined by ITU-T Recommendation G.827.

3 Calculation of availability objectives

This section shows some examples of the application of this Recommendation to real links, in order to derive the objectives.

In the following calculations, it is assumed that one year corresponds to 525 960 min.

3.1 International portion

Case 1: length 30 km

The length is shorter than $L_{min} = 50$ km, so the value of $L_{link} = 50$ has been used.

$$AR = 1 - \left(B_1 \frac{L_{link}}{L_R} + C_1 \right) = 1 - \left(1.9 \times 10^{-3} \frac{50}{2500} + 1.1 \times 10^{-4} \right) = 0.99985$$

$$Mo = \frac{1}{D_1 \frac{L_{link}}{L_R} + E_1} = \frac{1}{150 \frac{50}{2500} + 50} = \frac{1}{53} = 18.87 \times 10^{-3}$$

These values correspond to an AR of 99.985% (unavailability of 78 min/year), number of events per year of OI = 53 and the mean time between unavailability events $Mo = 9\,922$ min or 6.9 days.

Case 2: length 80 km

The length is in the range 50-250 km, so:

$$AR = 1 - \left(B_1 \frac{L_{link}}{L_R} + C_1 \right) = 1 - \left(1.9 \times 10^{-3} \frac{80}{2500} + 1.1 \times 10^{-4} \right) = 0.99983$$

$$Mo = \frac{1}{D_1 \frac{L_{link}}{L_R} + E_1} = \frac{1}{150 \frac{80}{2500} + 50} = \frac{1}{54.8} = 18.25 \times 10^{-3}$$

These values correspond to an AR of 99.983% (unavailability of 90 min/year), number of events per year of OI = 55 and the mean time between unavailability events $Mo = 9\,596$ min or 6.7 days.

Case 3: length 1056 km

The length is in the range 250 km-2 500 km, so:

$$AR = 1 - \left(B_1 \frac{L_{link}}{L_R} + C_1 \right) = 1 - \left(3 \times 10^{-3} \frac{1056}{2500} + 0 \right) = 1 - 1.27 \times 10^{-3} = 0.998732$$

$$Mo = \frac{1}{D_2 \frac{L_{link}}{L_R} + E_2} = \frac{1}{100 \frac{1056}{2500} + 55} = \frac{1}{97.24} = 10.28 \times 10^{-3}$$

The previous values correspond to an AR of 99.873% (unavailability of 667 min/year), number of events per year of OI = 97 and the mean time between unavailability events $Mo = 5\,402$ min or 3.7 days.

3.2 National portion

Case 1: length 30 km in access portion

The length is shorter than $L_{min} = 50$ km, so the value of $L_{link} = 50$ km has been used.

$$AR = 1 - \left(B_5 \frac{L_{link}}{L_R} + C_5 \right) = 1 - \left(0 \frac{50}{2500} + 5 \times 10^{-4} \right) = 0.9995$$

$$Mo = \frac{1}{D_5 \frac{L_{link}}{L_R} + E_5} = \frac{1}{0 \frac{50}{2500} + 100} = 1 \times 10^{-2}$$

These values correspond to an AR of 99.95% (unavailability of 263 min/year), number of events per year of OI = 100 and the mean time between unavailability events $Mo = 5\,257$ min.

Case 2: length 105 km in short-haul portion

The length is in the range 50-250 km, so:

$$AR = 1 - \left(B_6 \frac{L_{link}}{L_R} + C_6 \right) = 1 - \left(0 \frac{105}{2500} + 4 \times 10^{-4} \right) = 0.9996$$

$$Mo = \frac{1}{D_6 \frac{L_{link}}{L_R} + E_6} = \frac{1}{0 \frac{105}{2500} + 120} = 8.34 \times 10^{-3}$$

These values correspond to an AR of 99.96% (unavailability of 210 min/year), number of events per year of OI = 120 and the mean time between unavailability events $Mo = 4\,381$ min.

Case 3: length 960 km in long-haul portion

The length is in the range 250-2 500 km, so:

$$AR = 1 - \left(B_7 \frac{L_{link}}{L_R} + C_7 \right) = 1 - \left(3 \times 10^{-3} \times \frac{960}{2500} + 0 \right) = 0.9988$$

$$Mo = \frac{1}{D_7 \frac{L_{link}}{L_R} + E_7} = \frac{1}{100 \frac{960}{2500} + 55} = 1.071 \times 10^{-2}$$

These values correspond to an AR of 99.88% (unavailability of 606 min/year), number of events per year of OI = 93 and the mean time between unavailability events $Mo = 5\,627$ min.

Case 4: overall objectives for a link of 1 095 km length composed by 30 km in access portion, 105 km in short-haul portion and 960 km in long-haul portion

The AR objectives of this link are given by the sum of the unavailability objectives referred to the portion of the link belonging to each network portion:

$$AR = 1 - UR = 1 - (UR_{AN} + UR_{SH} + UR_{LH}) = 1 - (5 \times 10^{-4} + 4 \times 10^{-4} + 1.2 \times 10^{-3}) = 0.9979$$

where:

- UR : total unavailability ratio
- UR_{AN} : unavailability ratio objective of the access portion
- UR_{SH} : unavailability ratio objective for short-haul portion
- UR_{LH} : unavailability ratio objective for long-haul portion (see above reported examples).

The Mo objective is given by the reciprocal of the sum of OI objectives referred to the part of link belonging to each network portion:

$$Mo = \frac{1}{OI_{AN} + OI_{SH} + OI_{LH}} = \frac{1}{100 + 120 + 93} = 3.19 \times 10^{-3}$$

where:

- Mo : total mean time between outage
- OI_{AN} : outage intensity objective of the access portion
- OI_{SH} : outage intensity objective for short-haul portion
- OI_{LH} : outage intensity objective for long-haul portion (see above reported examples).

These values correspond to an AR of 99.79% (unavailability of 1 114 min/year), number of events per year $OI = 313$ and the mean time between unavailability events $Mo = 1 674$ min.

According to ITU-T Recommendation G.827 the objectives for a 1 095 km NPE are:

- AR standard = 0.9945
- AR high = 0.99912
- OI standard = 12
- OI high = 6.

In this example the AR objectives are compliant with ITU-T Recommendation G.827 for standard performance level.

OI objectives in ITU-T Recommendation G.827 are based on an MTTR value of four hours. It is recognized that some events, due to anomalous working conditions, such as propagation impairments for radio applications, can give rise to self-healing unavailability events, such events, usually much shorter, are not taken into account for OI objectives in ITU-T Recommendation G.827, but in any case, the overall AR objectives have not to be exceeded.

Annex 2

Parameter definition

1 Availability ratio (AR) and unavailability ratio (UR)

The term “availability” refers to the AR, which is the proportion of time that a path is in the available state during an observation period. AR is calculated by dividing the total available time during the observation period by the duration of the observation period.

The converse of AR, the UR, is the proportion of time that an end-to-end path is in the unavailable state during an observation period. UR is calculated by dividing the total unavailable time during the observation period by the duration of the observation period.

$$AR + UR = 1$$

The observation period is recommended to be one year.

The allocation of availability objectives to observation periods shorter than one year is outside the scope of this Recommendation.

Planned available time

If the connection is not planned to be a permanent connection, then the periods when the connection is not in service do not count in the calculation of its availability. This may impact on the choice of the observation period.

2 Mean time between outages and outage intensity

A period of unavailability is also known as an “outage”. The mean time between outages (Mo) is the average duration of intervals when the PE is available during a measurement period. The number of outages per measurement period is called the “outage intensity” (OI). (See Note 1.)

If the measurement period is one year and the Mo is expressed in fractions of a year, then the OI is the reciprocal of the Mo.

NOTE 1 – This relation assumes that the periods of unavailability are small compared to the periods of availability.
