

RECOMMENDATION ITU-R F.1490-1*

Generic requirements for fixed wireless access systems

(Questions ITU-R 125/9 and ITU-R 215/8)

(2000-2007)

Introduction

Today many technologies have been considered for fixed wireless access (FWA) applications, in particular, technologies from cellular platforms and specialized systems.

The application of FWA will benefit both developing and developed countries. Many countries are planning to deploy FWA systems for the primary delivery of telecommunication services. In this Recommendation, two different FWA platforms are considered – one based on a public mobile network and the other based on a PSTN network.

Scope

This Recommendation summarizes generic requirements needed to ensure that radio technologies can be applied to FWA applications and intended for the use by administrations and operators considering deployment of FWA systems.

Abbreviations

AMSC	Anchor mobile switching centre
BS	Base station
DTMF	Dual tone multi-frequency
FMC	Fixed mobile convergence
FS	Fixed station
LAN	Local area network
MAN	Metropolitan area networks
MPEG	Moving Picture Expert Group
MSC	Mobile services switching centre
PABX	Private automatic branch exchange
PCS	Personal communications systems
PSTN	Public switched telephone networks
P-MP	Point-to-multipoint
P-P	Point-to-point
RNC	Radio network controller
SDH	Synchronous digital hierarchy

* This Recommendation should be brought to the attention of Radiocommunication Study Group 8 (Working Party 8A).

SN	Service node
TDMA	Time division multiplexing access
TE	Terminal equipment

References

ITU-R Recommendations

Recommendation ITU-R F.757:	Basic system requirements and performance objectives for fixed wireless access using mobile-derived technologies offering basic telephony services.
Recommendation ITU-R M.819:	International Mobile Telecommunications-2000 (IMT-2000) for developing countries.
Recommendation ITU-R F.1400:	Performance and availability requirements and objectives for fixed wireless access to public switched telephone network.
Recommendation ITU-R F.1399:	Vocabulary of terms for wireless access.

ITU-T Recommendations

ITU-T Recommendation G.173:	Transmission planning aspects of the speech service in digital public land mobile networks.
ITU-T Recommendation G.174:	Transmission performance objectives for terrestrial digital wireless systems using portable terminals to access the PSTN.
ITU-T Recommendation G.175:	Transmission planning for private/public network interconnection of voice traffic.
ITU-T Recommendation G.711:	Pulse code modulation (PCM) of voice frequencies.
ITU-T Recommendation G.726:	40, 32, 24, 16 kbit/s adaptive differential pulse code modulation (ADPCM).
ITU-T Recommendation G.728:	Coding of speech at 16 kbit/s using low delay-code excited linear prediction.
ITU-T Recommendation I.430:	Basic user-network interface – Layer 1 specification.
ITU-T Recommendation G.965:	V-interfaces at the digital local exchange (LE) – V5.2 interface (based on 2048 kbit/s) for the support of access network (AN).

Recommendations

The ITU Radiocommunication Assembly recommends that the following requirements for FWA systems should be met.

1 Service requirements

Identified telephony-based requirements for FWA:

- FWA subscribers can have wireline (i.e. PSTN-like) numbers.
- FWA subscribers can have local area dialling capability (dial tone, etc.) similar to that of fixed PSTN subscribers.
- FWA subscribers' tariffing structure can be selected by the operator. Wireline-like (PSTN-like) tariffing scheme can be used if required.

- In order to achieve faster call set-up times, transparent mode is needed as an alternative option in FWA based on mobile network solution (see § 4).
- Fixed station (FS) terminal remote management (see § 5).
- Payphone support (see § 6).
- Group 3 facsimile support (see § 6).
- Charging capabilities (see § 6).
- Performance monitoring (see § 5).
- Power and lightning protection.
- Optional display for FWA terminal (in order to get use of supplementary services).
- Performance and availability objectives and requirements must meet those established in Recommendation ITU-R F.1400.

1.1 Applications of FWA

Likely applications or services for data rates higher than 64 kbit/s (based on report of survey responses for FWA), for those systems that are able to support these data rates:

- Internet access.
- Multimedia and interactive applications such as telemedicine and tele-education.
- Intranet.
- Videoconference.
- Videophone for banking, tourist agencies, etc.
- ISDN.
- File transfer.
- Leased lines.
- Banking.
- Tourist agencies.
- Remote host access.
- MPEG video.
- Ethernet.
- Wireless local area network (LAN).
- Broadband service delivery to homes and business.
- Wireless broadband for trunk configurations for mobile telecommunications systems (e.g. PCS and GSM) in backhaul links, metropolitan area networks (MANs), and synchronous digital hierarchy (SDH) rings.
- Private automatic branch exchange (PABX) (virtual, e.g. wireless Centrex).

1.2 Minimum bit rate for data services

Some requirements have indicated a minimum bit rate of 9.6 kbit/s. However, other requirements for data services will be equivalent to those for IMT-2000 in the mobile environment (144 kbit/s and above).

1.3 ISDN compatibility

Required in most cases (see Annexes 1 and 2 for more information).

2 FWA system capabilities

FWA applications could have the following capabilities:

- a) to rapidly deploy a fixed wireless technology to provide voice services in large segments of the market that do not have any telecommunication service;
- b) to meet a pent-up demand for high-end, broadband services, both in the business and residential markets;
- c) as a rural type, to achieve one of major goals in a country for the improvement of telephone density in rural areas;
- d) to provide the availability of desired added features besides local telephone service features for the customers;
- e) to provide the fixed wireless capabilities for service providers, for example; in order to deploy a wireless competitive local exchange carrier in competition with the incumbent local exchange carrier;
- f) to provide a second or third telephone for customers due to increased uses of fax machines, modems, and Internet access;
- g) to provide wireless Centrex and private branch exchange for business customers having a traffic requirement at the primary rate and above and searching for low cost alternatives;
- h) as an urban type, to provide as multimedia-compatible wireless access network in place of wired networks in the development of new commercial, industrial and residential areas on spot basis in urban area.

3 Types of FWA systems

FWA systems may be broadly categorized as three types, each addressing a different market:

- Wireline equivalent/replacement system applies where wireline services and equipment must be supported to the full extent: either due to the type of equipment to be supported or due to the expectations of the user. Capable of delivering toll quality speech and performance equivalent to wired access service.
- Fixed mobile convergence (FMC) system applies where the prime requirement is reduced cost and ease of installation, and the requirements for equipment support or customer service expectation are different than full wireline support.
- Broadband system applies where greater traffic throughput is required, such as business and interactive applications.

Because of these different target markets, FWA systems will have different service requirements. These three markets can be distinguished by some of their basic services as follows:

3.1 Wireline equivalent/replacement system

- a) Minimum capability to support fax and modem service with support for higher data rates desired.
- b) Optional support for ISDN.
- c) No mobility between the network and the subscriber premises network interface device.
- d) End user terminals may be mobile (e.g. cordless phone).

3.2 FMC system

- a) Capable of supporting wireline – like service.
- b) Capable of delivering performance equivalent to cellular voice quality.
- c) Capable of delivering fallback rate support for modem and fax service.
- d) Optional limited mobility support.
- e) Extension of existing cellular standards which may provide a higher level of wireline transparency.

3.3 Broadband system

- a) Capable of supporting greater speeds than wireline equivalent/replacement system.
- b) Fixed network and users supported.

4 FWA system configurations

Due to the different needs in different environments two separate FWA network level solutions are needed. Those two systems are named here as FWA supported from a mobile network and FWA supported from a PSTN access network. It is believed that both network level solutions are needed in order to satisfy the needs of different operators and end-users.

4.1 FWA supported from a mobile network

The FWA supported from a mobile network could be based on the standard mobile network and mobile services switching centre (MSC). This solution basically comprises of the following network elements: MSC, radio network controller (RNC), base station (BS), fixed cellular subscriber units, known as FWA terminals and terminal equipment (TE). In this application handover between cells is not supported. From the system point of view, interfaces to the end-user terminals (e.g. telephone, facsimile machine, personal computer, etc.) and network management system are included. In this system solution, the MSC operates as a service node (SN). Figure 1 shows a reference model for this solution.

As can be seen from Fig. 1, the FWA system includes a possibility to provide services to both fixed and mobile users. This is an important requirement as already pointed out in Recommendation ITU-R M.819.

FIGURE 1
A reference model of the FWA supported from a mobile network

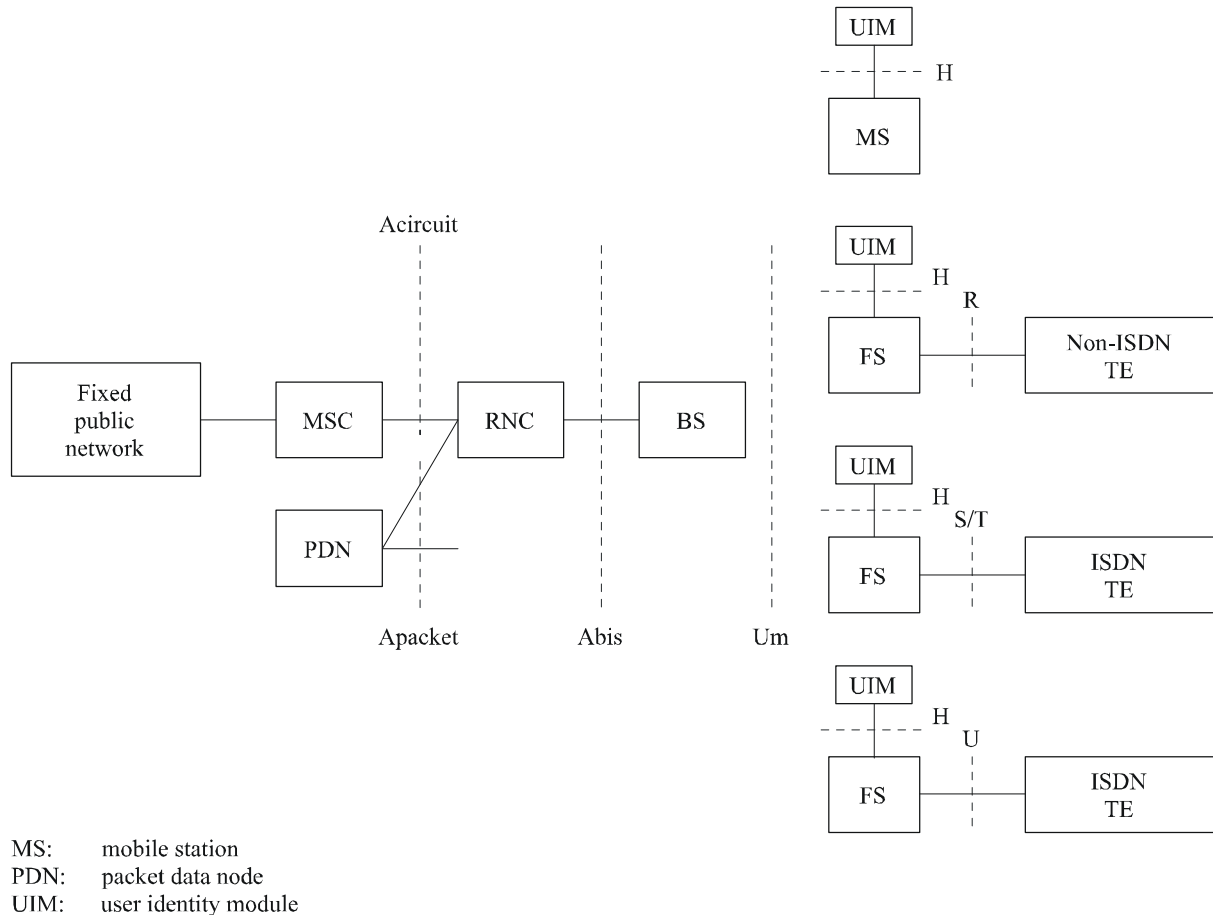

Reference points in Fig. 1

Abis: reference point between the RNC and the BS

Acircuit: reference point for circuit switched traffic between the RNC and the MSC

Apacket: reference point for packet data traffic between the RNC and the PDN

H: reference point between the MS and the UIM

R: non-ISDN terminal reference point. 2-wire interface is one example of such interface

S/T: standard ISDN reference point. For example ITU-T Recommendation I.430 or according to some other ISDN interface

U: standard ISDN reference point

Um: reference point between the FS (or MS) and the BS

Open standard interfaces are used in both network interface and the customer interfaces. This enables, on one hand, switch vendors easily to build independent switching and radio networks and on the other hand, end-users to use standard equipment like telephone sets, fax machines, personal computers etc.

This solution meets, especially, the needs of mobile operators seeking for FWA subscribers and also to greenfield operators who start their operations with FWA and later seek to enhance their service offerings to mobile users.

The following additions may need to be made to an ordinary mobile system in order to create FWA supported from a mobile network. These additions are:

- FWA subscribers should have wireline (i.e. PSTN-like) numbers.
- FWA subscribers should have local area dialling capability (dial tone, etc.) similar to that of a fixed PSTN subscriber.
- FWA subscribers typically have some form of mobility restriction. The operator can define the mobility (service area) for each subscriber individually. These subscribers can then only get telephone service inside his/her FWA service area.
- FWA subscribers' tariffing structure can be selected by the operator. Wireline-like (PSTN-like) tariffing scheme can be used if required.
- In order to achieve faster call set-up times, transparent mode may be needed as an alternative option in FWA based on mobile system solution.
- FS terminal remote management.

4.2 FWA supported from a PSTN access network

The FWA supported from a PSTN access network comprises of the FWA access node, the standard BS, FWA stations and standard TE. From the system point of view, the interfaces towards the SN, TE (e.g. telephone, facsimile machine, personal computer, etc.) and network management system are offered. Figure 2 shows a reference model for FWA supported from a PSTN access network solution. As can be seen from Fig. 2, the FWA system includes a possibility to provide services to both fixed and mobile users. This is an important requirement as already pointed out in Recommendation ITU-R M.819.

Open and standard interfaces are used in both network interface and the customer interfaces. This enables, on one hand, switch vendors easily to build independent access networks and on the other hand, end-users to use standard equipment like telephone sets, fax machines, personal computers, etc.

This solution is offered to those operators who need to connect the FWA system directly to the service node (i.e. local exchange). The specific signalling schemes vary from country to country and are standardized by respective PTTs or government regulatory bodies. Thus the signalling in FWA supported from a PSTN access network has to be adapted according to the national fixed public network protocol mapping specifications.

FIGURE 2
A reference model of the FWA supported from a PSTN access network

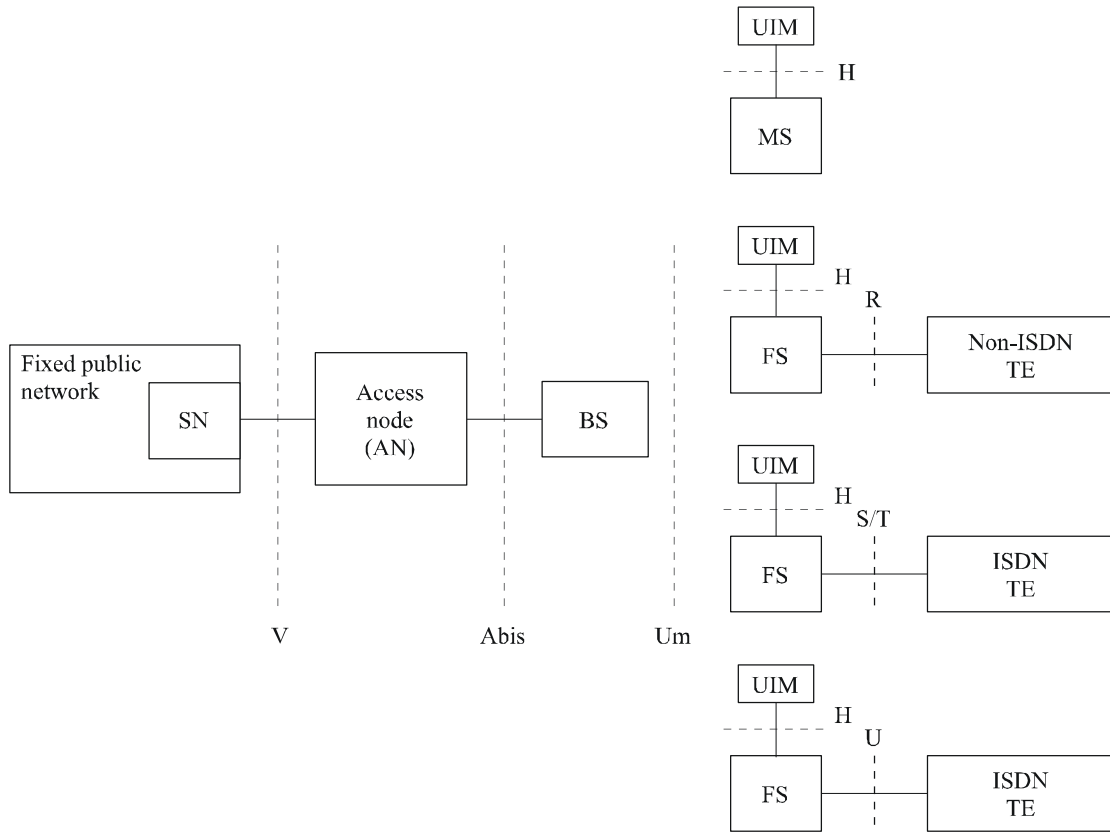

Reference points in Fig. 2

Abis: reference point between the access node and the BS

H: reference point between the MS and the UIM

R: non-ISDN terminal reference point. 2-wire interface is one example of such interface

S/T: standard ISDN reference point. For example ITU-T Recommendation I.430 or according to some other ISDN interface

U: standard ISDN reference point

Um: reference point between the FS (or MS) and the BS

V: reference point between AN and SN. For example standard V5 interface according to ITU-T Recommendation or 2-wire connections

5 Mobility of FWA terminals

In order to fulfil different operators' needs, a possibility to use different FWA terminals (fixed and mobile) may offer the option of limited mobility. In addition to this different degrees of mobility for terminals are needed. Each operator can choose the best suitable terminal configuration (no mobility, restricted mobility, etc.) for operator's FWA system.

5.1 FWA supported from a mobile network

- Optimized for residential use (for example one per household);
- operator should be able to allow limited portability according to operators license agreement;
- operator should be able to restrict portability with the accuracy which is available in the mobile system.

5.2 FWA supported from a PSTN access network

- Optimized for residential use inside access network area;
- operator should be able to allow limited portability according to operators license agreement;
- operator should be able to restrict portability with the accuracy which is available in the mobile system.

6 FWA call set-up procedures

In order to satisfy the needs of different customers (operators and end-users) there needs to be two different call set-up procedure modes for both FWA systems: the transparent mode and the non-transparent mode.

Transparent mode offers shorter call set-up delays and ensures the user that the speech path is already connected before dialling. Because dial tone comes from a service node (MSC or SN), it takes longer time to get dial tone. Non-transparent call set-up mode has longer call set-up times and a drawback that it is not ensured that the speech path is already connected before dialling. However, in non-transparent mode it is faster to get dial tone because it comes from the FWA terminal.

6.1 FWA supported from a mobile network

6.1.1 Transparent mode

In the transparent mode the transmission path is established between the FS and MSC by off-hook ensuring the user that the speech path is already connected before dialling. Figure 3 shows basic principles for transparent mode in FWA supported from a mobile network.

FIGURE 3
 Basic principles for transparent mode in FWA supported from a mobile network

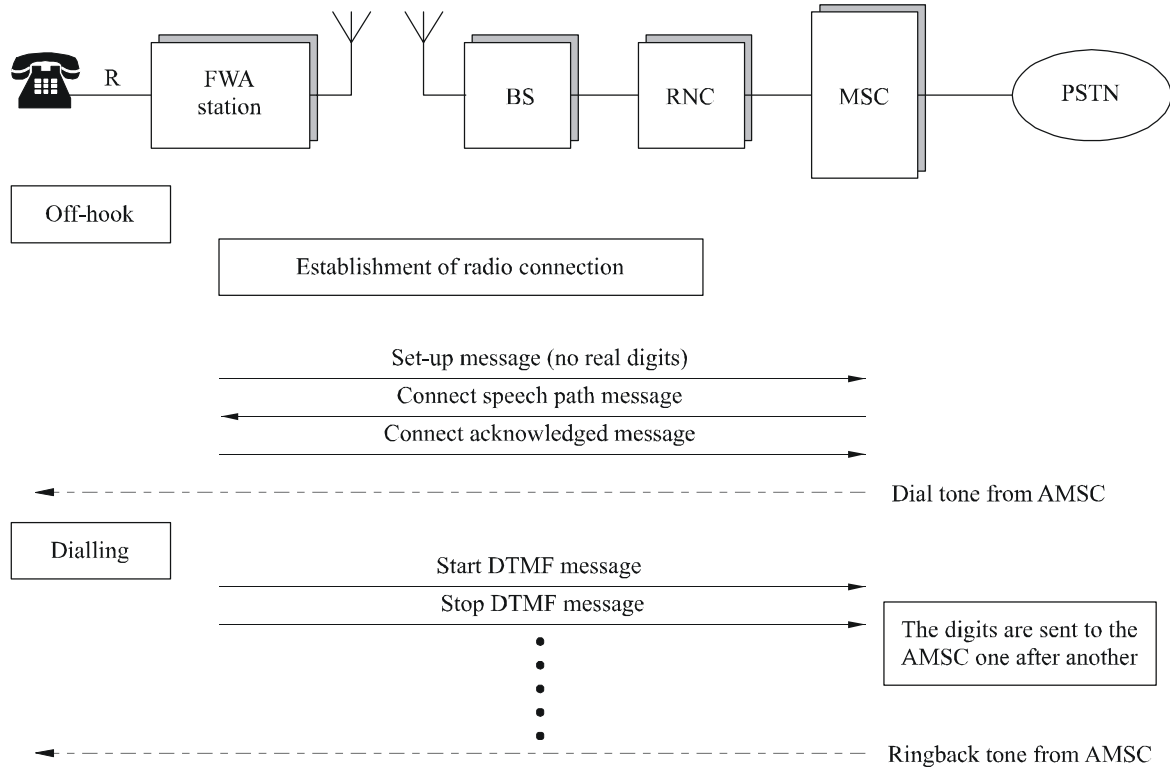

AMSC: anchor mobile switching centre
 DTMF: dual tone multi-frequency
 R: see Fig. 1 reference point

6.1.2 Non-transparent mode

Figure 4 shows basic principles for non-transparent mode in FWA supported from a mobile network.

FIGURE 4
Basic principles for non-transparent mode in FWA supported from a mobile network

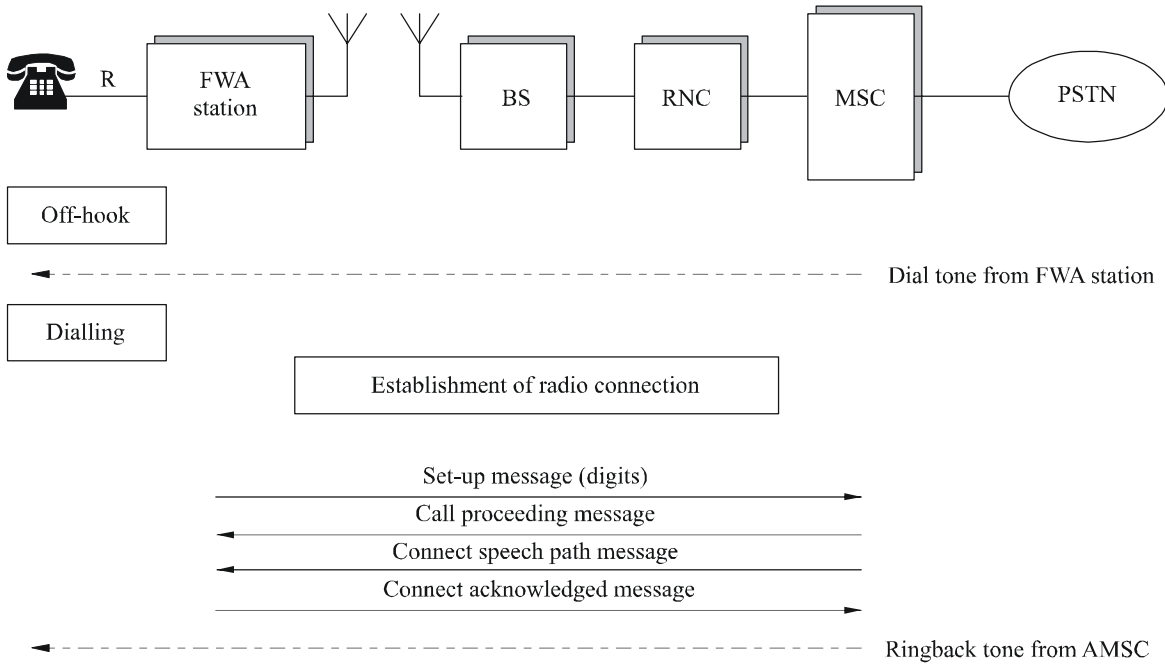

R: see Fig. 1 reference point

1490-04

6.1.3 Mixed mode

A mixed mode can also be used so that when off-hook occurs, the subscriber receives dial tone and digit collect proceeds (just like non-transparent mode) and simultaneously a radio connection is established (just like transparent mode). Once all the digits are collected, then the radio connection can be used.

6.2 FWA supported from a PSTN access network

6.2.1 Transparent mode

In the transparent mode the transmission path is established between the FS and SN by off-hook ensuring the user that the speech path is already connected before dialling. Figure 5 shows basic principles for transparent mode in FWA supported from a PSTN access network.

6.2.2 Non-transparent mode

Figure 6 shows basic principles for non-transparent mode in FWA supported from a PSTN access network.

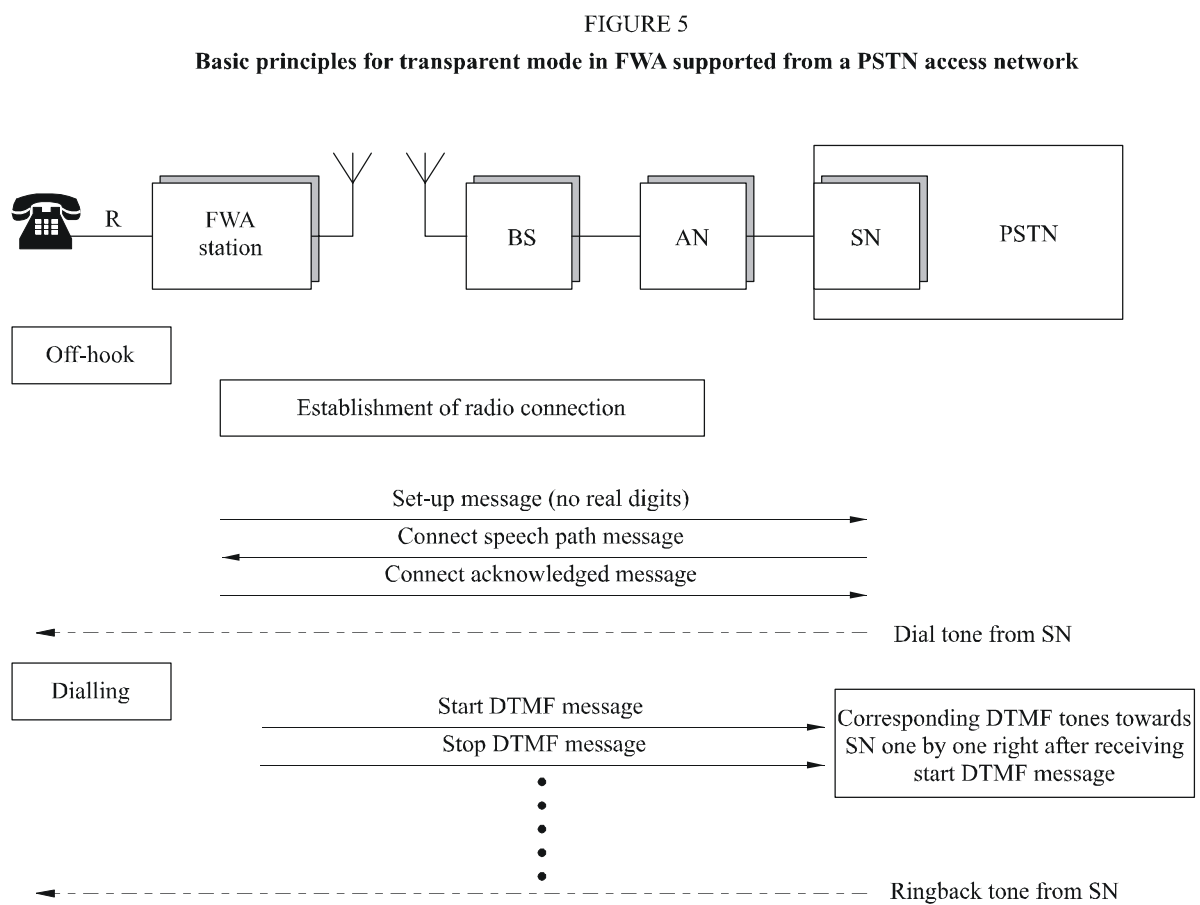

R: see Fig. 1 reference point

FIGURE 6
Basic principles for non-transparent mode in FWA supported from a PSTN access network

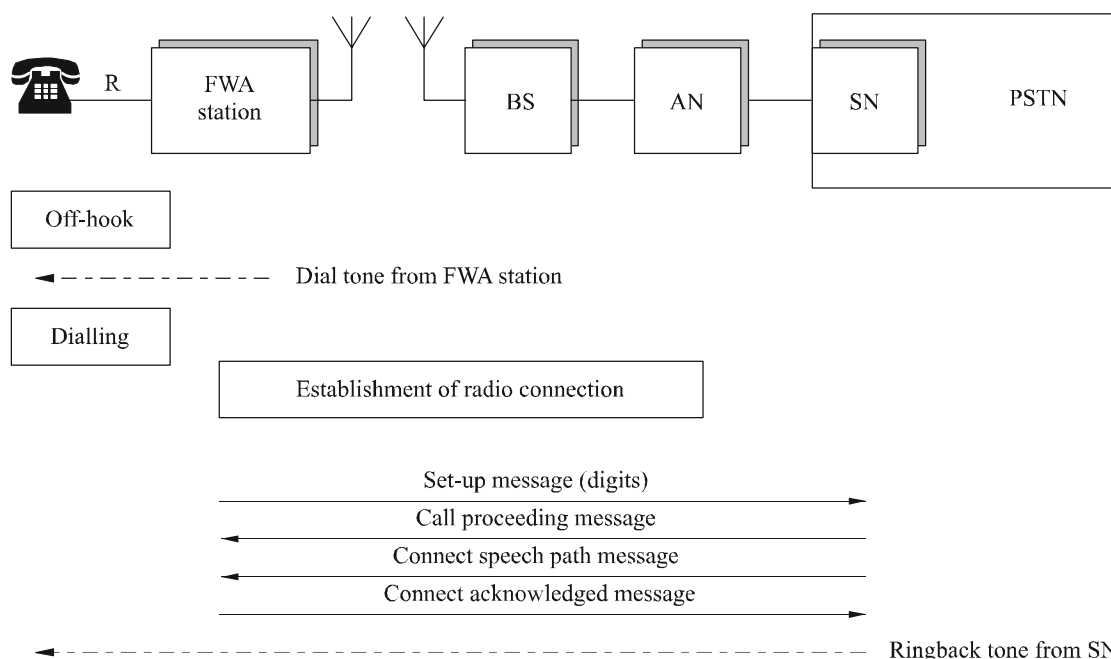

R: see Fig. 1 reference point

1490-06

6.2.3 Mixed mode

A mixed mode can also be used so that when off-hook occurs, the subscriber receives dial tone and digit collect proceeds (just like non-transparent mode) and simultaneously a radio connection is established (just like transparent mode). Once all the digits are collected, then the radio connection can be used.

7 Network management

7.1 General

Network management of FWA network elements (e.g. alarms of faulty BS) may be handled either as for the mobile service system or as for the fixed service network. In addition to mobile system network management, the FWA system should support FS management including: remote testing, configuration of the subscriber FS, subscriber tests (terminal interface test, access link test, etc.) and software downloading (software downloading should be done in similar methods as in mobile system) to the subscriber wireless unit.

Network management of FS is carried mainly by access node related functions/elements in the FWA based on access system and by MSC related functions/elements in the FWA based on mobile service system and includes elements up to fixed service station.

In the case of mobile network, control and maintenance of a FWA terminal could be implemented by using the mobile system's short message service (SMS) or related slow bit rate media, as a carrier. Figure 7 shows basic (high level) principles of control and maintenance.

FIGURE 7
Example of control and maintenance function

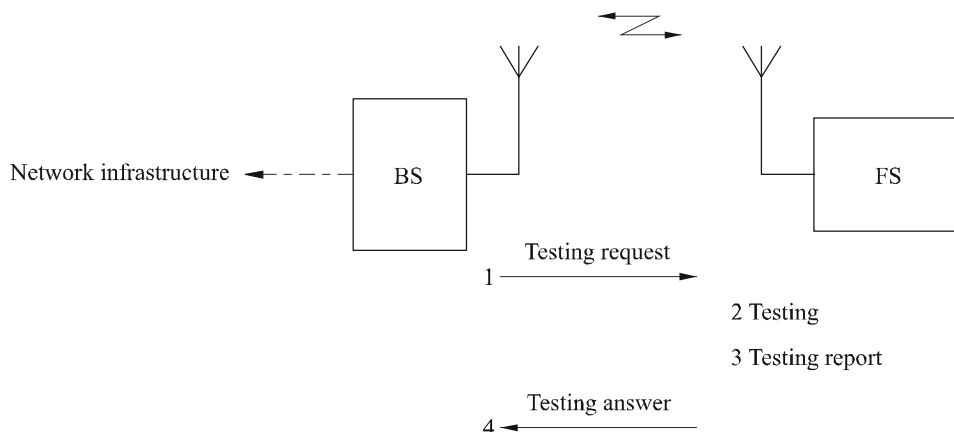

1490-07

7.2 Radio connection performance monitoring

There should be a possibility to measure and monitor the following parameters: signal levels, BER, power levels, etc. It is important that these parameters can be monitored, because the terminal can be mounted to the wall for a long time and thus there can be some unexpected changes in the environment over the years (for example new buildings in the neighbourhood, etc.).

7.3 Fault management

Because the operation of the FWA FS must be ensured in all conditions, there is a need to use some kind of testing procedures to get constant reports concerning faulty FS. One example way to test the FS is to make a special test call from BS to FS to which the FS needs to answer with a predetermined message without alerting the subscriber. Such tests can be executed whenever necessary (for example during low traffic time like at night time) or the test can depend on the traffic load.

7.4 Other electrical parameters management

There needs to be some form of testing procedure in order to monitor the electrical parameters of the FS: loop status, operation voltages and loop current of 2-wire interface and the charge level of the battery backup unit (if the battery backup unit is installed).

7.5 Configuration management

There should be a possibility to make some configurations over the air: feature status query, activation of new features, deactivation of new features, download an enhanced software load to the FS, etc.

7.6 Security management

Some form of security management should be supported by the system in order to detect and prevent misuses of the FSs.

7.7 Mobility management

Some form of flexible mobility management should be supported by the system if any mobile terminals are envisaged or to maintain reliable BS-FS transmission using macro diversity. Note some simple FS may not be capable of generating mobility messages, but should as a minimum respond with a function not supported message to any mobility management query.

8 Other issues

8.1 Charging capabilities

The FWA system should have sufficient charging (billing) flexibility to adapt to different charging schemes and be capable of being configured for special conditions where mobility between cells, or even within a cell, is not required. The main requirement for FWA is for fixed service but also restricted mobility within a cell and between cells should be considered.

8.2 Facsimile

Analogue Group 3 facsimile should be supported by the system. One possible implementation is the use of PCM codec for Group 3 facsimile in order to reduce processing delay problems and unnecessary protocol conversions. Note that a 64 kbit/s PCM bearer may be undesirable for FWA, even if available due to the inefficient use of resources.

8.3 Payphone

FWA system should support functions of different kind of payphones (coin phones, credit phones, etc.). Tariffing for the payphones is based on the Advice of Charge information supported by the system.

In the case of existing coin phones, after FS has received tariff frame (advice of charge message), it generates requested amount of pulses to payphone interface.

Annex 1

Configuration of P-MP FWA systems used in the local grade portion of an ISDN connection

1 Introduction

This Annex describes a typical basic access ISDN connection infrastructure and the general principles of the use of P-MP FWA systems for connection of central station and outlying (subscriber or remote) stations.

2 Local grade portion of an ISDN connection

An ISDN basic access comprises:

- two 64-kbit/s B-channels for carrying information in circuit mode and packet mode,

– one 16-kbit/s D-channel for carrying signalling and packet-mode data.

An ISDN basic rate may therefore be represented as in Fig. 8:

FIGURE 8
ISDN basic access configuration

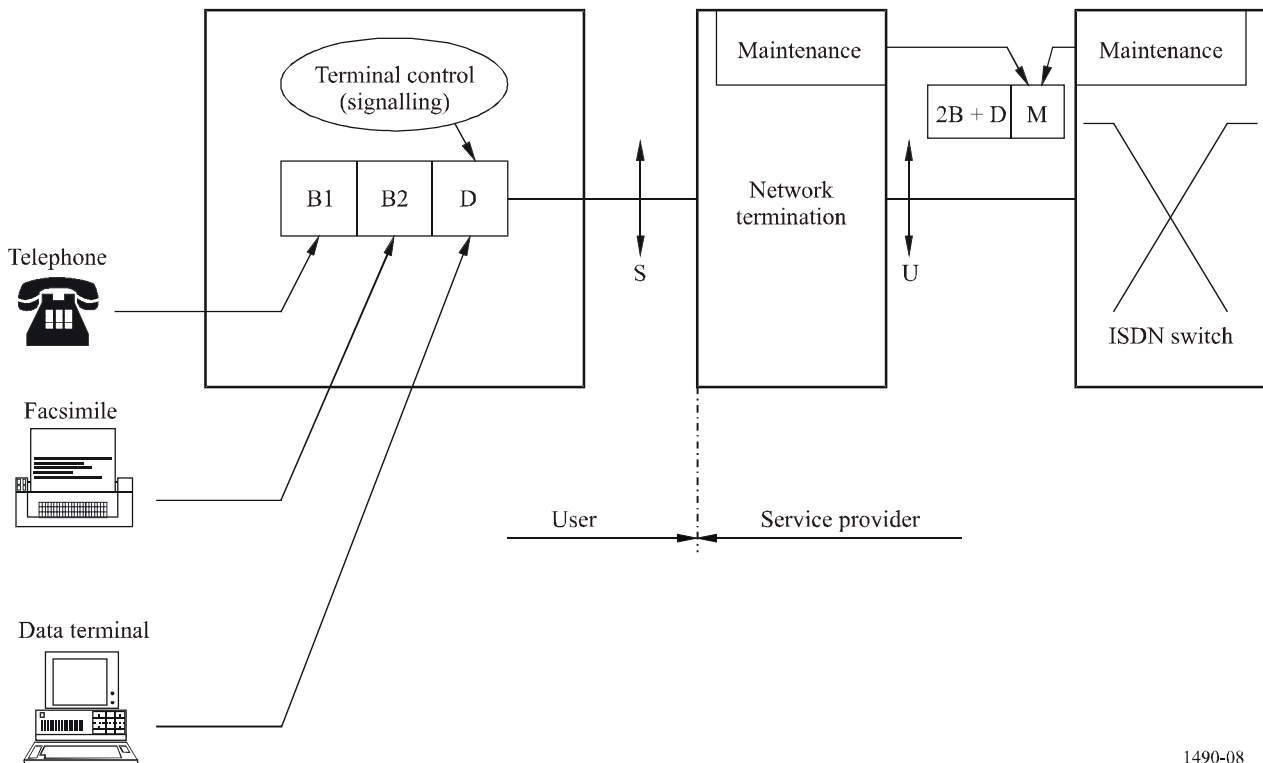

1490-08

Clearly, the B signals are readily transmissible in the 64 kbit/s time-slots of a P-MP FWA system.

On the other hand, the information contained in the D-channel requires channels with appropriate bit rates.

3 Position of P-MP FWA systems in the network

P-MP FWA systems are used in the access portion of the service provider network. In the case of the ISDN, this means that P-MP FWA systems are inserted at the U reference point interface. Some applications, such as connection of private subscribers to ISDN PABXs are performed at the S reference point interface.

With the S interface, radio equipment can be designed to connect with exchanges in such a way as to provide advanced functions such as lost call procedures. These functions are not required in a cable system. With the S interface, acquisition of information about circuit activation/deactivation is also possible. This implies that a simple "translation" of this information would enable the P-MP FWA system to use a demand assignment, multiple access technique. On the other hand, the U interface has the advantage that it allows connection to any standard terminal equipment and subscriber transmission line. Nevertheless, the U interface involves a very important maintenance aspect. The parent exchange of the P-MP FWA system should have a total maintenance overview of the section comprising the U interface, the network digital terminal (NT) and the S interface connecting the subscriber.

4 ISDN applications – System capacity

4.1 Applications

During the ISDN introduction phase or for the implementation of a few ISDN basic access subscribers in a P-MP FWA system, two solutions can be foreseen:

4.1.1 Using three ITU-T Recommendation G.703 64 kbit/s circuits, the ISDN subscriber loop connection using a P-MP FWA system is shown in Fig. 9.

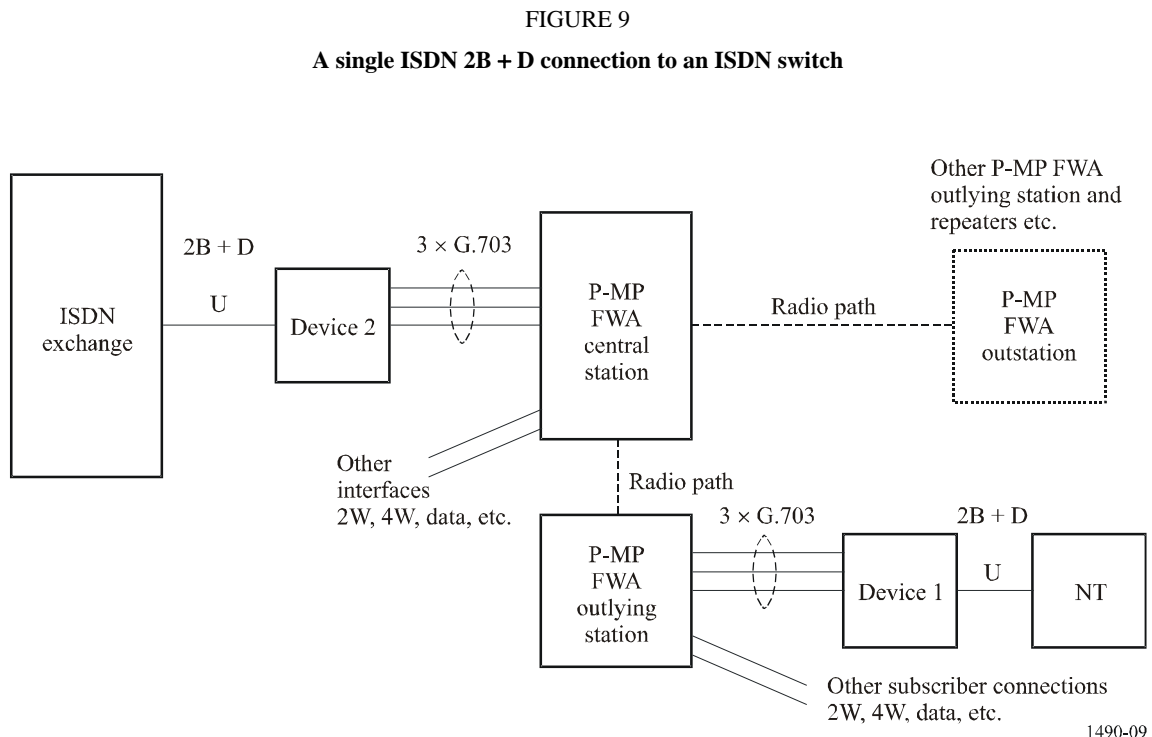

For devices 1 and 2 see Note 1 at the end of § 4.1.1.

At the subscriber end the connection is a U interface into an NT, at the standard ISDN 2B + D basic access 160 kbit/s (2B1Q line encoding) rate.

Device 1 (see Note 1) connects to the U interface of the NT and converts the signal to three ITU-T G.703 co-directional 64 kbit/s signals. Each of two of these ITU-T G.703 signals handles one of the B-channels, while the third handles the D-channel plus synchronization and maintenance data information, which enables the integrity of the 2B + D signal to be maintained through the P-MP system. Since 64 kbit/s ITU-T G.703 co-directional interfaces are generally available on P-MP FWA systems, three such interfaces can readily be used to carry the three 64 kbit/s signals to the central station (C/S). At the C/S the reverse process occurs and the three 64 kbit/s signals are converted in device 2 (see Note 1) to a U interface again – an exact replica of that from the NT. This U interface is then connected to the ISDN switch in the usual way, providing access to the ISDN itself.

The P-MP FWA system can, of course, carry many different types of traffic (2W voice, 4W, data, etc.) simultaneously with ISDN services. A number of ISDN 2B + D signals may be carried through the P-MP system from various locations into the ISDN providing interconnectivity between each other and the ISDN as a whole.

This method offers a relatively straightforward way of adding ISDN circuits to an existing P-MP FWA system without any down time. A number of ISDN circuits may be implemented economically on new systems which may be useful in the provision of ISDN services.

NOTE 1 – Devices 1 and 2 may be included in the P-MP FWA system or physically separate.

4.1.2 Another solution uses only two and a half circuits (i.e. two ITU-T Recommendation G.703 64 kbit/s circuits, plus one 32 kbit/s circuit) for the transmission of the basic rate (2B + D). This solution permits the carrying of the D-channel somewhat more efficiently, whilst retaining many of the features of solution 4.1.1.

4.2 Effect on the system capacity

Demand assignment of circuits is preferred when more efficient use of the frequency spectrum is desired. For example, if fixed assignment is used, an FWA system which has 30 circuits capacity could only accommodate 10 (for solution 4.1.1) to 12 (for solution 4.1.2) subscribers, providing them with 2B + D basic interface service. In contrast, use of demand assignment of 2B + D circuits provides a traffic capacity of 5.9 E with a lost call rate of 1%. Consequently a system with the same transmission capacity could accommodate about 60 subscribers with 0.1 E call rate.

Similarly, 20 channels of B + D could be provided when most subscribers use only one B-channel. In this case, the FWA system can provide a traffic capacity of 12.0 E for 120 subscribers. Consequently, demand assignment and individual channel assignment are preferable from the viewpoint of frequency.

While demand assignment procedures are relatively straightforward to implement for the connection at the S reference point (as mentioned in § 3), such procedures are more complex for the connection at the U reference point.

Annex 2

Examples of methods for demand assignment, multiple access of ISDN links on a P-MP FWA system

1 Introduction

This Annex describes two possible methods for the assignment on demand of ISDN circuits on a P-MP FWA system.

2 First method: P-MP FWA system as an ISDN repeater

This method consists of considering the P-MP FWA system as an ISDN repeater: this architecture requires the allocation of a half time-slot (one time-slot: 64 kbit/s, half a time-slot: 32 kbit/s) per declared ISDN subscriber in order to transmit transparently the D-channel and maintenance to the ISDN terminal (16 kbit/s are used for the D-channel and 16 kbit/s for the maintenance channel). The B-channels are allocated dynamically according to subscriber needs by decoding of the 1, 2 and 3 layers of the ISDN protocol and detailed analysis of the resultant signalling.

In such a case, the interfaces between the ISDN switch and central station can either be individual U type or multiplex type ($12 \times (2B + D)$) at 2.048 Mbit/s).

2.1 Advantages

- The P-MP FWA system preserves its role as a repeater and has a clear status which is provided for in the present ISDN Recommendations.
- The D-channel protocol is passed transparently between the ISDN switch and the subscriber (resources are always available).
- Maintenance signalling is passed transparently to the subscriber-side U interface at the outlying station so that the switching exchange can control the NT on the subscriber's premises and permanently supervise transmission quality.

2.2 Disadvantages

- A half time-slot is permanently occupied for each declared ISDN subscriber, which means that the number of ISDN subscribers per system is limited.

3 Second method: P-MP FWA system as an ISDN concentrator

3.1 General description

With this architecture, the P-MP FWA system using TDMA scheme dynamically allocates the ISDN B-channels according to demand and concentrates the D-channels.

The data flow over the D-channels is sporadic and it is more efficient to concentrate all the ISDN subscriber signalling channels in one $n \times 64$ kbit/s signalling link than to provide a 16 kbit/s channel for each ISDN subscriber.

This method therefore enables the number of subscribers to be optimized in terms of the system resources available. However, this architecture raises the issue of the place of the P-MP transmission in the network; the very important aspect of maintenance at the U interface becomes more complex to manage and time delays which occur in the system may also give rise to difficulties. The P-MP FWA system using TDMA scheme itself may have to send maintenance tests over the U interfaces at the outlying station and supervise their transmission quality. Subject to these limitations the use of basic or primary rate interfaces between the central station of the P-MP FWA system and the ISDN switch is possible.

3.2 Transmission of signalling data and the D packet between the central station and outlying stations

The first solution is to pass the signalling information plus the D packet data over the same signalling link (which will be a multiple of 64 kbit/s).

The second solution involves a separation on transmission of the signalling part in the D-channel from the packet part in the same D-channel.

3.2.1 Single signalling plus D packet channel

Since signalling between the ISDN automatic switching exchange and the central station is transmitted over point-to-point links, there is no collision due to random access. That is not the case in a P-MP FWA system between outlying stations and the central station, because the outlying stations transmit over the signalling channel in random access. If the number of collisions rises excessively in the signalling channel, communication over that channel loses much of its efficiency. This means that the dimensioning of the internal signalling channel is important.

Two methods may be applied, one static and the other dynamic.

3.2.1.1 Static dimensioning of the internal signalling channel

Under this dimensioning mode, the network operator allocates a fixed number of time-slots to the signalling link, depending on the total number of ISDN subscribers served by the P-MP FWA system and the number of ISDN subscribers who have taken out a D packet subscription.

3.2.1.2 Dynamic dimensioning of the internal signalling channel

In this case, according to the number of collisions occurring in the outlying station-to-central station direction within the signalling link and the transmission delay incurred, the software establishes new time-slots or releases surplus ones. Similarly, in the central station-to-outlying station direction, the software adapts the number of signalling link time-slots according to the length of the transmission queue.

NOTE 1 – Data recovery is a complex matter whichever method is used, since information which may be transiting in different time-slots must be properly re-ordered.

3.2.2 Signalling and D packets carried independently

The approach for this architecture is different. The principle is to separate the signalling in the D-channel from the D packet and to transmit each of them independently.

Although more complex to manage, this method should permit full optimization of the time-slots used for transmitting the information contained in the different D-channels of all ISDN subscribers.

3.2.2.1 Signalling

ISDN signalling will travel over a signalling link at $n \times 64$ kbit/s. Such a signalling link will have random access in the outlying station-to-central station direction. It will be dimensioned either dynamically or statically, as indicated in § 3.2.1.

3.2.2.2 The D packet

D packets will travel over a sub-rate link. Initial signalling information is passed over the random-access signalling link in order to establish the sub-rates.

With this method, X.25 level 3 management is conducted to monitor the line and determine the X.25 “D packet” communication requirements (X.25 call set up/release, necessary bit rate, etc.).

4 Summary

The second architecture, which confers on the P-MP FWA system using TDMA scheme a genuine ISDN concentrating role, is the most efficient in terms of resource occupancy. However, the notion of an ISDN concentrator is not yet defined in the Recommendations on the local grade portion of the ISDN connection.

The solution of a P-MP FWA system as a repeater at the U interface level providing D-channel and maintenance channel transparency may be well suited to the current network architecture where both ISDN and non-ISDN circuits may be present.
