

International Telecommunication Union

ITU-R
Radiocommunication Sector of ITU

Recommendation ITU-R BT.2077-2
(06/2017)

**Real-time serial digital interfaces
for UHDTV signals**

BT Series
Broadcasting service
(television)



Foreword

The role of the Radiocommunication Sector is to ensure the rational, equitable, efficient and economical use of the radio-frequency spectrum by all radiocommunication services, including satellite services, and carry out studies without limit of frequency range on the basis of which Recommendations are adopted.

The regulatory and policy functions of the Radiocommunication Sector are performed by World and Regional Radiocommunication Conferences and Radiocommunication Assemblies supported by Study Groups.

Policy on Intellectual Property Right (IPR)

ITU-R policy on IPR is described in the Common Patent Policy for ITU-T/ITU-R/ISO/IEC referenced in Annex 1 of Resolution ITU-R 1. Forms to be used for the submission of patent statements and licensing declarations by patent holders are available from <http://www.itu.int/ITU-R/go/patents/en> where the Guidelines for Implementation of the Common Patent Policy for ITU-T/ITU-R/ISO/IEC and the ITU-R patent information database can also be found.

Series of ITU-R Recommendations

(Also available online at <http://www.itu.int/publ/R-REC/en>)

Series	Title
BO	Satellite delivery
BR	Recording for production, archival and play-out; film for television
BS	Broadcasting service (sound)
BT	Broadcasting service (television)
F	Fixed service
M	Mobile, radiodetermination, amateur and related satellite services
P	Radiowave propagation
RA	Radio astronomy
RS	Remote sensing systems
S	Fixed-satellite service
SA	Space applications and meteorology
SF	Frequency sharing and coordination between fixed-satellite and fixed service systems
SM	Spectrum management
SNG	Satellite news gathering
TF	Time signals and frequency standards emissions
V	Vocabulary and related subjects

Note: This ITU-R Recommendation was approved in English under the procedure detailed in Resolution ITU-R 1.

Electronic Publication
Geneva, 2017

© ITU 2017

All rights reserved. No part of this publication may be reproduced, by any means whatsoever, without written permission of ITU.

RECOMMENDATION ITU-R BT.2077-2

Real-time serial digital interfaces for UHD TV signals

(Question ITU-R 130-2/6)

(06/2015-10/2015-2017)

Scope

This Recommendation defines Serial Digital Interfaces for UHD TV studio signals with $7\,680 \times 4\,320$ and $3\,840 \times 2\,160$ pixel counts, various frame frequencies up to 120 Hz, 4:4:4, 4:2:2, and 4:2:0 sample structures, and 10 and 12 bit depths defined in Recommendations ITU-R BT.2020 and ITU-R BT.2100. This Recommendation is divided into three parts. Part 1 and Part 3 are based on 10-bit word containers and Part 2 is based on 12-bit word containers. Part 1 and Part 2 use multi-link 10 Gbit/s optical interfaces and Part 3 uses single link and multi-link 6 Gbit/s, 12 Gbit/s and 24 Gbit/s electrical and optical interfaces.

Keywords

Serial Interface, UHD TV, Optical Interface, Sub-Image, Real-Time

The ITU Radiocommunication Assembly,

considering

- a)* that Recommendation ITU-R BT.2020 defines UHD TV studio signals with $7\,680 \times 4\,320$ and $3\,840 \times 2\,160$ pixel counts, various frame frequencies up to 120 Hz, 4:4:4, 4:2:2, and 4:2:0 sample structures, wide colour gamut, and 10 and 12 bit depths;
- b)* that Recommendation ITU-R BT.2100 defines image parameter values for high dynamic range television for use in production and international programme exchange and contains the image formats having the same parameter values as defined in Recommendation ITU-R BT.2020 except for the following parameters:
 - transfer functions of the perceptual quantization (PQ) and the Hybrid Log-Gamma (HLG);
 - luminance and colour difference signal representations of the non-constant luminance $Y'C'_B C'_R$ and the constant intensity $I_{C_T C_P}$;
- c)* that a whole range of equipment based on these signals requires digital interfaces for broadcasting chains and industrial applications;
- d)* that digital interfaces for UHD TV studio signals should support all UHD TV formats permitted in Recommendations ITU-R BT.2020 and ITU-R BT.2100;
- e)* that high-definition digital interfaces (HD-SDI) specified in Recommendation ITU-R BT.1120 were originally designed to transport 4:2:2, 10 bit HDTV signals at a frame frequency of up to 30 Hz or a field frequency of 60 Hz;
- f)* that practical optical interfaces supporting a data rate of around 10 Gbit/s are available, and practical electrical and optical interfaces supporting data rates of 6 Gbit/s and 12 Gbit/s and 24 Gbit/s are available, and those interfaces supporting higher data rates will become possible in the future,

recommends

that the specifications described in Part 1, Part 2 or Part 3 of this Recommendation should be used for Real-Time Serial Digital Interfaces for UHD TV signals specified in Recommendations ITU-R BT.2020 and ITU-R BT.2100.

NOTE 1 – Table 1 tabulates key characteristics of the Part 1, 2 and 3 interfaces.

Where there is a choice of interfaces for the desired infrastructure, it can be made taking account of operational and other business factors, including the transmission medium and distance as indicated in Table 1.

TABLE 1
Key characteristics of the Part 1, 2 and 3 interfaces

		Part 1	Part 2	Part 3	
				Electrical	Optical
Data mapping	Container	10-bit word	12-bit word	10-bit word	
	Link speed	10.692 Gbit/s	10.692 Gbit/s	5.94, 11.88 or 23.76 Gbit/s	
	Number of links	Up to 16	Up to 24	Up to 8	
Physical layer	Transmission Medium	Single-mode Optical fibre	Single-mode or Multi-mode Optical fibre	Coaxial cable	Single-mode or Multi-mode Optical Fibre
	Number of fibres/cables	1 (DWDM)	1 (DWDM) or 24 (single λ per fibre)	Up to 8	1 (CWDM) or up to 8 (single λ per fibre)
	Connector	LC/PC simplex/duplex	SC/PC simplex or MPO	BNC	LC/PC simplex/duplex
	Transmission distance	<2 km	< 100 m (MM) < 2 km (SM)	< 100 m (6G) < 70 m (12G) < 30 m (24G)	<100 m (MM) <4 km (SM)
Example applications		Inter-studio	In-studio or Inter-studio	In-Studio	In-Studio or Inter-studio

CWDM: Coarse Wavelength Division Multiplex

DWDM: Dense Wavelength Division Multiplex

LC/PC: Lucent Connector

SC/PC: Single fibre Coupling/Physical Contact

MPO: Multiple-Fibre Push-On/Pull-off

NOTE 2 – Throughout this Recommendation ‘_h’ indicates a number in hexadecimal notation, and ‘₍₁₀₎’ indicates a number in decimal notation.

NOTE 3 – The source ultra-high definition television (UHDTV) image sample structures for the interface are defined in Recommendations ITU-R BT.2020 and ITU-R BT.2100 and are listed in Table 2. UHDTV has an image format (sample structure) of 3 840 × 2 160 (UHDTV1) or 7 680 × 4 320 (UHDTV2).

NOTE 4 – Throughout this Recommendation the notation of $Y'C'_B C'_R$ is used to represent luminance and colour difference signals, which may be either $Y'C'_B C'_R$ or $IC_T C_P$ in practice, unless otherwise indicated.

NOTE 5 – When full range data is conveyed and signalled, the data is clipped to the narrow range video data range.

TABLE 2

**Image sample structures and frame frequencies of UHD TV systems supported
by this Recommendation**

System category	System nomenclature	Luminance or R' G' B' samples per line	Lines per frame	Frame frequency (Hz)
UHDTV1	3 840 × 2 160/23.98/P	3 840	2 160	24/1.001
	3 840 × 2 160/24/P			24
	3 840 × 2 160/25/P			25
	3 840 × 2 160/29.97/P			30/1.001
	3 840 × 2 160/30/P			30
	3 840 × 2 160/50/P			50
	3 840 × 2 160/59.94/P			60/1.001
	3 840 × 2 160/60/P			60
	3 840 × 2 160/100/P			100
3 840 × 2 160/119.88/P	120/1.001			
3 840 × 2 160/120/P	120			
UHDTV2	7 680 × 4 320/23.98/P	7 680	4 320	24/1.001
	7 680 × 4 320/24/P			24
	7 680 × 4 320/25/P			25
	7 680 × 4 320/29.97/P			30/1.001
	7 680 × 4 320/30/P			30
	7 680 × 4 320/50/P			50
	7 680 × 4 320/59.94/P			60/1.001
	7 680 × 4 320/60/P			60
	7 680 × 4 320/100/P			100
7 680 × 4 320/119.88/P	120/1.001			
7 680 × 4 320/120/P	120			

PART 1

1 Definition of terms

ANC	Ancillary data packets
UHDTV	Ultra-high definition television, having an image format (sample structure) of $3\,840 \times 2\,160$ or $7\,680 \times 4\,320$
UHDTV1	UHDTV having an image format (sample structure) of $3\,840 \times 2\,160$
UHDTV2	UHDTV having an image format (sample structure) of $7\,680 \times 4\,320$
CRC	Cyclic redundancy check codes defined in Recommendation ITU-R BT.1120
CDR	Clock data recovery
EAV	The term EAV used in Part 1 of this Recommendation designates 4 bytes of timing information around an end of active video area
HANC data	Data included in the digital line blanking interval between EAV/LN/CRC and SAV
K28.5	Special code for the word boundary detection of 8B/10B coding defined in ANSI INCITS 230
LN	Line number data defined in Recommendation ITU-R BT.1120
Container format	The pixel array present on the interface to transport images (for Part 1 of this Recommendation the container is $1\,920 \times 1\,080$)
SAV	Timing information around a start of active video area defined in Recommendation ITU-R BT.1120
Basic stream	A 10-bit parallel stream which has the same structure as the source data stream defined in Recommendation ITU-R BT.1120 This interleaved data stream carries the image structure defined in the source format data defined in Recommendation ITU-R BT.1120
Even basic stream	Channel CH2, CH4, CH6 and CH8 (Link Bs) of basic streams defined in Annex B to Part 1 § B1.4 (Mode D)
Odd basic stream	CH1, CH3, CH5 and CH7 (Link As) of basic streams defined in Annex B to Part 1 § B1.4 (Mode D)
Stuffing data	Designates one of the data byte D0.0 of 8B/10B coding defined in ANSI INCITS 230
LC (Lucent Connector)	IEC 61754-20 (2012), Fibre Optic Connector Interfaces – Part 20: Type LC Connector Family

2 Basic system overview

For UHDTV1, two images should be mapped into 4 or 8 or 16 or 32 sub-images through 2-sample or 2-frame interleave division in the case of 100 Hz and 120 Hz and should be mapped into single-link, dual-link, quad-link, octa-link or sixteen-link 10G-HDSI Mode D defined in Annex B to Part 1 through basic streams that comply with 1.5 Gbit/s Serial Digital Interface defined in Recommendation ITU-R BT.1120 as shown in Fig. 1-1. Switching interface signals mapped according to Part 1 of this Recommendation is restricted to a maximum of 60 Hz. Base band switching is not constrained.

When embedding optional ANC data, the ANC data packet format should be in conformance with Recommendation ITU-R BT.1364. Ancillary audio data should be as defined in Recommendation ITU-R BT.1365 and should be mapped in the following order:

- (1st) CH1 basic stream of 10G-HDSDI Link 1, up to a maximum of 16 channels at a sampling frequency of 48 kHz or up to a maximum of eight channels at a sampling frequency of 96 kHz;
- (2nd) CH1 basic stream of 10G-HDSDI Link 2, up to a maximum of 16 channels at a sampling frequency of 48 kHz or up to a maximum of eight channels at a sampling frequency of 96 kHz.

The multiple numbers of basic streams conveying the source data of UHDTV images should be multiplexed and serialized into a single-link or multiple-link 10G-HDSDI as defined in §§ 3 and 4.

FIGURE 1-1
UHDTV mapping overview

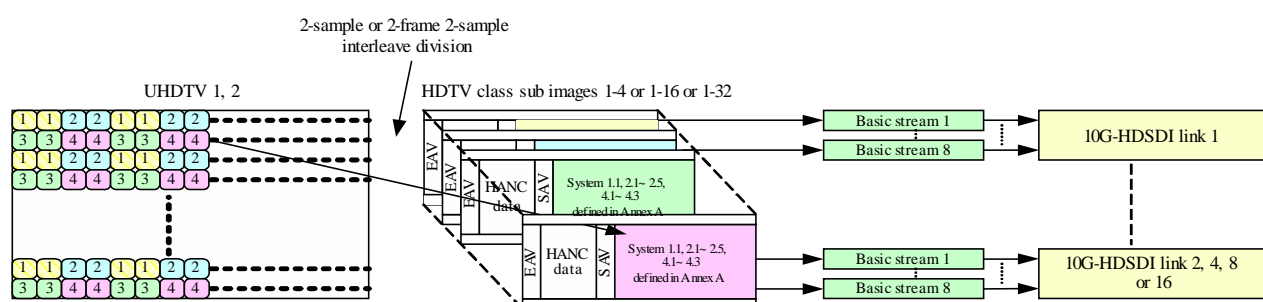

BT.2077-0 1-01

3 UHDTV1 Mapping into single-link or dual-link or quad-link 10G-HDSDI

3.1 Video payload mapping

Table 1-1 shows the image formats which should be divided into four sub-images by 2-sample interleave division or 2-frame 2-sample interleave division and should be mapped into the single-link or the dual-link or the quad-link 10G-HDSDI Mode D defined by Annex B to Part 1. Each sub-image should have the 1 920 × 1 080 image format defined as systems 1.1, 2.1, 2.2, 2.3, 2.4, 2.5, 4.1, 4.2 or 4.3 in Annex A to Part 1, Tables 1-A1, 1-A2 and 1-A3.

TABLE 1-1

Source image formats of UHDTV1 supported by Part 1 of this Recommendation

System Number	System nomenclature	Sampling Structure / Pixel Depth	Frame frequency Hz	Sub-image format defined in Annex A to Part 1
U1.1	3840 × 2160/24/P 3840 × 2160/25/P 3840 × 2160/30/P	4:2:0 or 4:2:2 (Y'C _B C _R)/10-bit	24, 25 and 30 Progressive	System 1.1
	3840 × 2160/23.98/P 3840 × 2160/29.97/P		24/1.001, 30/1.001 Progressive	
U1.2	3840 × 2160/24/P 3840 × 2160/25/P 3840 × 2160/30/P	4:4:4 (R'G'B')/10-bit	24, 25 and 30 Progressive	System 2.2
	3840 × 2160/23.98/P 3840 × 2160/29.97/P		24/1.001, 30/1.001 Progressive	
U1.3	3840 × 2160/24/P 3840 × 2160/25/P 3840 × 2160/30/P	4:4:4 (R'G'B')/12-bit	24, 25 and 30 Progressive	System 2.3
	3840 × 2160/23.98/P 3840 × 2160/29.97/P		24/1.001, 30/1.001 Progressive	
U1.4	3840 × 2160/24/P 3840 × 2160/25/P 3840 × 2160/30/P	4:4:4 (Y'C _B C _R)/10-bit	24, 25 and 30 Progressive	System 2.4
	3840 × 2160/23.98/P 3840 × 2160/29.97/P		24/1.001, 30/1.001 Progressive	
U1.5	3840 × 2160/24/P 3840 × 2160/25/P 3840 × 2160/30/P	4:2:0, 4:2:2 or 4:4:4 (Y'C _B C _R)/12-bit	24, 25 and 30 Progressive	System 2.5
	3840 × 2160/23.98/P 3840 × 2160/29.97/P		24/1.001, 30/1.001 Progressive	
U1.6	3840 × 2160/50/P 3840 × 2160/60/P	4:2:0 or 4:2:2 (Y'C _B C _R)/10-bit	50 and 60 Progressive	System 2.1
	3840 × 2160/59.94/P		60/1.001 Progressive	
U1.7	3840 × 2160/50/P 3840 × 2160/60/P	4:2:0 or 4:2:2 (Y'C _B C _R)/12-bit	50 and 60 Progressive	System 4.1
	3840 × 2160/59.94/P		60/1.001 Progressive	
U1.8	3840 × 2160/50/P 3840 × 2160/60/P	4:4:4 (R'G'B' or Y'C _B C _R)/10-bit	50 and 60 Progressive	System 4.2
	3840 × 2160/59.94/P		60/1.001 Progressive	
U1.9	3840 × 2160/50/P 3840 × 2160/60/P	4:4:4 (R'G'B' or Y'C _B C _R)/12-bit	50 and 60 Progressive	System 4.3
	3840 × 2160/59.94/P		60/1.001 Progressive	
U1.10	3840 × 2160/120/P	4:2:0 or 4:2:2 (Y'C _B C _R)/10-bit	120/1.001 Progressive	System 2.1
U1.10	3840 × 2160/120/P	4:2:0 or 4:2:2 (Y'C _B C _R)/10-bit	120 Progressive	System 2.1
U1.11	3840 × 2160/120/P	4:2:0 or 4:2:2 (Y'C _B C _R)/12-bit	120/1.001 Progressive	System 4.1
U1.11	3840 × 2160/120/P	4:2:0 or 4:2:2 (Y'C _B C _R)/12-bit	120 Progressive	System 4.1

TABLE 1-1 (*end*)

System Number	System nomenclature	Sampling Structure / Pixel Depth	Frame frequency Hz	Sub-image format defined in Annex A to Part 1
U1.12	3840 × 2160/120/P	4:4:4 (R'G'B' or Y'C _B C _R ')/10-bit	120/1.001 Progressive	System 4.2
U1.12	3840 × 2160/120/P	4:4:4 (R'G'B' or Y'C _B C _R ')/10-bit	120 Progressive	System 4.2
U1.13	3840 × 2160/120/P	4:4:4 (R'G'B' or Y'C _B C _R ')/12-bit	120/1.001 Progressive	System 4.3
U1.13	3840 × 2160/120/P	4:4:4 (R'G'B' or Y'C _B C _R ')/12-bit	120 Progressive	System 4.3
U1.14	3840 × 2160/120/P	4:2:0 or 4:2:2 (Y'C _B C _R ')/10-bit	100 Progressive	System 2.1
U1.15	3840 × 2160/120/P	4:2:0 or 4:2:2 (Y'C _B C _R ')/12-bit	100 Progressive	System 4.1
U1.16	3840 × 2160/120/P	4:4:4 (R'G'B' or Y'C _B C _R ')/10-bit	100 Progressive	System 4.2
U1.17	3840 × 2160/120/P	4:4:4 (R'G'B' or Y'C _B C _R ')/12-bit	100 Progressive	System 4.3

System U1.1 through U1.9 images should be divided and mapped into the active area of sub-images one through four by 2-sample interleave division as defined by Fig. 1-A4 in Annex A to Part 1. Sub-images of Systems U1.1 through U1.9 are treated as sub-images of Systems 1.1, 2.2 through 2.5, 2.1 or 4.1 through 4.3 as shown in Table 1-1 and should have the digital sample structure as defined in Recommendation ITU-R BT.2020.

The 0 components of the 4:2:0 (even-numbered samples on odd-numbered lines of unassigned C_BC_R') system image data should be assigned 200_h (512₍₁₀₎) in case of a 10-bit system and 800_h (2 048₍₁₀₎) in case of a 12-bit system.

Table 1-A5 in Annex A to Part 1 specifies the relation between the horizontal/vertical pixel number of the original 3 840 × 2 160 image and the sample/line number of the mapped 1 920 × 1 080 sub-images one, two, three and four by the 2-sample interleave division.

3.2 Single-link 10G-HDSI for Systems U1.1 to U1.5

In the case of Systems from U1.1 to U1.5 images (3 840 × 2 160/23.98/P, 24/P, 25/P, 29.97/P and 30/P), each sub-image one to four created by the 2-sample interleave division should be divided into the single-link or the dual-link 1.5 Gbit/s basic stream. Four single-link or dual-link basic streams from four sub-images should be mapped into the single-link 10G-HDSI as specified in § B1.4 of Annex B to Part 1.

3.3 Dual-link 10G-HDSI for Systems U1.6 to U1.9

In the case of Systems U1.6 through U1.9 images (3 840 × 2 160/50/P, 59.94/P and 60/P), each sub-image data created by the 2-sample interleave division should be divided into the dual-link basic stream or the quad-link basic stream with the same structure as the dual-link 1.5 Gbit/s or the quad-link 1.5 Gbit/s basic streams defined in §§ A1.2 and A1.3 of Annex A to Part 1.

Sub-images one to four generated from System U1.6 images are equivalent to System 2.1 as defined by Annex A to Part 1 and should be divided into eight basic streams as shown in Fig. 1-2.

FIGURE 1-2

8 way division for System U1.6

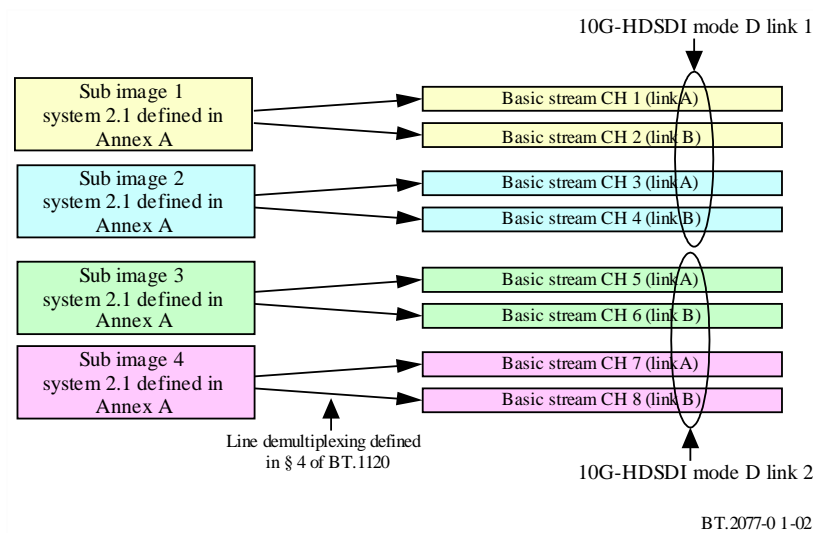

Eight basic streams of a virtual interface for System U1.6 should be mapped into dual-link 10G-HDSDI. Basic streams CH1, CH2, CH3 and CH4 should be mapped into CH1, CH3, CH5 and CH7 (Link As) of 10G-HDSDI Link 1 and basic streams CH5, CH6, CH7 and CH8 should be mapped into CH1, CH3, CH5 and CH7 (Link As) of 10G-HDSDI Link 2, i.e.:

- basic streams CH1, CH2, CH3 and CH4 should be mapped into CH1, CH3, CH5 and CH7 (Link A) of 10G-HDSDI Link 1;
- basic streams CH5, CH6, CH7 and CH8 should be mapped into CH1, CH3, CH5 and CH7 (Link A) of 10G-HDSDI Link 2.

In the case of System U1.7, U1.8 and U1.9 images, sub-images one to four should be divided into 16 basic streams as shown in Fig. 1-3.

FIGURE 1-3
16 way division for Systems U1.7, U1.8 and U1.9

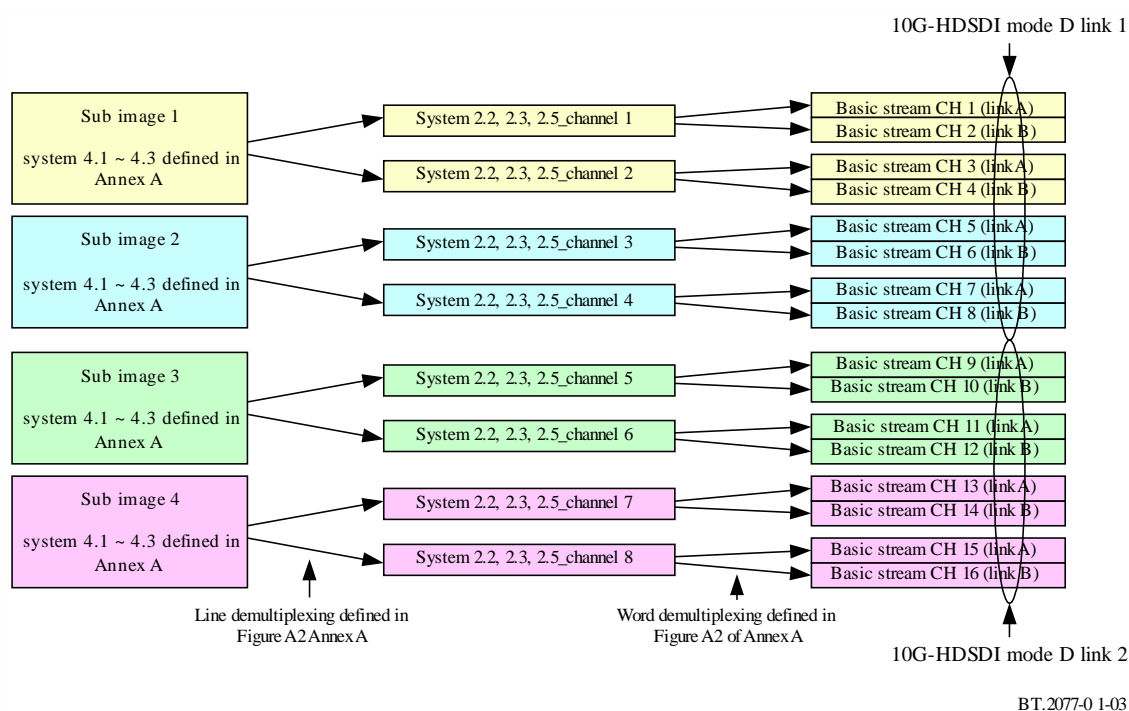

10G-HDSDI Mode D defined by Annex B to Part 1 may transmit up to four pairs of the dual-link 1.5 Gbit/s System 2.2, 2.3, 2.4 or 2.5 or up to two pairs of the quad-link 1.5 Gbit/s System 4.1, 4.2 or 4.3 as defined in Annex B to Part 1. In summary, UHDTV1 images of Systems U1.6, U1.7, U1.8 and U1.9 should be transmitted using a dual-link 10G-HDSDI Mode D.

Sixteen basic streams of a virtual interface for Systems U1.7, U1.8 and U1.9 should be mapped into dual-link 10G-HDSDI. Groups of basic streams CH(8k-7), CH(8k-6), CH(8k-5), CH(8k-4), CH(8k-3), CH(8k-2), CH(8k-1) and CH(8k), where k is a number from one to two, should be mapped into CH1, CH2, CH3, CH4, CH5, CH6, CH7 and CH8 of 10G-HDSDI Link (k), i.e.:

- basic streams CH1 through CH8 should be mapped into CH1 through CH8 of 10G-HDSDI Link 1;
- basic streams CH9 through CH16 should be mapped into CH1 through CH8 of 10G-HDSDI Link 2.

3.4 Quad-link 10G-HDSDI for Systems U1.10 to U1.17

In the case of Systems U1.10 through U1.17 images ($3\ 840 \times 2\ 160/100/P$ or $120/P$), eight sub-image data should be created as per four lines by the 2-frame 2-sample interleave division as shown in Fig. 1-4. Each sub-image should be divided into the dual-link basic stream or the quad-link basic stream with the same structure as the dual-link 1.5 Gbit/s or the quad link 1.5 Gbit/s basic streams defined in §§ A1.2 and A1.3 of Annex A to Part 1.

FIGURE 1-4

2-frame 2-sample interleaving of 3 840 × 2 160/100/P or 120/P mapping onto 8ch of 1 920 × 1 080/50/P or 60/P

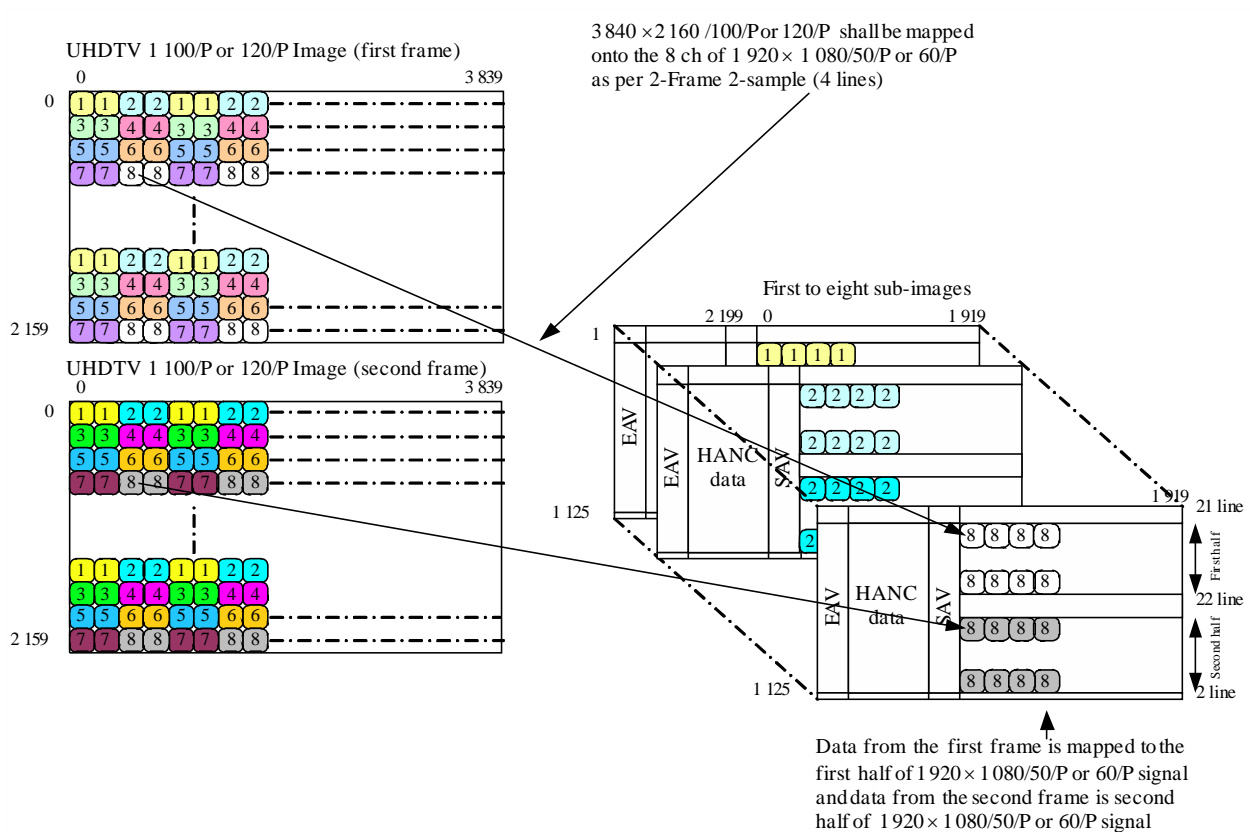

BT.2077-0 1-04

2-frame 2-sample interleave division should be applied to the 3 840 × 2 160/100/P or 120/P images listed in Table 1-1 (U1.10 through U1.16) and should map two consecutive frames, the first frame and the second frame, onto the vertical blanking area and the active area of 8ch of 1 920 × 1 080/50/P or 60/P signals as per 4 lines. 4N, 4N + 1, 4N + 2 and 4N + 3 lines (N = 0, 1, 2, 3 ... 539) from the first and the second frame should be mapped onto the sub-images 1 and 2, sub-images 3 and 4, sub-images 5 and 6 and sub-images 7 and 8 respectively as per two consecutive horizontal samples. The first frame should be mapped onto the line number from 22-line to 561-line and the second frame should be mapped onto the line number from 584-line to 1 123-line. The vertical line blanking from 1-line to 21-line should be inserted before the first frame and the vertical blanking from 562-line to 583-line should be inserted between the first frame and the second frame. Two vertical lines 1 124-line and 1 125-line should be appended after the second frame. This division results in equivalent sub-images 1 through 8.

Figure 1-5 shows the 1 920 × 1 080/50/P or 60/P frame structure in which the vertical blanking areas and the mapped data area from two the first and the second frame of 3 840 × 216/100/P or 120/P images are colour-coded. Table 1-2 defines the relation between sample/line numbers of the original the first and the second frame of 3 840 × 2 160/100/P or 120/P signal and sample/line numbers of the mapped 1 920 × 1 080/50/P or 60/P sub-images 1 through 8 of the 2-frame 2-sample interleaving.

FIGURE 1-5

Image mapping structure and digital timing reference sequences of 1 920 × 1 080/50/P or 60/P images

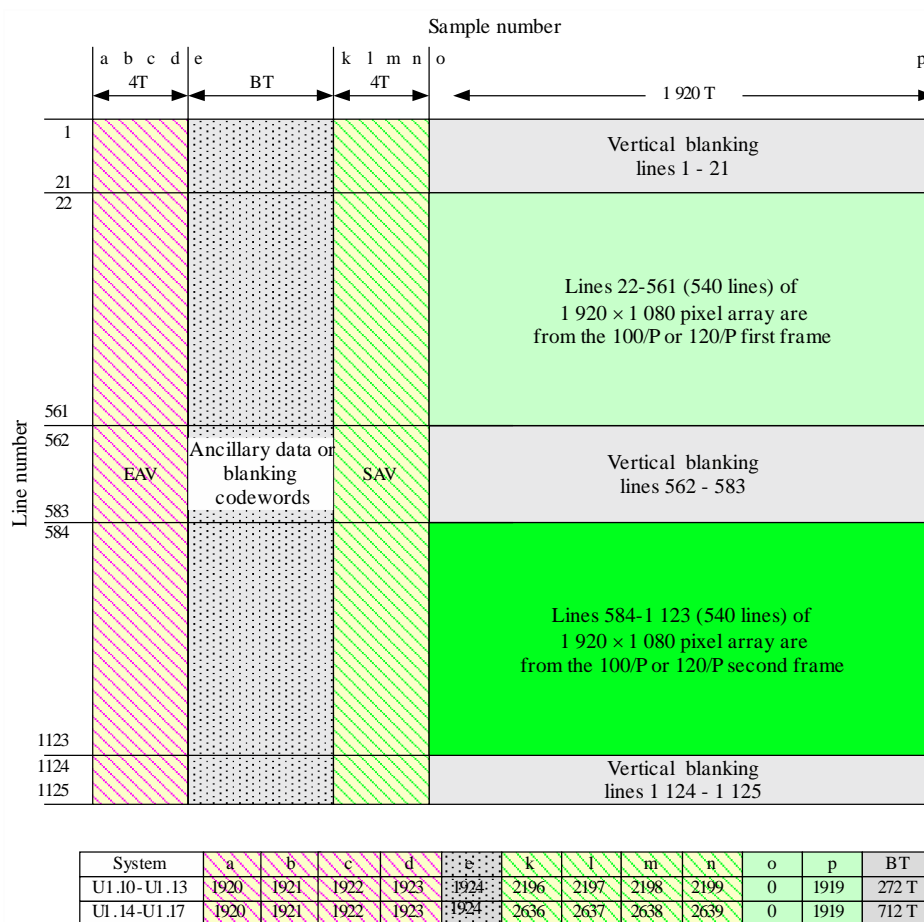

NOTES

1 Horizontal axis not to scale.

2 A line of digital video extends from the first word of EAV through the last word of video data.

3 The number of samples of video data (sample number 'o' through 'p') is 1920. That is, the letter 'o' denotes sample number 0 and the letter 'p' denotes sample number 1919.

4 T is the reference clock period.

TABLE 1-2

Relation between the original image sample/line number from the first and the second frame and the mapped sub-image sample/line number of 2-frame 2-sample interleave division

Sub-image	Original $3\ 840 \times 2\ 160/100/P$ or $120/P$ sample number Original $3\ 840 \times 2\ 160/100/P$ or $120/P$ line number	Mapped $1\ 920 \times 1\ 080/50/P$ or $60/P$ sample number Mapped $1\ 920 \times 1\ 080/50/P$ or $60/P$ line number
1	$4M, 4M + 1$ samples $4N$ line	$2M, 2M + 1$ samples $22 + N$ line (from the first frame) $2M, 2M + 1$ samples $584 + N$ line (from the second frame)
2	$4M + 2, 4M + 3$ samples $4N$ line	
3	$4M, 4M + 1$ samples $4N + 1$ line	
4	$4M + 2, 4M + 3$ samples $4N + 1$ line	
5	$4M, 4M + 1$ samples $4N + 2$ line	
6	$4M + 2, 4M + 3$ samples $4N + 2$ line	
7	$4M, 4M + 1$ samples $4N + 3$ line	
8	$4M + 2, 4M + 3$ samples $4N + 3$ line	

NOTE – $M = 0, 1, 2, 3 \dots 959$, $N = 0, 1, 2, 3 \dots 539$

Sub-images 1 to 8 generated from Systems U1.10 and U1.14 images are equivalent to System 2.1 as defined by Annex A to Part 1 and should be divided into 16 basic streams as shown in Fig. 1-6.

FIGURE 1-6
16 way division for System U1.6

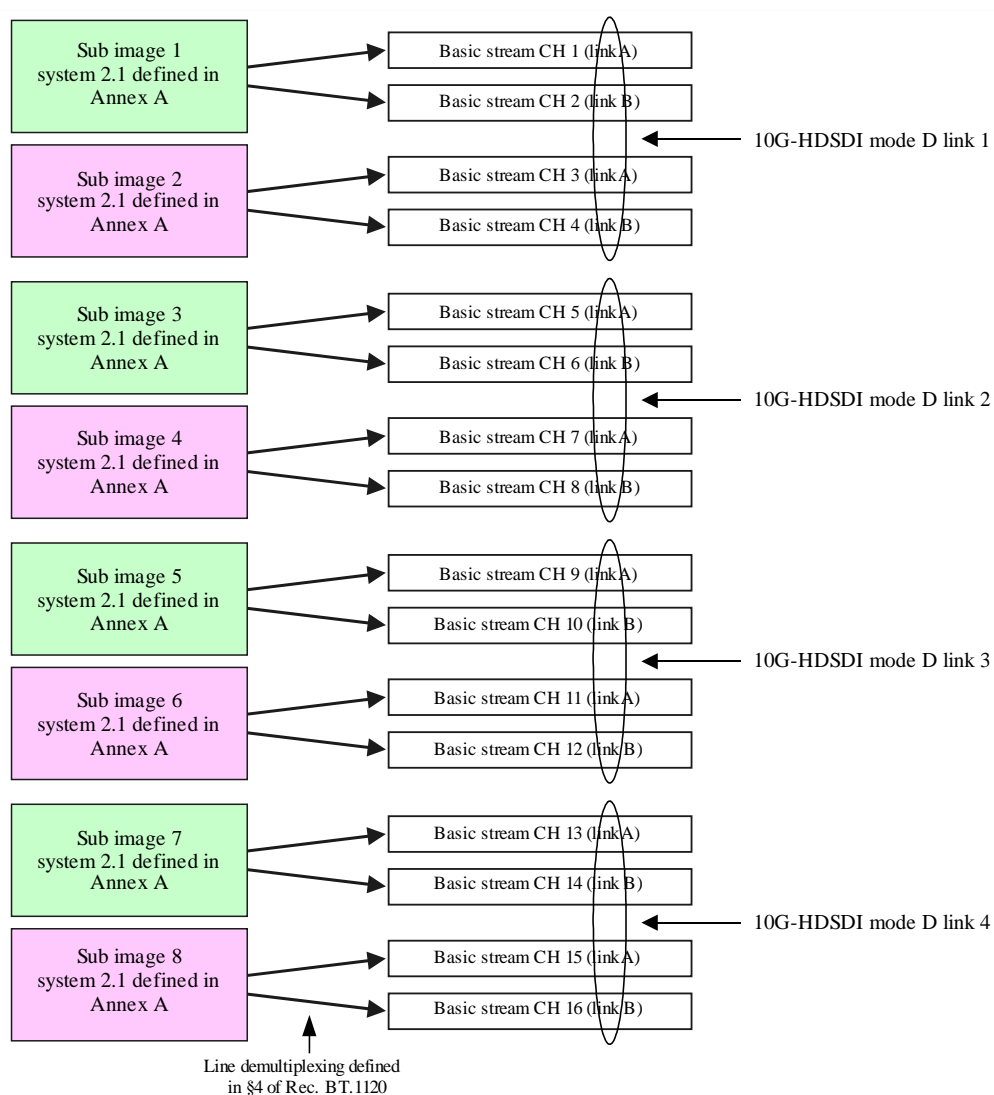

BT.2077-0 1-06

Sixteen basic streams of a virtual interface for Systems U1.10 and U 1.14 should be mapped into quad-link 10G-HDSDI as follows:

- basic streams CH1, CH2, CH3 and CH4 should be mapped into CH1, CH3, CH5 and CH7 (Link As) of 10G-HDSDI Link 1;
- basic streams CH5, CH6, CH7 and CH8 should be mapped into CH1, CH3, CH5 and CH7 (Link As) of 10G-HDSDI Link 2;
- basic streams CH9, CH10, CH11 and CH12 should be mapped into CH1, CH3, CH5 and CH7 (Link As) of 10G-HDSDI Link 3;
- basic streams CH13, CH14, CH15 and CH16 should be mapped into CH1, CH3, CH5 and CH7 (Link As) of 10G-HDSDI Link 4.

In the case of Systems U1.11, U1.12, U1.13, U1.15, U1.16 and U1.17 images, sub-images 1 to 8 should be divided into 32 basic streams as shown in Fig. 1-7.

FIGURE 1-7
32 way division for Systems U1.11, U1.12 and U1.13

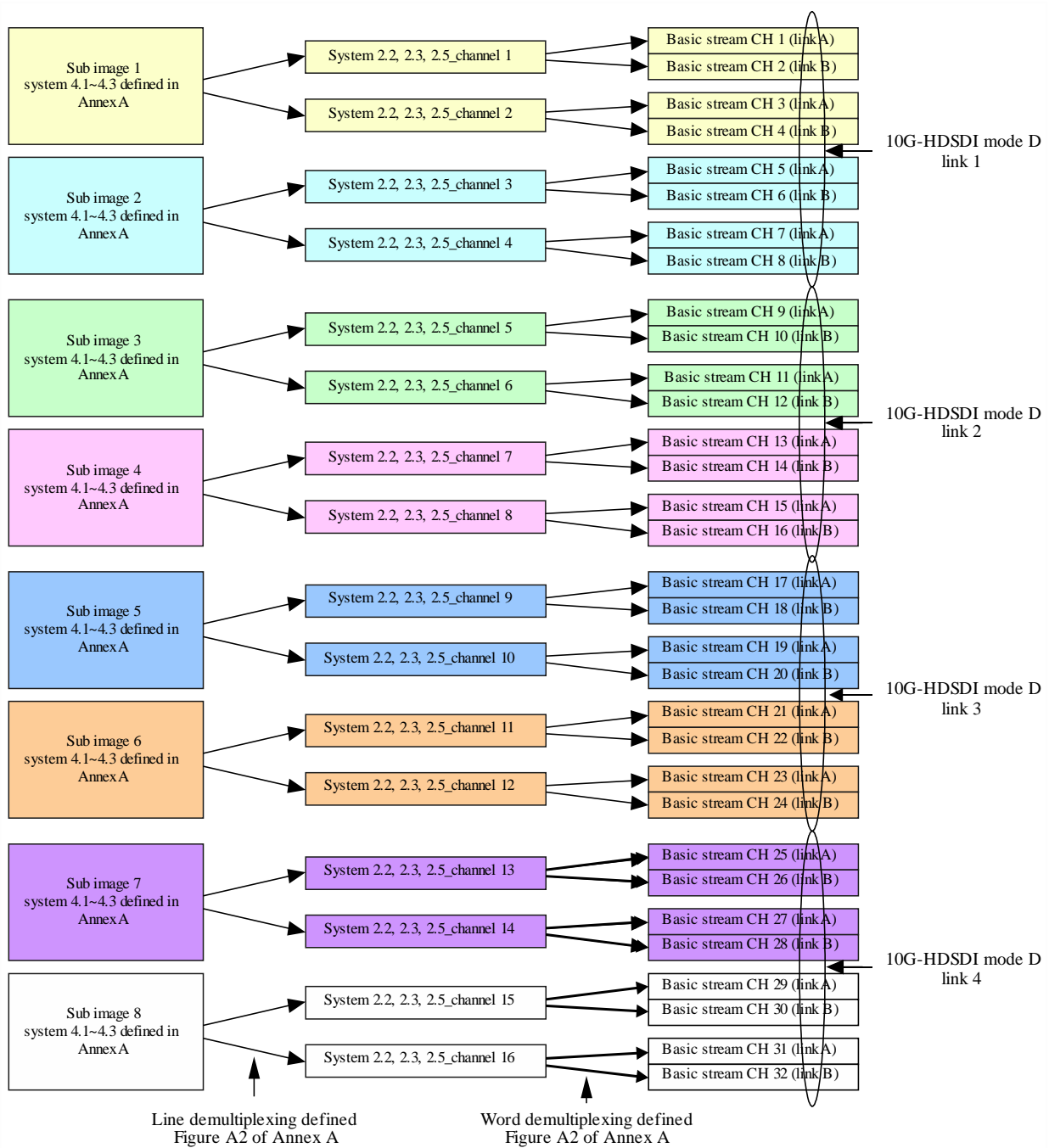

BT.2077-0 1-07

10G-HDSDI Mode D defined by Annex B to Part 1 may transmit up to four pairs of the dual-link 1.5 Gbit/s System 2.2, 2.3, 2.4 or 2.5 or up to two pairs of the quad-link 1.5 Gbit/s System 4.1, 4.2 or 4.3 as defined in Annex B to Part 1. In summary, UHDTV1 images of Systems U1.10 through U1.17 should be transmitted using a quad-link 10G-HDSDI Mode D as defined in Annex B to Part 1.

Thirty-two basic streams of a virtual interface for Systems U1.11, U1.12, U1.13, U1.15, U1.16 and U1.17 should be mapped into quad-link 10G-HDSDI. Groups of basic streams CH(8k-7), CH(8k-6),

CH(8*k*-5), CH(8*k*-4), CH(8*k*-3), CH(8*k*-2), CH(8*k*-1) and CH(8*k*), where *k* is a number from 1 to 4, should be mapped into CH1, CH2, CH3, CH4, CH5, CH6, CH7 and CH8 of 10G-HDSDI Link (*k*), i.e.:

- basic streams CH1 through CH8 should be mapped into CH1 through CH8 of 10G-HDSDI Link 1;
- basic streams CH9 through CH16 should be mapped into CH1 through CH8 of 10G-HDSDI Link 2;
- basic streams CH17 through CH24 should be mapped into CH1 through CH8 of 10G-HDSDI Link 3;
- basic streams CH25 through CH32 should be mapped into CH1 through CH8 of 10G-HDSDI Link 4.

3.5 Optical interface characteristics

The optical interface characteristics of the single-link, the dual-link and the quad-link 10G-HDSDI should be in conformance with Annex C to Part 1.

When transporting the dual-link 10G-HDSDI signal through a single single-mode fibre, the WDM or the DWDM technology may be used. The nominal wavelengths of 1 310 nm and 1 550 nm should be assigned to the Link 1 and 2 for the WDM transport in conformance with Annex C to Part 1. When using DWDM technology, the approximate nominal central wavelengths of 1 557.36 nm and 1 556.55 nm should be assigned to the Link 1 and 2 as listed in Table 1-3. The approximate nominal central wavelengths of 1 557.36 nm, 1 556.55 nm, 1 555.75 nm and 1 554.94 nm should be assigned for the Link 1 through 4 for the 4ch DWDM interfaces.

TABLE 1-3

Nominal central wavelengths of 2ch and 4ch DWDM interface for UHDTV1

Link No.	Approximate nominal central wavelengths for 2ch DWDM	Approximate nominal central wavelengths for 4ch DWDM
1	1 557.36 nm	1 557.36 nm
2	1 556.55 nm	1 556.55 nm
3		1 555.75 nm
4		1 554.94 nm

3.6 ANC/audio data mapping

3.6.1 ANC data mapping

Ancillary data if present should be mapped into the blanking area of CH1 basic stream of 10G-HDSDI. The data format should be in conformance with Recommendation ITU-R BT.1364.

In the case of the dual-link and the quad-link 10G-HDSDI, the ANC data should be mapped into CH1 basic stream of 10G-HDSDI Link 1 first, and any remaining data should be mapped into CH1 of 10G-HDSDI Link 2 through Link 4 in the order of Link 1, Link 2, Link 3 and Link 4.

3.6.2 Audio data mapping

When present, audio data should be mapped into the C'_B/C'_R data stream of the horizontal ANC data space of CH1 basic stream of 10G-HDSDI Link in conformance with Recommendation ITU-R BT.1365 and should be transmitted in groups of four up to a maximum of 16 channel at a

sampling frequency of 48 kHz or up to a maximum of eight channel at a sampling frequency of 96 kHz.

In the case of the dual-link and the quad-link 10G-HDSDI, CH1 basic stream of 10G-HDSDI Link 1 should be used first for audio data transmission in groups of four up to a maximum of 16 channels at a sampling frequency of 48 kHz or up to a maximum of 8 channels at a sampling frequency of 96 kHz in conformance with Recommendation ITU-R BT.1365. If more than 16 channels of audio (8 channels at a sampling frequency of 96 kHz) is required, CH1 basic stream of 10G-HDSDI Link 2 through Link 4 in the order of Link 1, Link 2, Link 3 and Link 4 should be used in conformance with Recommendation ITU-R BT.1365.

The maximum channel number carried by dual-link and the quad-link 10G-HDSDI Mode D is 32 channels and 64 channels at a sampling frequency of 48 kHz or 16 channels and 32 channels at a sampling frequency of 96 kHz.

NOTE – Mode D as defined in Annex B to Part 1 can carry the HANC data included in CH1, 3, 5, 7 basic streams at frame frequencies from 23.98 Hz through 25 Hz. In Part 1 of this Recommendation the audio data is only mapped into the HANC data space of CH1 basic stream irrespective of frame frequency.

Audio control packets should be mapped into the “Y” data stream of the horizontal ANC data space of CH1 basic stream of 10G-HDSDI Link 1 and Link 2 through Link 4 (if necessary), and should be in conformance with Recommendation ITU-R BT.1364.

3.6.3 Payload ID mapping

The payload identifier should be mapped into the blanking area of each basic stream of 10G-HDSDI. Table 1-4 defines the payload identifier for the UHDTV1 video payload.

This payload identifier should be in conformance with the payload identifier format defined in Recommendation ITU-R BT.1614. The byte 1 value of $A1_h$ is mandatory and identifies the video payload format as UHDTV1. The remaining 3 bytes values specify the other features of the video payload for UHDTV1 as defined in Part 1 of this Recommendation.

The location of this payload identifier should be in conformance with Annex B to Part 1.

TABLE 1-4

**Payload identifier definitions for UHD TV1 video payloads on a single-link
or a dual-link or a quad-link 10 Gbit/s (nominal) serial digital interface**

Bits	Byte 1	Byte 2	Byte 3	Byte 4
Bit 7	1	Interlaced (0) or progressive (1) transport	Reserved (0)	Channel assignment of Octa link
Bit 6	0	progressive (1) picture	Reserved (0)	CH1 (0 _h), CH2 (1 _h), CH3 (2 _h), CH4 (3 _h), CH5 (4 _h), CH (5 _h), CH7 (6 _h) or CH8 (7 _h)
Bit 5	1	Transfer characteristics SDR-TV (0 _h), HLG(1 _h), PQ (2 _h), unspecified (3 _h)	10G link assignment of Single/Dual/Quad link CH1 (0 _h), CH2(1 _h), CH3(2 _h) or CH4(3 _h)	Colour encoding Rec. ITU-R BT.709 ¹ = (0) or Rec. ITU-R BT.2020 = (1)
Bit 3	0	Picture Rate 0 _h = undefined, 1 _h = Reserved, 2 _h = 24/1.001 3 _h = 24, 5 _h = 25, 6 _h = 30/1.001, 7 _h = 30, 9 _h = 50,	Sampling structure 4:2:2 (Y'C _B C _R ' or IC _T C _P) = (0 _h),	Reserved (0)
Bit 2	0		4:4:4 (Y'C _B C _R ' or IC _T C _P) = (1 _h),	Luminance and colour difference signal NCL Y'C _B C _R ' (0), CL SDR Y'C _B C _R ' or IC _T C _P (1)
Bit 1	0	A _h = 60/1.001, B _h = 60, D _h = 100, E _h = 120/1.001, F _h = 120, Other values reserved.	4:4:4 (G'B'R') = (2 _h),	Bit depth 10-bit full range (0 _h), 10-bit narrow range (1 _h), 12-bit narrow range (2 _h), 12-bit full range (3 _h)
Bit 0	1		4:2:0 (Y'C _B C _R ' or IC _T C _P) = (3 _h), Other values reserved	

When identifying UHD TV1 video payloads mapped onto a single-link, a dual-link or a quad-link 10 Gbit/s serial digital interface, the following payload ID values should apply:

- interlace/progressive transport flag bit should be set to (0) or (1) according to the digital interface transport;
- interlaced/progressive picture flag bit should be set to (1);
- transfer characteristics should be identified by bits b5 and b4 of byte 2 having the following values:
 - (0_h) should identify SDR-TV,
 - (1_h) should identify HLG,
 - (2_h) should identify PQ,
 - (3_h) should identify unspecified,
- colour coding flag in bit 4 of byte 4 should be set to 1 to signify Recommendation ITU-R BT.2020 colorimetry;
- luminance and colour difference signal flag should be set to (0) for non-constant luminance Y'C_BC_R' and (1) for constant luminance SDR Y'C_BC_R' or HDR IC_TC_P;
- picture rate should be set to the value of the UHD TV1 payload;
- sampling structure should be set to the value of the payload being carried;

¹ Recommendation ITU-R BT.709 colorimetry is not permitted in this Recommendation.

- assignment order of the basic stream channels and the 10G links for the payload IDs should correspond to the numeric order of the 10 Gbit/s HDSDI input channel and link numbers as defined in §§ 3.2 and 3.3.

The 10G channel number in bit b4 and b5 of byte 3 should be set to a value of (0_h) in the case of a single-link or first link and to (1_h) for the second link in the case of a dual-link and (0_h) for the first link, (1_h) for the second link, (2_h) for the third link and (3_h) for the fourth link in the case of a quad-link.

The basic stream channel number in bit b5, b6 and b7 of byte 4 should be set to the following values:

- (0_h) should identify the first link;
- (1_h) should identify the second link;
- (2_h) should identify the third link;
- (3_h) should identify the fourth link;
- (4_h) should identify the fifth link;
- (5_h) should identify the sixth link;
- (6_h) should identify the seventh link;
- (7_h) should identify the eighth link.

The bit depth of the sample quantization should be identified by bits b0 and b1 of byte 4 having the following values:

- (0_h) should identify quantization using 10 bits per sample with the full range coding;
- (1_h) should identify quantization using 10 bits per sample with the narrow range coding;
- (2_h) should identify quantization using 12 bits per sample with the narrow range coding;
- (3_h) should identify quantization using 12 bits per sample with the full range coding.

4 UHDTV2 mapping into quad-link or octa-link or sixteen-link 10G-HDSDI

4.1 Video payload mapping

Table 1-5 shows the UHDTV2 image formats which should be divided into four UHDTV1 images and then should be further divided into 16 or 32 sub-images which have been defined in Annex A to Part 1 as System 1.1, 2.1, 2.2, 2.3, 2.4, 2.5, 4.1, 4.2 or 4.3 by 2-sample interleave division or 2-frame 2-sample interleave division. Therefore, this division of a UHDTV2 image generates 16 or 32 sub-images which have the 1 920 × 1 080 picture formats and should be mapped into the quad-link, the octa-link or the sixteen-link of 10G-HDSDI Mode D defined in Annex B to Part 1.

Figure 1-8 shows 2-sample interleave division of UHDTV2 image into four UHDTV1 images by 2-sample interleave division. Even lines of Systems U2.1 through U2.9 images should be divided into sub-UHDTV1 images 1 and 2 as per two consecutive horizontal samples, and odd lines should be divided into sub-UHDTV1 images 3 and 4 as per two consecutive horizontal samples.

The 0 components of the 4:2:0 (even-numbered samples on odd-numbered lines of unassigned C'_BC'_R) system image data should be assigned 200_h (512₍₁₀₎) in case of a 10-bit system and 800_h (2048₍₁₀₎) in case of a 12-bit system.

TABLE 1-5

Source image formats of UHDTV2 supported by Part 1 of this Recommendation

System Number	System nomenclature	Sampling Structure / Pixel Depth	Frame frequency Hz	Sub-image format defined in Annex A to Part 1
U2.1	7680 × 4320/24/P 7680 × 4320/25/P 7680 × 4320/30/P	4:2:0 or 4:2:2 (Y'C _B C _R)/10-bit	24, 25 and 30 Progressive	System 1.1
	7680 × 4320/23.98/P 7680 × 4320/29.97/P		24/1.001, 30/1.001 Progressive	
U2.2	7680 × 4320/24/P 7680 × 4320/25/P 7680 × 4320/30/P	4:4:4 (R'G'B')/10-bit	24, 25 and 30 Progressive	System 2.2
	7680 × 4320/23.98/P 7680 × 4320/29.97/P		24/1.001, 30/1.001 Progressive	
U2.3	7680 × 4320/24/P 7680 × 4320/25/P 7680 × 4320/30/P	4:4:4 (R'G'B')/12-bit	24, 25 and 30 Progressive	System 2.3
	7680 × 4320/23.98/P 7680 × 4320/29.97/P		24/1.001, 30/1.001 Progressive	
U2.4	7680 × 4320/24/P 7680 × 4320/25/P 7680 × 4320/30/P	4:4:4 (Y'C _B C _R)/10-bit	24, 25 and 30 Progressive	System 2.4
	7680 × 4320/23.98/P 7680 × 4320/29.97/P		24/1.001, 30/1.001 Progressive	
U2.5	7680 × 4320/24/P 7680 × 4320/25/P 7680 × 4320/30/P	4:2:0, 4:2:2 or 4:4:4 (Y'C _B C _R)/12-bit	24, 25 and 30 Progressive	System 2.5
	7680 × 4320/23.98/P 7680 × 4320/29.97/P		24/1.001, 30/1.001 Progressive	
U2.6	7680 × 4320/50/P 7680 × 4320/60/P	4:2:0 or 4:2:2 (Y'C _B C _R)/10-bit	50 and 60 Progressive	System 2.1
	7680 × 4320/59.94/P		60/1.001 Progressive	
U2.7	7680 × 4320/50/P 7680 × 4320/60/P	4:2:0 or 4:2:2 (Y'C _B C _R)/12-bit	50 and 60 Progressive	System 4.1
	7680 × 4320/59.94/P		60/1.001 Progressive	
U2.8	7680 × 4320/50/P 7680 × 4320/60/P	4:4:4 (R'G'B' or Y'C _B C _R)/10-bit	50 and 60 Progressive	System 4.2
	7680 × 4320/59.94/P		60/1.001 Progressive	
U2.9	7680 × 4320/50/P 7680 × 4320/60/P	4:4:4 (R'G'B' or Y'C _B C _R)/12-bit	50 and 60 Progressive	System 4.3
	7680 × 4320/59.94/P		60/1.001 Progressive	
U2.10	7680 × 4320/19.88/P	4:2:0 or 4:2:2 (Y'C _B C _R)/10-bit	120/1.001 Progressive	System 2.1
U2.10	7680 × 4320/120/P	4:2:0 or 4:2:2 (Y'C _B C _R)/10-bit	120 Progressive	System 2.1
U2.11	7680 × 4320/19.88/P	4:2:0 or 4:2:2 (Y'C _B C _R)/12-bit	120/1.001 Progressive	System 4.1
U2.11	7680 × 4320/120/P	4:2:0 or 4:2:2 (Y'C _B C _R)/12-bit	120 Progressive	System 4.1

TABLE 1-5 (*end*)

System Number	System nomenclature	Sampling Structure / Pixel Depth	Frame frequency Hz	Sub-image format defined in Annex A to Part 1
U2.12	7680 × 4320/19.88/P	4:4:4 (R'G'B' or Y'C _B C _R ')/10-bit	120/1.001 Progressive	System 4.2
U2.12	7680 × 4320/120/P	4:4:4 (R'G'B' or Y'C _B C _R ')/10-bit	120 Progressive	System 4.2
U2.13	7680 × 4320/19.88/P	4:4:4 (R'G'B' or Y'C _B C _R ')/12-bit	120/1.001 Progressive	System 4.3
U2.13	7680 × 4320/120/P	4:4:4 (R'G'B' or Y'C _B C _R ')/12-bit	120 Progressive	System 4.3
U2.14	7680 × 4320/100/P	4:2:0 or 4:2:2 (Y'C _B C _R ')/10-bit	100 Progressive	System 2.1
U2.15	7680 × 4320/100/P	4:2:0 or 4:2:2 (Y'C _B C _R ')/12-bit	100 Progressive	System 4.1
U2.16	7680 × 4320/100/P	4:4:4 (R'G'B' or Y'C _B C _R ')/10-bit	100 Progressive	System 4.2
U2.17	7680 × 4320/100/P	4:4:4 (R'G'B' or Y'C _B C _R ')/12-bit	100 Progressive	System 4.3

FIGURE 1-8

2-sample interleave division of UHDTV2 image into UHDTV1 images

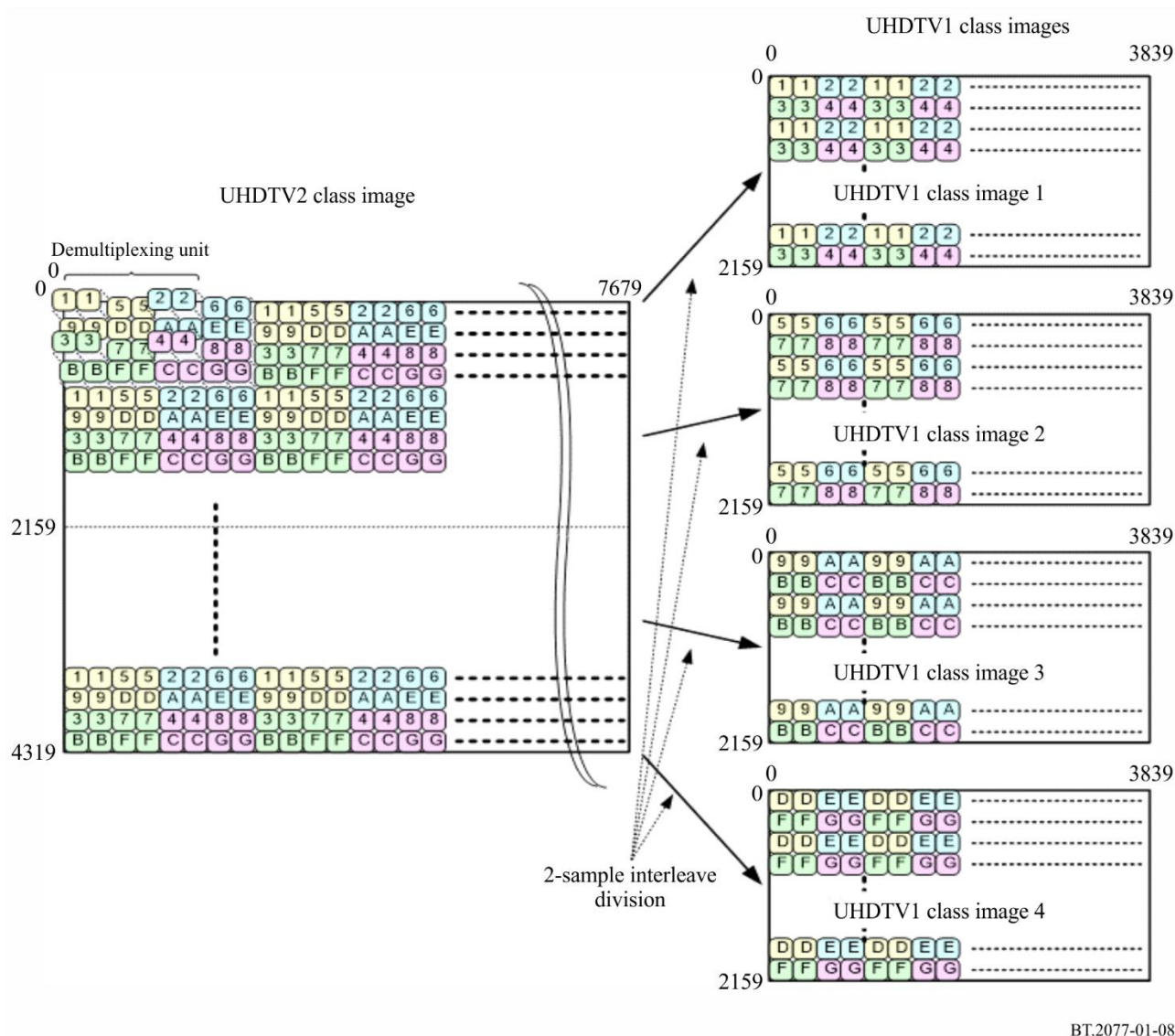

BT.2077-01-08

4.2 Quad-link 10G-HDSI for Systems U2.1 to U2.5

Four sub UHDTV1 images generated from System U2.1 should be mapped into quad-link 10G-HDSI. sub UHDTV1 image k is equivalent to System number 8.2 defined in § A1.4 of Annex A to Part 1 and should be mapped into CH1, CH3, CH5, CH7 (Link As) of 10G-HDSI Link k ; i.e.:

- UHDTV1 image 1 should be mapped into CH1, CH3, CH5 and CH7 (Link As) of 10G-HDSI Link 1;
- UHDTV1 image 2 should be mapped into CH1, CH3, CH5 and CH7 (Link As) of 10G-HDSI Link 2;
- UHDTV1 image 3 should be mapped into CH1, CH3, CH5 and CH7 (Link As) of 10G-HDSI Link 3;
- UHDTV1 image 4 should be mapped into CH1, CH3, CH5 and CH7 (Link As) of 10G-HDSI Link 4.

Four sub UHDTV1 images generated from Systems U2.2 to U2.5 should be mapped into quad-link 10G-HDSI. Sub UHDTV1 image k , where k is a number from 1 to 4, should be mapped into 10G-HDSI Link k in the same way as described in § B1.4 of Annex B to Part 1, i.e.:

- UHDTV1 image 1 should be mapped into CH1 through CH8 of 10G-HDSI Link 1;
- UHDTV1 image 2 should be mapped into CH1 through CH8 of 10G-HDSI Link 2;
- UHDTV1 image 3 should be mapped into CH1 through CH8 of 10G-HDSI Link 3;
- UHDTV1 image 4 should be mapped into CH1 through CH8 of 10G-HDSI Link 4.

4.3 Octa-link 10G-HDSI for Systems U2.6 to U2.9

Four sub UHDTV1 images generated from System U2.6 should be mapped into octa-link 10G-HDSI. Sub UHDTV1 image k , where k is a number from 1 to 4, should be mapped into CH1, CH3, CH5 and CH7 (Link As) of 10G-HDSI Link $(2k-1)$ and Link $(2k)$, i.e.:

- UHDTV1 image 1 should be mapped into CH1, CH3, CH5 and CH7 (Link As) of 10G-HDSI Link 1 and Link 2;
- UHDTV1 image 2 should be mapped into CH1, CH3, CH5 and CH7 (Link As) of 10G-HDSI Link 3 and Link 4;
- UHDTV1 image 3 should be mapped into CH1, CH3, CH5 and CH7 (Link As) of 10G-HDSI Link 5 and Link 6;
- UHDTV1 image 4 should be mapped into CH1, CH3, CH5 and CH7 (Link As) of 10G-HDSI Link 7 and Link 8.

Four sub UHDTV1 images generated from Systems U2.7, U2.8 and U2.9 should be mapped into octa-link 10G-HDSI. Sub UHDTV1 image k , where k is a number from 1 to 4, should be mapped into CH1, CH2, CH3, CH4, CH5, CH6, CH7 and CH8 of 10G-HDSI Link $(2k-1)$ and Link $(2k)$, i.e.:

- UHDTV1 image 1 should be mapped into CH1 through CH8 of 10G-HDSI Link 1 and Link 2;
- UHDTV1 image 2 should be mapped into CH1 through CH8 of 10G-HDSI Link 3 and Link 4;
- UHDTV1 image 3 should be mapped into CH1 through CH8 of 10G-HDSI Link 5 and Link 6;
- UHDTV1 image 4 should be mapped into CH1 through CH8 of 10G-HDSI Link 7 and Link 8.

4.4 Sixteen-link 10G-HDSI for Systems U2.10 to U2.17

Four sub UHDTV1 images generated from Systems U2.10 and U2.14 should be mapped into Sixteen-link 10G-HDSI. Sub UHDTV1 image k , where k is a number from 1 to 4, should be mapped into CH1, CH3, CH5 and CH7 (Link As) of 10G-HDSI Link $(4k-3)$, Link $(4k-2)$, Link $(4k-1)$ and Link $(4k)$, i.e.:

- UHDTV1 image 1 should be mapped into CH1, CH3, CH5 and CH7 (Link As) of 10G-HDSI Link 1, Link 2, Link 3 and Link 4;
- UHDTV1 image 2 should be mapped into CH1, CH3, CH5 and CH7 (Link As) of 10G-HDSI Link 5, Link 6, Link 7 and Link 8;
- UHDTV1 image 3 should be mapped into CH1, CH3, CH5 and CH7 (Link As) of 10G-HDSI Link 9, Link 10, Link 11 and Link 12;

- UHDTV1 image 4 should be mapped into CH1, CH3, CH5 and CH7 (Link As) of 10G-HDSI Link 13, Link 14, Link 15 and Link 16.

Four sub UHDTV1 images generated from Systems U2.11, U2.12 and U2.13, U2.15, U2.16, U2.17 should be mapped into sixteen-link 10G-HDSI. Sub UHDTV1 image k , where k is a number from 1 to 4, should be mapped into CH1, CH2, CH3, CH4, CH5, CH6, CH7 and CH8 of 10G-HDSI Link $(4k-3)$, Link $(4k-2)$, Link $(4k-3)$ and Link $(4k)$, i.e.:

- UHDTV1 image 1 should be mapped into CH1 through CH8 of 10G-HDSI Link 1, Link 2, Link 3 and Link 4;
- UHDTV1 image 2 should be mapped into CH1 through CH8 of 10G-HDSI Link 5, Link 6, Link 7 and Link 8;
- UHDTV1 image 3 should be mapped into CH1 through CH8 of 10G-HDSI Link 9, Link 10, Link 11 and Link 12;
- UHDTV1 image 4 should be mapped into CH1 through CH8 of 10G-HDSI Link 13, Link 14, Link 15 and Link 16.

4.5 Optical interface characteristics

The optical interface characteristics of the quad-link, the octa-link and the sixteen-link 10G-HDSI should be in conformance with Annex C to Part 1.

DWDM technology may be used for the transport of the quad-link, the octa-link or the sixteen-link 10G-HDSI. Table 1-6 defines the optical wavelengths of the 4ch, the 8ch and the 16ch DWDM interfaces. The approximate nominal central wavelengths of 1 557.36 nm, 1 556.55 nm, 1 555.75 nm and 1 554.94 nm should be assigned for the Link 1 through 4 for the 4ch DWDM interfaces, 1 557.36 nm, 1 556.55 nm, 1 555.75 nm, 1 554.94 nm, 1 554.13 nm, 1 553.33 nm, 1 552.52 nm and 1 551.72 nm should be assigned to the Link 1 through 8 for the 8ch DWDM interfaces and 1 557.36 nm, 1 556.55 nm, 1 555.75 nm, 1 554.94 nm, 1 554.13 nm, 1 553.33 nm, 1 552.52 nm, 1 551.72 nm, 1 550.92 nm, 1 550.12 nm, 1 549.32 nm, 1 548.51 nm, 1 547.72 nm, 1 546.92 nm, 1 546.12 nm and 1 545.32 nm should be assigned to the Link 1 through 16 for the 16ch DWDM interfaces in conformance with Annex C to Part 1.

TABLE 1-6

Nominal central wavelengths of 4ch and 8ch DWDM interfaces for UHDTV2

Link No.	Approximate nominal central wavelengths for 4ch DWDM	Approximate nominal central wavelengths for 8ch DWDM	Approximate nominal central wavelengths for 9-16ch DWDM
1	1 557.36 nm	1 557.36 nm	1 557.36 nm
2	1 556.55 nm	1 556.55 nm	1 556.55 nm
3	1 555.75 nm	1 555.75 nm	1 555.75 nm
4	1 554.94 nm	1 554.94 nm	1 554.94 nm
5		1 554.13 nm	1 554.13 nm
6		1 553.33 nm	1 553.33 nm
7		1 552.52 nm	1 552.52 nm
8		1 551.72 nm	1 551.72 nm
9			1 550.92 nm
10			1 550.12 nm

TABLE 1-6 (*end*)

Link No.	Approximate nominal central wavelengths for 4ch DWDM	Approximate nominal central wavelengths for 8ch DWDM	Approximate nominal central wavelengths for 9-16ch DWDM
11			1 549.32 nm
12			1 548.51 nm
13			1 547.72 nm
14			1 546.92 nm
15			1 546.12 nm
16			1 545.32 nm

4.6 ANC/audio data mapping

4.6.1 ANC data mapping

If present, optional ANC data should be mapped into the blanking area of each CH1 basic stream of 4 (or 8 or 16) 10G-HSDSI Links. The data format should be in conformance with Recommendation ITU-R BT.1364.

The ANC data should be mapped into CH1 basic stream of 10G-HSDSI Link 1 first, and any remaining data should be mapped into CH1 of 10G-HSDSI Link 2 through Link 4 (or Link 8 or Link 16) in ascending order.

4.6.2 Audio data mapping

When present, audio data should be mapped into the C'_B/C'_R data streams of the HANC data space in conformance with Recommendation ITU-R BT.1365 and should be mapped in the following order:

- (1st) CH1 basic stream of 10G-HSDSI Link 1, up to a maximum of 16 channels at a sampling frequency of 48 kHz or up to a maximum of 8 channels at a sampling frequency of 96 kHz;
- (2nd) CH1 basic stream of 10G-HSDSI Link 2, up to a maximum of 16 channels at a sampling frequency of 48 kHz or up to a maximum of 8 channels at a sampling frequency of 96 kHz;
- (3rd) CH1 basic stream of 10G-HSDSI Link 3, up to a maximum of 16 channels at a sampling frequency of 48 kHz or up to a maximum of 8 channels at a sampling frequency of 96 kHz;
- (4th) (or 8th in the case of octa-link or 16th in the case of sixteen-link) CH1 basic stream of 10G-HSDSI Link 4 (or 8 or 16), up to a maximum of 16 channels at a sampling frequency of 48 kHz or up to a maximum of 8 channels at a sampling frequency of 96 kHz.

Audio data should be mapped into the CH1 basic stream of 10G-HSDSI Link 1 first, up to its maximum transmission capacity of HANC data space, then into the CH1 basic stream of 10G-HSDSI Link 2, up to its maximum transmission capacity of HANC data space and so on. It should not be permitted to map audio data into the CH1 basic streams of 10G-HSDSI Link (n ; $n = 2 \sim 4$ (or 8 or 16)), if the CH1 basic stream of 10G-HSDSI Link ($n - 1$) is not filled up to its maximum transmission capacity.

The maximum channel number carried by quad-link 10G-HDSDI Mode D is 64 channels at a sampling frequency of 48 kHz or 32 channels at a sampling frequency of 96 kHz. The maximum channel number carried by octa-link and sixteen-link 10G-HDSDI is 128 channels and 256 channels at a sampling frequency of 48 kHz or 64 channels and 128 channels at a sampling frequency of 96 kHz.

NOTE – Mode D defined in Annex B to Part 1 can carry the HANC data included in CH1, 3, 5, 7 basic streams at frame frequencies from 23.98 Hz through 25 Hz. In Part 1 of this Recommendation the audio data is only mapped into the HANC data space of CH1 basic stream irrespective of frame frequency.

Audio control packets should be mapped into the Y' data streams of the HANC data space of CH1 of 10G-HDSDI Link 1 through Link 4 (or 8 or 16) (if necessary), and should be in conformance with Recommendation ITU-R BT.1365.

4.6.3 Payload ID mapping

The payload identifier should be mapped into the blanking area of each basic stream of 10G-HDSDI. Table 1-7 defines the payload identifier for the UHDTV2 video payload.

This payload identifier should be in conformance with the payload identifier format defined in Recommendation ITU-R BT.1614. The byte 1 value of A_{2h} is mandatory and identifies the video payload format as UHDTV2. The remaining 3 bytes values specify the other features of the video payload for UHDTV2 as defined in Part 1 of this Recommendation.

The location of this payload identifier should be in conformance with Annex B to Part 1.

TABLE 1-7

Payload identifier definitions for UHDTV2 video payloads on a quad-link, an octa-link or a sixteen-link 10 Gbit/s (nominal) serial digital interface

Bits	Byte 1	Byte 2	Byte 3	Byte 4
Bit 7	1	Interlaced (0) or progressive (1) transport	10G channel assignment of quad/octa/16 link CH1 (0 _h), CH2(1 _h) CH3 (2 _h), CH4 (3 _h), CH5 (4 _h), CH6 (5 _h), CH7 (6 _h), CH8 (7 _h) ... CH16(F _h)	Channel assignment of octa link CH1 (0 _h), CH2 (1 _h), CH3 (2 _h), CH4 (3 _h), CH5 (4 _h), CH6 (5 _h), CH7 (6 _h) or CH8 (7 _h)
Bit 6	0	Progressive (1) picture		Colour encoding Rec. ITU-R BT.709 ² (0) or Rec. ITU-R BT.2020 (1)
Bit 5	1	Transfer characteristics SDR-TV (0 _h), HLG (1 _h), PQ (2 _h), unspecified (3 _h)		
Bit 4	0			
Bit 3	0	Picture Rate 0 _h = undefined, 1 _h = Reserved, 2 _h = 24/1.001 3 _h = 24, 5 _h = 25, 6 _h = 30/1.001, 7 _h = 30, 9 _h = 50, A _h = 60/1.001, B _h = 60, D _h = 100, E _h = 120/1.001 F _h = 120, Other values reserved	Sampling structure 4:2:2 (Y'C' _B C' _R or IC _T C _P) = (0 _h), 4:4:4 (Y'C' _B C' _R or IC _T C _P) = (1 _h), 4:4:4 (G'B'R') = (2 _h), 4:2:0 (Y'C' _B C' _R or IC _T C _P) = (3 _h), Other values reserved	Reserved (0)
Bit 2	0		Luminance and colour difference signal NCL Y'C' _B C' _R (0), CL SDR Y'C' _B C' _R or HDR IC _T C _P (1)	
Bit 1	1		Bit depth 10-bit full range (0 _h), 10-bit narrow range (1 _h), 12-bit narrow range (2 _h), 12-bit full range (3 _h)	
Bit 0	0			

² Recommendation ITU-R BT.709 colorimetry is not permitted in this Recommendation.

When identifying UHDTV2 video payloads mapped onto a quad-link, an octa-link or a sixteen-link 10 Gbit/s serial digital interface, the following payload ID values should apply:

- interlace/progressive transport flag bit should be set to (0) or (1) according to the digital interface transport;
- interlaced/progressive picture flag bit should be set to (1);
- transfer characteristics should be identified by bits b5 and b4 of byte 2 having the following values:
 - (0_h) should identify SDR-TV,
 - (1_h) should identify HLG,
 - (2_h) should identify PQ,
 - (3_h) should identify unspecified,
- picture rate should be set to the value of the UHDTV2 video payload;
- The colour coding flag in bit 4 of byte 4 should be set to (1) to signify Recommendation ITU-R BT.2020 colorimetry;
- luminance and colour difference signal flag should be set to (0) for non-constant luminance Y'C_BC_R and (1) for constant luminance SDR Y'C_BC_R or HDR IC_{TC}P;
- sampling structure should be set to the value of the payload being carried;
- assignment order of the basic stream channels and the 10G links for the payload IDs should correspond to the order of the 10 Gbit/s HDSDI input channel and link numbers as defined in §§ 4.2 and 4.3.

For quad-link the 10G channel number in bit b4, b5, b6 and b7 of byte 3 should be set to the following values:

- (0_h) should identify the first link;
- (1_h) should identify the second link;
- (2_h) should identify the third link;
- (3_h) should identify the fourth link.

For octa-link the 10G channel number in bit b4, b5, b6 and b7 of byte 3 should be set to the following values:

- (0_h) should identify the first link;
- (1_h) should identify the second link;
- (2_h) should identify the third link;
- (3_h) should identify the fourth link;
- (4_h) should identify the fifth link;
- (5_h) should identify the sixth link;
- (6_h) should identify the seventh link;
- (7_h) should identify the eighth link.

The 10G channel number in bit b4, b5, b6 and b7 of byte 3 should be set to the following values in the case of a sixteen-link:

- (0_h) should identify the first link;
- (1_h) should identify the second link;
- (2_h) should identify the third link;

- (3_h) should identify the fourth link;
- (4_h) should identify the fifth link;
- (5_h) should identify the sixth link;
- (6_h) should identify the seventh link;
- (7_h) should identify the eighth link.
- (8_h) should identify the ninth link;
- (9_h) should identify the tenth link;
- (A_h) should identify the 11th link;
- (B_h) should identify the 12th link;
- (C_h) should identify the 13th link;
- (D_h) should identify the 14th link;
- (E_h) should identify the 15th link;
- (F_h) should identify the 16th link.

The basic stream channel number in bit b5, b6 and b7 of byte 4 should be set to the following values:

- (0_h) should identify the first link;
- (1_h) should identify the second link;
- (2_h) should identify the third link;
- (3_h) should identify the fourth link;
- (4_h) should identify the fifth link;
- (5_h) should identify the sixth link;
- (6_h) should identify the seventh link;
- (7_h) should identify the eighth link.

The bit depth of the sample quantization should be identified by bits b0 and b1 of byte 4 having the following values:

- (0_h) should identify quantization using 10 bits per sample with the full range coding
- (1_h) should identify quantization using 10 bits per sample with the narrow range coding;
- (2_h) should identify quantization using 12 bits per sample with the narrow range coding;
- (3_h) should identify quantization using 12 bits per sample with the full range coding.

**Annex A
to Part 1
(normative)**

10 Gbit/s UHDTV serial signal/data interface – basic stream derivation

System overview

The source data of the 10 Gbit/s data stream should be composed of multiple basic streams that each comply with the 1.5 Gbit/s HDSDI interleaved data stream defined in Recommendation ITU-R BT.1120. All container formats in Part 1 of this Recommendation are 1 920 × 1 080. Ancillary data mapping into a basic stream, should comply with Recommendation ITU-R BT.1364. Audio data, mapping should comply with Recommendation ITU-R BT.1365. Each 10-bit basic stream is packed into an 8-bit data block structure, which is then 8B/10B encoded. Multiple encoded blocks are multiplexed and serialized into a single 10 Gbit/s data stream in one of several modes as defined in Annex B to Part 1. The physical interface specification is defined in Annex C to Part 1.

The basic 1.5 Gbit/s stream structure is shown in Fig. 1-A1.

FIGURE 1-A1
Structure of 1.5 Gbit/s basic stream

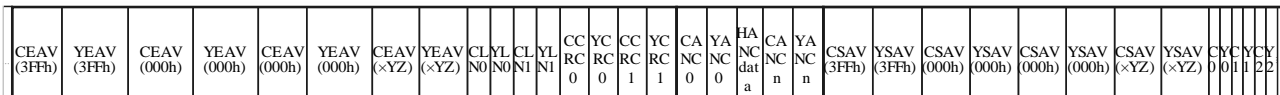

BT.2077-0 1-A01

A1 Source image formats

A1.1 Single-link 1.5 Gbit/s image formats

Table 1-A1 defines the image formats that should be mapped into one basic stream structure compliant with Recommendation ITU-R BT.1120. The interleaved stream derived from each image format should be assigned to a single basic stream defined in Part 1 of this Recommendation.

TABLE 1-A1
Single-link 1.5 Gbit/s source image format

System number	Signal format sampling structure/pixel depth	Frame frequency
1.1	4:2:2 (Y'C _B C _R)/10-bit	24, 25 and 30 Hz progressive, PsF
		23.98 and 29.97 Hz progressive, PsF

A1.2 Dual-link 1.5 Gbit/s image formats

Table 1-A2 defines the image formats that should be mapped into two basic streams. A source stream should be divided into two basic streams which have the same structure as dual link stream defined in Recommendation ITU-R BT.1120 § 4.5.

TABLE 1-A2

Dual-link 1.5 Gbit/s source image formats

System number	Signal format sampling structure/pixel depth	Frame/field frequency
2.1	4:2:2 (Y'C _B C _R)/10-bit	50 and 60 Hz progressive
		59.94 Hz progressive
		47.95 and 59.94 Hz progressive
2.2	4:4:4 (R'G'B'), 4:4:4:4 (R'G'B'+A)/10-bit	24, 25, and 30 Hz progressive, PsF
		23.98 and 29.97 Hz progressive, PsF
2.3	4:4:4 (R'G'B')/12-bit	24, 25 and 30 Hz progressive, PsF
		23.98 and 29.97 Hz progressive, PsF
2.4	4:4:4 (Y'C _B C _R)/10-bit, 4:4:4:4 (Y'C _B C _R +A)/10-bit	24, 25 and 30 Hz progressive, PsF
		23.98 and 29.97 Hz progressive, PsF
2.5	4:2:2 (Y'C _B C _R), 4:4:4 (Y'C _B C _R)/12-bit	24, 25 and 30 Hz progressive, PsF 50 and 60 Fields/s Interlace
		23.98 and 29.97 Hz progressive, PsF

A1.3 Quad-link 1.5 Gbit/s image formats

Table 1-A3 defines the image formats that should be mapped into four basic streams as defined in § A1.3.1.

TABLE 1-A3

Quad-link 1.5 Gbit/s source image formats

System number	Signal format sampling structure/pixel depth	Frame/field frequency
4.1	4:2:2 (Y'C _B C _R)/12-bit	50 and 60 Hz progressive
		59.94 Hz progressive
4.2	4:4:4 (R'G'B'), 4:4:4:4 (R'G'B'+A)/10-bit	50 and 60 Hz progressive
		59.94 Hz progressive
4.3	4:4:4 (R'G'B')/12-bit	50 and 60 Hz progressive
		59.94 Hz progressive

A1.3.1 Four way division of source data

A pair of frames as defined in Table 1-A3 should be divided and mapped into two sub-images equivalent to the System 2.2, 2.3 or System 2.5 image data using the line de-multiplexing method defined in § 4.5 of Recommendation ITU-R BT.1120. Each of these sub-images should be word de-multiplexed into two basic streams. In this Annex, sub-image should have the active digital sample structure as defined in Recommendation ITU-R BT.709.

Figure 1-A2 defines 4 way division of the System 4.1, 4.2 and 4.3 streams.

FIGURE 1-A2

Four way division for source stream of Systems 4.1, 4.2, and 4.3

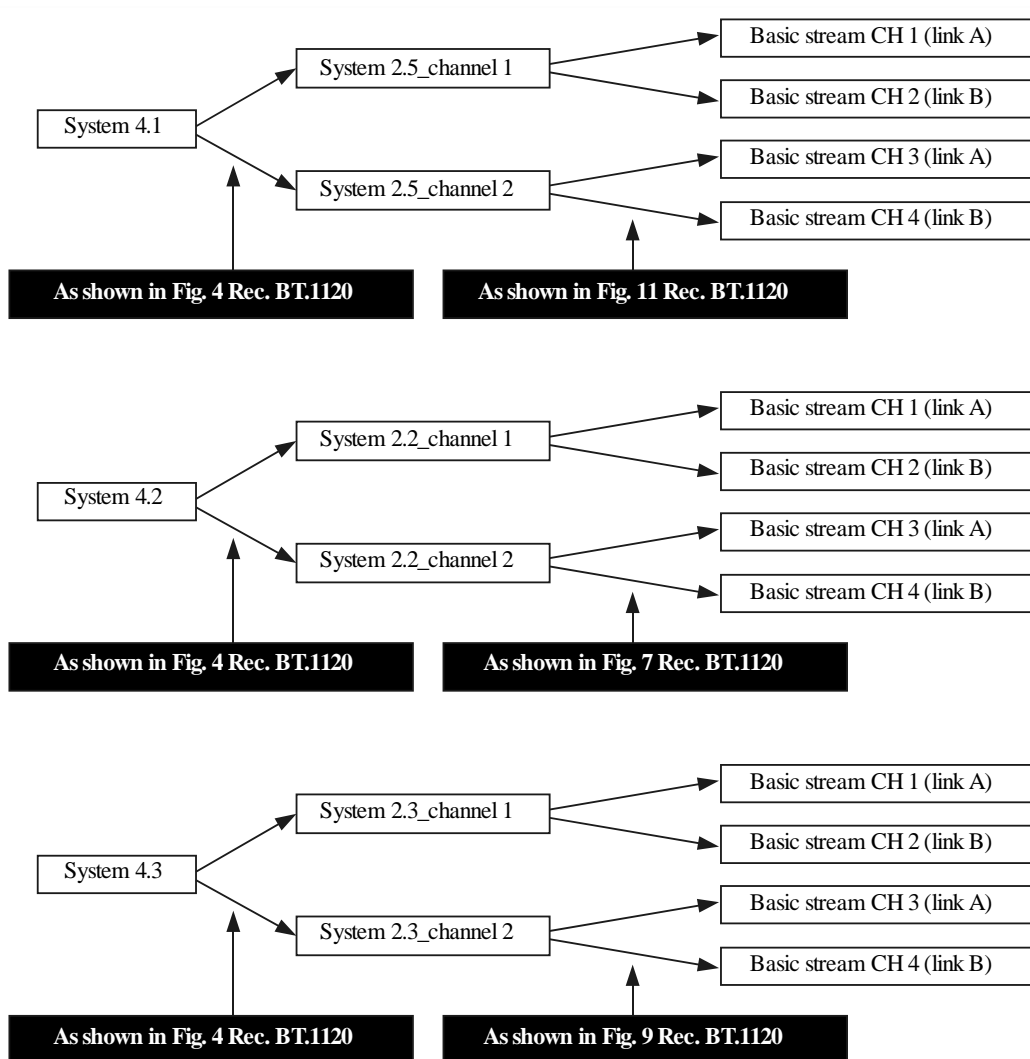

BT.2077-0 1-A02

A1.4 Octa-link 1.5 Gbit/s

Table 1-A4 lists the image formats that should be mapped into eight basic streams. Each of the 4K image formats listed in Table 1-A4 should be divided and mapped to the active area of four 2K sub-images by one of two methods and then each sub-image converted into two basic streams. The detail of the process is defined in § A1.4.1.

TABLE 1-A4
Octa-link 1.5 Gbit/s source image formats

System number	Picture format	Signal format sampling structure/pixel depth	Frame/field frequency
8.2	3 840 × 2 160	4:2:0 (Y'C _B C _R), 4:2:2 (Y'C _B C _R)/10-bit	24, 25 and 30 Hz progressive
			23.98 and 29.97 Hz progressive
8.3	3 840 × 2 160	4:4:4 (R'G'B')/10-bit	24, 25 and 30 Hz progressive
			23.98 and 29.97 Hz progressive
8.4	3 840 × 2 160	4:4:4 (Y'C _B C _R)/10-bit	24, 25 and 30 Hz progressive
			23.98 and 29.97 Hz progressive
8.5	3 840 × 2 160	4:2:0 (Y'C _B C _R), 4:2:2 (Y'C _B C _R)/12-bit	24, 25 and 30 Hz progressive
			23.98 and 29.97 Hz progressive
8.6	3 840 × 2 160	4:4:4 (R'G'B')/12-bit	24, 25 and 30 Hz progressive
			23.98 and 29.97 Hz progressive
8.7	3 840 × 2 160	4:4:4 (Y'C _B C _R)/12-bit	24, 25 and 30 Hz progressive
			23.98 and 29.97 Hz progressive

A1.4.1 Eight way division of source data

Figure 1-A3 shows sample structures of 4:4:4 (R'G'B') or (Y'C_BC_R), 4:2:2 (Y'C_BC_R) and 4:2:0 (Y'C_BC_R) systems for System 8.2 through 8.7 images defined in Recommendation ITU-R BT.2020. C_B' and C_R' signals should be horizontally sub-sampled by a factor of two in case of a 4:2:2 system and horizontally and vertically sub-sampled by a factor of two in case of a 4:2:0 system.

When transporting 4:2:0 system image data through a transport which has a 4:2:2 data structure, the 0 components of the 4:2:0 (even-numbered samples on odd-numbered lines of unassigned C_B'C_R') system image data should be assigned 200_h (512₍₁₀₎) in case of a 10-bit system and 800_h (2048₍₁₀₎) in case of a 12-bit system.

FIGURE 1-A3

Sample structures of 4:4:4 (R'G'B') or (Y' C_BC_R), 4:2:2 (Y'C_BC_R) and 4:2:0 (Y'C_BC_R) Systems

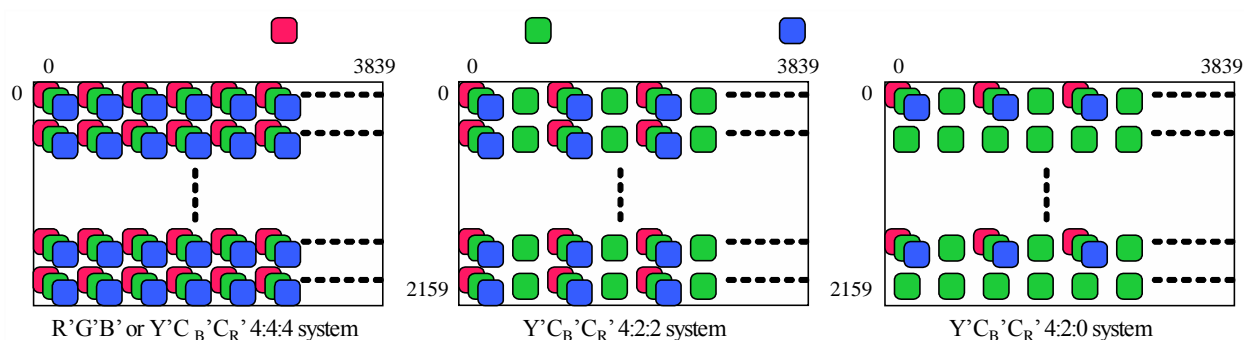

The active area of a 4K image of the systems listed in Table 1-A4 should be divided and mapped into the active area of four 2K sub-images equivalent to the System 1.1 or System 2.2 through System 2.5 image data.

Source image formats listed in Table 1-A4 should be mapped into four sub-images using either 2-sample interleave division as shown in Fig. 1-A4 or square division as shown in Fig. 1-A5. Figure 1-A3 illustrates how each four sub-images created by 2-sample interleave division has the same sampling structure 4:4:4 or 4:2:2.

Figure 1-A4 illustrates 2-sample interleave division at 30 Hz which requires less memory size and the signal processing delay is much less than that of the square division. Even lines of image formats listed in Table 1-A4 should be divided and mapped to the active area of sub-image 1 and 2 as per 2 consecutive horizontal samples and odd lines should be divided and mapped to the active area of sub-image 3 and 4 as per 2 consecutive horizontal samples. This division results in equivalent sub-image 1, 2, 3 and 4.

FIGURE 1-A4

2-sample interleave division to sub-image 1 through 4

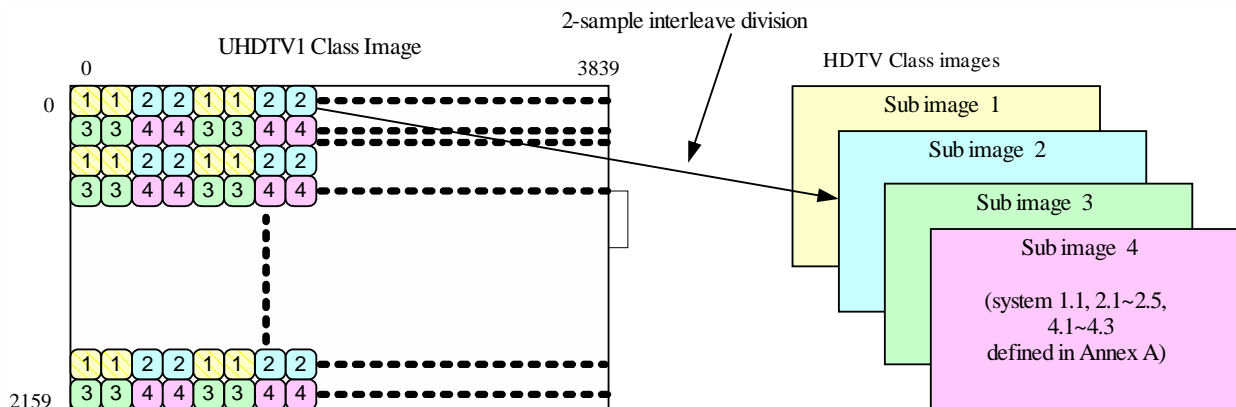

BT.2077-0 1-A04

Table 1-A5 defines the relation between sample/line (horizontal/vertical pixel) numbers of the original 3840×2160 image and sample/line numbers of the mapped 1920×1080 sub-image 1, 2, 3 and 4 of the 2-sample interleave division. Each sub-image should be divided and mapped into the active area as defined in Recommendation ITU-R BT.1120.

TABLE 1-A5

Relation between original image sample/line (horizontal/vertical pixel) and mapped sub-image sample/line of 2-sample interleave division

Sub-image	Original 3 840 × 2 160 Original 3 840 × 2 160	Mapped 1 920 × 1 080 sample number Mapped 1 920 × 1 080 line number
1	4M, 4M + 1 samples 2N line	2M, 2M + 1 samples 42 + N line
2	4M + 2, 4M + 3 samples 2N line	
3	4M, 4M + 1 samples 2N + 1 line	
4	4M + 2, 4M + 3 samples 2N + 1 line	

NOTE – M = 0, 1, 2, 3...959 or 1 023, N = 0, 1, 2, 3...1 079.

Figure 1-A5 defines the 4 way division (square division) at 24 Hz. The image formats listed in Table 1-A4 should be divided and mapped into the active area of four sub-images equivalent to the system 1.1 or 2.2 through 2.5 image data.

FIGURE 1-A5

4 way division (square division) to sub-image 1 through 4

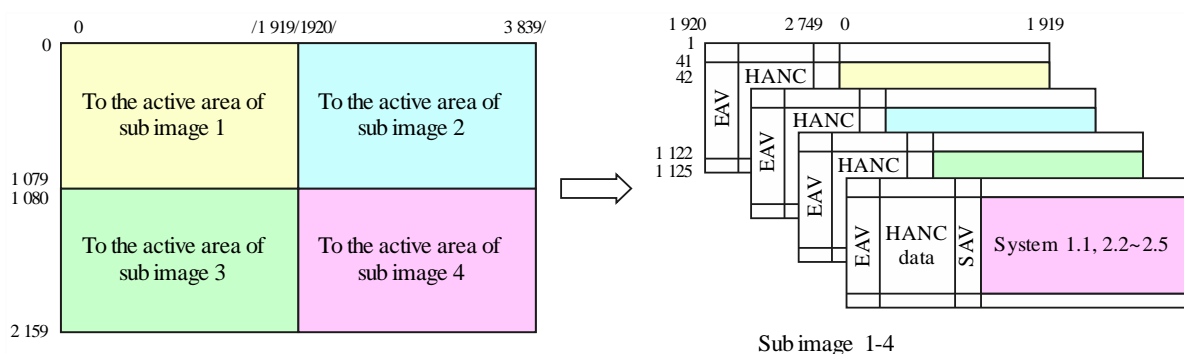

BT.2077-0 1-A05

Each sub-image created by the square division or the 2-sample interleave division should be virtually divided to the dual-link stream of the sub-image system number as shown in Table 1-A2. The digital stream derived from each link should be assigned to a basic stream defined in Part 1 of this Recommendation. Figure 1-A6 illustrates the division.

FIGURE 1-A6

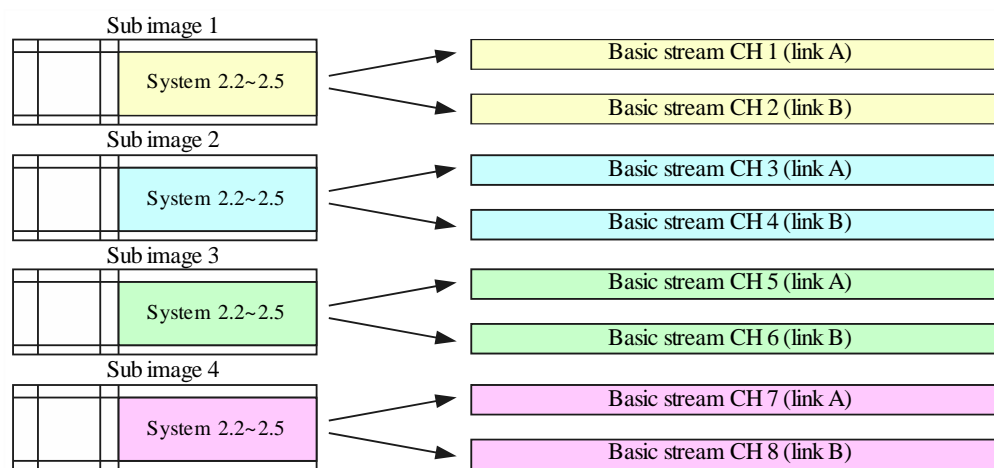
8 way division

BT.2077-0 1-A06

In the case of System 8.2 image ($3\ 840 \times 2\ 160$, 4:2:2 or 4:2:0/10-bit), sub-images 1 to 4 are equivalent to System number 1.1 and Link A should be assigned for the image transmission.

A2 Payload identifier

A payload identifier should be mapped into each basic stream in conformance with Recommendation ITU-R BT.1614.

A2.1 Payload identifier for 1.5 Gbit/s

The payload identifier for 1.5 Gbit/s should be in conformance with Recommendation ITU-R BT.1120.

A2.2 Payload identifier for dual-link 1.5 Gbit/s

The payload identifier for dual-link 1.5 Gbit/s should be in conformance with Recommendation ITU-R BT.1120.

A2.3 Payload identifier for quad-link 1.5 Gbit/s

When identifying 1 080-line video payloads mapped onto a quad-link 1.485 Gbit/s serial digital interface, the following limitations should apply (see Table 1-A6):

- Byte 1 should be set to 90_{h} ;
- The picture rate should only use the values permitted for quad-link interfaces in Part 1 of this Recommendation.

The sampling structure should be set to the value as defined in the payload ID

- Bit 6 of byte 3 should be used to identify 1 920 active Y'R'G'B' samples (0);
- the channel number in bit b6 and b7 of byte 4 should be set to a value of 0_{h} for the first link, to 1_{h} for the second link, to 2_{h} for the third link, and to 3_{h} for the fourth link;
- the bit depth should be identified by bits b0 and b1 of byte 4 having the following values:
 - 0_{h} reserved;

- 1_h should identify quantization using 10 bits per sample;
- 2_h should identify quantization using 12 bits per sample.

NOTE – In the case where the bit depth field indicates 12-bits per sample, these bits have been mapped into a 10-bit interface.

TABLE 1-A6

Payload identifier definitions for 1 080-line video payloads on a quad-link 1.485 Gbit/s (nominal) serial digital interface

Bits	Byte 1	Byte 2	Byte 3	Byte 4
Bit 7	1	Interlaced (0) or progressive (1) transport	Reserved (0)	Channel assignment CH1 (0_h), CH2 (1_h), CH3 (2_h) or CH4 (3_h)
Bit 6	0	Interlaced (0) or progressive (1) picture	Horizontal sampling 1 920 (0) Reserved (1)	
Bit 5	0	Transfer characteristics SDR-TV (0_h), HLG (1_h), PQ (2_h), unspecified (3_h)	Aspect Ratio 16:9 (1) Unknown (0)	Reserved (0)
Bit 4	1		Reserved (0)	Colour coding Rec. ITU-R BT.709 = (0) ³ , Rec. ITU-R BT.2020 = (1)
Bit 3	0	Picture Rate 0_h = undefined, 1_h = Reserved, 2_h = 24/1.001 3_h = 24, 5_h = 25, 6_h = 30/1.001, 7_h = 30, 9_h = 50, A_h = 60/1.001, B_h = 60, D_h = 100, E_h = 120/1.001, F_h = 120 Other values reserved.	Sampling structure 4:2:2 ($Y'C'_B C'_R$ or IC_{TCp}) = (0_h),	Luminance and colour difference signal NCL $Y'C'_B C'_R$ (0), CL SDR $Y'C'_B C'_R$ or HDR IC_{TCp} (1)
Bit 2	0			4:4:4 ($Y'C'_B C'_R$ or IC_{TCp}) = (1_h),
Bit 1	0		4:4:4 ($G'B'R'$) = (2_h), 4:2:0 ($Y'C'_B C'_R$ or IC_{TCp}) = (3_h)	
Bit 0	0			

A2.4 Payload identifier for octa-link 1.5 Gbit/s

When identifying 1 080-line video payloads mapped onto an octa-link 1.485 Gbit/s serial digital interface, the following limitations should apply (see Table 1-A7):

- byte 1 should be set to $A0_h$;
- the picture rate should only use the values as permitted for octa-link interfaces in § A1.4.

³ Recommendation ITU-R BT.709 colorimetry is not permitted in this Recommendation.

The sampling structure should be set to the value as defined in the payload ID. This should include the use of the alpha channel as a carrier of data as well as video.

- bit 6 of byte 3 should be used to identify 1920 active Y'/R'G'B' samples (0);
- the channel number in bit b5, b6 and b7 of byte 4 should be set to the following values:
 - (0_h) should identify the first link;
 - (1_h) should identify the second link;
 - (2_h) should identify the third link;
 - (3_h) should identify the fourth link;
 - (4_h) should identify the fifth link;
 - (5_h) should identify the sixth link;
 - (6_h) should identify the seventh link;
 - (7_h) should identify the eighth link.
- The bit depth should be identified by bits b0 and b1 of byte 4 having the following values:
 - (0_h) should identify quantization using 10 bits per sample with the full range coding;
 - (1_h) should identify quantization using 10 bits per sample with the narrow range coding;
 - (2_h) should identify quantization using 12 bits per sample with the narrow range coding;
 - (3_h) should identify quantization using 12 bits per sample with the full range coding.

NOTE – In the case where the bit depth field indicates 12-bits per sample, these bits have been mapped into a 10-bit interface.

TABLE 1-A7

Payload identifier definitions for 1 080-line video payloads on an octa-link 1.485 Gbit/s (nominal) serial digital interface

Bits	Byte 1	Byte 2	Byte 3	Byte 4
Bit 7	1	Interlaced (0) or progressive (1) transport	Reserved (0)	Channel assignment CH1 (0 _h), CH2 (1 _h), CH3 (2 _h), CH4 (3 _h), CH5 (4 _h), CH6 (5 _h), CH7 (6 _h) or CH8 (7 _h)
Bit 6	0	Interlaced (0) or progressive (1) picture	Horizontal sampling 1 920 (0) or Reserved (1)	
Bit 5	1	Transfer characteristics SDR-TV (0 _h), HLG (1 _h), PQ (2 _h), unspecified (3 _h)	Aspect Ratio 16:9 (1) Unknown (0)	
Bit 4	0		Reserved (0)	Colour encoding Rec. ITU-R BT.709 = (0) ⁴ , Rec. ITU-R BT.2020 = (1)
Bit 3	0	Picture Rate 0 _h = undefined, 1 _h = Reserved, 2 _h = 24/1.001, 3 _h = 24, 5 _h = 25, 6 _h = 30/1.001, 7 _h = 30, 9 _h = 50, A _h = 60/1.001, B _h = 60, D _h = 100, E _h = 120/1.001 F _h = 120, Other values reserved.	Sampling structure 4:2:2 (Y'C _B C _R or IC _T C _P) = (0 _h), 4:2:2:4 (Y'/C _B /C _R /A or I/C _T /C _P /A) = (4 _h), 4:4:4:4 (Y'/C _B /C _R /A or I/C _T /C _P /A) = (5 _h), 4:4:4:4 (G'B'R/A) = (6 _h), 4:4:4 (Y'C _B C _R or IC _T C _P) = (1 _h), 4:2:2:4 (Y'/C _B /C _R /D or I/C _T /C _P /D) = (8 _h), 4:4:4:4 (Y'/C _B /C _R /D or I/C _T /C _P /D) = (9 _h), 4:4:4:4 (G'B'R/D) = (A _h), 4:4:4 (G'B'R') = (2 _h), 4:2:0 (Y'C _B C _R or IC _T C _P) = (3 _h),	Luminance and colour difference signal NCL Y'C _B C _R (0), CL SDR Y'C _B C _R or HDR IC _T C _P (1)
Bit 2	0		Reserved (0)	
Bit 1	0			
Bit 0	0			Bit depth 10-bit full range (0 _h), 10-bit narrow range (1 _h), 12-bit narrow range (2 _h), 12-bit full range (3 _h)

A2.5 Placement of payload identifier

The placement of the payload identifier for each basic stream of 10G-HDSDI should be immediately after the SAV in the lines defined in Recommendation ITU-R BT.1614.

⁴ Recommendation ITU-R BT.709 colorimetry is not permitted in this Recommendation.

**Annex B
to Part 1
(normative)**

10 Gbit/s Serial signal/data interface – basic stream data mapping

System overview

This Annex specifies the multiplexing schemes to map up to 8 basic streams defined by Annex A to Part 1 into the 10 Gbit/s serial interface. 100 Hz and 120 Hz frame mappings are fully described in Part 1. The mapping also supports transmission of the embedded audio, payload ID and other ancillary data defined in Recommendation ITU-R BT.1364 in the source stream.

Figure 1-B1 shows the overall block diagram of the 10.692 Gbit/s interface which can carry $3\ 840 \times 2\ 160/30P/4:4:4$.

The outline of the data mapping process should be as follows:

- the 10-bit basic streams should be packed into arrays of 8-bit words;
- the generated byte array should be channel coded as 8B/10B encoded data;
- the blocks of encoded data should be interleaved and serialized into the 10.692 Gbit/s serial stream.

HANC data in some of the basic streams are not interleaved into 10.692 Gbit/s stream in the case of mapping Mode B, C or D. Details are defined in §§ B1.2, B1.3 and B1.4.

Figure 1-B1 illustrates the signal processing involved at the TX and RX ends of the transport. Default data values (040_h for Y' data and 200_h for C'_B/C'_R data) should be inserted into unused HANC data space of a basic stream if it has not been mapped onto the 10.692 Gbit/s stream.

FIGURE 1-B1

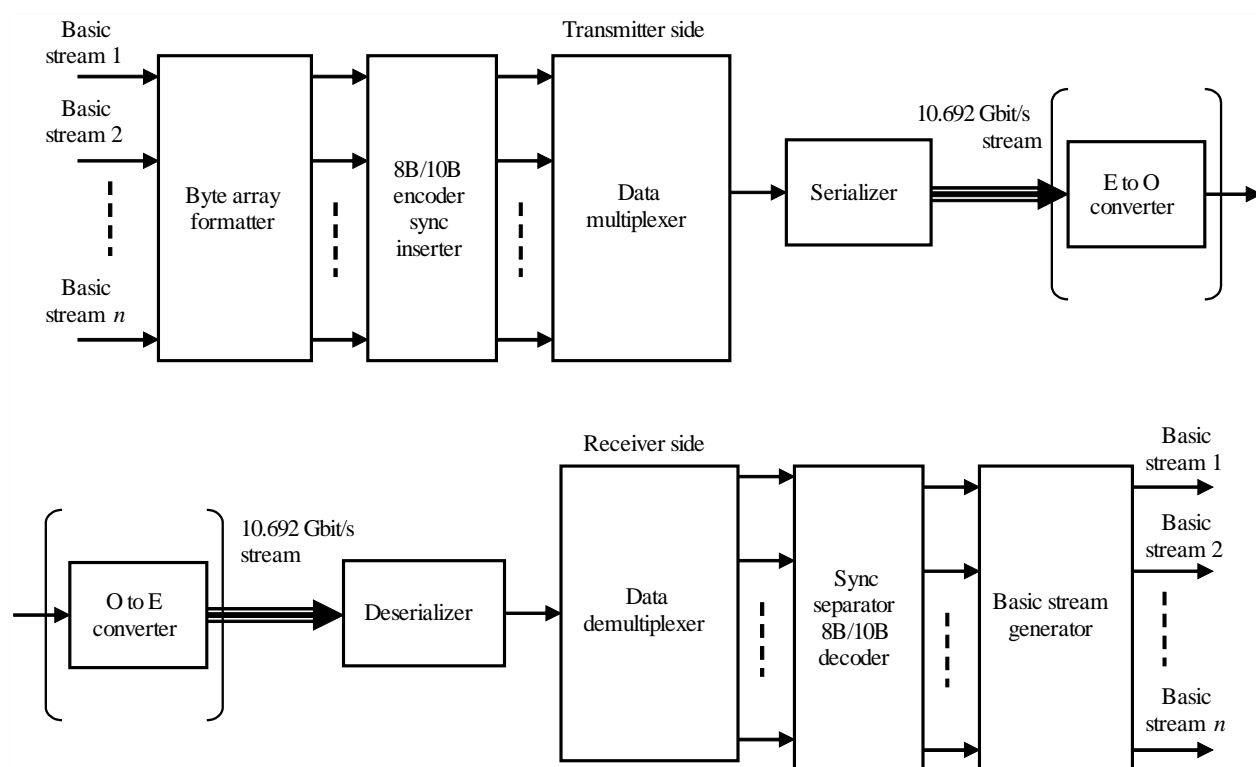
Overall block

BT.2077-0 1-B01

B1 Basic stream data mapping

This section defines four data mapping structures. Mode A and Mode B should be used for System 1.1 through System 4.3 images. Mode D should be used for System 8.2 through System 8.7 images, up to four pairs of System 2.2 through System 2.5 images or up to two pairs of System 4.1 through System 4.3 images. System numbers are defined in Annex A to Part 1.

Transmission of up to five basic streams as defined in Annex A to Part 1 is possible in Mode A, up to six basic streams is possible in Mode B and up to eight basic streams is possible in Mode D. All basic streams that are mapped together onto a 10.692 Gbit/s stream should have the same frame frequency and the same number of horizontal samples per line.

The placement of the ANC data including the payload identifier as defined in Recommendation ITU-R BT.1614 in the basic streams should be immediately following SAV of the line(s) specified in Recommendation ITU-R BT.1120.

The word clock frequency of each basic stream, as defined by Annex A to Part 1 and, should be 148.5 MHz or 148.5/1.001 MHz. The word clock frequency should be locked to the serial clock frequency (10.692 GHz or 10.692/1.001 GHz).

B1.1 5-Channel Mode (Mode A)

Up to five basic streams may be embedded into the 10.692 Gbit/s stream using mapping Mode A. The mapping should maintain all the information included in each of the five basic streams.

The 8B/10B encoded 50-bit data block data from each basic stream should be multiplexed into a single stream by the 50-bit block interleaving. The detail of the 50-bit block packing is defined in § B1.1.1.

The CH1 basic stream data should always be present for encoder and decoder synchronization. Other channels, when not used for image data, should be filled with stuffing data set to 100_h.

Figure 1-B2 illustrates the basic concept of Mode A mapping.

FIGURE 1-B2

Basic stream interleaving for Mode A

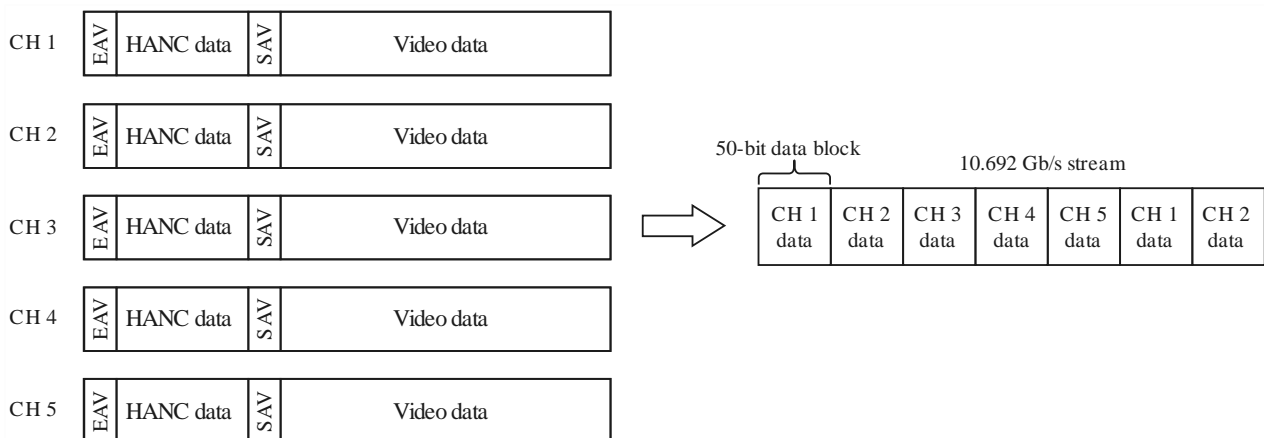

BT.2077-0 1-B02

B1.1.1 Mode A 50-Bit data blocking and 8B/10B encoding

Four-word (40-bit) data blocks of the source basic stream data starting from the first SAV data should be used for the blocking process.

Each 40-bit data block should be packed into five 8-bit words and then should be 8B/10B coded as defined in § 11 of ANSI INCITS 230. Consequently a 50-bit encoded data block should be generated from a 40-bit source data block. Figure 1-B3 defines the blocking process.

Encoding disparity in a 10.692 Gbit/s stream should be alternated at every 10-bit word. Initial value of negative disparity should be assigned to CH1 first SAV word of each line.

FIGURE 1-B3
Data alignment and 8B/10B encode process of 4-word data block

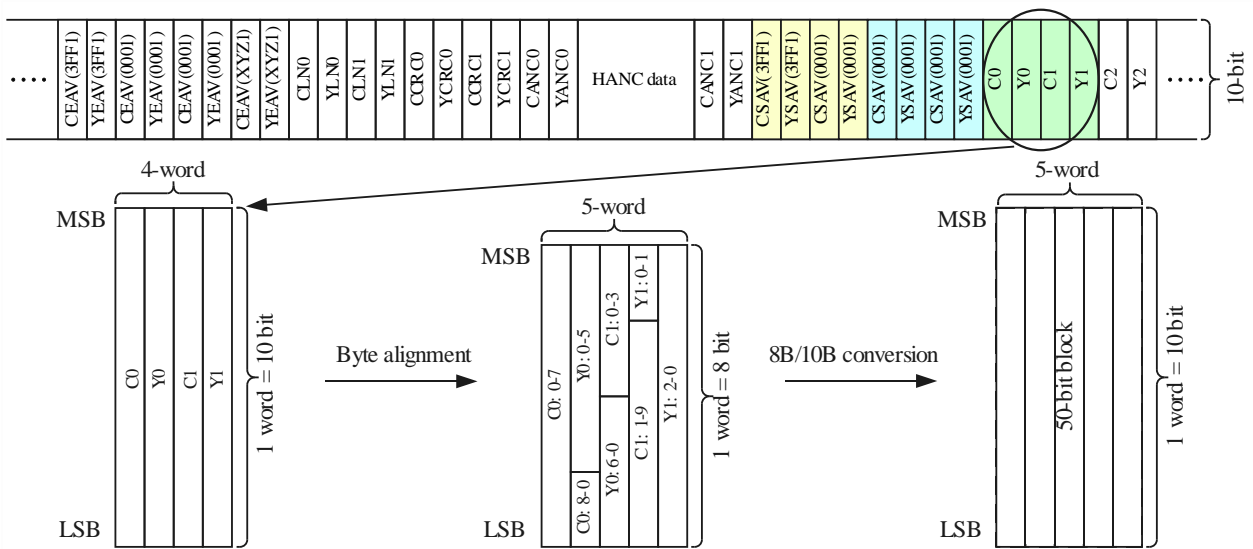

BT.2077-0 1-B03

B1.1.2 Data replacement of SAV part of CH1

In the CH1 basic stream, the first 40-bit byte aligned block at the beginning of each SAV should be replaced by a synchronization block. This process should be executed before 8B/10B encoding and should be as defined in Fig. 1-B4.

FIGURE 1-B4
SAV data replacement for CH1 data

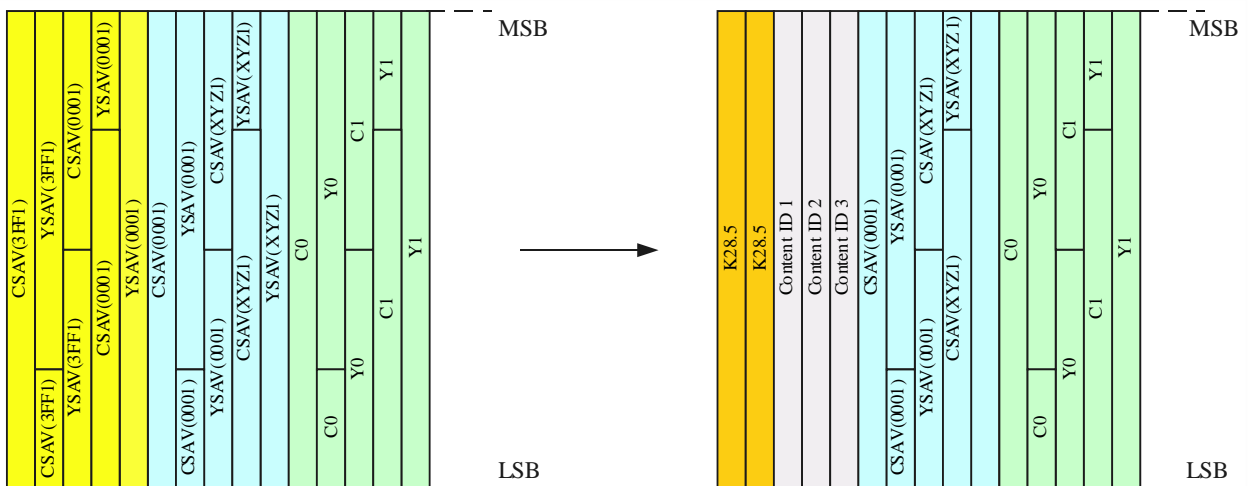

BT.2077-0 1-B04

The first 2 bytes of the byte aligned SAV data should be replaced with two K28.5 special characters defined in 8B/10B Code, and successive three words of the byte aligned SAV data should be replaced with the content ID bytes as defined in Table 1-B1.

Table 1-B1 defines the layout of content ID words.

Bit 7 of ID 1 should be set to 0 in the case of the “1 920 × 1 080 basic stream”, 1 is reserved.

Bits 5 and 6 of ID 1 should indicate the mapping structure and should be assigned as defined in Table 1-B3.

Bits 0 through 4 of ID1 should indicate the System number of CH1 basic stream and should be set as defined in Table 1-B2.

TABLE 1-B1

Content ID data arrangement for Mode A

Bit	7 (MSB)	6	5	4	3	2	1	0 (LSB)
ID 1	Basic stream	Mapping structure = 00		System ID				
ID 2	Reserved (00 _h)							
ID 3	Reserved (00 _h)							

MSB: Most significant bit

LSB: Least significant bit

TABLE 1-B2

System ID assignment

System ID	System number
00000	1.1
00001	1.2
00010 ~ 00011	Reserved
00100	2.1
00101	2.2
00110	2.3
00111	2.4
01000	2.5
01010	Reserved
01011 ~ 01111	Reserved
10000	4.1
10001	4.2
10010	4.3
10011 ~ 10101	Reserved
10110	8.2
10111	8.3
11000	8.4

TABLE 1-B2 (end)

11001	8.5
11010	Reserved
11011	8.7
11100 ~ 11111	Reserved

TABLE 1-B3

Mapping structure value

00: Mode A	01: Mode B	10: Reserved	11: Mode D
------------	------------	--------------	------------

B1.1.3 10.692 Gbit/s stream for Mode A transmission

The 50-bit encoded data block units from five source streams should be interleaved from CH1 through CH5 as shown in Fig. 1-B5. The stuffing data should be appended to the end of the HANC code blocks to adjust a line data period of Mode A to be consistent with a line period of a source stream. The data length in a line, and the number of stuffing data bytes in Mode A should be as shown in Table 1-A1 of Attachment A to Annex B to Part 1.

The interleaved stream should be serialized to 10.692 Gbit/s stream with LSB first order.

FIGURE 1-B5

Data alignment process for a total line

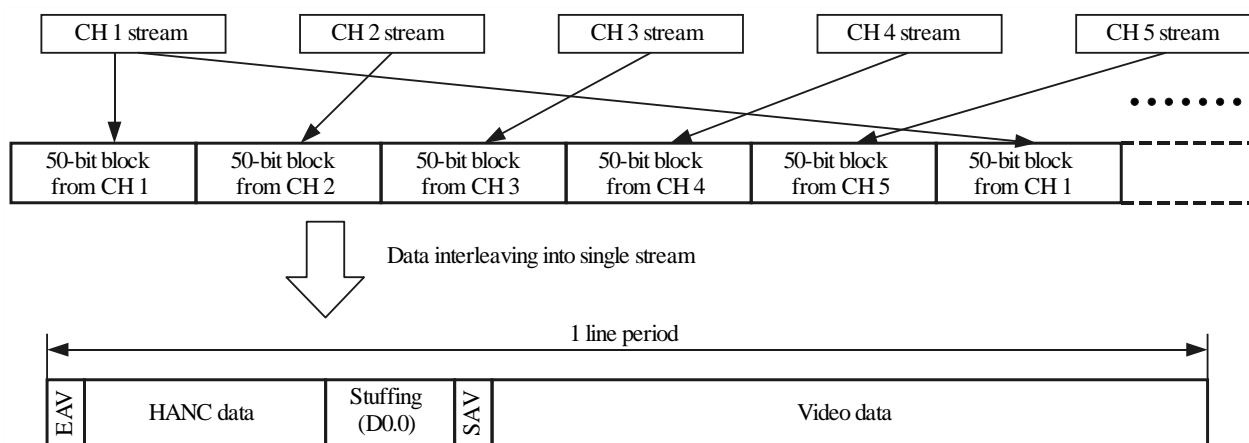

BT.2077-0 1-B05

B1.2 6-Channel Mode (Mode B)

Up to six basic streams may be embedded into the 10.692 Gbit/s stream using mapping Mode B.

The Mode B mapping should maintain all of the information included in CH1 to CH6 basic streams with the exception of HANC data in basic streams assigned to channel 5 and 6.

The CH1 basic stream should always be present for encoder and decoder synchronization. Other channels, where not used for image data, should be filled with stuffing data.

Figure 1-B6 illustrates the basic concept of Mode B mapping.

FIGURE 1-B6

Basic stream interleaving for Mode B

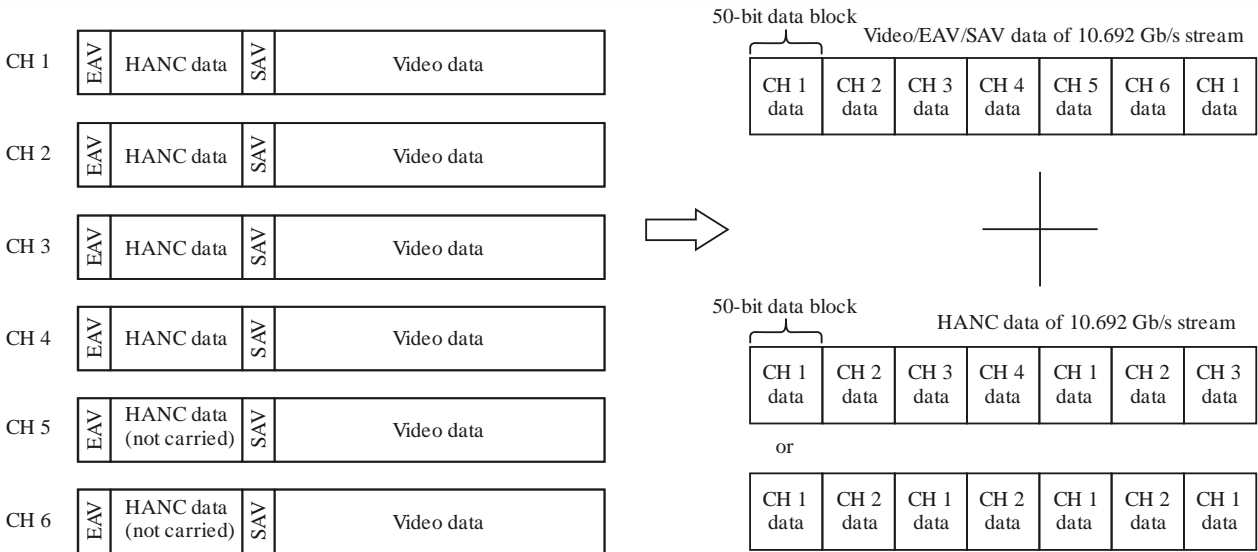

BT.2077-0 1-B06

B1.2.1 Mode B 50-bit data blocking and 8B/10B encoding

Four-word (40-bit) data block of the source stream starting from the first SAV data should be used for the blocking process.

Each four-word block should be packed into five 8-bit words and then should be encoded with 8B/10B coding as defined in § B1.1.1.

B1.2.2 Data replacement of SAV part of CH1

Data replacement of each SAV of the CH1 basic stream should be as defined in § B1.1.2.

Table 1-B4 specifies the layout of the content ID words for Mode B.

TABLE 1-B4

Content ID data arrangement for Mode B

Bit	7 (MSB)	6	5	4	3	2	1	0 (LSB)
ID 1	Basic stream	Mapping Structure = 01		System ID				
ID 2	Division	Reserved (0)						
ID 3	Reserved (00 _h)							

Bit 7 of ID 1 should be set using the same definitions as § B1.1.2 and ID 2 and ID 3 should be specific to Mode B.

Bit 7 of ID 2 should be set to 0 in the case of the “square division” and should be set to 1 in the case of the “2-sample interleave division”.

Bit 0 through bit 6 of ID 2 should be reserved and should be set to 0.

ID 3 should be reserved and should be set to 00_h.

B1.2.3 10.692 Gbit/s stream for Mode B transmission

Figure 1-B7 defines the stream structure of Mode B transmission. The mapping of this mode should carry all the video data included in CH1 to CH6 basic stream.

For a “1 920 × 1080 basic stream”, HANC data included in CH1 to CH4 at the frame frequencies of 23.98 Hz through 30 Hz should be 8B/10B encoded and embedded in the 10.692 Gbit/s stream with 50-bit blocking. Each 4-word HANC data block should be packed to five 8-bit words and then should be encoded with 8B/10B coding as the same way as defined in § B1.1.1. HANC data included in other channels should be discarded. All other data included in CH1 through CH6 should be embedded in the same way as Mode A transmission.

Stuffing data should be appended to the end of the HANC code blocks to adjust the line data period of Mode B to be consistent with the line period of source stream. The data length in a line and the number of stuffing bytes in Mode B should be as shown in Table 1-A2 of Attachment A to Annex B to Part 1.

The interleaved stream should be serialized into 10.692 Gbit/s stream with LSB first.

FIGURE 1-B7

Data alignment structure of Mode B stream

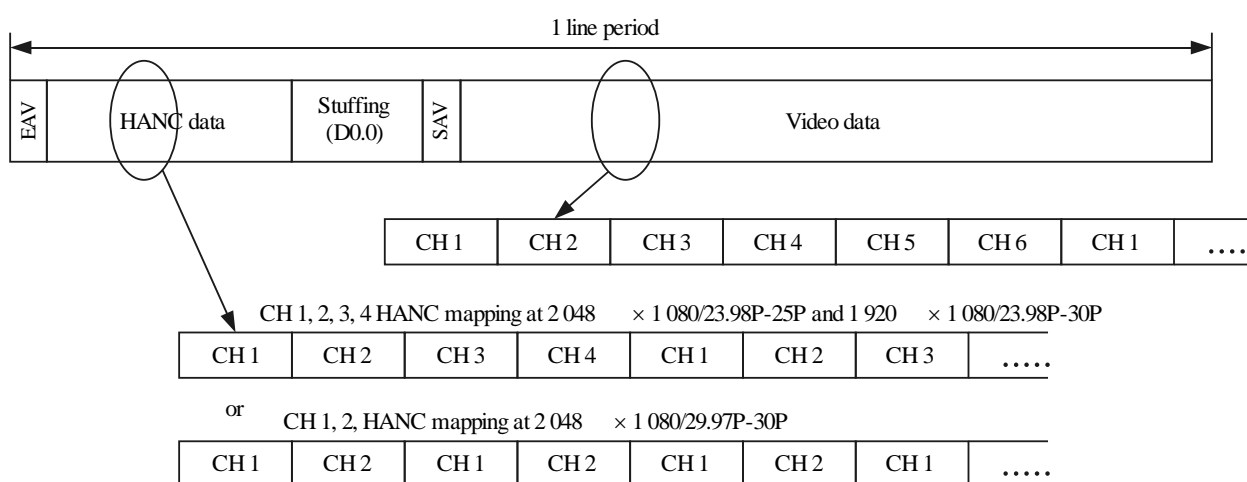

BT.2077-0 1-B07

B1.3 8-Channel Mode (Mode C)

Mode C is reserved and is not used in this Recommendation.

B1.4 8-Channel Mode (Mode D)

Up to eight basic streams may be embedded into the 10.692 Gbit/s stream using mapping Mode D. Mode D should be used for System 8.2 through System 8.7 images, up to four pairs of System 2.2 through System 2.6 images or up to two pairs of System 4.1 through System 4.3 images may be carried. The mapping for this mode should carry all the video data included in the CH1 to CH8 basic stream. Mode D also carries the HANC data included in CH1, CH3, CH5, CH7 of 1 920 × 1 080 basic

stream at frame frequencies of 23.98 Hz, 24 Hz and 25 Hz and CH1 of 1 920 × 1 080 basic stream at frame frequencies of 29.97 Hz and 30 Hz.

A pair of four word blocks from each of the odd and even basic stream derived from each sub-image should be combined to make an 80-bit block. The details of the 80-bit blocking is described in § B1.4.1. Blocking for CH1 or CH1, CH3, CH5, CH7 (Link As) HANC data space should be as defined in § B1.1.1.

The CH1 basic stream data should always be present for encoder and decoder synchronizing. Other channels, when not used for video data and HANC data, should be filled with stuffing data.

Figure 1-B8 illustrates the basic concept of Mode D mapping.

FIGURE 1-B8
Basic stream interleaving for Mode D

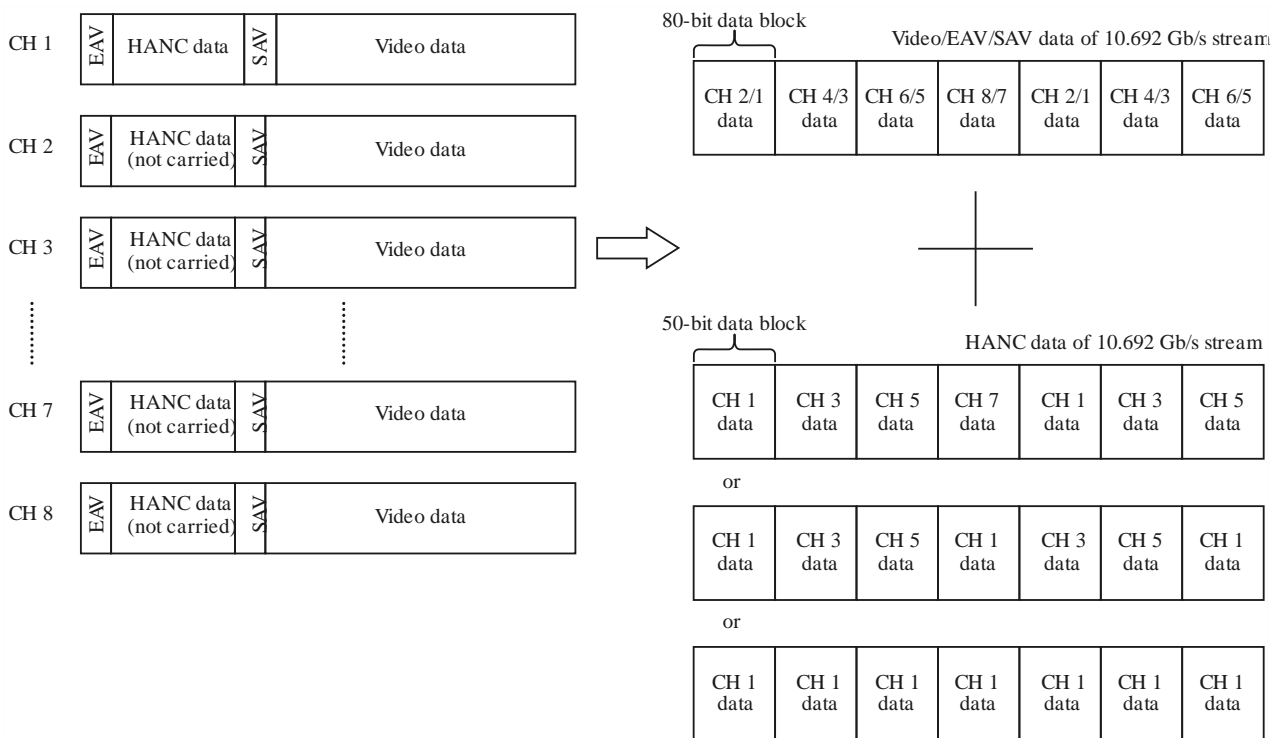

BT.2077-0 1-B08

B1.4.1 Mode D video data blocking, scrambling and 8B/10B encoding

Four-word (40-bit) data blocks of the source stream starting from the first SAV data should be used for the mapping operation. Figure 1-B9 illustrates the detail of the blocking process.

FIGURE 1-B9
80-bit blocking in Mode D

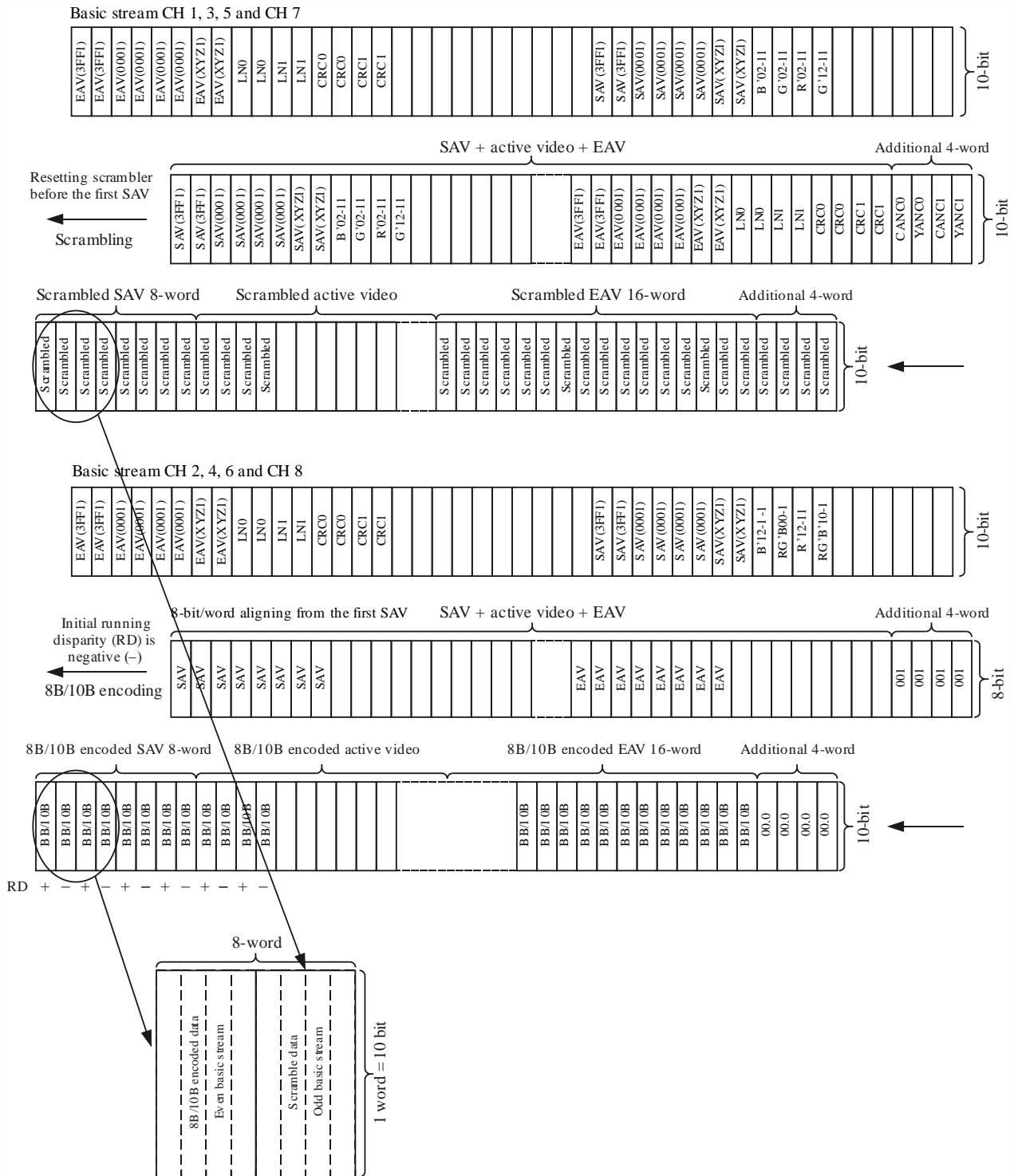

Each four-word block of each odd basic stream should be scrambled using the same scrambling polynomial as defined in Recommendation ITU-R BT.1120 with the initial value of the scrambler set to zero before the first SAV of each line. Bits b0 and b1 of $XYZ_h(C)$ in the SAV of CH1, CH3, CH5 and CH7 should be set to (0,0), (0,1), (1,0) and (1,1) respectively to randomize each scrambled data. The scrambled data starts from 1F5_h, which is the scrambled 3FF_h(C) and does not include initial register value of 0.

At the receiver side, de-scrambling should be performed with the initial value of the de-scrambler set to zero before the first SAV of each line. After descrambling, bits b0 and b1 of $XYZ_h(C)$ of the SAV should be set to (0,0).

For an even basic stream, bits b8 and b9 of the parity bits, and bits b0 and b1 of the reserved bits included in an alpha channel data block should be discarded before the blocking. The remaining 32-bit data from a 4-word block should be aligned to 4-byte length. Except in the case of LN and CRC values in an alpha channel, where the data blocking process defined in § B1.4.2 should be used.

The 4-byte block from an even basic stream should be 8B/10B encoded to make a 40-bit data block running disparity (RD) of the 8B/10B encoded data should alternate positive and negative from the first SAV.

A 40-bit 8B/10B encoded data block from an even basic stream and a 40-bit scrambled data block from an odd basic stream should be interleaved in the order of an even basic stream followed by an odd basic stream and should be combined to make an 80-bit block.

In the case of system 8.2 images, unused input CH for even basic streams (Link B) should not be used.

B1.4.2 Data blocking for CRC and LN area in an even basic stream

18-bits of CRC data in the alpha channel of an even basic stream should be aligned to three 6-bit areas within two 4-byte data blocks as illustrated in Fig. 1-B10 and as defined in § B1.3.2. The parity bit (b9) in CRC words should be discarded before blocking.

The lower 6 bits of word YCR0 should be aligned to follow after the CLN1 word. The higher 3 bits of word YCR0 and the lower 3 bits of word YCR1 should be aligned to follow after the CCR0 word. The higher 6 bits of word YCR1 should be aligned to follow after the CCR1 word.

These blocking processes should be used for 4-word blocking of CRC and LN values in an even basic stream.

FIGURE 1-B10
Blocking of CRC and LN word

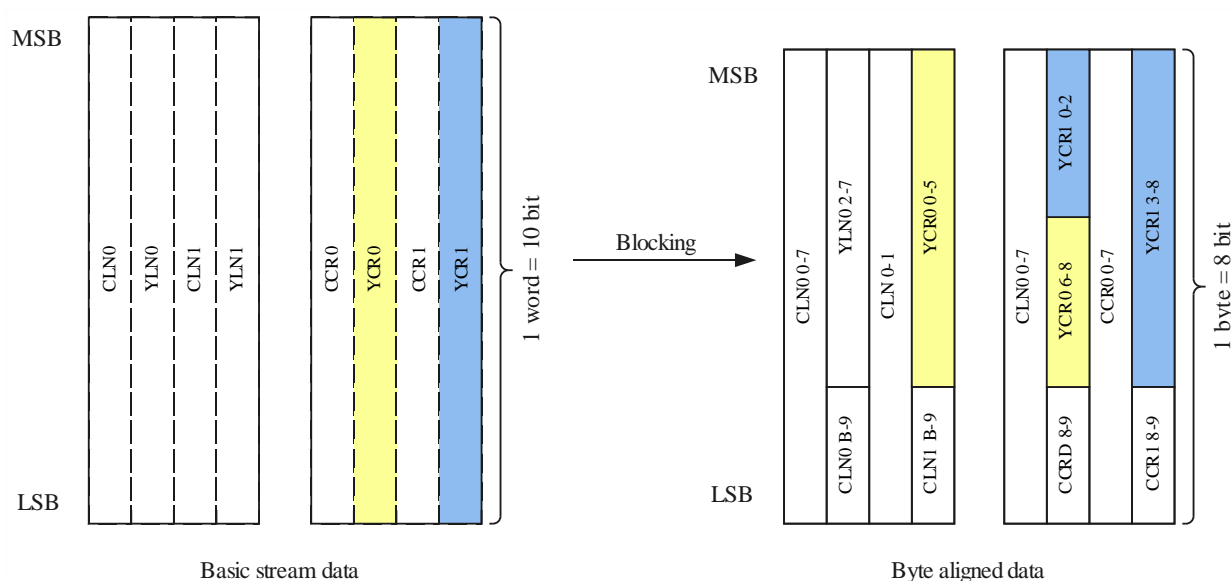

BT.2077-01-B10

B1.4.3 Data replacement of SAV Part of CH2

Data replacement of the synchronization word should be done on the byte aligned data at the beginning of the SAV of the CH2 basic stream in Mode D. This process should be executed before 8B/10B encoding.

The first two words of the SAV should be replaced with two K28.5 special characters defined in 8B/10B coding and successive two words of the byte aligned data should be replaced with content IDs. These processes are illustrated in Fig. 1-B11.

FIGURE 1-B11

SAV data replacement for CH2 data

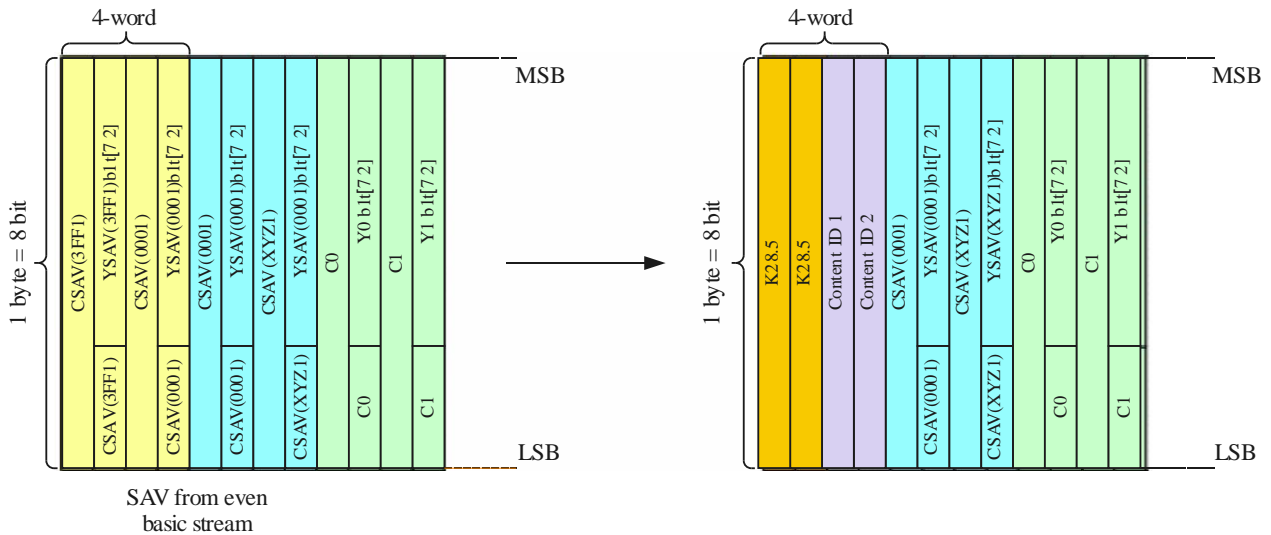

BT.2077-0 1-B11

Table 1-B5 specifies the layout of the content ID words for Mode D. ID 1 should be set using the same definitions as § B1.1.2 and ID 2 should be specific to Mode D. The System ID information should be a representation of the System number of the CH1 basic stream as defined in Table 1-B2.

TABLE 1-B5

Content ID data arrangement for Mode D

Bit	7 (MSB)	6	5	4	3	2	1	0 (LSB)
ID 1	Basic stream	Mapping structure = 11		System ID				
ID 2	Division	Reserved (0)						

Bit 7 of ID 1 should be set to 0 in the case of the “1 920 × 1 080 basic stream”.

Bit 7 of ID 2 should be set to 0 in the case of the “square division” and should be set to 1 in the case of the “2-sample interleave division”. The square division and the 2-sample interleave division is defined in Annex A to Part 1.

Bit 0 through bit 6 of ID2 should be reserved and should be set to 0.

B1.4.4 10.692 Gbit/s stream for Mode D transmission

Figure 1-B12 illustrates the stream structure of video data in Mode D transmission. Data from each sub-image should be interleaved with a unit of 80-bit Block.

FIGURE 1-B12
80-bit array interleaving derived from basic stream pair

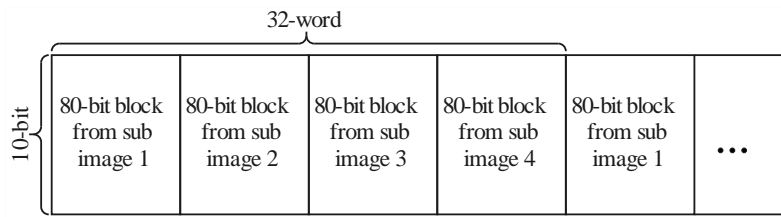

BT.2077-0 1-B12

Figure 1-B12 illustrates the stream structure of Mode D transmission.

In the case of $1\ 920 \times 1\ 080$ basic stream HANC data included in CH1, CH3, CH5 and CH7 at frame frequencies of 23.98 Hz, 24 Hz, 25 Hz, and HANC data in CH1 at frame frequencies of 29.97 Hz, 30 Hz should be 8B/10B encoded and embedded in the 10.692 Gbit/s stream with 50-bit blocking. HANC data included in other channels should be discarded. All other data included in CH1 to CH8 should be embedded with 80-bit block interleaving.

The interleaved stream should be serialized to 10.692 Gbit/s stream with LSB first. The data length in a line in Mode D should be as shown in Table 1-AB.3 of Attachment A to Annex B to Part 1.

FIGURE 1-B13
Data alignment structure of Mode D

CH 1, 3, 5 HANC mapping at $2\ 048 \times 1\ 080/23.98P-24P, 25P$

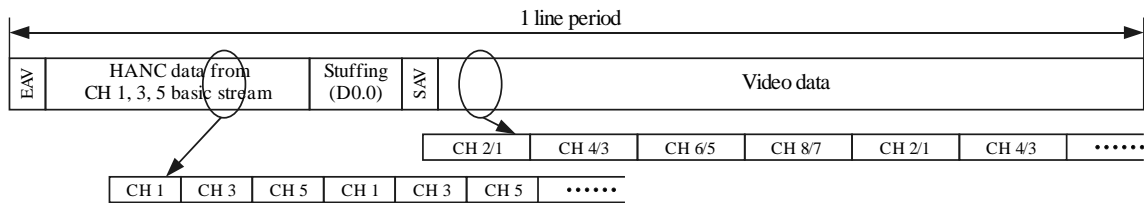

CH 1 HANC mapping at $1\ 920 \times 1\ 080/29.97P, 30P$

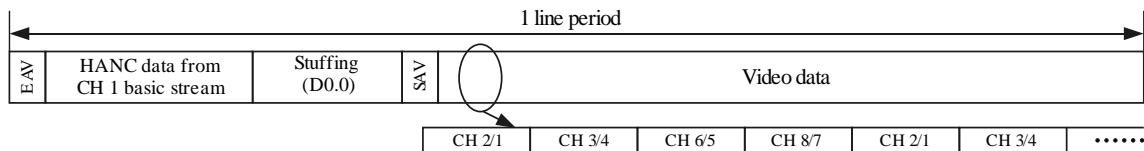

CH 1, 3, 5, 7 HANC mapping at $1\ 920 \times 1\ 080/23.98P, 24P, 25P$

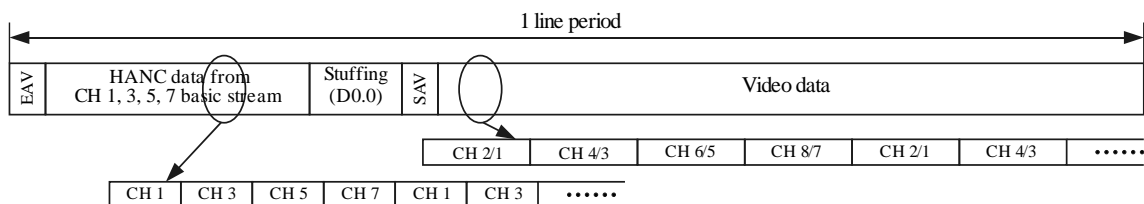

BT.2077-0 1-B13

Attachment A

to Annex B

to Part 1 (normative)

Data length in a line in Mode A, B and D

Data length in a line in Mode A, B, and D should be as shown in Tables 1-AB.1, 1-AB.2 and 1-AB.3 respectively.

TABLE 1-AB.1

Data length in a line (Mode A)

Basic stream	System No.	Frame frequency	Total word for a line	Video data	HANC and EAV/SAV data		Stuffing data
					CH 1, 2, 3, 4, 5		
1 920 × 1 080	1.1, 2.1, 2.2, 2.3, 2.4, 2.5, 4.1, 4.2, 4.3	23.98 Hz or 24 Hz	39 600	24 000	CH 1, 2, 3, 4, 5	10 375	5 225
		25 Hz or 50 Hz	38 016	24 000	CH 1, 2, 3, 4, 5	9 000	5 016
		29.97 Hz, 30 Hz 59.94 Hz or 60 Hz	31 680	24 000	CH 1, 2, 3, 4, 5	3 500	4 180

TABLE 1-AB.2

Data length in a line (Mode B)

Basic stream	System No.	Frame frequency	Total word for a line	Video data	HANC and EAV/SAV data		Stuffing data
					CH 1, 2, 3, 4		
1 920 × 1 080	1.1, 2.1, 2.2, 2.3, 2.4, 2.5, 4.1, 4.2, 4.3	23.98 Hz or 24 Hz	39 600	28 800	CH 1, 2, 3, 4	8 360	2 440
		25 Hz or 50 Hz	38 016	28 800	CH 1, 2, 3, 4	7 260	1 956
		29.97 Hz, 30 Hz 59.94 Hz or 60 Hz	31 680	28 800	CH 1, 2, 3, 4	2 860	20

TABLE 1-AB.3

Data length in a line (Mode D)

Basic stream	System number	Frame frequency	Total word for a line	Video data	HANC and EAV/SAV data		Stuffing data
					CH 1, 3, 5, 7		
1 920 × 1 080	8.2, 8.3, 8.4, 8.5, 8.7	23.98 Hz or 24 Hz	39 600	30 720	CH 1, 3, 5, 7	8 372	508
		25 Hz	38 016	30 720	CH 1, 3, 5, 7	7 272	24
		29.97 Hz or 30 Hz	31 680	30 720	CH1	862	98

Attachment B

to Annex B

to Part 1

(informative)

Channel assignment of the basic streams

Tables 1-BB.1, 1-BB.2, 1-BB.3 and 1-BB.4 show examples of the channel assignment of the 10.692 Gbit/s interface.

CH1 is used as the reference channel in all channel assignment schemes.

BB.1 Mode A channel assignment examples

Mode A is used to transmit up to five channels of 1.5 Gbit/s data streams, up to two pairs of the dual link 1.5 Gbit/s data streams, the quad link 1.5 Gbit/s data stream or the combination of these as long as the total number of input channels are not greater than five. Table 1-BB.1 shows assignment examples.

TABLE 1-BB.1

Channel assignment examples for Mode A

1 920 × 1 080 basic stream				
CH1	CH2	CH3	CH4	CH5
System 1.1 1 920/24/P	System 1.1 1 920/24/P	System 1.1 1 920/24/P	System 1.1 1 920/24/P	System 1.1 1 920/24/P
System 2.1 1 920/50/P, Link (basic stream) A, B		System 2.1 1 920/50/P, Link (basic stream) A, B		System 1.1 1 920/25/P
System 2.1 1 920/50/P, Link (basic stream) A, B		System 1.1 1 920/50/I	System 1.1 1 920/25/P	System 1.1 1 920/25/P
System 2.1, 2.2, 2.3, 2.4, 2.5 1 920/24/P, Link (basic stream) A, B		System 2.1, 2.2, 2.3, 2.4, 2.5 1 920/24/P, Link (basic stream) A, B		System 1.1 1 920/24/P or none
System 1.1 1 920/24/P	System 1.1 1 920/24/P	System 1.1 1 920/24/P	System 2.1, 2.2, 2.3, 2.4, 2.5 or 2.6 1 920/24/P, Link (basic stream) A, B	
System 4.1, 4.2 or 4.3 1 920/50/P, basic stream A, B, D				System 1.1 1 920/25/P

NOTE 1 – Frame frequencies shown in this Table are the lowest case of each image system. Other frame frequencies can also be applicable so far as the image format allows.

NOTE 2 – Use of shaded area is optional.

BB.2 Mode B channel assignment examples

Mode B is used to transmit up to six channels of the 1.5 Gbit/s data streams, up to three pairs of the dual-link 1.5 Gbit/s data streams, the quad-link 1.5 Gbit/s or the combination of these as long as the total number of input channels is not greater than six. Table 1-BB.2 shows the assignment examples.

TABLE 1-BB.2

Channel assignment examples for Mode B

1 920 × 1 080 basic stream					
CH1	CH2	CH3	CH4	CH5	CH6
System 1.1 1 920/24/P	System 1.1 1 920/24/P	System 1.1 1 920/24/P	System 1.1 1 920/24/P	System 1.1 1 920/24/P	System 1.1 1 920/24/P
System 2.1, 2.2, 2.3, 2.4 or 2.5 1 920/24/P, Link (basic stream) A, B		System 2.1, 2.2, 2.3, 2.4 or 2.5 1 920/24/P, Link (basic stream) A, B		System 2.1, 2.2, 2.3, 2.4 or 2.5 1 920/24/P, Link (basic stream) A, B	
System 4.1, 4.2 or 4.3 1 920/50/P, basic stream A, B, D				System 2.1, 2.2, 2.3, 2.4 or 2.5 1 920/25/P Link (basic stream) A, B	

NOTE 1 – HANC data included in CH5 and CH6 are discarded.

NOTE 2 – Frame frequencies shown in this Table are the lowest case of each image system. Other frame frequencies can also be applicable so far as the image format allows.

NOTE 3 – Use of shaded area is optional.

BB.3 Mode D channel assignment examples

Mode D for the System 8.2 through 8.7 octa-link 1 920 × 1 080 basic streams at frame frequencies from 23.98 Hz to 30 Hz.

Mode D is also used to transmit up quad link 1 920 × 1 080 basic streams at frame frequencies from 50 Hz to 60 Hz or the combination of these as long as the total number of input channels are not greater than eight.

Table 1-BB.3 shows the assignment examples.

TABLE 1-BB.3

Channel assignment for Mode D

1 920 × 1 080 basic stream							
CH1	CH2	CH3	CH4	CH5	CH6	CH7	CH8
System 8.2, 8.3, 8.5, or 8.7 3840/24/P, basic stream CH 1, 2, 3, 4, 5, 6, 7 and 8							
System 2.2, 2.3, 2.4 or 2.5 1 920/24/P, Link (basic stream) A, B	System 2.2, 2.3, 2.4 or 2.5 1 920/24/P, Link (basic stream) A, B		System 2.2, 2.3, 2.4 or 2.5 1 920/24/P, Link (basic stream) A, B		System 2.2, 2.3, 2.4 or 2.5 1 920/24/P, Link (basic stream) A, B		
System 4.1, 4.2 or 4.3 1 920/50/P, basic stream A, B, C, D				System 2.2, 2.3, 2.4 or 2.5 1 920/24/P, Link (basic stream) A, B		System 2.2, 2.3, 2.4 or 2.5 1 920/24/P, Link (basic stream) A, B	
System 4.1, 4.2 or 4.3 1 920/50/P, basic stream A, B, C, D				System 4.1, 4.2 or 4.3 1 920/50/P, basic stream A, B, C, D			

NOTE 1 – HANC data included in CH2 to CH8 at frame frequencies of 29.97 Hz and 30 Hz and HANC data included in CH2, CH4, CH6 and CH8 at frame frequencies of 23.98 Hz, 24 Hz and 25 Hz are discarded.

NOTE 2 – Frame frequencies shown in this Table are the lowest case of each image system. Other frame frequencies also can be applicable so far as the image format allows.

NOTE 3 – Use of shaded area is optional.

Annex C
to Part 1
(normative)

10 Gbit/s serial signal/data interface – optical fibre interface

Overview

The interface specification defined in this Annex applies to implementations covering a distance up to 2 km using single-mode fibre.

C1 Serial fibre interface optical and electrical specifications

The interface consists of one transmitter and one receiver in a point-to-point connection.

C1.1 The optical transmitter characteristics at nominal wavelengths of 1310 nm and 1550 nm should be as defined in Table 1-C1

The optical transmitter characteristics for DWDM at the nominal wavelength of 1550 nm should be as specified in Table 1-C1. The spectral grids for DWDM applications should be in conformance with 100 GHz and above defined in Recommendation ITU-T G.694.1.

The eye pattern should be measured with respect to the mask of the eye using a receiver with a fourth-order Bessel-Thomson response with a 3 dB frequency of $0.75 \times 10.692 \text{ GHz} = 8 \text{ GHz}$.

TABLE 1-C1

Optical transmitter characteristics

Nominal wavelength	1310 nm	1550 nm	1550 nm DWDM applications
Optical wavelength	1260 nm to 1355 nm	1530 nm to 1565 nm	1530 nm to 1565 nm
Wavelength accuracy	NA (not applicable)	NA	-100 pm to +100 pm
-20 dB spectral width (max)	1 nm	1 nm	1 nm
Average launch power (max) (Note 1)	+0.5 dBm	+4 dBm	+4 dBm
Average launch power (min) (Note 1)	-5.5 dBm	-4.7 dBm	-1 dBm
Extinction ratio (min)	6 dB	6 dB	8.2 dB
Maximum reflected power (Note 1)	-12 dB	-21 dB	-21 dB
Output optical eye mask (Note 2)	See Fig. 1-C1		
Input electrical eye mask (Note 2)	See Fig. 1-C2 and Table 1-C2		
Jitter	See § C 2		
Electrical/optical transfer function	Logic '1' = Higher optical power / Logic '0' = Lower optical power		

NOTE 1 – Power is average power measured with an average-reading power meter.

NOTE 2 – One thousand accumulated waveforms is recommended for transmitter optical output eye mask compliance test.

FIGURE 1-C1
Transmitter output optical eye mask

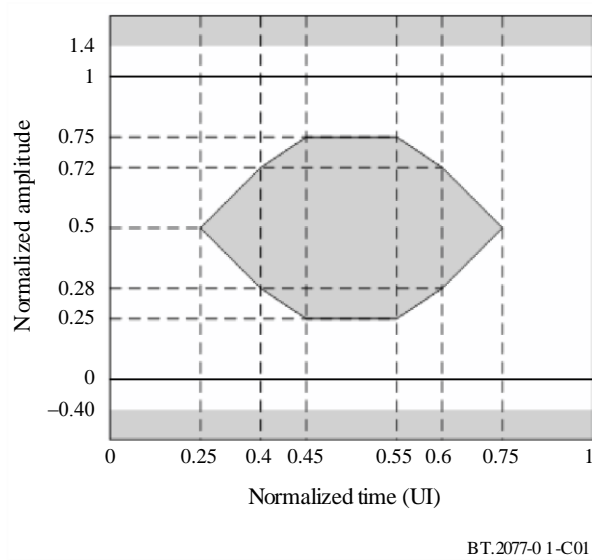

FIGURE 1-C2
Transmitter differential input electrical eye mask

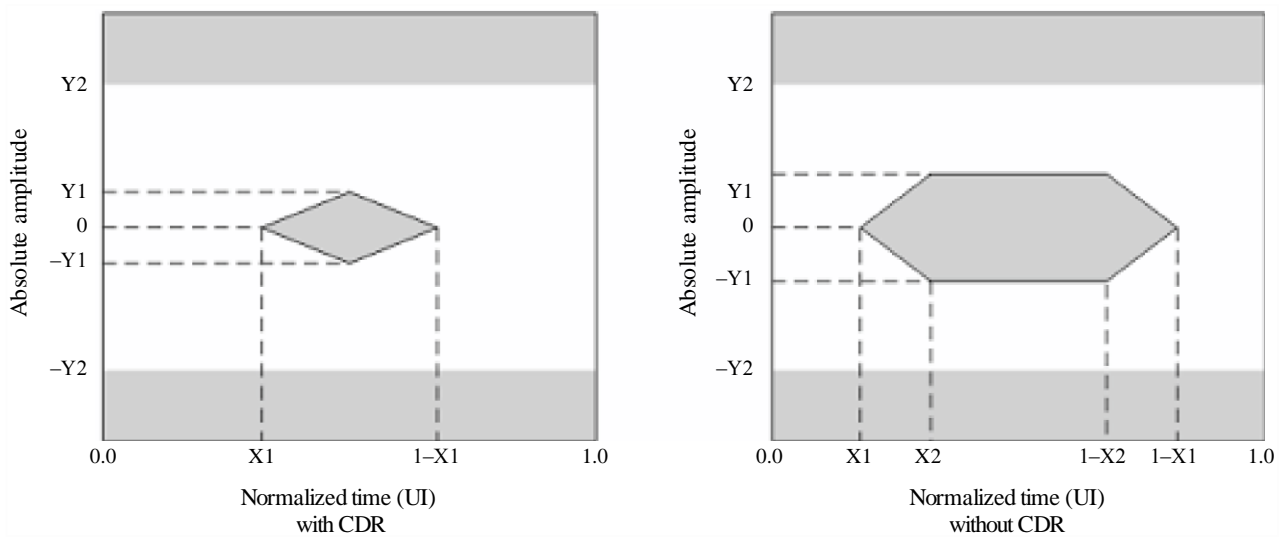

TABLE 1-C2

Transmitter differential input electrical eye mask specifications

Application		With CDR	Without CDR
Eye mask	x1	0.305 UI max	0.12 UI max
Eye mask	x2	NA	0.33 UI max
Eye mask	Y1	60 mV min	95 mV min
Eye mask	Y2	410 mV max	350 mV max

C1.2 Optical fibre characteristics should be as defined in Table 1-C3

The specified connectors for the optical transceiver should be LC/PC simplex/duplex as defined by IEC 61754-20. The connectors on the other side of adapter cables installed between the optical transceivers and patch panels may optionally be specified as SC, ST, FC, MU etc.

TABLE 1-C3

Optical fibre link characteristics

Fibre type	Single mode (as defined by IEC 60793-2)
Connector	LC/PC simplex/duplex (as defined by IEC 61754-20)

Receiver characteristics should be as defined in Table 1-C4.

The electrical output with and without clock data recovery (CDR) at the connector of a receiver module on a host board should be as defined in Fig. 1-C3, Table 1-C4, Table 1-C5 and Table 1-C6.

Within the receiver input range a BER $< 10^{-12}$ should be achieved with the test signals defined in Recommendation ITU-R BT.1729 or PRBS $2^{31}-1$ pattern (when testing system components with BER testers).

A BER $< 10^{-14}$ is recommended.

NOTE – The PRBS $2^{31}-1$ pattern generator is defined in IEEE 802.3ae-2002.

TABLE 1-C4

Optical receiver characteristics

Nominal wavelength	1310 nm	1550 nm	1550 nm DWDM applications
Average receive power (max) (Note 1)	0.5 dBm	-1 dBm	-1 dBm
Average receive power (min) (BER = 10^{-12}) (Note 1, 2)	-13.5 dBm	-13.5 dBm	-15.5 dBm
Detector damage threshold (min) (Note 3)	+1 dBm	+4 dBm	+4 dBm
Output electrical eye mask (Note 4)	See Fig. 1-C3, Table 1-C5 and Table 1-C6		
Jitter	See § C2.1		
Optical/electrical transfer function	Higher optical power = Logic '1' / Lower optical power = Logic '0'		

NOTE 1 – Power is average power measured with an average-reading power meter.

NOTE 2 – Measurement for 5 minutes is recommended for verifying BER $< 10^{-12}$ when using a BER-based test equipment.

NOTE 3 – To avoid the receiver damage when connected to the 1550 nm transmitter, the detector damage threshold of greater than +4 dBm is recommended.

NOTE 4 – One thousand accumulated waveforms is recommended for receiver electrical output eye compliance test.

FIGURE 1-C3

Receiver differential output electrical eye mask

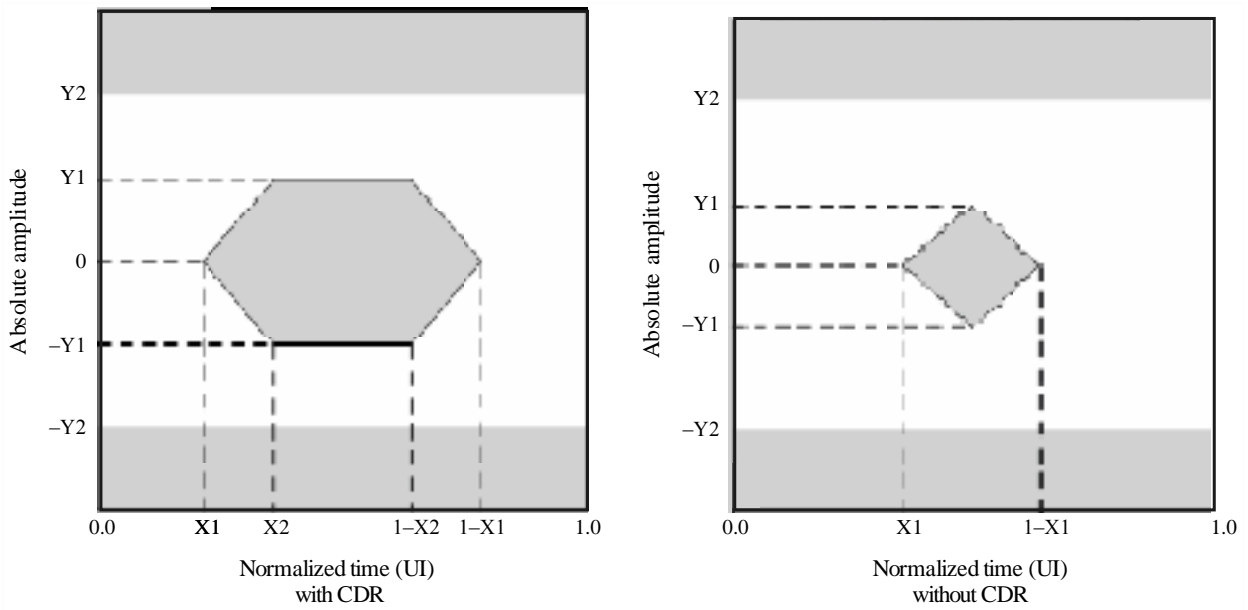

BT.2077-0 1-C03

TABLE 1-C5

Optical transceiver input, receiver output electrical specifications

Application	With CDR	Without CDR
Differential input/Output impedance (typ)	100 ohm	100 ohm
Termination mismatch (max)	5%	5%
Differential input/Output return loss (min) SDD11/SDD22	20 dB (0.05-0.1 GHz)	Note 2 (0.01-4.1 GHz)
	8 dB (0.1-5.5 GHz)	
	Note 1 (5.5-12 GHz)	Note 3 (4.1-11.1 GHz)
Common mode input/ Output return loss (min) SCC11 (Note 5)/SCC22	3 dB (0.1-15 GHz)	Note 4 (0.01-2.5 GHz)
		3 dB (2.5-11.1 GHz)

NOTE 1 – Differential return loss is given by the equation $SDD11$ (dB) and $SDD22$ (dB) = $8 - 20.66 \times \log_{10}(f / 5.5)$, with f in GHz.

NOTE 2 – Differential return loss is given by the equation $SDD11$ (dB) and $SDD22$ (dB) = $12 - 2 \times \text{SQRT}(f)$, with f in GHz.

NOTE 3 – Differential return loss is given by the equation $SDD11$ (dB) and $SDD22$ (dB) = $6.3 - 13 \times \log_{10}(f / 5.5)$, with f in GHz.

NOTE 4 – Common mode output return loss is given by the equation $SCC22$ (dB) = $7 - 1.6 \times f$, with f in GHz.

NOTE 5 – Common mode input return loss $SCC11$ is not specified for the input characteristics of applications without CDR.

TABLE 1-C6

Receiver differential output electrical eye mask specifications

Application		With CDR	Without CDR
Eye mask	x1	0.17 UI max	0.35 UI max
Eye mask	x2	0.42 UI max	NA
Eye mask	Y1	170 mV min	150 mV min
Eye mask	Y2	425 mV max	425 mV max

C2 Serial fibre interface jitter specifications

C2.1 Jitter in the timing of transitions of the data signal should be measured in accordance with Recommendation ITU-R BT.1363

Measurement parameters are defined in Recommendation ITU-R BT.1363 and should have the values defined in Table 1-C7. Jitter specification defined in this section should be applied to the optical receivers equipped with CDR.

TABLE 1-C7

Jitter specifications

Parameter	Value	Description
f_1	10 Hz	Low-frequency specification limit
f_2	20 kHz	Upper band edge for A1
f_3	4 MHz	Lower band edge for A2
f_4	> 1/10 the clock rate	High-frequency specification limit
A1	10 UI	Timing jitter: Sinusoidal jitter amplitude should be less than $2 \times 10^5/f + 0.1$ UI at $20 \text{ kHz} < f \leq 4 \text{ MHz}$
A2	0.15 UI	Alignment jitter: sinusoidal jitter amplitude should be less than 0.15 UI at $f > 4 \text{ MHz}$
Error criterion	BER = 10^{-12}	Criterion for onset of errors
Test signal	PRBS $2^{31}-1$ or ITU-R test signal	Data rate of PRBS $2^{31}-1$ should be 10.692 Gbit/s or 10.692/1.001 Gbit/s or ITU-R BT.1729 Test signal encoded into each basic stream according to Part 1 of this Recommendation (Note 1, 2)

NOTE 1 – Any of applicable image system and mapping mode can be used for the measurement.

NOTE 2 – ITU-R Test signal Recommendation ITU-R BT.1729 is chosen for on-site jitter measurements.

NOTE 3 – See Recommendation ITU-R BT.1363 for definition of jitter terms.

C2.2 Optical transmitter and receiver should meet the requirements defined in Table 1-C8 and Table 1-C9

TABLE 1-C8

Optical module transmitter requirements

Parameter	Symbol	Conditions	Min	Typ	Max
Jitter transfer bandwidth	BW	PRBS $2^{31}-1$			8 MHz
Jitter peaking		Frequency > 50 kHz			1 dB

TABLE 1-C9

Optical module receiver requirements

Parameter	Symbol	Conditions	Min	Typ	Max
Jitter transfer bandwidth	BW	PRBS $2^{31}-1$			8 MHz
Jitter peaking		Frequency > 50 kHz			1 dB

PART 2

1 Definition of terms

8K image	7 680 × 4 320 pixel image specified for the UHDTV2 system
4K image	3 840 × 2 160 pixel image specified for the UHDTV1 system
4K Sub-Image	3 840 × 2 160 pixel image of each colour component obtained by sub-sampling of an 8K image
Basic image	1 920 × 1 080 pixel image of each colour component obtained by sub-sampling of a 4K image or 4K sub-image
8K/ <i>Fr</i>	8K image with frame frequency of <i>Fr</i> (<i>Fr</i> = 120, 120/1.001, 100, 60, 60/1.001, 50, 30, 30/1.001, 25, 24, 24/1.001)
4K/ <i>Fr</i>	4K image with frame frequency of <i>Fr</i> (<i>Fr</i> = 120, 120/1.001, 100, 60, 60/1.001, 50, 30, 30/1.001, 25, 24, 24/1.001)
4Ks/ <i>Fr</i>	4K Sub-Image with frame frequency of <i>Fr</i> (<i>Fr</i> = 120, 120/1.001, 100, 60, 60/1.001, 50, 30, 30/1.001, 25, 24, 24/1.001)
2K/ <i>Fr</i>	Basic image with frame frequency of <i>Fr</i> (<i>Fr</i> = 120, 120/1.001, 100, 60, 60/1.001, 50, 30, 30/1.001, 25, 24, 24/1.001)
Basic stream	A 12-bit-word multiplexed data stream which consists of a four-word EAV (end of active video) timing reference code, a two-word line number (LN), a two-word CRCC (cyclic redundancy check code) error detection code, ancillary data or blanking data, a four-word SAV (start of active video) timing reference code, and video data
Active line	1920 words of data that constitute one line of a basic image
Active frame	1080 lines that include all active lines
Frame blanking	The lines between an active frame and the next active frame
Running disparity	A binary parameter indicating the cumulative disparity (positive or negative) of all previously issued transmission characters

2 Video data signals**2.1 Overview of mapping from 8K or 4K images to 10G link signals****2.1.1 Mapping of 8K or 4K images with 120 Hz, 120/1.001 Hz or 100 Hz frame frequency**

The mapping of 8K images with 120 Hz, 120/1.001 Hz or 100 Hz frame frequency to multiple 10G link signals should be as illustrated in Fig. 2-1 and the mapping of 4K images with 120 Hz, 120/1.001 Hz or 100 Hz frame frequency should be as illustrated in Fig. 2-2. The colour components, C1, C2, and C3 of each figure should be respectively represented as Y' , C'_B , and C'_R or G' , B' , and R' .

For 8K/*Fr* (*Fr* = 120, 120/1.001, 100), the three colour components that constitute the image should be respectively divided into four to produce N (N = 6, 8, or 12) 4K sub-images, each of which is then further divided to produce $4N$ basic images. Those $4N$ basic images should be converted to $4N$ basic streams, each two of which are mapped to one 10G link signal to generate $2N$ 10G link signals.

For $4K/Fr$ ($Fr = 120, 120/1.001, 100$), the three colour components that constitute the image should be respectively divided into four to produce M ($M = 6, 8, \text{ or } 12$) basic images. The M basic images should be then converted to M basic streams, each two of which are mapped to one 10G link signal to generate 4 or 6 10G link signals. The reason for there being no $M/2$ is that 10G link signals are generated for each colour component. Detailed specifications are in § 4.2.4.

FIGURE 2-1

Mapping overview of 8K images with 120 Hz, 120/1.001 Hz or 100 Hz frame frequency

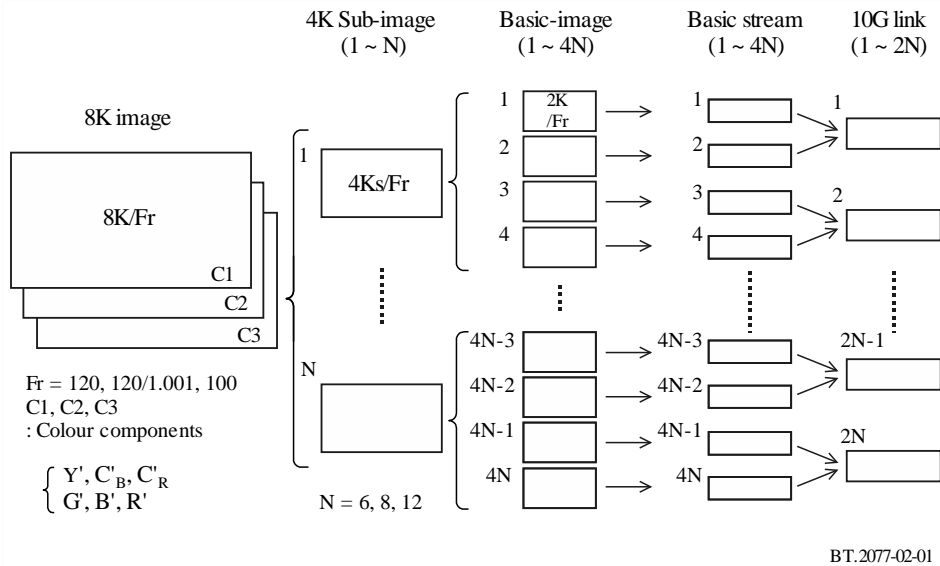
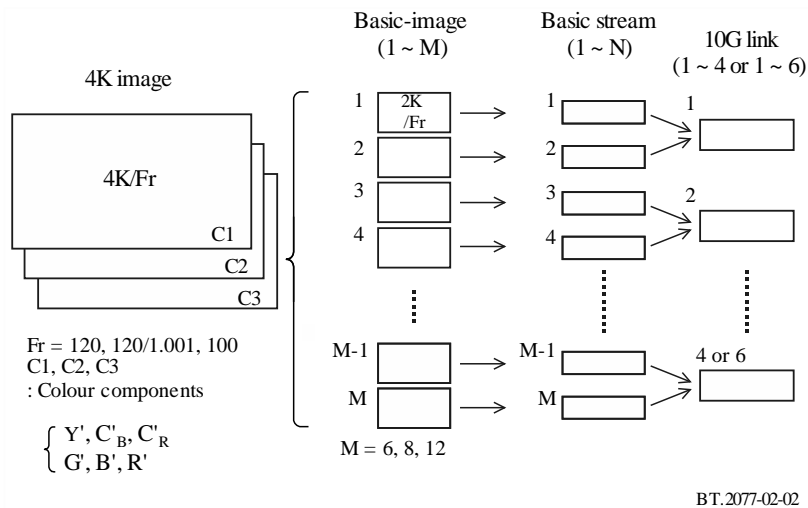

FIGURE 2-2

Mapping overview of 4K images with 120 Hz, 120/1.001 Hz or 100 Hz frame frequency



2.1.2 Mapping of 8K or 4K images with 60 Hz, 60/1.001 Hz or 50 Hz frame frequency

The mapping of 8K images with 60 Hz, 60/1.001 Hz or 50 Hz frame frequency to multiple 10G link signals should be as illustrated in Fig. 2-3 and the mapping of 4K images with 60 Hz, 60/1.001 Hz or 50 Hz frame frequency should be as illustrated in Fig. 2-4.

For 8K/ Fr ($Fr = 60, 60/1.001, 50$), the three colour components that constitute the image should be respectively divided into four to produce N ($N = 6, 8, \text{ or } 12$) 4K sub-images, and then $4N$ basic images should be generated. Next, the $4N$ basic images are converted to $4N$ basic streams, each four of which should be mapped to one 10G link signal to generate N 10G link signals.

For 4K/ Fr ($Fr = 60, 60/1.001, 50$), the three colour components that constitute the image should be respectively divided into four to produce M ($M = 6, 8, \text{ or } 12$) basic images. The M basic images should be then converted to M basic streams, each four of which should be mapped to one 10G link signal to generate three 10G link signals. The reason for there being no $M/4$ is that 10G link signals are generated for each colour component. Detailed specifications are in § 4.2.5.

FIGURE 2-3

Mapping overview of 8K images with 60 Hz, 60/1.001 Hz or 50 Hz frame frequency

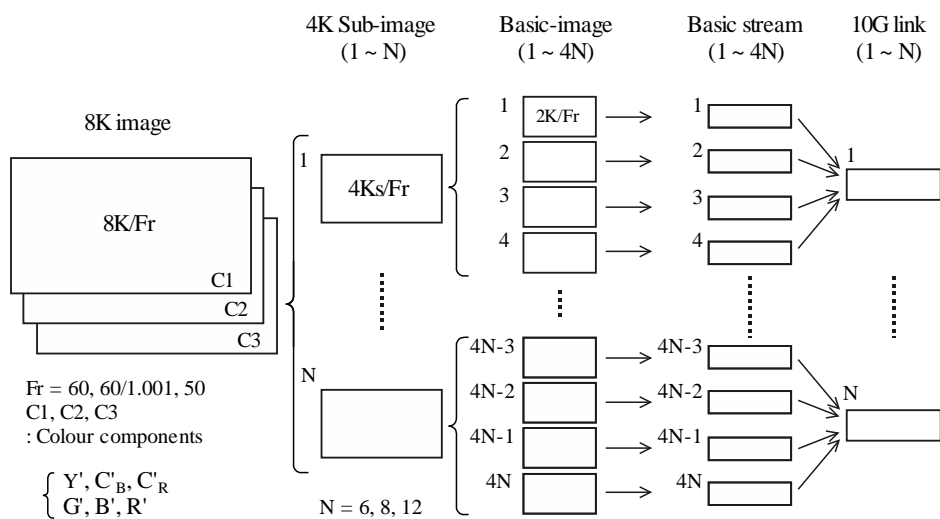
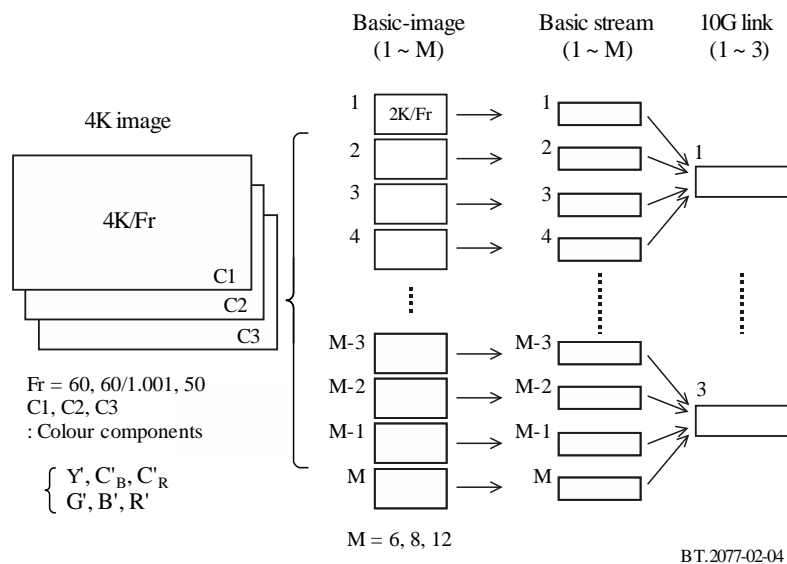

FIGURE 2-4

Mapping overview of 4K images with 60 Hz, 60/1.001 Hz or 50 Hz frame frequency



2.1.3 Mapping of 8K or 4K images with 30 Hz, 30/1.001 Hz, 25 Hz, 24 Hz or 24/1.001 Hz frame frequency

The mapping of 8K images with 30 Hz, 30/1.001 Hz, 25 Hz, 24 Hz or 24/1.001 Hz frame frequency to multiple 10G link signals should be as illustrated in Fig. 2-5 and the mapping of 4K images with 30 Hz, 30/1.001 Hz, 25 Hz, 24 Hz or 24/1.001 Hz frame frequency should be as illustrated in Fig. 2-6.

For $8K/Fr$ ($Fr = 30, 30/1.001, 25, 24, 24/1.001$), the three colour components that constitute the image should be respectively divided into four to produce N ($N = 6, 8, \text{ or } 12$) 4K sub-images, and then $4N$ basic images should be generated. Next, the $4N$ basic images should be converted to $4N$ basic streams, each eight of which should be mapped to one 10G link signal to generate 4 or 6 10G link signals. The reason for there being no $N/2$ is that 10G link signals are generated for each colour component. Detailed specifications are in § 4.2.3.

For $4K/Fr$ ($Fr = 30, 30/1.001, 25, 24, 24/1.001$), the three colour components that constitute the image should be respectively divided into four to produce M ($M = 6, 8, \text{ or } 12$) basic images. The M basic images should be then converted to M basic streams, each eight of which should be mapped to one 10G link signal to generate three 10G link signals. The reason for there being no $M/8$ is that 10G link signals are generated for each colour component. Detailed specifications are in § 4.2.6.

FIGURE 2-5

Mapping overview of 8K images with 30 Hz, 30/1.001 Hz, 25 Hz, 24 Hz or 24/1.001 Hz frame frequency

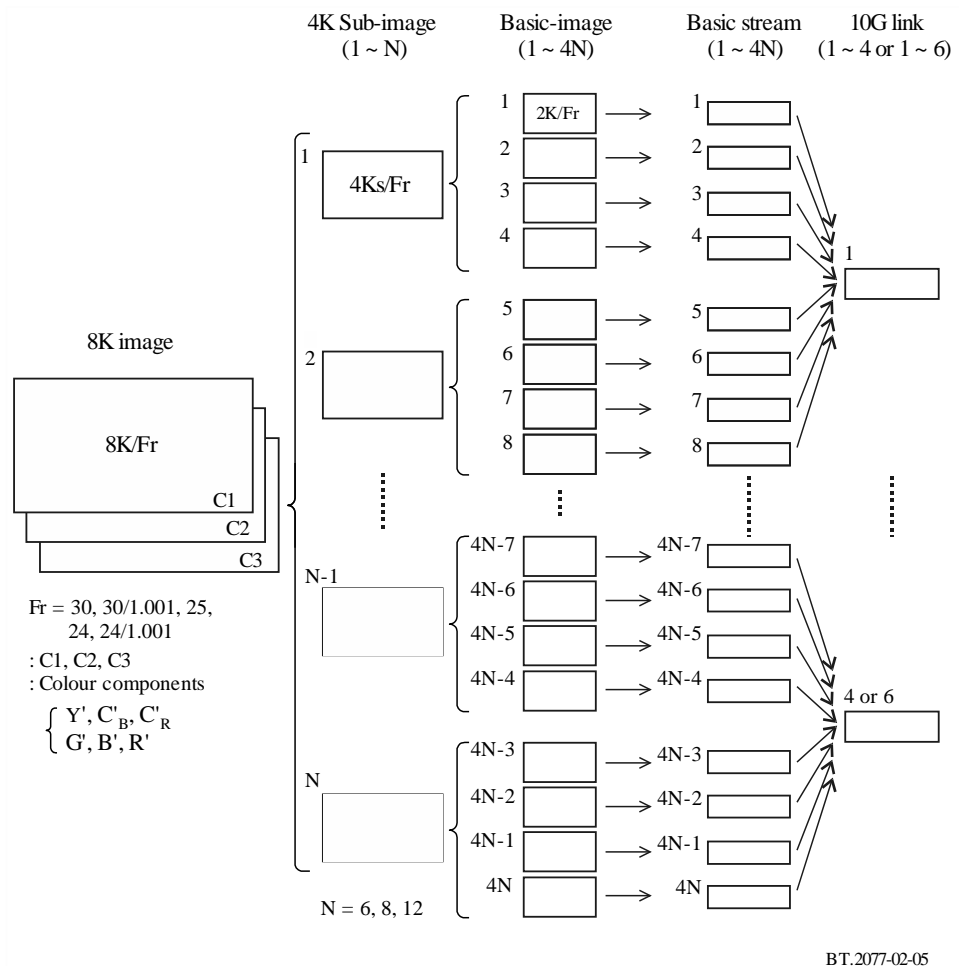
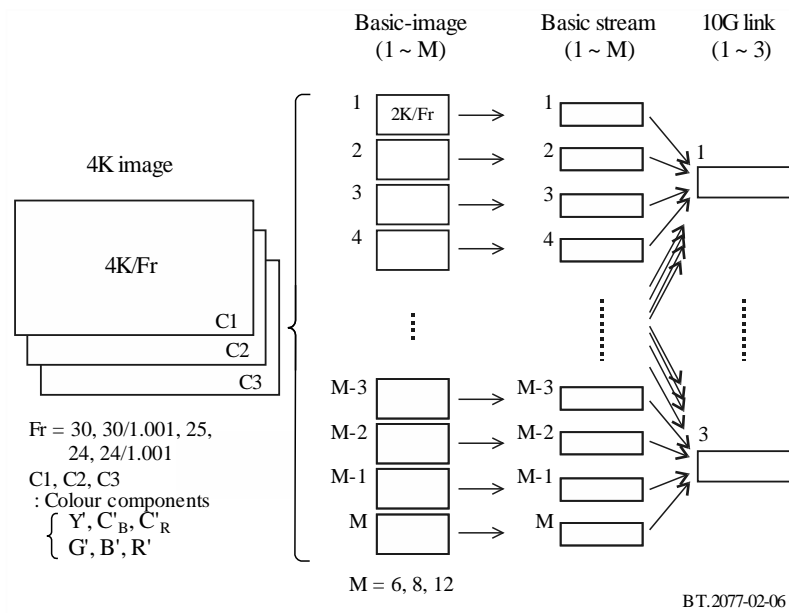

FIGURE 2-6

Mapping overview of 4K images with 30 Hz, 30/1.001 Hz, 25 Hz, 24 Hz or 24/1.001 Hz frame frequency



2.1.4 Configuration of colour signal component and system ID

Figure 2-7 illustrates the image division of 8K images into 4K sub-images and 4K images into basic images when the sampling structures for 8K images and 4K images are 4:2:2 ($Y'C'_B C'_R$) or 4:2:0 ($Y'C'_B C'_R$).

For the 4:2:2 ($Y'C'_B C'_R$) sampling structure, the colour components of the 4K sub-images generated from the 8K images should be limited to $Y_1, Y_2, Y_3, Y_4, C_{B1}, C_{B3}, C_{R1},$ and C_{R3} and the colour components of the basic images generated from the 4K image should be limited to $y_1, y_2, y_3, y_4, c_{B1}, c_{B3}, c_{R1},$ and c_{R3} .

For the sampling structure 4:2:0 ($Y'C'_B C'_R$), the colour components of the 4K sub-images generated from the 8K images should be limited to $Y_1, Y_2, Y_3, Y_4, C_{B1}, C_{R1}$ and the colour components of the basic images generated from the 4K image should be limited to $y_1, y_2, y_3, y_4, c_{B1},$ and c_{R1} .

FIGURE 2-7

Image division of 4:2:2 (Y'C'B'C'R) and 4:2:0 (Y'C'B'C'R) systems

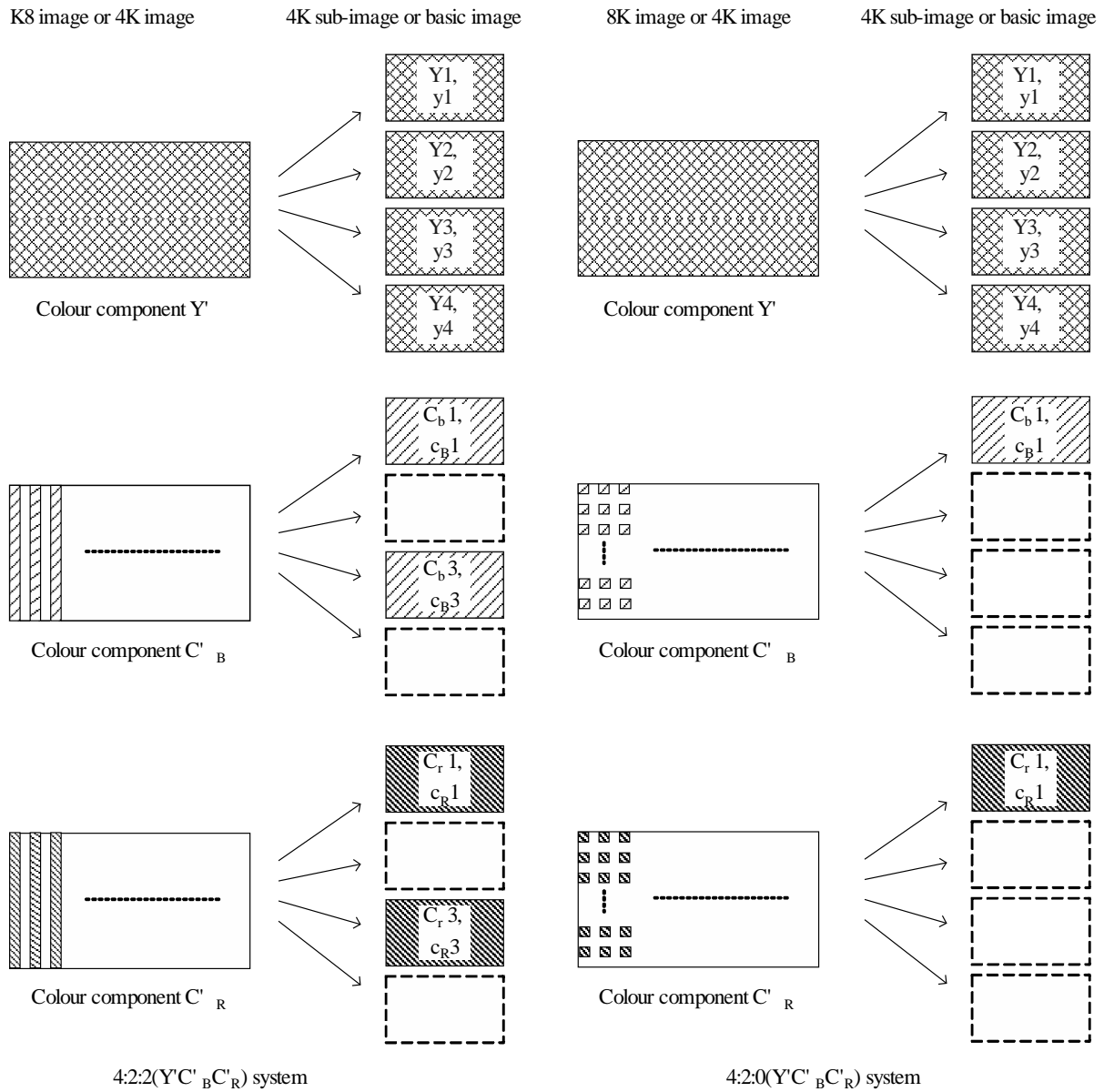

BT.2077-02-07

The system numbers for identifying the image format are defined in Table 2-1 for 8K images and in Table 2-2 for 4K images.

TABLE 2-1

8K Image formats

8K image Sampling structure	4K sub-image		Frame frequency (Hz)	Number of 10G links	System number
	Number of sub-images (<i>N</i>)	Elements of colour components			
8K, 4:4:4(G'B'R')	12	G1, G2, B1, B2, R1, R2, G3, G4, B3, B4, R3, R4	120, 120/1.001	24	U2.1
			100	24	U2.2
			60, 60/1.001	12	U2.3
			50	12	U2.4
			30, 30/1.001	6	U2.5
			25	6	U2.6
			24, 24/1.001	6	U2.7
8K, 4:4:4(Y'C'B'C'R')	12	Y1, Y2, C _{B1} , C _{B2} , C _{R1} , C _{R2} , Y3, Y4, C _{B3} , C _{B4} , C _{R3} , C _{R4}	120, 120/1.001	24	U2.8
			100	24	U2.9
			60, 60/1.001	12	U2.10
			50	12	U2.11
			30, 30/1.001	6	U2.12
			25	6	U2.13
			24, 24/1.001	6	U2.14
8K, 4:2:2(Y'C'B'C'R')	8	Y1, Y2, C _{B1} , C _{R1} , Y3, Y4, C _{B3} , C _{R3}	120, 120/1.001	16	U2.15
			100	16	U2.16
			60, 60/1.001	8	U2.17
			50	8	U2.18
			30, 30/1.001	4	U2.19
			25	4	U2.20
			24, 24/1.001	4	U2.21
8K, 4:2:0(Y'C'B'C'R')	6	Y1, Y2, C _{B1} , C _{R1} , Y3, Y4	120, 120/1.001	12	U2.22
			100	12	U2.23
			60, 60/1.001	6	U2.24
			50	6	U2.25
			30, 30/1.001	4	U2.26
			25	4	U2.27
			24, 24/1.001	4	U2.28

TABLE 2-2
4K Image formats

4K image Sampling structure	Basic image		Frame frequency (Hz)	Number of 10G links	System number
	Number of basic images (M)	Elements of colour components			
4K, 4:4:4(G'B'R')	12	g1, g2, b1, b2, r1, r2, g3, g4, b3, b4, r3, r4	120, 120/1.001	6	U1.1
			100	6	U1.2
			60, 60/1.001	3	U1.3
			50	3	U1.4
			30, 30/1.001	3	U1.5
			25	3	U1.6
			24, 24/1.001	3	U1.7
4K, 4:4:4(Y'C'B'C'R')	12	y1, y2, c _{B1} , c _{B2} , c _{R1} , c _{R2} , y3, y4, c _{B3} , c _{B4} , c _{R3} , c _{R4}	120, 120/1.001	6	U1.8
			100	6	U1.9
			60, 60/1.001	3	U1.10
			50	3	U1.11
			30, 30/1.001	3	U1.12
			25	3	U1.13
			24, 24/1.001	3	U1.14
4K, 4:2:2(Y'C'B'C'R')	8	y1, y2, c _{B1} , c _{R1} , y3, y4, c _{B3} , c _{R3}	120, 120/1.001	4	U1.15
			100	4	U1.16
			60, 60/1.001	3	U1.17
			50	3	U1.18
			30, 30/1.001	3	U1.19
			25	3	U1.20
			24, 24/1.001	3	U1.21
4K, 4:2:0(Y'C'B'C'R')	6	y1, y2, c _{B1} , c _{R1} , y3, y4	120, 120/1.001	4	U1.22
			100	4	U1.23
			60, 60/1.001	3	U1.24
			50	3	U1.25
			30, 30/1.001	3	U1.26
			25	3	U1.27
			24, 24/1.001	3	U1.28

2.2 Division of 8K images into 4K Sub-Images

The division of 8K images into 4K sub-images should be as illustrated in Fig. 2-8. In the line numbering for each 8K image sample, the uppermost line in the vertical direction should be line number 1 and the lowermost line should be line number 4320; the leftmost sample in the horizontal direction should be sample number 0 and the rightmost sample should be sample number 7679. The numbering for each sample of the 4K sub-images should be done similarly, with the uppermost line in the vertical direction as line number 1 and the lowest line as line number 2160, and the leftmost sample in the horizontal direction as sample number 0 and the rightmost sample as sample number 3839. The even-numbered samples of the odd lines of the 8K images should be mapped to 4K sub-

image 1 and the odd-numbered samples of the odd lines of the 8K images should be mapped to 4K sub-image 2; the even-numbered samples of the even lines of the 8K images should be mapped to 4K sub-image 3 and the odd-numbered samples of the even lines of the 8K images should be mapped to 4K sub-image 4.

FIGURE 2-8

Image division from 8K images to 4K sub-images

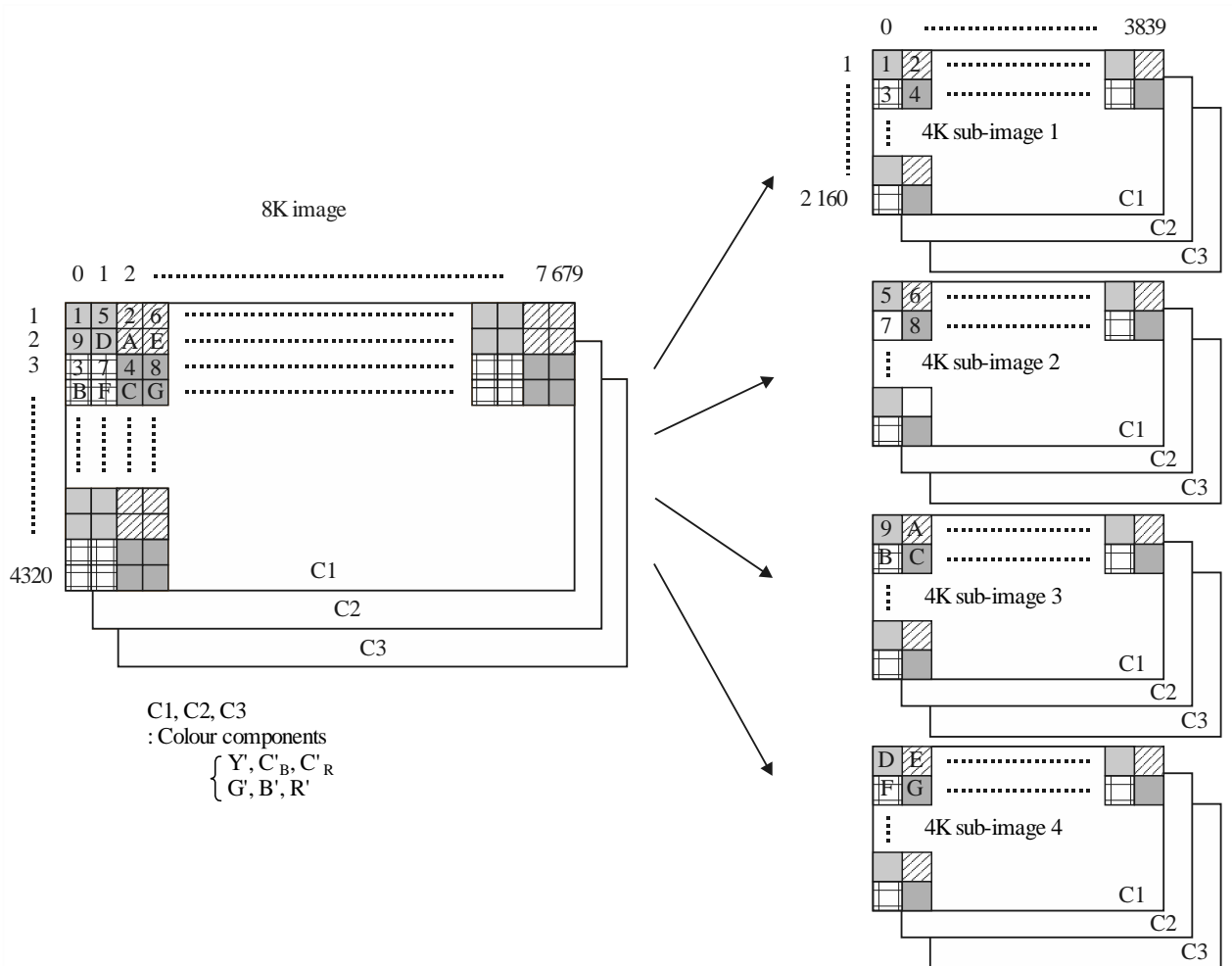

BT.2077-02-08

2.3 Division of 4K images and 4K sub-images into basic images

The division of 4K images and 4K sub-images into basic images should be as illustrated in Fig. 2-9. The numbering for each sample of the 4K Images should be done in the same way as for the 4K sub-images, with the uppermost line in the vertical direction as line number 1 and the lowest line as line number 2160, and the leftmost sample in the horizontal direction as sample number 0 and the rightmost sample as sample number 3839. The numbering for each sample of the basic images should be done similarly, with the uppermost line in the vertical direction as line number 1 and the lowest line as line number 1080, and the leftmost sample in the horizontal direction as sample number 0 and the rightmost sample as sample number 1919.

The even-numbered samples of the odd lines of the 4K images and 4K sub-images should be mapped to basic image 1 and the odd-numbered samples of the odd lines of the 4K images and 4K sub-images should be mapped to basic image 2; the even-numbered samples of the even lines of the 4K images and 4K sub-images should be mapped to basic image 3 and the odd-numbered samples of the even lines of the 4K images and 4K sub-images should be mapped to basic image 4.

FIGURE 2-9
Image division of 4K images or 4K sub-image into basic images

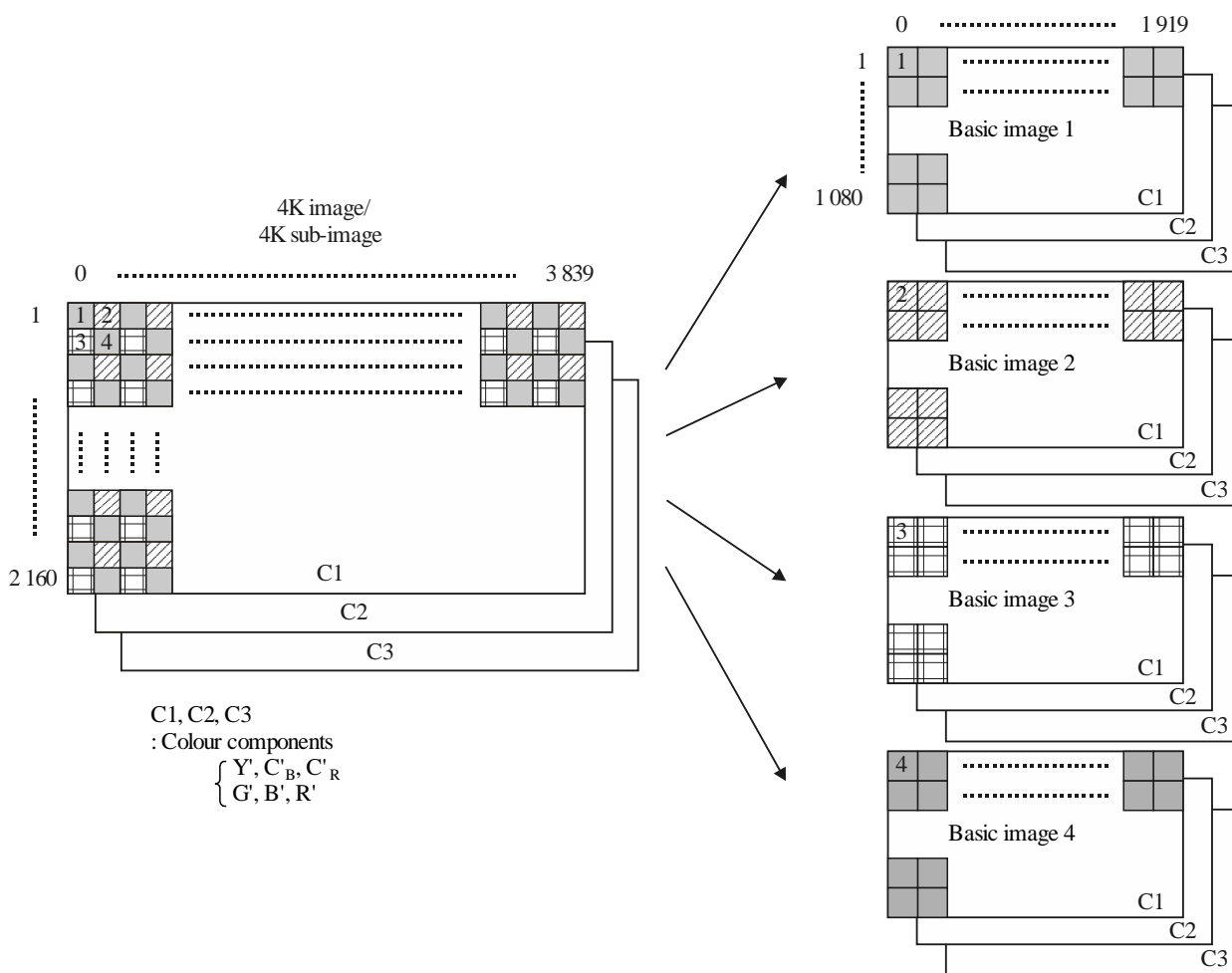

BT.2077-02-09

3 Basic stream

3.1 Conversion from basic images to basic streams

The method for converting each line when converting basic images to basic streams should be as shown in Fig. 2-10. Each sample of the basic image is either 10 bits or 12 bits. For the 10 bit case, a two-bit shift should be done to fill the lowest two bits with “00” to produce a 12-bit word so that the word for all of the basic streams is 12 bits.

As shown in Fig. 2-10, the one line period of basic stream should consist of a four-word EAV (End of Active Video) timing reference code, a two-word LN, a two-word CRCC error detection code, ancillary data or blanking data, a four-word SAV timing reference code, and video data. The sample numbers of a basic stream should be determined as shown in Table 2-3.

FIGURE 2-10
Line structure of basic stream

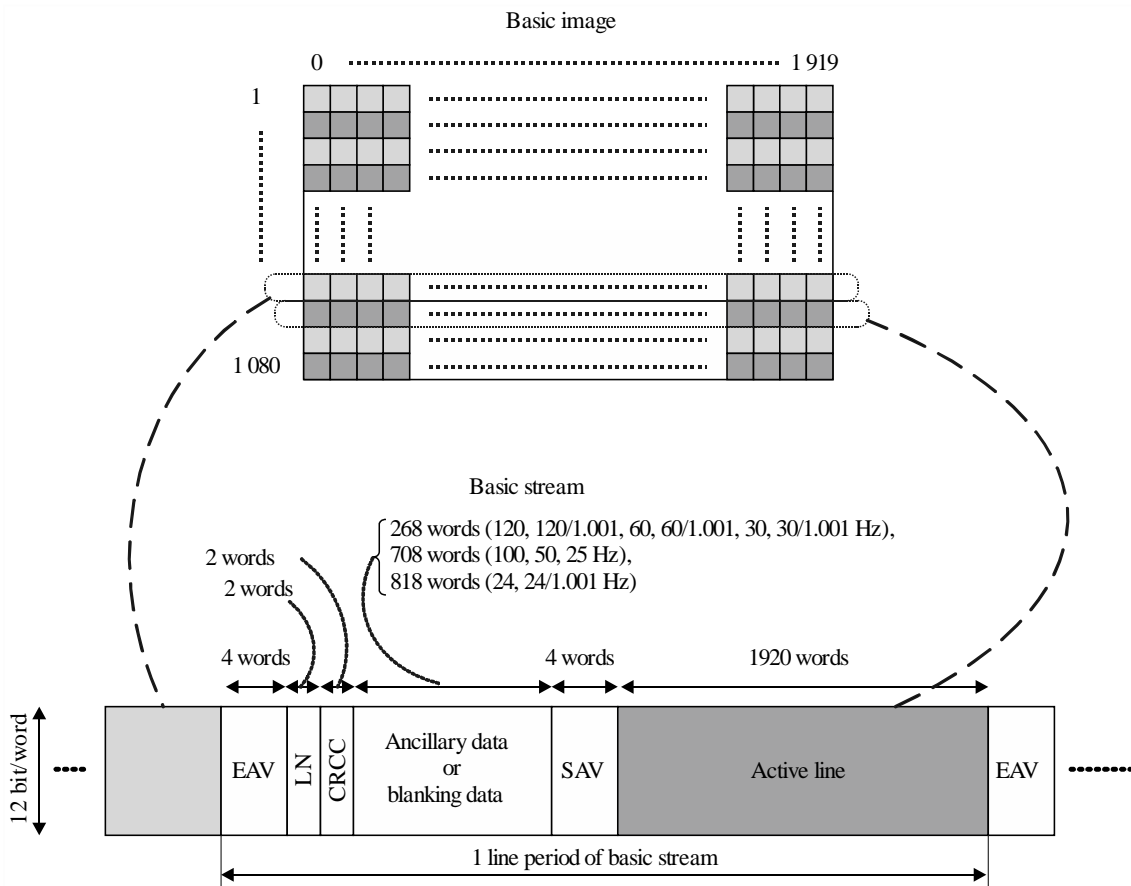

TABLE 2-3

Sample numbers of basic stream

Item	Symbol	Sample number		
		120, 120/1.001, 60, 60/1.001, 30 or 30/1.001 Hz frame frequency	100, 50 or 25 Hz frame frequency	24 or 24/1.001 Hz frame frequency
Active line (video data)	D	0-1919		
Timing reference code (EAV)	EAV	1 920, 1 921, 1 922, 1 923		
Line number data	LN	LN0	1 924	
		LN1	1 925	
Cyclic redundancy check codes	CRCC	CRCC0	1 926	
		CRCC1	1 927	
Ancillary data or Blanking data	ANC	1 928-2 195	1 928-2 635	1 928-2 745
Timing reference code (SAV)	SAV	2 196, 2 197, 2 198, 2 199	2 636, 2 637, 2 638, 2 639	2 746, 2 747, 2 748, 2 749

The frame structure of a basic stream should be as shown in Fig. 2-11 and the basic stream line numbering should be as shown in Table 2-4. A basic stream should comprise 1 080-line active frame and 45-line frame blanking intervals. The samples from the first line of a basic image to the 1 080th line should be assigned to ones from line 42 to line 1 121 of the basic stream. The frame blanking should be assigned to the interval from line 1 to line 41 and from line 1 122 to line 1 125. The line structure of the frame blanking should be same as that of the active frame shown in Fig. 2-10, with a 1 920-word region of the active line allocated to the ancillary data or blanking data.

FIGURE 2-11

Frame structure of basic stream

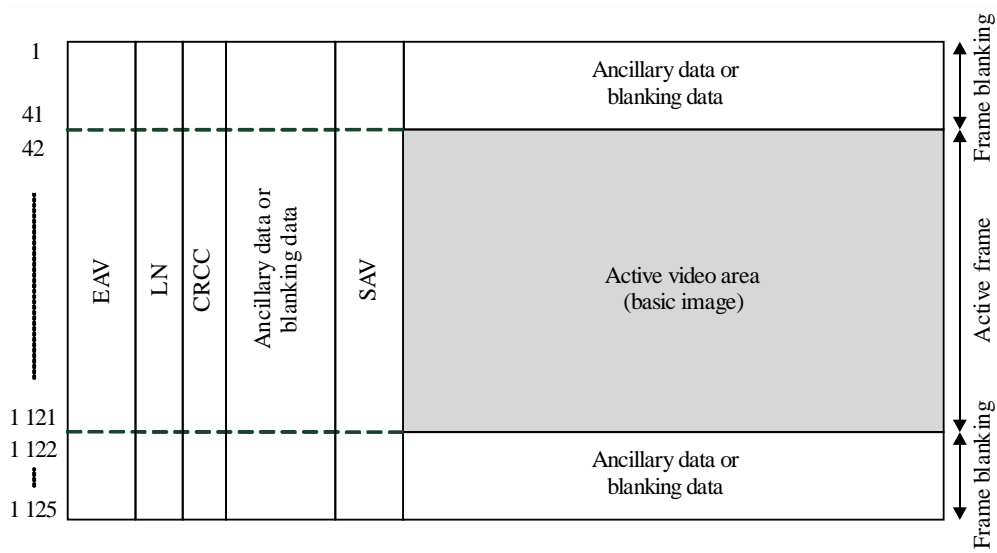

BT.2077-02-11

TABLE 2-4

Line numbers of basic stream

Item	Line number
Frame blanking	1-41, 1 122-1 125
Active frame	42-1 121

3.2 Timing reference codes (SAV and EAV)

The two timing reference codes are the SAV, which should be placed immediately before the video data (active line), and the EAV, which should be placed immediately after the video data. The bit assignments for the SAV and EAV should be as shown in Table 2-5 and the protection bit assignments should be as shown in Table 2-6.

In Tables 2-5 and 2-6, F is an identification bit for progressive/interlaced (first/second field). The images in Parts 2 of this Recommendation should be progressive, so the value of F should be fixed at 0. The V is an identifier bit for the frame blanking and the active video data. The value of V should be 1 in the frame blanking from line 1 to line 41 and from line 1122 to line 1125; the value should be 0 in the active video data from line 42 to line 1121. The H is an identifier bit that has a value of 0 for SAV and 1 for EAV. The values P0 through P3 are parity bits, which are used for one bit error correction and two bits error detection on the receiving side. The assignment of those bits should be as shown in Table 2-6.

TABLE 2-5

Bit assignment for timing reference codes

Word	Value	Bit number											
		b11 (MSB)	b10	b9	b8	b7	b6	b5	b4	b3	b2	b1	b0 (LSB)
1	FFFh	1	1	1	1	1	1	1	1	1	1	1	1
2	000h	0	0	0	0	0	0	0	0	0	0	0	0
3	000h	0	0	0	0	0	0	0	0	0	0	0	0
4	XYZ	1	F	V	H	P ₃	P ₂	P ₁	P ₀	0	0	0	0

TABLE 2-6

Protection bits for timing reference codes

Bit number	b10	b9	b8	b7	b6	b5	b4
Function	F	V	H	P ₃	P ₂	P ₁	P ₀
Bit pattern 0	0	0	0	0	0	0	0
Bit pattern 1	0	0	1	1	1	0	1
Bit pattern 2	0	1	0	1	0	1	1
Bit pattern 3	0	1	1	0	1	1	0

3.3 Line number data

The line numbering of the basic stream should use the line numbers for the basic stream specified in Fig. 2-11 and Table 2-4 rather than the line numbers of the 8K or 4K image. The line number data should be represented in binary format using the 11 bits from L0 (LSB) to L10 (MSB). The bit assignment of line number data LN0 and LN1 should be as shown in Table 2-7. The reserved bits of Table 2-7 should be set to "0".

TABLE 2-7

Bit assignment for line number

Bit number	LN0	LN1
b11 (MSB)	NOT b10	NOT b10
b10	L6	Reserved
b9	L5	Reserved
b8	L4	Reserved
b7	L3	L10 (MSB)
b6	L2	L9
b5	L1	L8
b4	L0 (LSB)	L7
b3	Reserved	Reserved

TABLE 2-7 (end)

Bit number	LN0	LN1
b2	Reserved	Reserved
b1	Reserved	Reserved
b0 (LSB)	Reserved	Reserved

3.4 Error detection code data

The basic stream error detection code data should be represented by the 18 bits from CRCC0 to CRCC17 and is defined as follows.

- (1) Error detection code: CRCC (Cyclic Redundancy Check Code)
- (2) Polynomial generator equation: $C(X) = X^{18} + X^5 + X^4 + 1$. The initial value is set to 0.
- (3) Error detection code generation range:
 - Start point: The first word after the SAV of the previous line
 - End point: The last word of the line number data
- (4) Error detection code generation sequence:
 - Should begin with the LSB of the first word of the error detection code generation range and end with the MSB of the last word in that range.
- (5) Bit assignment:
 - Table 2-8 specifies the bit assignment. CRCC0 is the MSB of the error detection code.
 - The reserved bits of Table 2-8 should be set to "0".

TABLE 2-8

Bit assignment for CRCC

Bit number	CRC0	CRC1
b11 (MSB)	NOT b10	NOT b10
b10	CRCC8	CRCC17
b9	CRCC7	CRCC16
b8	CRCC6	CRCC15
b7	CRCC5	CRCC14
b6	CRCC4	CRCC13
b5	CRCC3	CRCC12
b4	CRCC2	CRCC11
b3	CRCC1	CRCC10
b2	CRCC0	CRCC9
b1	Reserved	Reserved
b0 (LSB)	Reserved	Reserved

3.5 Ancillary data

The ancillary data should be mapped into the blanking area of basic stream 1 and basic stream 2. The data format should be in conformance with Recommendation ITU-R BT.1364.

As the ancillary data packet is specified as 10 bits/word, the conversion shown in Fig. 2-12 should apply. In Fig. 2-12, ADF indicates an ancillary data flag, DID indicates a data identifier word, DBN indicates a data block number word, SDID indicates second data identifier word, DC indicates a data count word, UDW indicates a user data word and CS indicates a checksum word.

For the three words of the ADF, “00” should be appended to the lowest two bits of the first word and “11” should be appended to the lowest two bits of the other two words for conversion to 12-bit words. From DID through the end of UDW, the lowest two bits should be filled with “00” to convert to a 12-bit word format. For CS, the lower 11 bits of the sum of the lower 11 bits of the words from DID to the last UDW should be assigned as b0 (LSB) to b10 of CS, and b11 (MSB) should be set as the reverse of b10.

FIGURE 2-12

Conversion of ancillary data packet from 10-bit/word to 12-bit/word

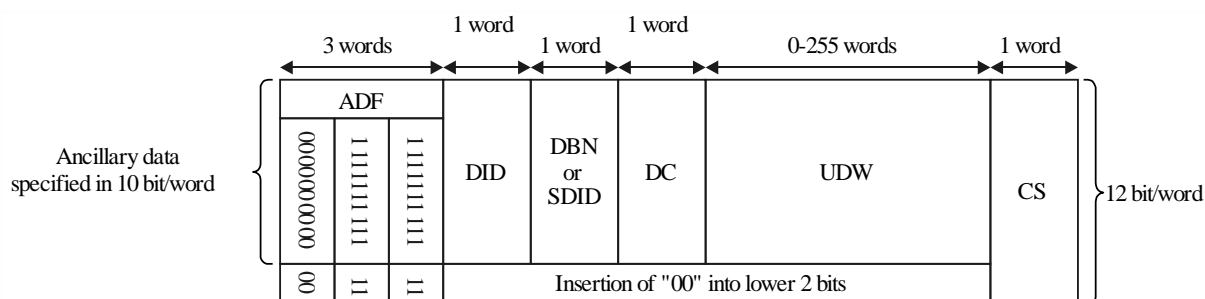

BT.2077-02-12

3.6 Audio

Each basic image has the format of 1 920 × 1 080 pixel image of each colour component obtained by sub-sampling of a 4K image or 4K Sub-Image and should have audio embedded according to Recommendation ITU-R BT.1365. Y data stream and C_B/C_R data stream in Recommendation ITU-R BT.1365 correspond to basic stream 1 and basic stream 2 in Part 2 of this Recommendation, respectively.

Audio control packets should be multiplexed into the horizontal ancillary data space of line 9 of basic stream 1 and audio data packets should be into the horizontal ancillary data space of basic stream 2.

Recommendation ITU-R BT.1365 describes the generation and insertion of audio ancillary data packets, including audio control packets and audio data packets, for up to 4 audio groups, groups 1 through 4. This allows for up to 16 channels of audio sampled at 48 kHz, or up to 8 channels of audio sampled at 96 kHz. A further 4 extended audio groups, groups 5, 6, 7 and 8, allowing for up to 32 channels at 48 kHz or up to 16 channels at 96 kHz, can be inserted using the techniques described in Recommendation ITU-R BT.1365 with different DID values for the audio data packets and audio control packets.

The DID values for extended audio data packets should be 1A7_h for audio group 5, 2A6_h for audio group 6, 2A5_h for audio group 7 and 1A4_h for audio group 8.

The DID values for extended audio control packets should be 2A3_h for audio group 5, 1A2_h for audio group 6, 1A1_h for audio group 7 and 2A0_h for audio group 8.

The audio clock phase data as defined in Recommendation ITU-R BT.1365 should be calculated using a clock frequency of 74.25 (/1.001) MHz for signals with frame frequencies of 30 Hz, 30/1.001 Hz, 25 Hz, 24 Hz and 24/1.001 Hz.

The audio clock phase data as defined in Recommendation ITU-R BT.1365 should be calculated using a clock frequency of 148.5 (/1.001) MHz for 50 Hz, 60/1.001 Hz and 60 Hz.

The audio clock phase data as defined in Recommendation ITU-R BT.1365 should be calculated using a clock frequency of 297 (/1.001) MHz for 100 Hz, 120/1.001 Hz and 120 Hz.

3.7 Payload ID

The UDW bit assignment of payload ID packet should be as shown in Table 2-9. The payload ID packet should be multiplexed once per frame of the basic stream. The recommended location should be immediately after the CRCC of the basic stream in line 10.

The following payload ID values should apply:

- 4K and 8K should be identified by bits b0 and b1 of word 1 having the following values:
 - (0_h) should be reserved,
 - (1_h) should identify 4K,
 - (2_h) should identify 8K,
 - (3_h) should be reserved;
- transfer characteristics should be identified by bits b3 and b4 of word 3 having the following values:
 - (0_h) should identify SDR-TV,
 - (1_h) should identify HLG,
 - (2_h) should identify PQ,
 - (3_h) should be reserved, – picture rate should be set to the value of the UHD TV payload;
- assignment order of the basic stream channels should correspond to:
 - Figure 2-13 for 120, 120/1.001, 100 Hz as defined in § 4.1.1,
 - Figure 2-17 for 60, 60/1.001, 50 Hz as defined in § 4.1.2, and
 - Figure 2-19 for 30, 30/1.001, 25, 24, 24/1.001 Hz as defined in § 4.1.3;
- sampling structure should be set to the value of the payload being carried;
- assignment order of the 10G link channel number should correspond to:
 - Figures 2-21 and 2-22 for 8K/*Fr* (*Fr* = 120, 120/1.001, 100) as defined in § 4.2.1,
 - Figure 2-23 for 8K/*Fr* (*Fr* = 60, 60/1.001, 50) as defined in § 4.2.2,
 - Figure 2-24 for 8K/*Fr* (*Fr* = 30, 30/1.001, 25, 24, 24/1.001) as defined in § 4.2.3,
 - Figure 2-25 for 4K/*Fr* (*Fr* = 120, 120/1.001, 100) as defined in § 4.2.4,
 - Figure 2-26 for 4K/*Fr* (*Fr* = 60, 60/1.001, 50) as defined in § 4.2.5,
 - Figure 2-27 for 4K/*Fr* (*Fr* = 30, 30/1.001, 25, 24, 24/1.001) as defined in § 4.2.6;
- luminance and colour difference signal flag should be set to (0) for non-constant luminance Y'C_BC_R' and (1) for constant luminance SDR Y'C_BC_R' or HDR IC_{TCP};

– the bit depth and narrow/full range coding of the sample quantization should be identified by bits b0 and b1 of word 4 having the following values:

(0_h) should identify quantization using 10 bits per sample with the full range coding,

(1_h) should identify quantization using 10 bits per sample with the narrow range coding,

(2_h) should identify quantization using 12 bits per sample with the narrow range coding,

(3_h) should identify quantization using 12 bits per sample with the full range coding.

TABLE 2-9

Bit assignment of payload ID packet

Bit number	Word 1	Word 2	Word 3	Word 4
b9 (MSB)	NOT b8	NOT b8	NOT b8	NOT b8
b8	EP (Note 1)	EP	EP	EP
b7	1	Progressive (1)	Channel assignment of basic stream CH1 (0 _h), CH2 (1 _h), CH3 (2 _h), CH4 (3 _h), CH5 (4 _h), CH6 (5 _h), CH7 (6 _h) or CH8 (7 _h)	10G link assignment CH1 (00 _h) – CH24 (17 _h)
b6	0	Progressive (1)		
b5	1	Transfer characteristics SDR-TV (0 _h) HLG (1 _h) PQ (2 _h) Unspecified (3 _h)	Luminance and colour difference signal NCL Y'C _B C _R ' (0), CL SDR Y'C _B C _R ' or HDR IC _T C _P ' (1)	Wide-gamut colorimetry as per Recommendation ITU-R BT.2020 (0) Reserved (1)
b4	0			
b3	0	Picture rate 24/1.001 Hz (2 _h) 24 Hz (3 _h) 25 Hz (5 _h) 30/1.001 Hz (6 _h) 30 Hz (7 _h) 50 Hz (9 _h) 60/1.001 Hz (A _h) 60 Hz (B _h) 100 Hz (D _h) 120/1.001 Hz (E _h) 120 Hz (F _h) Other values reserved	Sampling structure identification 4:2:2 (Y'C _B C _R ' or IC _T C _P) (0 _h) 4:4:4 (Y'C _B C _R ' or IC _T C _P) (1 _h) 4:4:4 (G'B'R') (2 _h) 4:2:0 (Y'C _B C _R ' or IC _T C _P) (3 _h)	Bit depth 10-bit full range (0 _h) 10-bit narrow range (1 _h) 12-bit narrow range (2 _h) 12-bit full range (3 _h)
b2	1			
b1	4K/8K Reserved (0 _h) 4K (1 _h) 8K (2 _h) Reserved (3 _h)			
b0 (LSB)				

NOTE 1 – EP = Even parity for b0 through b7.

3.8 Blanking data

The blanking data words occurring during blanking intervals that are not used for the timing reference codes (SAV and EAV), line number data, error detection codes or ancillary data should be set as listed below.

- (1) Basic streams for colour components Y', G', B', R': 100_h
- (2) Basic streams for colour components C'_B, C'_R: 800_h

4 Generation of 10G link signals

4.1 Generating 10G link signals from basic streams

4.1.1 Generating 10G link signals from 120, 120/1.001 or 100 Hz basic streams

The method for converting two 120, 120/1.001 or 100 Hz basic stream to one 10G link signal should be as shown in Figs. 2-13 to 2-16.

First, two basic streams should be multiplexed word-by-word and converted to a multiplexed data stream. Stuffing data should be added to the two basic streams as shown in Fig. 2-13. This results in a data stream that has 5280 words per line period for a frame frequency of 120 Hz and 120/1.001 Hz, or 6336 words per line period for a frame frequency of 100 Hz. That stuffing data, should be reserved and filled with 100_h.

FIGURE 2-13

Multiplexing of two 120, 120/1.001 or 100 Hz basic streams

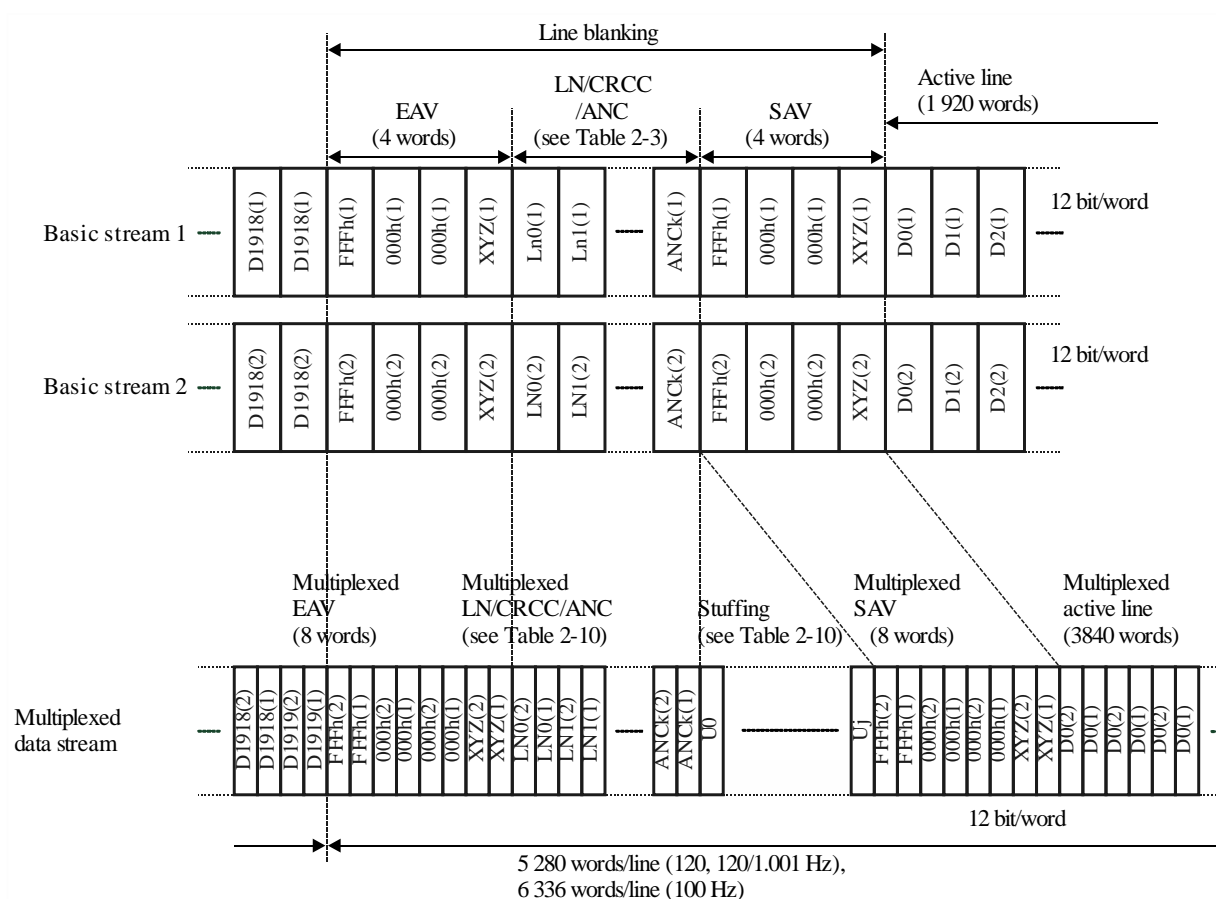

BT.2077-02-13

TABLE 2-10

Line structure of a 120, 120/1.001 or 100 Hz multiplexed data stream

Item	Number of data words	
	120 or 120/1.001 Hz frame frequency	100 Hz frame frequency
Multiplexed EAV	8	
Multiplexed LN/CRCC/ANC	544	1 424
Stuffing data	880	1 056
Multiplexed SAV	8	
Multiplexed active video	3 840	
Total word for a line	5 280	6 336

Next, the word-multiplexed data stream should be coded by 8B/10B encoding as specified by ANSI INCITS 230.

The multiplexed data stream consisting of 12-bit words should be first converted to a byte series as shown in Fig. 2-14, and then coded as 8B/10B encoded data. The conversion to byte series should be done in order from the beginning of the active line and every two words (Fig. 2-15). When doing the

8B/10B coding, the first four bytes of the multiplexed SAV and EAV should be replaced with a synchronization block (Fig. 2-16). The first two words of the multiplexed SAV should be replaced with the K28.5 special characters and those of the multiplexed EAV should be replaced with the K29.7 special characters defined by ANSI INCITS 230, and the successive two words should be replaced with content IDs. The content ID bit assignment should be as shown in Table 2-11 and the bit assignment of the system ID, which is part of the content ID, should be as shown in Table 2-12. The 8B/10B encoding process should start at the first K28.5 special character with a negative running disparity. The 8B/10B encoding process should be done in accordance with current running disparity at all the lines that follow.

The 8B/10B encoding converts two 12-bit words of data to three 10-bit words. The word-multiplexed data stream has 7 920 words per line period (10 bit/word) for the 120 Hz and 120/1.001 Hz frame frequencies and 9 504 words (10 bits/word) per line period for the 100 Hz frame frequency.

FIGURE 2-14

8B/10B encoding of multiplexed data stream

FIGURE 2-15

Data alignment and 8B/10B encoding of 2-word data block

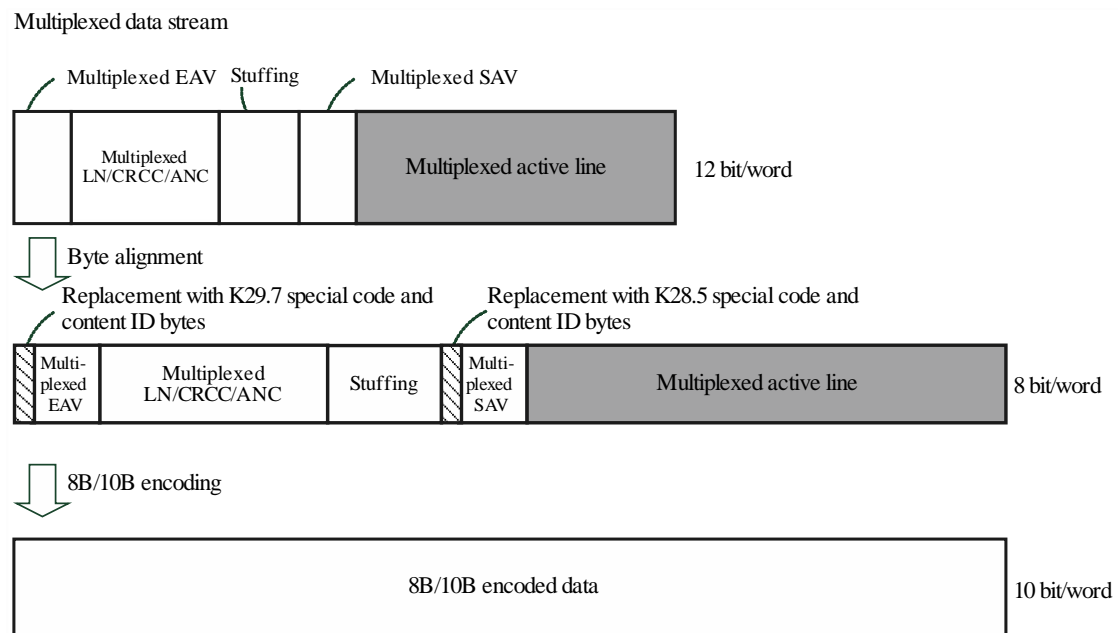
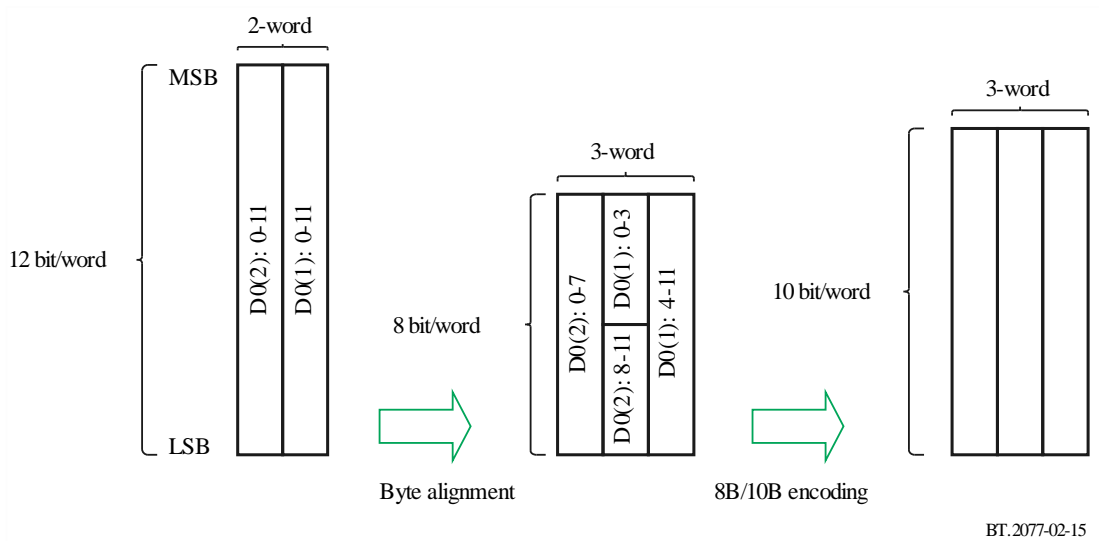

FIGURE 2-16

Multiplexed SAV and EAV data replacement with synchronization block (120, 120/1.001 or 100 Hz)

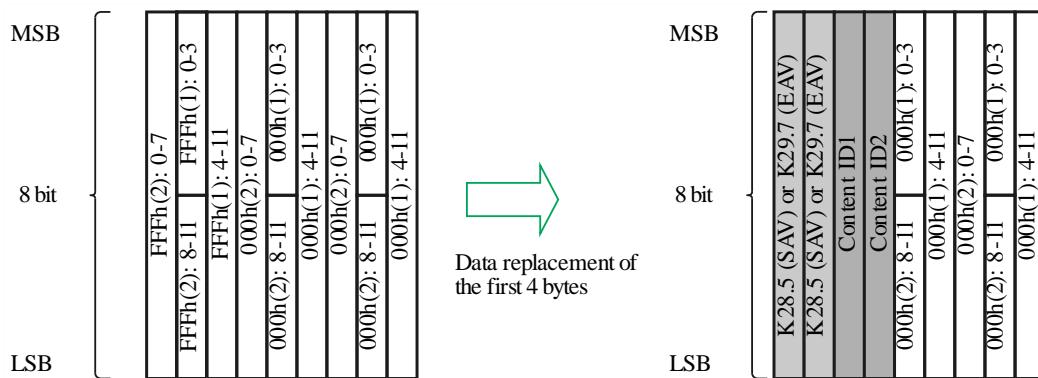

TABLE 2-11

Content ID bit assignment

Bit	Content ID1	Content ID2
b7 (MSB)	Reserved (0 _h)	Reserved (0 _h)
b6		
b5	System ID	10G link assignment Ch1 (00 _h) to Ch24 (17 _h)
b4		
b3		
b2		
b1		
b0 (LSB)		

TABLE 2-12

System ID bit assignment

System ID (b5 to b0)	System number	System ID (b5 to b0)	System number	System ID (b5 to b0)	System number	System ID (b5 to b0)	System number
000000	U1.1	001111	U1.16	100000	U2.1	101111	U2.16
000001	U1.2	010000	U1.17	100001	U2.2	110000	U2.17
000010	U1.3	010001	U1.18	100010	U2.3	110001	U2.18
000011	U1.4	010010	U1.19	100011	U2.4	110010	U2.19
000100	U1.5	010011	U1.20	100100	U2.5	110011	U2.20
000101	U1.6	010100	U1.21	100101	U2.6	110100	U2.21
000110	U1.7	010101	U1.22	100110	U2.7	110101	U2.22
000111	U1.8	010110	U1.23	100111	U2.8	110110	U2.23
001000	U1.9	010111	U1.24	101000	U2.9	110111	U2.24
001001	U1.10	011000	U1.25	101001	U2.10	111000	U2.25
001010	U1.11	011001	U1.26	101010	U2.11	111001	U2.26
001011	U1.12	011010	U1.27	101011	U2.12	111010	U2.27
001100	U1.13	011011	U1.28	101100	U2.13	111011	U2.28
001101	U1.14	011100	Reserved	101101	U2.14	111100	Reserved
001110	U1.15	~ 011111		101110	U2.15	~ 111111	

Next, the 8B/10B coded data should be serialized in order from the LSB into the serial stream of 10G link signal. The speed of the 10G link signals generated as described above for 120 Hz frame frequency is $7\,920$ (words/line) \times 10 (bits/word) \times $1\,125$ (lines) \times 120 (1/second), or 10.692 Gbit/s. For the frame frequency of 120/1.001 Hz, the speed is $7\,920$ (words/line) \times 10 (bits/word) \times $1\,125$ (lines) \times $120/1.001$ (1/second), or 10.692/1.001 Gbit/s. For the frame frequency of 100 Hz, the speed is $9\,504$ (words/line) \times 10 (bits/word) \times $1\,125$ (lines) \times 100 (1/seconds), or 10.692 Gbit/s.

4.1.2 Generating 10G link signals from 60, 60/1.001 or 50 Hz basic streams

The method for converting four 60, 60/1.001 or 50 Hz basic streams to one 10G link signal should be as shown in Figs. 2-17 and 2-18. First, the four basic streams should be converted to a word-multiplexed data stream by multiplexing word by word. Stuffing data should be added to the four basic streams as shown in Fig. 2-17. This results in a data stream that has 10 560 words per line period for a frame frequency of 60 Hz or 60/1.001 Hz, or 12 672 words per line period for a frame frequency of 50 Hz. The stuffing data should be reserved and filled with 100_h.

FIGURE 2-17

Multiplexing of four 60, 60/1.001 or 50 Hz basic streams

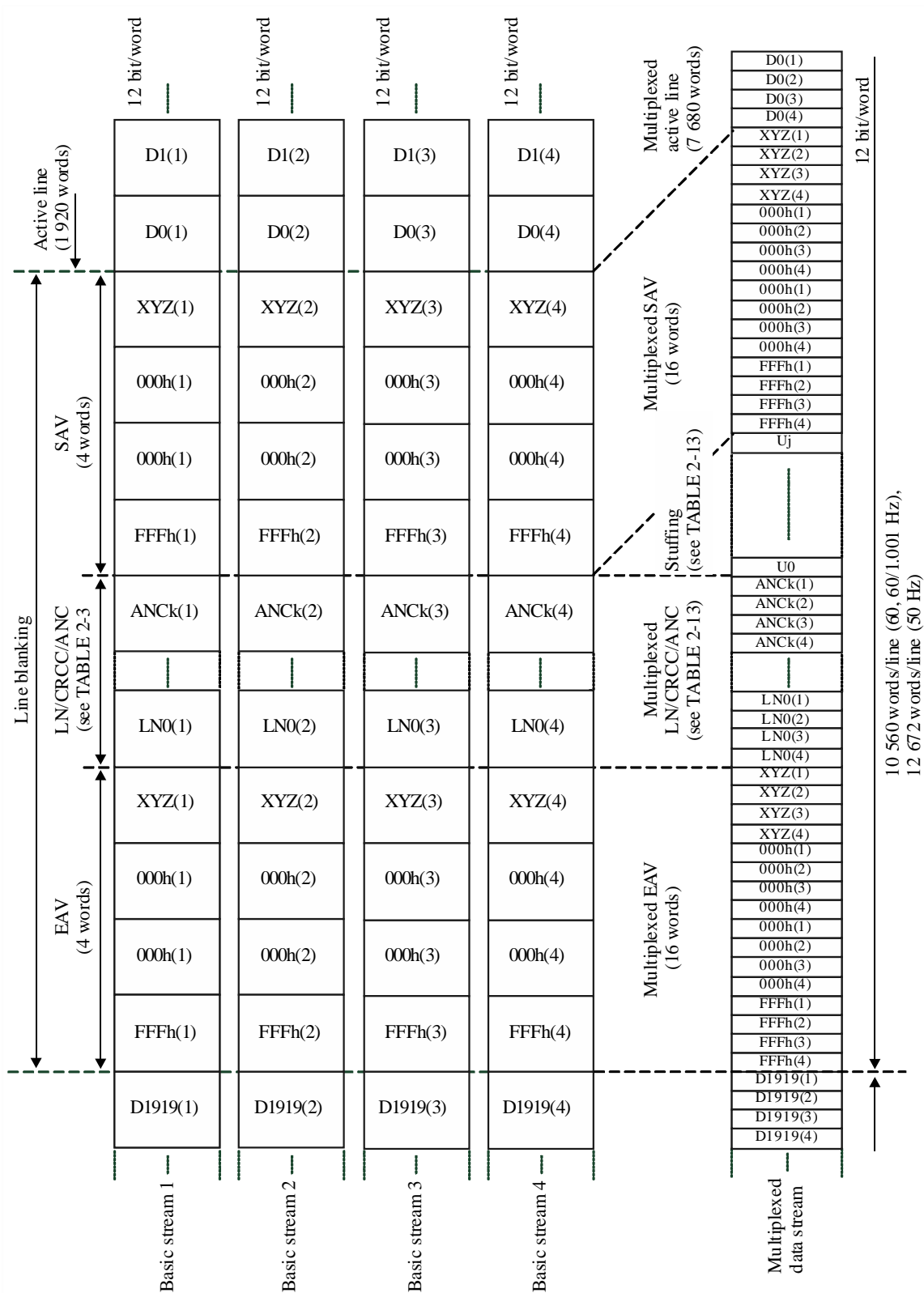

TABLE 2-13

Line structure of a 60, 60/1.001 or 50 Hz multiplexed data stream

Item	Number of data words	
	60 or 60/1.001 Hz frame frequency	50 Hz frame frequency
Multiplexed EAV	16	
Multiplexed LN/CRCC/ANC	1088	2848
Stuffing data	1760	2112
Multiplexed SAV	16	
Multiplexed active video	7680	
Total word for a line	10560	12672

Next, the word-multiplexed data stream should be coded by 8B/10B encoding as specified by ANSI INCITS 230.

The multiplexed data stream consisting of 12-bit words should be first converted to a byte series and then coded as 8B/10B encoded data. The conversion to byte series should be done in order from the beginning of the active data D0(4) and every two words in the same way as shown in Fig. 2-15. When doing the 8B/10B encoding, the first four bytes of the multiplexed SAV and EAV should be converted to a synchronization block as shown in Fig. 2-18. The first two words of the multiplexed SAV should be replaced with the K28.5 special characters and those of the multiplexed EAV should be replaced with the K29.7 special characters defined by ANSI INCITS 230, and the successive two words should be replaced with content IDs. The content ID bit assignment should be as shown in Tables 2-11 and 2-12. The 8B/10B encoding process should start at the first K28.5 special character with a negative running disparity. The 8B/10B encoding process should be done in accordance with current running disparity at all the lines that follow.

The 8B/10B encoding converts two 12-bit words of data to three 10-bit words. The word-multiplexed data stream has 15840 words (10 bits/word) per line period for the 60 Hz and 60/1.001 Hz frame frequencies and 19008 words (10 bits/word) per line period for the 50 Hz frame frequency.

FIGURE 2-18

Multiplexed SAV and EAV data replacement with synchronization block (60, 60/1.001 or 50 Hz)

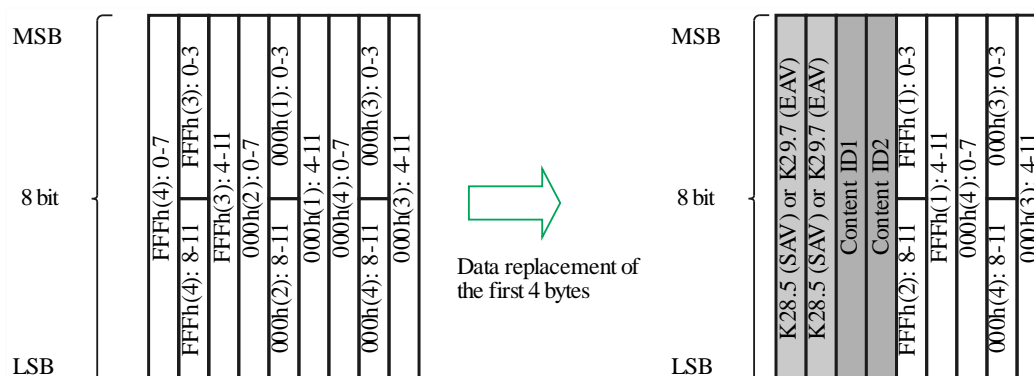

Next, the 8B/10B coded data should be serialized in order from the LSB into the serial stream of 10G link signal. The speed of the 10G link signals generated as described above for the 60 Hz frame frequency is $15\,840$ (words/line) \times 10 (bits/word) \times $1\,125$ (lines) \times 60 (1/seconds), or 10.692 Gbit/s. For the frame frequency of 60/1.001 Hz, the speed is $15\,840$ (words/line) \times 10 (bits/word) \times $1\,125$ (lines) \times $60/1.001$ (1/second), or 10.692/1.001 Gbit/s. For the frame frequency of 50 Hz, the speed is $19\,008$ (words/line) \times 10 (bits/word) \times $1\,125$ (lines) \times 50 (1/seconds), or 10.692 Gbit/s.

4.1.3 Generating 10G link signals from 30, 30/1.001, 25, 24 or 24/1.001 Hz basic streams

The method for converting eight 30, 30/1.001, 25, 24 or 24/1.001 Hz basic streams to one 10G link signal should be as shown in Figs. 2-19 and 2-20. First, the eight 30 Hz basic streams should be converted to a word-multiplexed data stream by multiplexing word by word. Stuffing data should be added to the eight basic streams as shown in Fig. 2-19. This results in a data stream that has 21 120 words for a frame frequency of 30 Hz or 30/1.001 Hz, 25 344 words for a frame frequency of 25 Hz, and 26 400 words for a frame frequency of 24 Hz or 24/1.001 Hz. The stuffing data should be reserved and filled with 100_h.

FIGURE 2-19

Multiplexing of eight 30, 30/1.001, 24 or 24/1.001 Hz basic streams

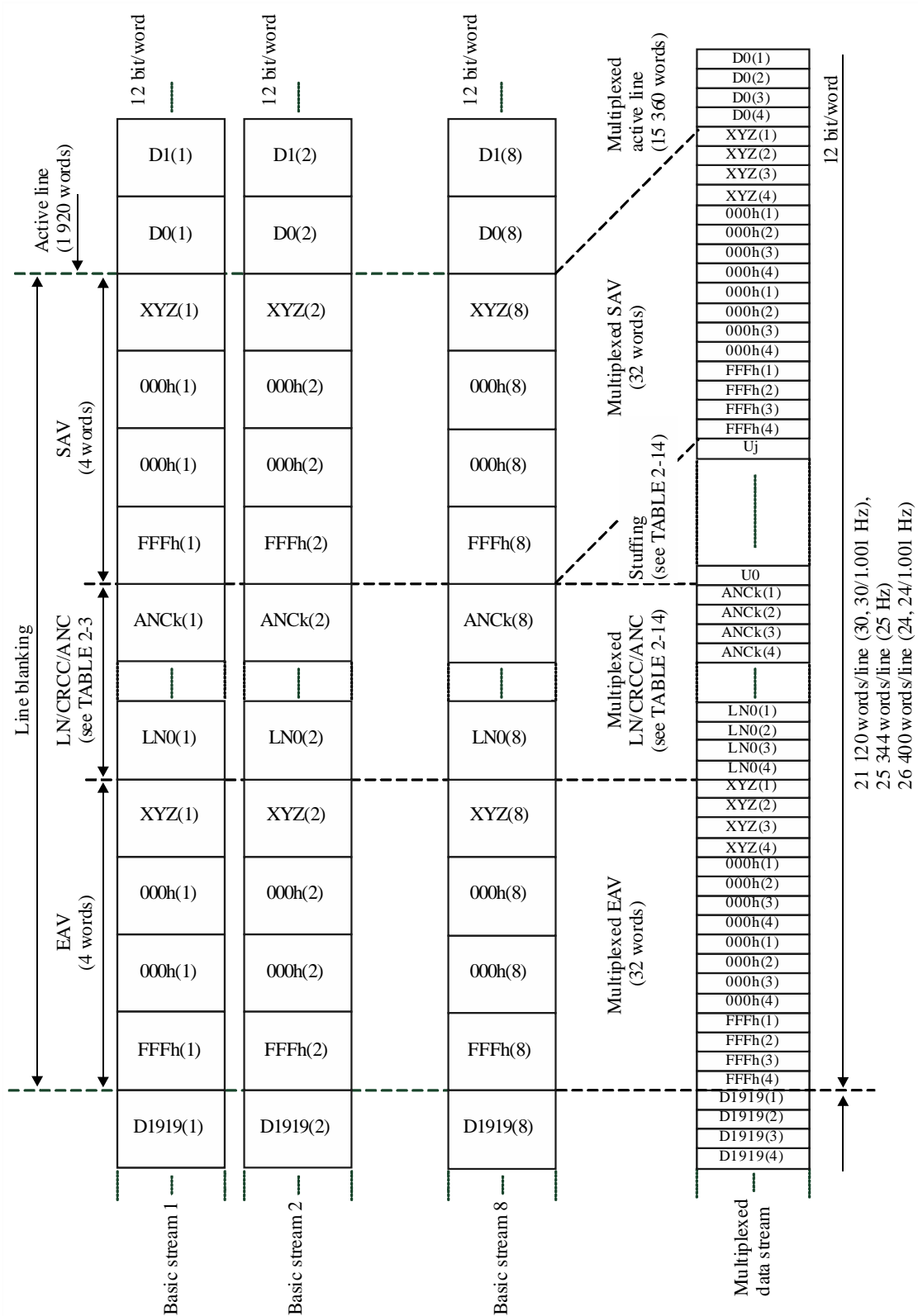

TABLE 2-14

Line structure of a 30, 30/1.001, 25, 24 or 24/1.001 Hz multiplexed data stream

Item	Number of data words		
	30 or 30/1.001 Hz frame frequency	25 Hz frame frequency	24 or 24/1.001 Hz frame frequency
Multiplexed EAV	32		
Multiplexed LN/CRCC/ANC	2 176	5 696	6 576
Stuffing data	3 520	4 224	4 400
Multiplexed SAV	32		
Multiplexed active video	15 360		
Total data words per line	21 120	25 344	26 400

Next, the word-multiplexed data stream should be coded by 8B/10B encoding as specified by ANSI INCITS 230.

The multiplexed data stream consisting of 12-bit words should be first converted to a byte series and then coded as 8B/10B encoded data. The conversion to byte series should be done in order from the beginning of the active data D0(8) and every two words, in the same way as shown in Fig. 2-15. When doing the 8B/10B encoding, the first four bytes of the multiplexed SAV and EAV should be converted to a synchronization block as shown in Fig. 2-20. The first two words of the multiplexed SAV should be replaced with the K28.5 special characters and those of the multiplexed EAV should be replaced with the K29.7 special character defined by ANSI INCITS 230, and the successive two words should be replaced with content IDs. The content ID bit assignment should be as shown in Tables 2-11 and 2-12. The 8B/10B encoding process should start at the first K28.5 special character with a negative running disparity. The 8B/10B encoding process should be done in accordance with current running disparity at all the lines that follow.

The 8B/10B encoding converts two 12-bit words of data to three 10-bit words. The word-multiplexed data stream has 31 680 words (10 bits/word) per line for frame frequencies of 30 Hz and 30/1.001 Hz, 38 016 words (10 bits/word) per line for a frame frequency of 25 Hz, and 39 600 words (10 bits/word) per line for frame frequencies of 24 and 24/1.001 Hz.

FIGURE 2-20

Multiplexed SAV and EAV data replacement with synchronization block (30, 30/1.001, 25, 24 or 24/1.001 Hz)

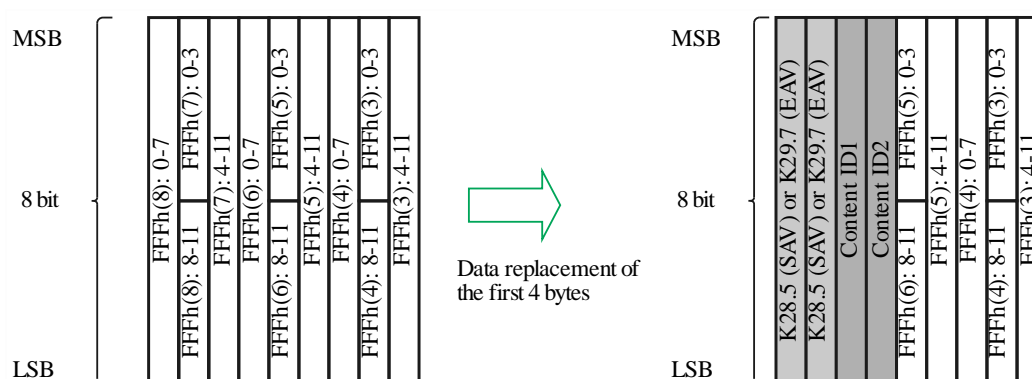

BT.2077-02-20

The 8B/10B coded data should be serialized in order from the LSB into the serial stream of 10G link signal. The speed of the 10G link signals generated as described above for the 30 Hz frame frequency is 31 680 (words/line) \times 10 (bits/word) \times 1 125 (lines) \times 30 (1/seconds), or 10.692 Gbit/s. For the frame frequency of 30/1.001 Hz, the speed is 31 680 (words/line) \times 10 (bits/word) \times 1 125 (lines) \times 30/1.001 (1/second), or 10.692/1.001 Gbit/s. For the frame frequency of 25 Hz, the speed is 38 016 (words/line) \times 10 (bits/word) \times 1 125 (lines) \times 25 (1/second), or 10.692 Gbit/s. For the frame frequency of 24 Hz, the speed is 39 600 (words/line) \times 10 (bits/word) \times 1 125 (lines) \times 24 (1/second), or 10.692 Gbit/s. For the frame frequency of 24/1.001 Hz, the speed is 39 600 (words/line) \times 10 (bits/word) \times 1 125 (lines) \times 24/1.001 (1/second), or 10.692/1.001 Gbit/s.

4.2 Mapping of 8K or 4K image to 10G link signals

4.2.1 8K/ Fr ($Fr = 120, 120/1.001, 100$)

The mapping of the 8K/ Fr ($Fr = 120, 120/1.001, 100$) images listed below to the 10G link signals should be as illustrated in Figs. 2-21 and 2-22.

- U2.1, U2.2 (8K/ Fr , G'B'R', 4:4:4);
- U2.8, U2.9 (8K/ Fr , Y'C_BC_R, 4:4:4);
- U2.15, U2.16 (8K/ Fr , Y'C_BC_R, 4:2:2);
- U2.22, U2.23 (8K/ Fr , Y'C_BC_R, 4:2:0).

The S_Ip.q (p is an integer greater than or equal to 1 and less than or equal to 4; q is an integer greater than or equal to 1 and less than or equal to 3) represents the 4K sub-image p for colour component C_q generated by division of the 8K images and should be mapped as shown in Fig. 2-8. The B_Iu.p.q (u is an integer greater than or equal to 1 and less than or equal to 4) represents the basic image u generated by further division of 4Ks/ Fr S_Ip.q and should be mapped as shown in Fig. 2-9. BS1/ Fr and BS2/ Fr respectively represents the Fr Hz basic stream 1 and Fr Hz basic stream 2 specified in Fig. 2-13. For the 8K/ Fr mapping, one 10 GHz link signal should be generated from the two Fr Hz basic streams. As shown in Fig. 2-7, fewer 4K sub-images should be generated from the 8K image for 4:2:2 or 4:2:0 (both Y'C_BC_R) than for 4:4:4 (G'B'R' or Y'C_BC_R). In Fig. 2-21, the 4K sub-images that are appended with *1 should be generated with 4:4:4 and 4:2:2, and those appended with *2 should be generated with only 4:4:4.

FIGURE 2-21

Mapping to 10G links for 8K/*Fr* (*Fr* = 120, 120/1.001, 100) with 4:4:4(*G'B'R'* or *Y'C'_BC'_R*) or 4:2:2 (*Y'C'_BC'_R*)

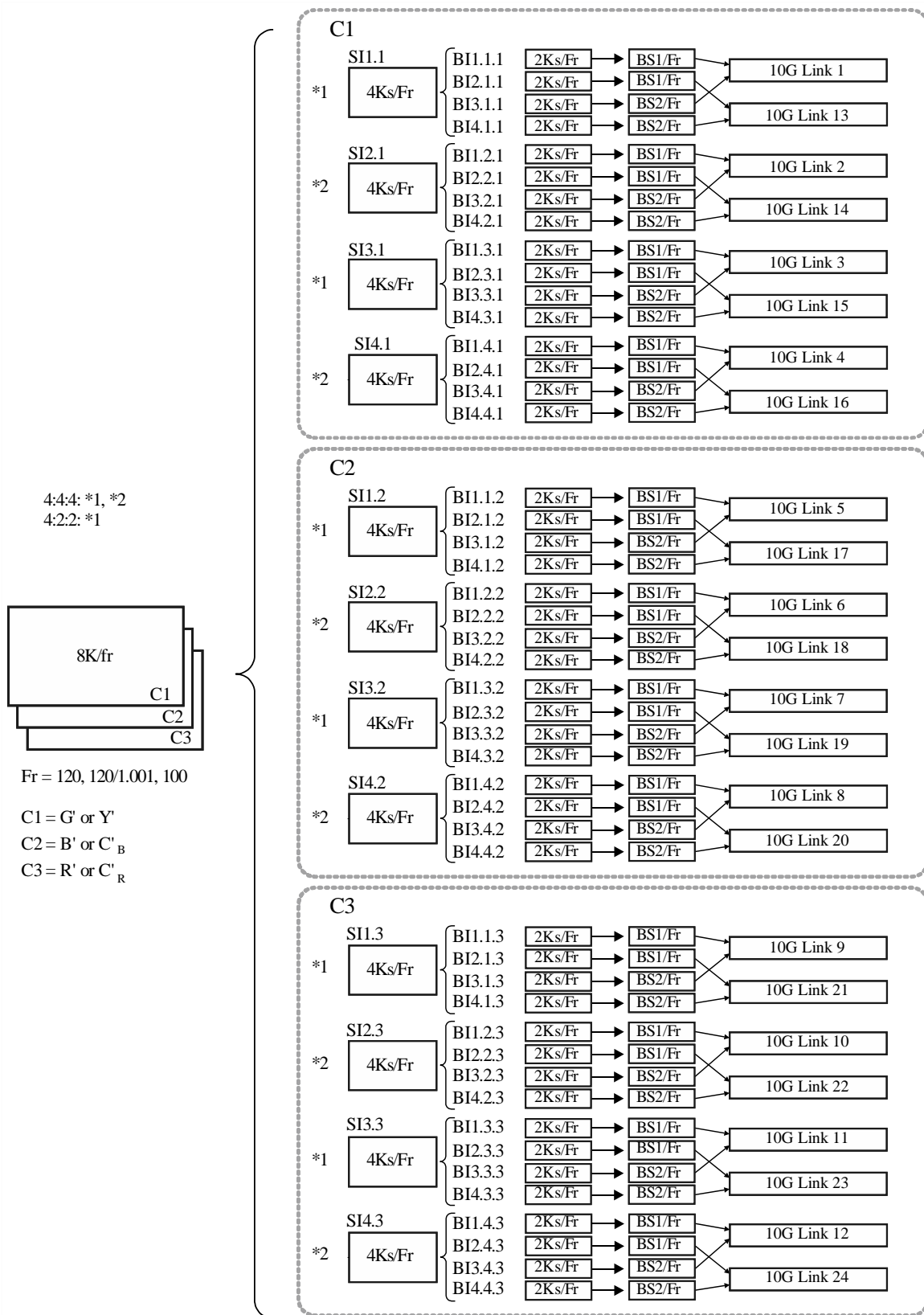
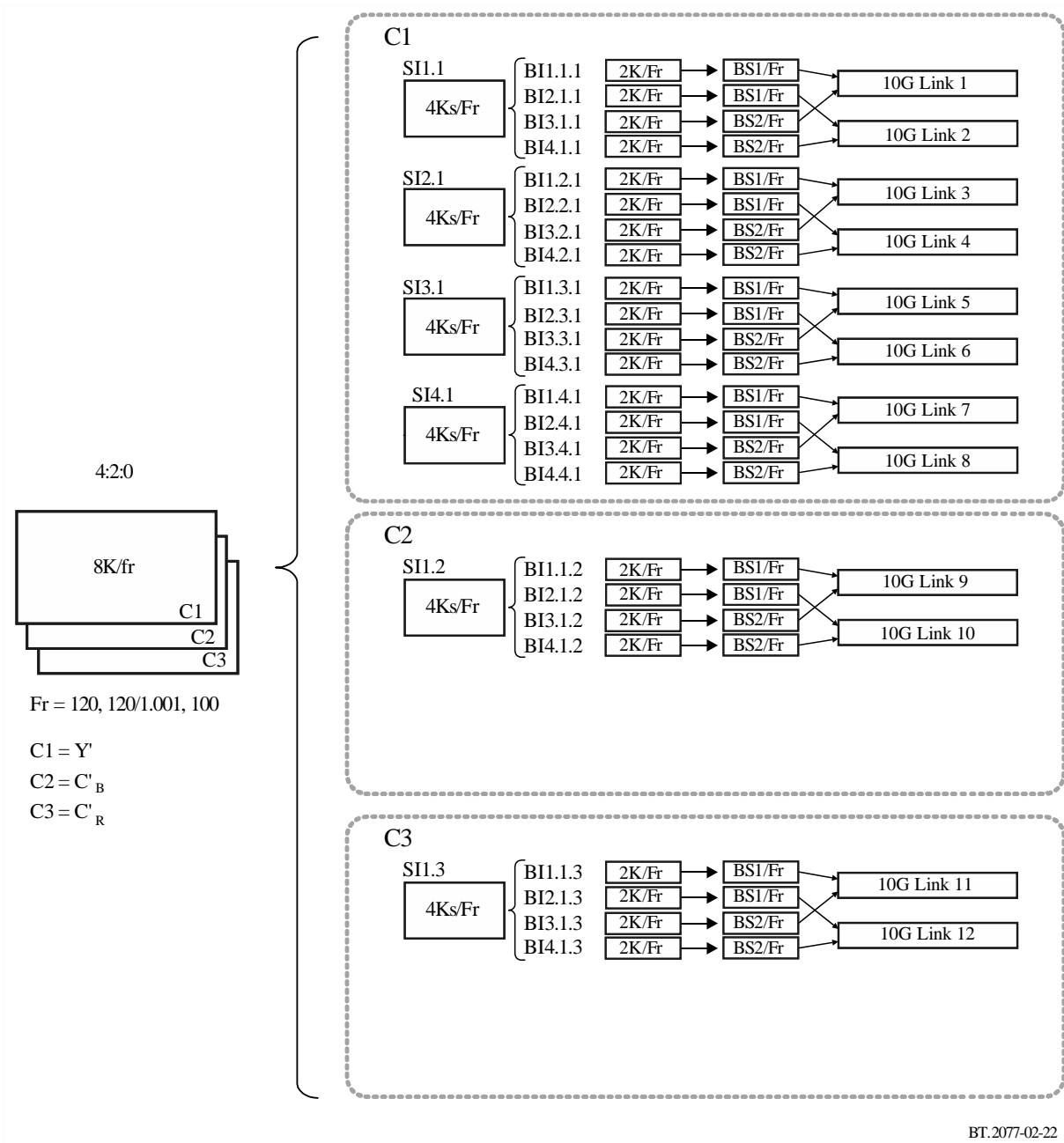

FIGURE 2-22

Mapping to 10G links for 8K/*Fr* (*Fr* = 120, 120/1.001, 100) with 4:2:0 (*Y'C'B'R*)



4.2.2 8K/ Fr ($Fr = 60, 60/1.001, 50$)

The mapping of the 8K/ Fr ($Fr = 60, 60/1.001, 50$) images listed below to the 10G link signals should be as illustrated in Fig. 2-23.

- U2.3, U2.4 (8K/ Fr , G'B'R', 4:4:4);
- U2.10, U2.11 (8K/ Fr , Y'C_BC_R', 4:4:4);
- U2.17, U2.18 (8K/ Fr , Y'C_BC_R', 4:2:2);
- U2.24, U2.25 (8K/ Fr , Y'C_BC_R', 4:2:0).

S_{Ip.q} and B_{Iu.p.q} are as defined in § 4.2.1. BS1/ Fr to BS4/ Fr respectively represents the Fr Hz basic streams 1 to 4 specified in Fig. 2-17. For the 8K mapping, one 10 GHz link signal should be generated for each four basic streams. In Fig. 2-23, the 10G link signals that are appended with *1 should be generated with the entire 8K sampling structure, those appended with *2 are generated with only 4:4:4 and 4:2:2, and those appended with *3 should be generated with only 4:4:4.

FIGURE 2-23

Mapping to 10G links for 8K/*Fr* (*Fr* = 60, 60/1.001, 50)

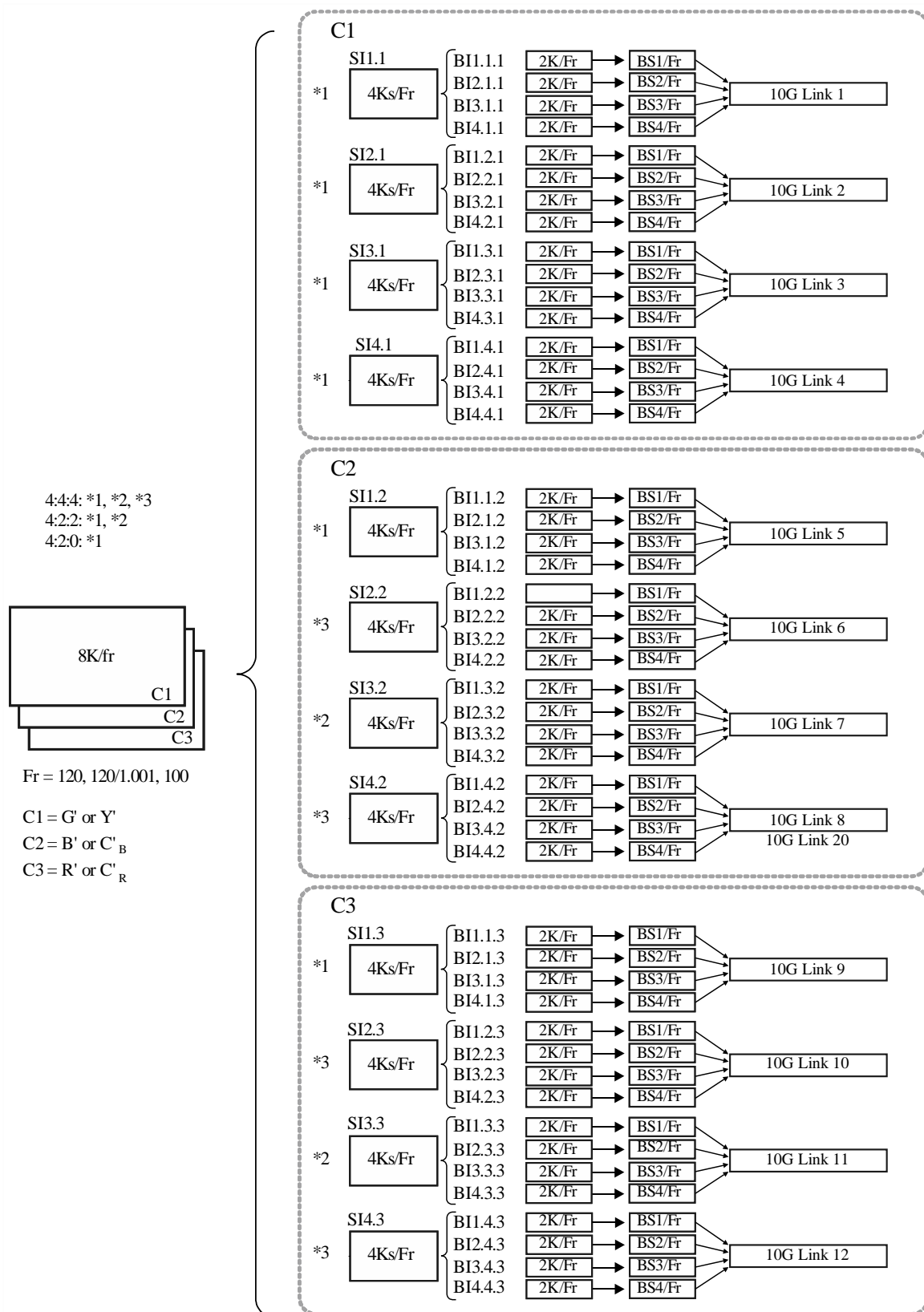

4.2.3 8K/ Fr ($Fr = 30, 30/1.001, 25, 24, 24/1.001$)

The mapping of the 8K/ Fr ($Fr = 30, 30/1.001, 25, 24, 24/1.001$) images listed below to the 10G link signals should be as illustrated in Fig. 2-24.

- U2.5, U2.6, U2.7 (8K/ Fr , G'B'R', 4:4:4);
- U2.12, U2.13, U2.14 (8K/ Fr , Y'C_BC_R', 4:4:4);
- U2.19, U2.20, U2.21 (8K/ Fr , Y'C_BC_R', 4:2:2);
- U2.26, U2.27, U2.28 (8K/ Fr , Y'C_BC_R', 4:2:0).

S_{Ip}.q and B_{Iu}.p.q are as defined in § 4.2.1. BS1/ Fr to BS8/ Fr respectively represents the Fr Hz basic streams 1 to 8 specified in Fig. 2-19. For the 8K/ Fr mapping, one 10 GHz link signal should be generated for each eight basic streams. In Fig. 2-24, the 4K sub-images that are appended with *1 should be generated with the entire 8K sampling structure, those appended with *2 should be generated with only 4:4:4 and 4:2:2, and those appended with *3 are generated with only 4:4:4.

For the 4:2:0 case, the 4K sub-images appended with *2 should not be generated, so the number of basic streams generated from the 4K sub-images of the C_B' and C_R' colour components that are appended with *1 are less than eight. For that case, basic streams should be generated from basic images for which the 12-bit data of the entire sample is 800h, and those streams should be assigned to BS5/ Fr , BS6/ Fr , BS7/ Fr , and BS8/ Fr to generate the 10G link signal.

FIGURE 2-24

Mapping to 10G links for 8K/*Fr* (*Fr* = 30, 30/1.001, 25, 24, 24/1.001)

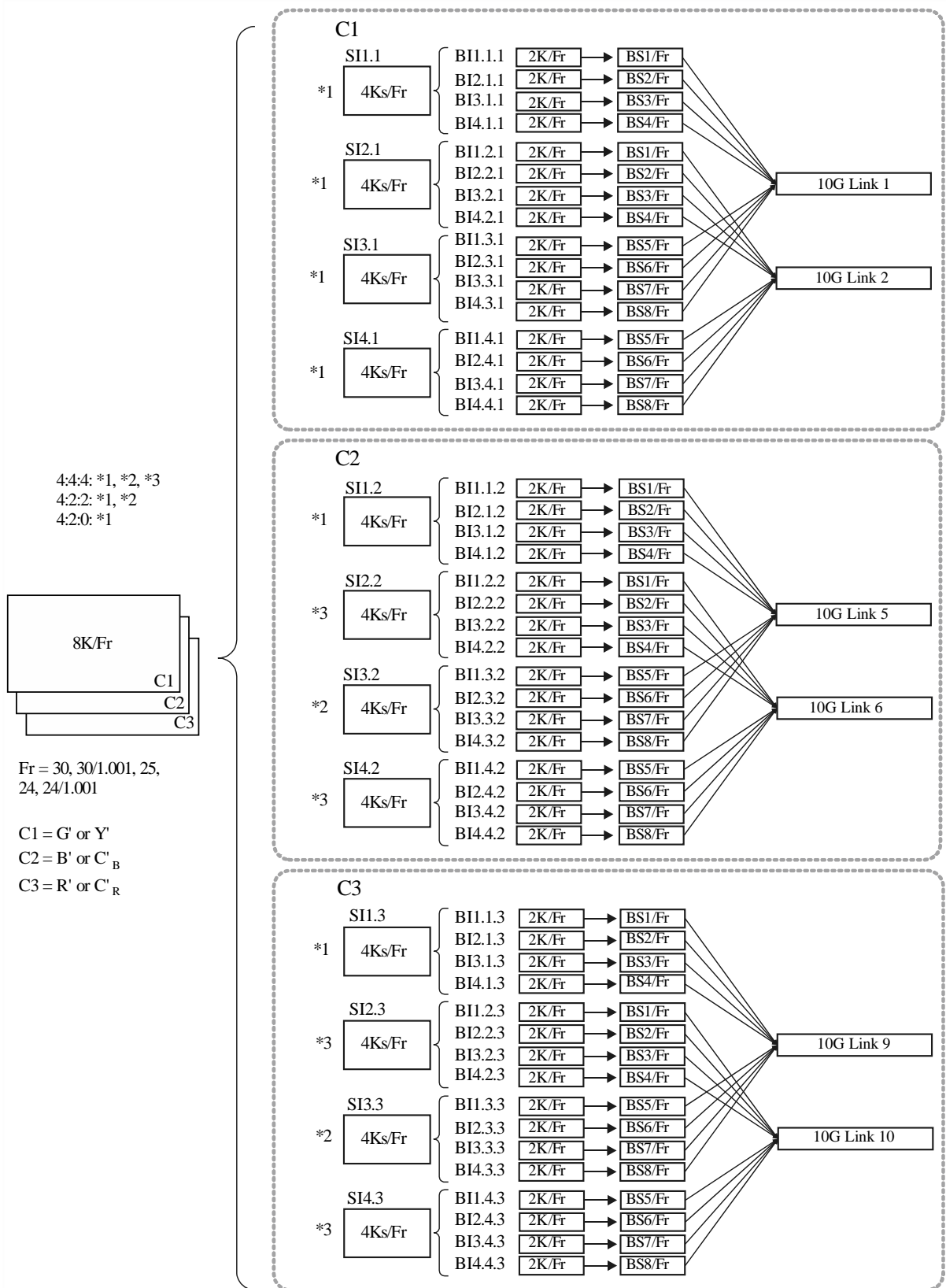

4.2.4 4K/ Fr ($Fr = 120, 120/1.001, 100$)

The mapping of the 4K/ Fr ($Fr = 120, 120/1.001, 100$) images listed below to the 10G link signals should be as illustrated in Fig. 2-25.

- U1.1, U1.2 (4K/ Fr , G'B'R', 4:4:4);
- U1.8, U1.9 (4K/ Fr , Y'C_BC_R', 4:4:4);
- U1.15, U1.16 (4K/ Fr , Y'C_BC_R', 4:2:2);
- U1.22, U1.23 (4K/ Fr , Y'C_BC_R', 4:2:0).

The BU_u.q (u is an integer greater than or equal to 1 and less than or equal to 4; q is an integer greater than or equal to 1 and less than or equal to 3) represents basic image u for colour component C_q generated by dividing the 4K images and should be mapped as shown in Fig. 2-9. BS1/ Fr and BS2/ Fr represents the Fr Hz basic streams 1 and 2 that are defined in Fig. 2-13. For the 4K/ Fr mapping, one 10G link signal should be generated for each two Fr Hz basic streams.

For the case of 4:2:0, less than two Fr Hz basic streams should be generated from each C_B and C_R colour component of the 4K images. For that case, an Fr Hz basic stream should be generated from basic images for which the 12-bit data of the entire sample is 800h, and the stream should be assigned to BS2/ Fr to generate the 10G link signal.

FIGURE 2-25

Mapping to 10G links for 4K/*Fr* (*Fr* = 120, 120/1.001, 100)

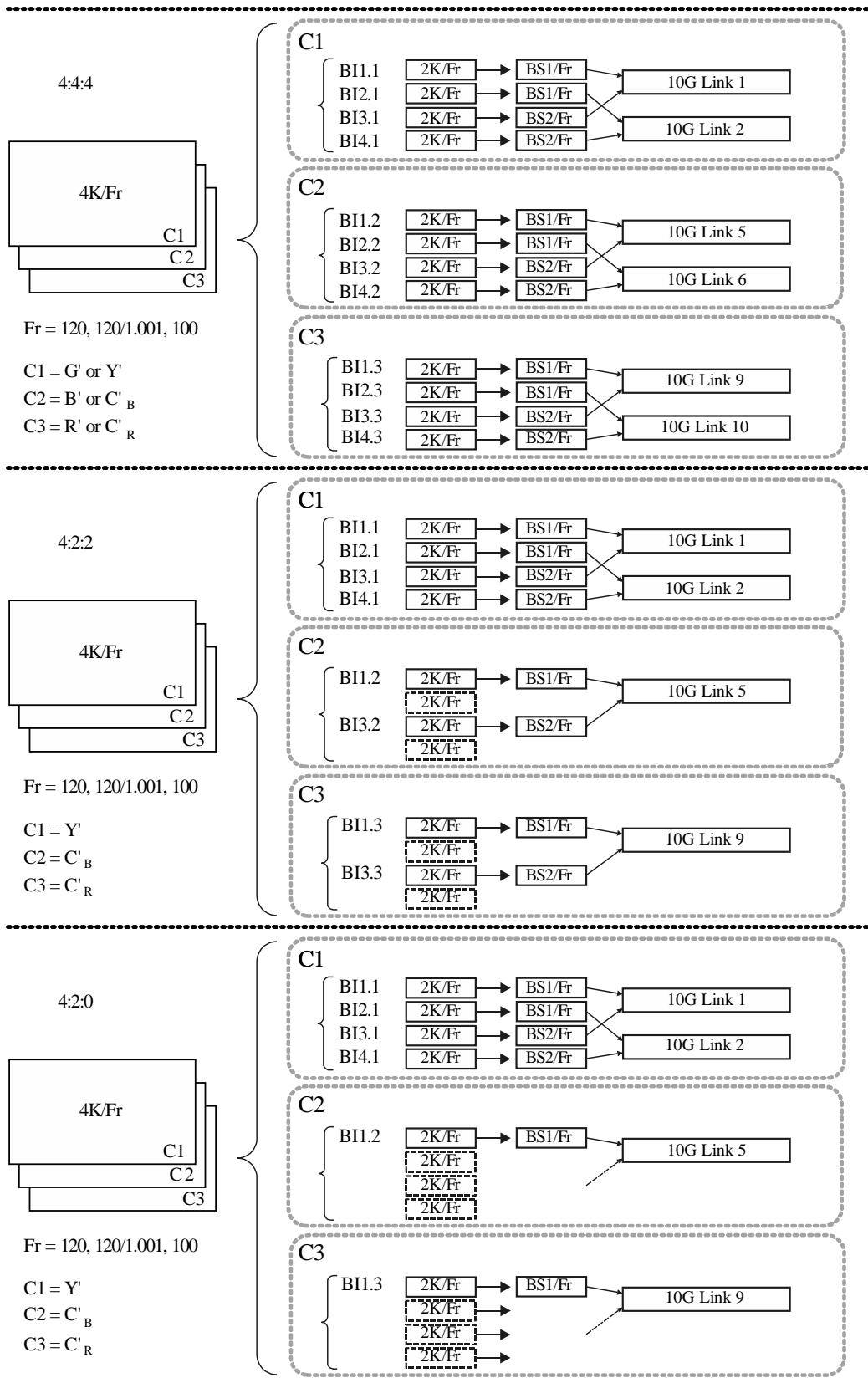

4.2.5 4K/ Fr ($Fr = 60, 60/1.001, 50$)

The mapping of the 4K/ Fr ($Fr = 60, 60/1.001, 50$) images listed below to the 10G link signals should be as illustrated in Fig. 2-26.

- U1.3, U1.4 (4K/ Fr , G'B'R', 4:4:4);
- U1.10, U1.11 (4K/ Fr , Y'C_BC_R', 4:4:4);
- U1.17, U1.18 (4K/ Fr , Y'C_BC_R', 4:2:2);
- U1.24, U1.25 (4K/ Fr , Y'C_BC_R', 4:2:0).

BIu.q is as defined in § 4.2.4. BS1/ Fr to BS4/ Fr respectively represents the Fr Hz basic stream 1 to 4 specified in Fig. 2-17. For the 4K mapping, one 10 GHz link signal should be generated for each four basic streams.

For the case of 4:2:2 and 4:2:0, less than four basic streams should be generated from the C_B and C_R colour components of the 4K images, so basic streams should be generated from basic images for which the 12-bit data of the entire sample is 800h, and those streams should be assigned to BS2/ Fr and BS4/ Fr for 4:2:2 and to BS2/ Fr , BS3/ Fr , and BS4/ Fr for 4:2:0 to generate the 10G link signal.

FIGURE 2-26

Mapping to 10G links for 4K/*Fr* (*Fr* = 60, 60/1.001, 50)

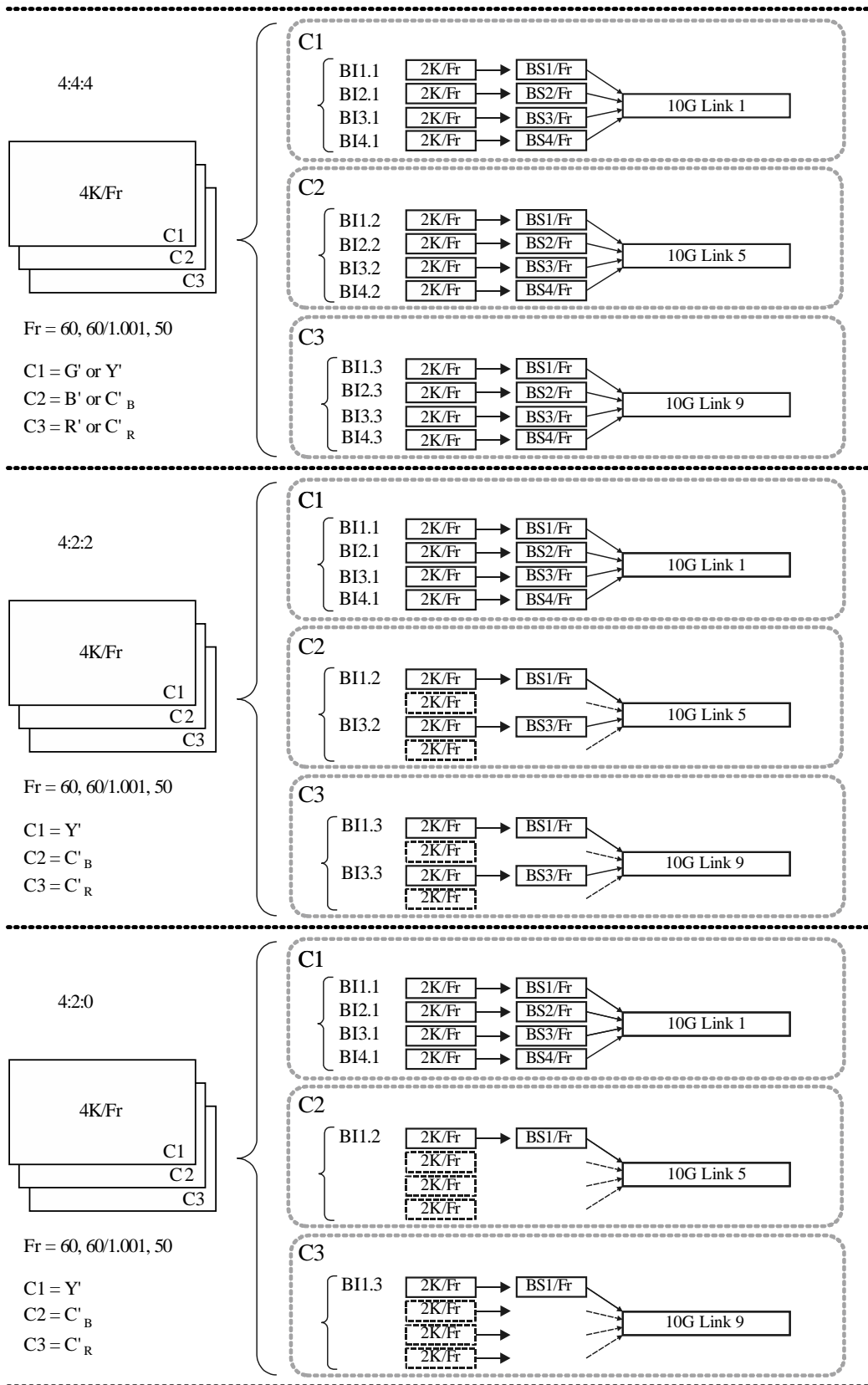

4.2.6 4K/ Fr ($Fr = 30, 30/1.001, 25, 24, 24/1.001$)

The mapping of the 4K/ Fr ($Fr = 30, 30/1.001, 25, 24, 24/1.001$) images listed below to the 10G link signals should be as illustrated in Fig. 2-27.

- U1.5, U1.6, U1.7 (4K/ Fr , G'B'R', 4:4:4);
- U1.12, U1.13, U1.14 (4K/ Fr , Y'C_BC_R', 4:4:4);
- U1.19, U1.20, U1.21 (4K/ Fr , Y'C_BC_R', 4:2:2);
- U1.26, U1.27, U1.28 (4K/ Fr , Y'C_BC_R', 4:2:0).

BIu.q is as defined in § 4.2.4. BS1/ Fr to BS4/ Fr respectively represents the Fr Hz basic streams 1 to 4 specified in Fig. 2-19. One 10 GHz link signal should be generated for each eight basic streams, but less than eight basic streams should be generated from the respective 4K colour components, so basic streams should be generated from basic images for which the 12-bit data of the entire sample is 100h for the colour components Y', G', B', and R' or 800h for C_B' and C_R' and assigned to the unassigned basic stream in Fig. 2-27 to generate the 10G link signal.

FIGURE 2-27

Mapping to 10G links for 4K/*Fr* (*Fr* = 30, 30/1.001, 25, 24, 24/1.001)

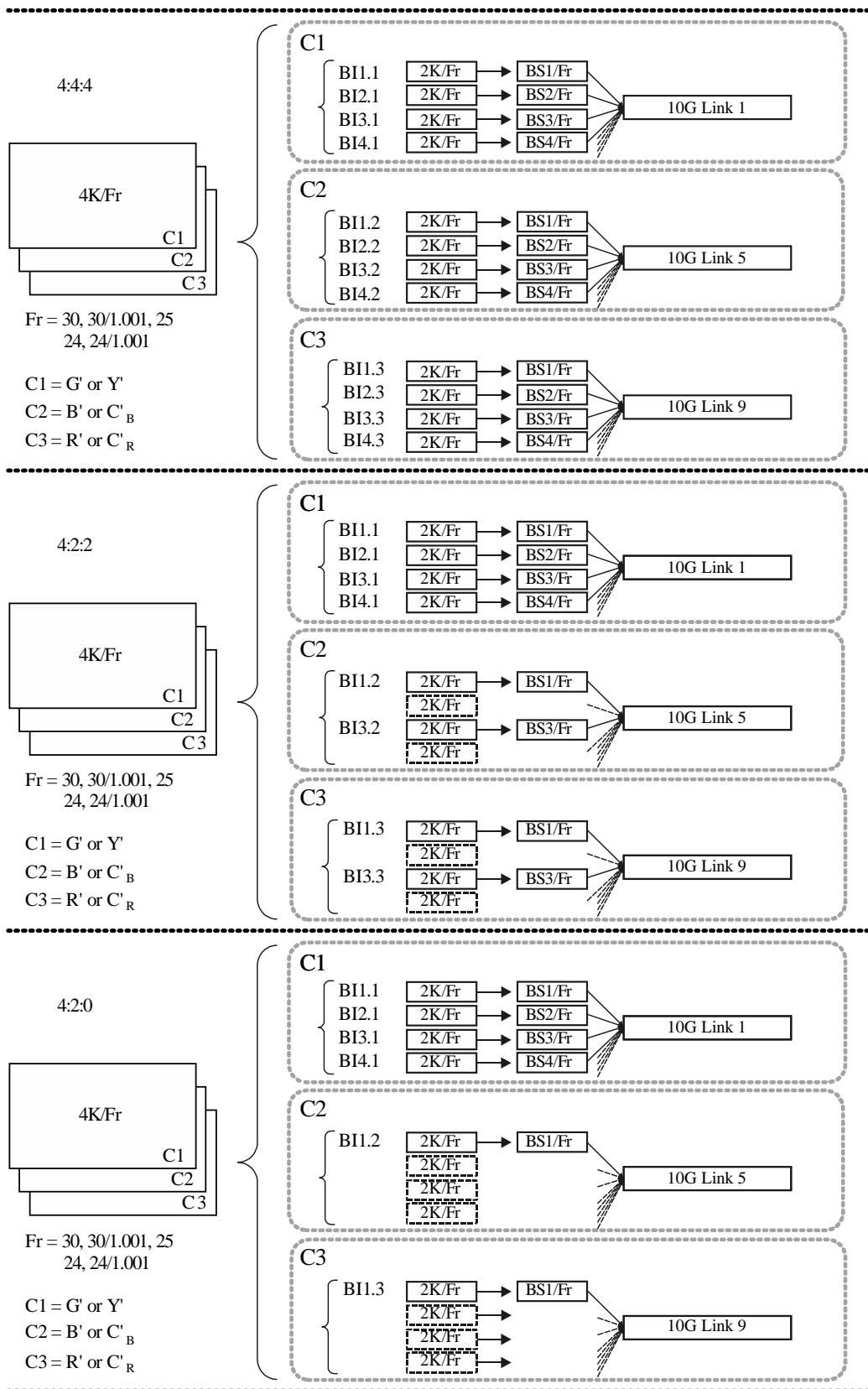

5 Physical layer

For a short haul interconnection, multi-mode fibre transmission specified in § 5.1 may be used. For a long haul interconnection, single mode fibre transmission utilizing dense wavelength division multiplexing (DWDM) specified in § 5.2 may be used. Specifications of multi-mode fibre and single mode fibre should be as defined in IEC 60793-2-10 and IEC 60793-2-50, respectively.

5.1 Physical layer specification for multi-mode fibre transmission

5.1.1 Optical transmitter characteristics

The optical transmitter characteristics of each 10 G link should be as shown in Table 2-15. In Figure 2-28, normalized amplitudes of 0 and 1 represent the amplitudes of logic ZERO and ONE respectively. These are defined by the means of the lower and upper halves of the central 0.2 UI of the eye.

A UI is the period of one clock cycle of a 10 G link signal. The eye pattern should be measured with respect to the mask of the eye using a receiver with a fourth-order Bessel-Thomson response with a 3 dB frequency of $0.75 \times 10.692 \text{ GHz} = 8 \text{ GHz}$.

TABLE 2-15

Optical transmitter characteristics

Optical Wavelength	840 nm to 860 nm
RMS spectral width (max) (Note 1)	0.65 nm
Signal rate	10.692 GBd \pm 10 ppm, or 10.692/1.001 GBd \pm 10 ppm
Average launch power (max) (Note 2)	+2.4 dBm
Average launch power (min) (Note 2)	-7.6 dBm
Extinction Ratio (min)	3 dB
Maximum reflected power	-12 dB
Output optical eye mask (Note 3)	See Fig. 2-28
Jitter	See § 5.1.3
Electrical/optical transfer function	Logic "1" = Higher optical power Logic "0" = Lower optical power

NOTE 1 – RMS spectral width is the standard deviation of the spectrum.

NOTE 2 – Power is the average power measured with an average-reading power meter.

NOTE 3 – One thousand accumulated waveforms are recommended for transmitter optical output eye mask compliance test.

FIGURE 2-28

Transmitter output optical eye mask

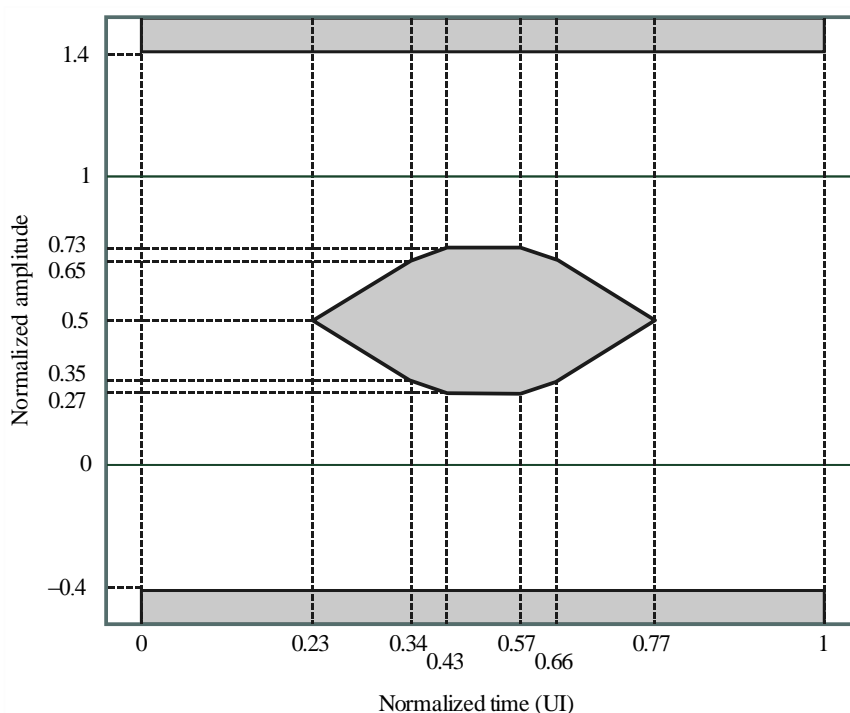

BT.2077-02-28

5.1.2 Optical receiver characteristics

Receiver characteristics of each 10 G link should be as shown in Table 2-16. Within the receiver input range a BER < 10⁻¹² should be achieved with colour bar test signals or PRBS-31 pattern (when testing system components with BER testers). A BER < 10⁻¹⁴ is recommended. Measurement for 5 minutes is recommended for verifying BER < 10⁻¹² when using BER-based test equipment.

NOTE – The PRBS-31 pattern generator is defined in IEEE 802.3ae-2002.

TABLE 2-16

Optical receiver characteristics

Average receive power (max) (Note 1)	+2.4 dBm
Average receive power (min) (Note 1)	-9.5 dBm
Detector damage threshold (min)	+3.4 dBm
Jitter	See § 5.1.3
Optical/electrical transfer function	Higher optical power = Logic “1” Lower optical power = Logic “0”

NOTE 1 – Power is the average power measured with an average-reading power meter.

5.1.3 Jitter specifications

Jitter specifications should be as shown in Table 2-17. Jitter is defined as the variation of a digital signal’s transitions from their ideal positions in time, and is specified as peak-to-peak quantities in

unit UI. Bandpass slopes of timing jitter and alignment jitter should be at least 20 dB/decade. Stop band rejections should be at least 20 dB. Pass band ripples should be less than ± 1 dB.

TABLE 2-17
Jitter specifications

Parameter	Value	Description
F1	10 Hz	Low-frequency specification limit
F2	20 kHz	Upper band edge for A1
F3	4 MHz	Lower band edge for A2
F4	> 1/10 the clock rate	High-frequency specification limit
A1	10 UI	Timing jitter: Sinusoidal jitter amplitude should be less than $2 \times 10^5/f + 0.1$ UI at $20 \text{ kHz} < f \leq 4 \text{ MHz}$.
A2	0.15 UI	Alignment jitter: Sinusoidal jitter amplitude should be less than 0.15 UI at $f > 4 \text{ MHz}$.
Error Criterion	BER = 10^{-12}	Criterion for onset of errors
Test signal	PRBS-31 or Colour bar	Data rate of PRBS-31 should be 10.692 Gbit/s or 10.692/1.001 Gbit/s

NOTE – See ITU-R BT.1363-1 for definition of jitter terms.

5.1.4 Timing difference

The timing difference between 10G link signals should not exceed 400 ns.

5.1.5 Optical connector

The optical connector characteristics should be as shown in Table 2-18. A receptacle connector with equipment should be as shown in Fig. 2-29 and the dimensions of the receptacle should be as shown in Table 2-19. A geometric array of the 24 fibres for the receptacle connector should comply with IEC 61754-7.

TABLE 2-18
Optical connector characteristics

Number of fibres	24
Fibre type	Multi-mode fibre
Connection loss	Less than 0.75 dB
Insertion/withdrawals	More than 5000 times
Equilibrium tensile loading of connectors	250 N
Other requirements	Lock mechanism Dustproof structure

FIGURE 2-29
 Receptacle connector with equipment

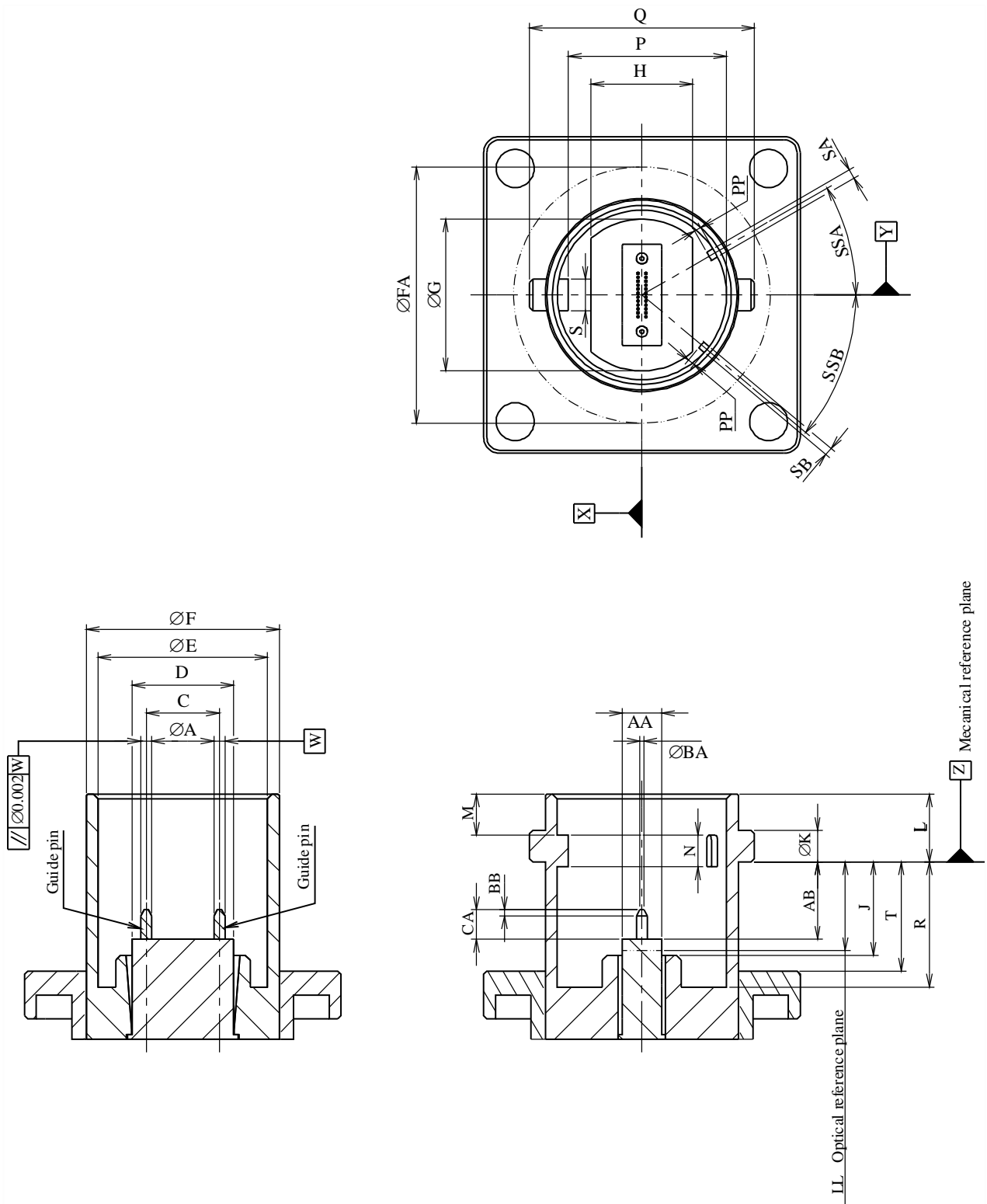

TABLE 2-19

Dimensions of the receptacle connector of equipment

Reference	Dimensions	
	minimum	maximum
A	0.697 mm	0.699 mm
C	4.597 mm	4.603 mm
D	6.3 mm	6.5 mm
E	10.7 mm	10.8 mm
F	12.2 mm	12.4 mm
G	–	9.6 mm
H	–	6.4 mm
J	5.7 mm	–
K	1.8 mm	2.2 mm
L	4.3 mm	4.5 mm
M	1.7 mm	4.0 mm
N	1.0 mm	–
P	9.9 mm	10.1 mm
Q	14.2 mm	14.36 mm
R	9.7 mm	–
S	1.95 mm	2.0 mm
T	6.7 mm	–
AA	2.4 mm	2.5 mm
AB	4.7 mm	5.1 mm
BA	0 mm	0.4 mm
BB	0.2 mm	0.5 mm
CA	1.6 mm	3.3 mm
FA	16.2 mm	–
SA	–	0.6 mm
SB	–	0.5 mm
PP	–	0.45 mm
SSA	29°	31°
SSB	39°	41°

5.1.6 Assignment of 10 G link signals to a receptacle connector

The assignment of 10 G link signals to an output receptacle connector should be as shown in Fig. 2-30, and the assignment of 10 G link signals to an input receptacle connector should be as shown in Fig. 2-31. Each number in Fig. 2-30 and Fig. 2-31 represents the number of a 10 G link signal. Symbol X and Y in Fig. 2-30 and Fig. 2-31 correspond to symbol X and Y respectively in Fig. 2-29.

FIGURE 2-30

Assignment of 10G link signals to an output receptacle connector with equipment

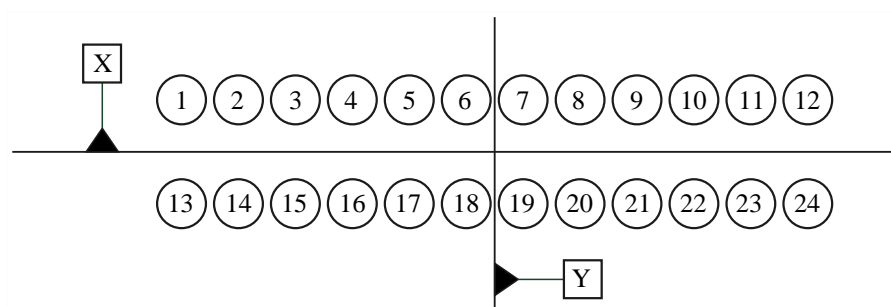

BT.2077-02-30

FIGURE 2-31

Assignment of 10G link signals to an input receptacle connector with equipment

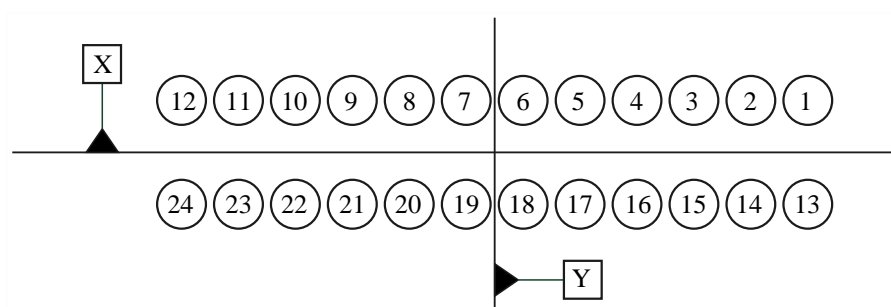

BT.2077-02-31

5.2 Physical layer specification for single mode fibre transmission

5.2.1 Optical transmitter characteristics

The optical transmitter characteristics of each 10 G link should be as shown in Table 2-20. The nominal central frequencies and approximate nominal central wavelengths should be as shown in Table 2-21. In Fig. 2-32, normalized amplitudes of 0 and 1 represent the amplitudes of logic ZERO and ONE respectively. These are defined by the means of the lower and upper halves of the central 0.2 UI of the eye. A UI is the period of one clock cycle of a 10 G link signal. The eye pattern should be measured with respect to the mask of the eye using a receiver with a fourth-order Bessel-Thomson response with a 3 dB frequency of $0.75 \times 10.692 \text{ GHz} = 8 \text{ GHz}$.

TABLE 2-20

Optical transmitter characteristics

Optical wavelength	See Table 2-21
Wavelength accuracy	±100 pm
−20 dB spectral width (max)	1 nm
Signal rate	10.692 GBd ±10 ppm, or 10.692/1.001 GBd ±10 ppm
Average launch power (max) (Note 1)	+4 dBm
Average launch power (min) (Note 1)	−1 dBm
Extinction ratio (min)	8.2 dB
Maximum reflected power	−21 dB
Output optical eye mask (Note 2)	See Fig. 2-32
Jitter	See § 5.2.3
Electrical/optical transfer function	Logic "1" = Higher optical power Logic "0" = Lower optical power

NOTE 1 – Power is the average power measured with an average-reading power meter.

NOTE 2 – One thousand accumulated waveforms are recommended for transmitter optical output eye mask compliance test.

TABLE 2-21

Nominal central frequencies and approximate nominal central wavelengths

10 G link number	Nominal central frequencies	Approximate nominal central wavelengths
1	192.5 THz	1 557.36 nm
2	192.6 THz	1 556.55 nm
3	192.7 THz	1 555.75 nm
4	192.8 THz	1 554.94 nm
5	192.9 THz	1 554.13 nm
6	193.0 THz	1 553.33 nm
7	193.1 THz	1 552.52 nm
8	193.2 THz	1 551.72 nm
9	193.3 THz	1 550.92 nm
10	193.4 THz	1 550.12 nm
11	193.5 THz	1 549.32 nm
12	193.6 THz	1 548.51 nm
13	193.7 THz	1 547.72 nm
14	193.8 THz	1 546.92 nm
15	193.9 THz	1 546.12 nm
16	194.0 THz	1 545.32 nm
17	194.1 THz	1 544.53 nm
18	194.2 THz	1 543.73 nm
19	194.3 THz	1 542.94 nm

TABLE 2-21 (end)

10 G link number	Nominal central frequencies	Approximate nominal central wavelengths
20	194.4 THz	1 542.14 nm
21	194.5 THz	1 541.35 nm
22	194.6 THz	1 540.56 nm
23	194.7 THz	1 539.77 nm
24	194.8 THz	1 538.98 nm

FIGURE 2-32

Transmitter output optical eye mask

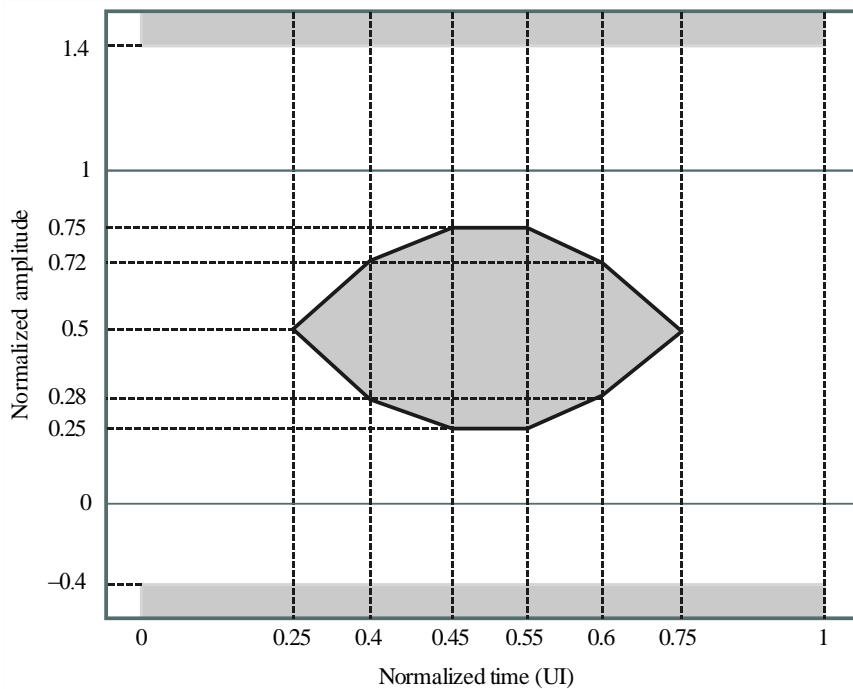

BT.2077-02-32

5.2.2 Optical receiver characteristics

The optical receiver characteristics of each 10G link should be as shown in Table 2-22. Within the receiver input range a BER < 10⁻¹² should be achieved with colour bar test signals or PRBS-31 pattern (when testing system components with BER testers). A BER < 10⁻¹⁴ is recommended. Measurement for 5 minutes is recommended for verifying BER = 10⁻¹² when using BER-based test equipment.

NOTE – The PRBS-31 pattern generator is defined in IEEE 802.3ae-2002.

TABLE 2-22

Optical receiver characteristics

Average receive power (max) (Note 1)	-1 dBm
Average receive power (min) (Note 1)	-15.5 dBm
Detector damage threshold (min)	+4 dBm
Jitter	See § 5.2.3
Optical/electrical transfer function	Higher optical power = Logic "1" Lower optical power = Logic "0"

NOTE 1 – Power is the average power measured with an average-reading power meter.

5.2.3 Jitter specifications

Jitter specifications should be the same as that of § 5.1.3.

5.2.4 Timing difference

Timing difference between 10G link signals should be the same as that of § 5.1.4.

5.2.5 Optical connector

An optical connector should be SC/PC simplex defined by IEC 61754-4.

PART 3

1 Definition of terms

4 320-line image	7 680 × 4 320 pixel image specified for the UHDTV system
2 160-line image	3 840 × 2 160 pixel image specified for the UHDTV system
2 160-line Intermediate sub-image	3 840 × 2 160 pixel image obtained by sub-sampling of a 4 320-line image
1 080-line sub-image	1 920 × 1 080-line image obtained by sub-sampling of 2 160-line image or 2 160-line intermediate sub-image. Each 1 080-line sub-image is transported in N data streams, where N may be 1, 2, 4 or 8 dependent on the image structure and frame frequency
4 320/ Fr	4 320-line image with frame frequency of Fr ($Fr = 120, 120/1.001, 100, 60, 60/1.001, 50, 30, 30/1.001, 25, 24, 24/1.001$)
2 160/ Fr	2 160-line image or intermediate sub-image with frame frequency of Fr ($Fr = 120, 120/1.001, 100, 60, 60/1.001, 50, 30, 30/1.001, 25, 24, 24/1.001$)
1 080/ Fr	1 080-line sub-image with frame frequency of Fr ($Fr = 120, 120/1.001, 100, 60, 60/1.001, 50, 30, 30/1.001, 25, 24, 24/1.001$)
Image structure	The structure of the video samples of the source image (image structure = 4:2:2 10-bit, 4:2:0 10-bit, 4:4:4:4 R'G'B'+A 10-bit, 4:4:4:4 Y'C' _B C' _R +A 10-bit, 4:4:4 R'G'B' 12-bit, 4:4:4 Y'C' _B C' _R 12-bit, 4:2:2:4 Y'C' _B C' _R +A 12-bit)
Data stream	A 10-bit-word multiplexed data stream with a clock rate of 148.5 MHz, or 148.5/1.001 MHz, which consists of an EAV (end of active video) timing reference code, a line number (LN), a CRCC (cyclic redundancy check code) error detection code, ancillary data or blanking data, an SAV (start of active video) timing reference code, and video data. Each 1 080-line sub-image is transported by N data streams, where N may be 1, 2, 4 or 8 dependent on the image structure and frame frequency.
Active line	The video sample data words that constitute one line of video data in a data stream
Active frame	1080 lines that include all active lines
Frame blanking	The lines between an active frame and the next active frame

2 Overview of UHDTV mapping into multi-link 6G-SDI, 12G-SDI and 24G-SDI signals**2.1 Mapping for 4 320-line images**

The mapping of 4 320-line images to single or multiple 6G, 12G or 24G link signals is illustrated in Fig. 3-1.

FIGURE 3-1

Mapping overview for 4 320-line images with 120 Hz, 120/1.001 Hz, 100 Hz, 60 Hz, 60/1.001 Hz, 50 Hz, 30 Hz, 30/1.001 Hz, 24 Hz, or 24/1.001 Hz frame frequency

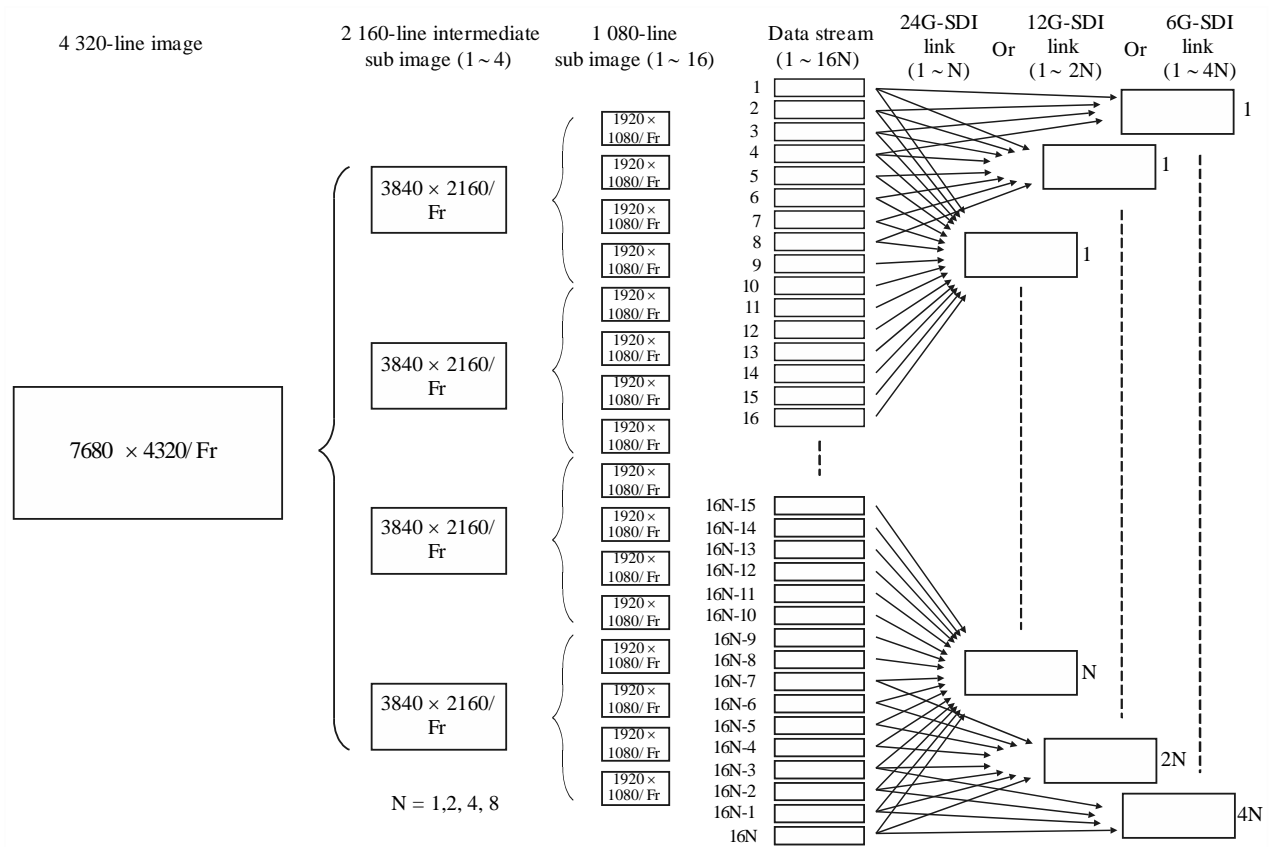

BT.2077-03-01

The 4 320-line source image is divided to produce four 2 160-line intermediate sub-images, each of which is then further divided to produce sixteen 1 080-line sub-images.

Those sixteen 1 080-line sub-images are mapped into 16N data streams, each four of which are combined to one 6G link signal to generate 4N 6G link signals, or each eight of which are combined to one 12G link signal to generate 2N 12G link signals, or each sixteen of which are combined to one 24G link signal to generate N 24G link signals.

Table 3-1 lists the number of data streams required for each 4 320-line source image format, and the number of 6G, 12G or 24G links required to transport them.

TABLE 3-1

4 320-line image formats

4 320-line Source image structure	Number of 1 080-line sub-images	Frame frequency (Hz)	1 080-line Sub-image structure	Number of data streams per 1 080-line sub-image (N)	Number of data streams	Number of 6G links	Number of 12G links	Number of 24G links
4:2:2 Y'C _B C _R 10-bit 4:2:0 Y'C _B C _R 10-bit	16	120, 120/1.001	1	4	64	– ¹	– ¹	4
		100	1	4	64	– ¹	– ¹	4
		60, 60/1.001	1	2	32	– ¹	4	2
		50	1	2	32	– ¹	4	2
		30, 30/1.001	1	1	16	4	2	1
		25	1	1	16	4	2	1
4:4:4 R'G'B' (+A) 10-bit 4:4:4 Y'C _B C _R (+A) 10-bit	16	120, 120/1.001	II	8	128	– ¹	– ¹	8
		100	II	8	128	– ¹	– ¹	8
		60, 60/1.001	II	4	64	– ¹	– ¹	4
		50	II	4	64	– ¹	– ¹	4
		30, 30/1.001	2	2	32	– ¹	4	2
		25	2	2	32	– ¹	4	2
4:4:4 R'G'B' 12-bit 4:4:4 Y'C _B C _R 12-bit	16	120, 120/1.001	III	8	128	– ¹	– ¹	8
		100	III	8	128	– ¹	– ¹	8
		60, 60/1.001	III	4	64	– ¹	8	4
		50	III	4	64	– ¹	8	4
		30, 30/1.001	3	2	32	– ¹	4	2
		25	3	2	32	– ¹	4	2
4:2:2:4 Y'C _B C _R (+A) 12-bit	16	120, 120/1.001	IV	8	128	– ¹	– ¹	8
		100	IV	8	128	– ¹	– ¹	8
		60, 60/1.001	IV	4	64	– ¹	– ¹	4
		50	IV	4	64	– ¹	– ¹	4
		30, 30/1.001	4	2	32	– ¹	4	2
		25	4	2	32	– ¹	4	2
4:2:2:4 Y'C _B C _R (+A) 12-bit	16	24, 24/1.001	4	2	32	– ¹	4	2

NOTE 1 – Each image frame frequency and image structure has a video payload. For each video payload there is flexibility in the choice of interface. For example a 4:2:2 10-bit image at 25 Hz has a video payload which can be transported by a quad-link 6G interface, a dual-link 12G interface or a single link 24G interface. Where there is no entry in the columns indicating the number of Links required, the interface is not appropriate for that particular image structure, and an alternative should be selected which does support the chosen image format. For example a 4:2:2 10-bit image at 60 Hz can be transported by an quad-link 12G interface or a dual-link 24G interface, but there is no appropriate 6G interface available.

2.2 Mapping for 2 160-line images with 120 Hz, 120/1.001 Hz, 100 Hz, 60 Hz, 60/1.001 Hz, 50 Hz, 30 Hz, 30/1.001 Hz, 24 Hz, or 24/1.001 Hz frame frequency

The mapping of 2 160-line images to single or multiple 6G, 12G, or 24G link signals is illustrated in Fig. 3-2.

FIGURE 3-2

Mapping overview for 2 160-line images

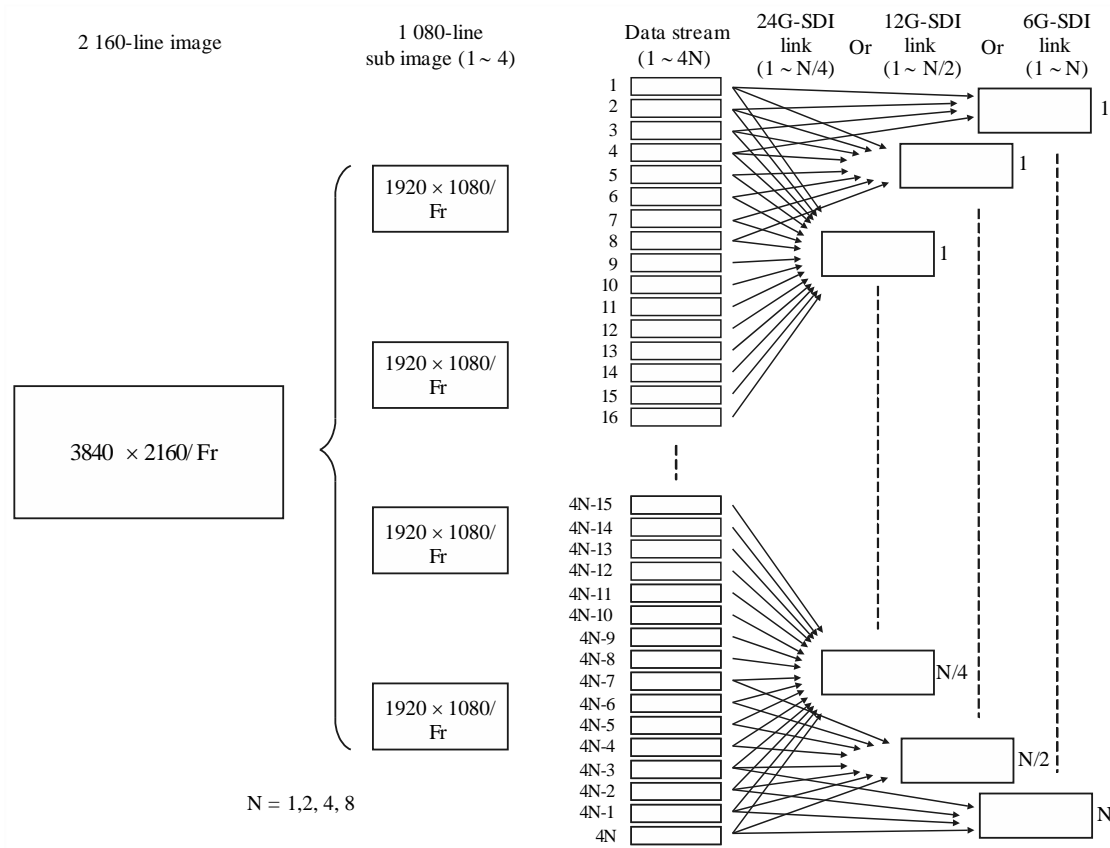

BT.2077-03-02

For 2 160-line images the source image is divided to produce four 1 080-line sub-images. Those four 1 080-line sub-images are mapped into 4N data streams, each four of which are combined to one 6G link signal to generate N 6G link signals, or each eight of which are combined to one 12G link signal to generate N/2 12G link signals, or each sixteen of which are combined to one 24G link signal to generate N/4 24G link signals.

TABLE 3-2

2 160-line image formats

2 160-line Source image structure	Number of 1 080-line sub-images	Frame frequency (Hz)	1 080-line Sub-image structure	Number of data streams per 1 080-line sub-image (N)	Number of data streams	Number of 6G links	Number of 12G links	Number of 24G links
4:2:2 Y'C _B C _R ' 10-bit or 4:2:0 Y'C _B C _R ' 10-bit	4	120, 120/1.001	1	4	16	4	2	1
		100	1	4	16	4	2	1
		60, 60/1.001	1	2	8	2	1	1 ²
		50	1	2	8	2	1	1 ²
		30, 30/1.001	1	1	4	1	- ²	1 ²
		25	1	1	4	1	- ²	1 ²
24, 24/1.001	1	1	4	1	- ²	1 ²		
4:4:4 R'G'B' (+A) 10-bit or 4:4:4 Y'C _B C _R '(+A) 10-bit	4	120, 120/1.001	II	8	32	- ¹	4	2
		100 ⁴	II	8	32	- ¹	4	2
		60, 60/1.001	II	4	16	4	2	1
		50	II	4	16	4	2	1
		30, 30/1.001	2	2	8	2	1	1 ²
		25	2	2	8	2	1	1 ²
24, 24/1.001	2	2	8	2	1	1 ²		
4:4:4 R'G'B' 12-bit or 4:4:4 Y'C _B C _R ' 12-bit	4	120, 120/1.001	III	8	32	- ¹	4	2
		100	III	8	32	- ¹	4	2
		60, 60/1.001	III	4	32	4	2	1
		50	III	4	32	4	2	1
		30, 30/1.001	3	2	32	2	1	1 ²
		25	3	2	32	2	1	1 ²
24, 24/1.001	3	2	32	2	1	1 ²		
4:2:2:4 Y'C _B C _R '(+A) 12-bit	4	120, 120/1.001	IV	8	32	- ¹	4	2
		100	IV	8	32	- ¹	4	2
		60, 60/1.001	IV	4	32	4	2	1
		50	IV	4	32	4	2	1
		30, 30/1.001	4	2	32	2	1	1 ²
		25	4	2	32	2	1	1 ²
24, 24/1.001	4	2	32	2	1	1 ²		

NOTE 1 – Each image frame frequency and image structure has a video payload. For each video payload there is flexibility in the choice of interface. For example a 4:4:4 12-bit image at 60 Hz has a video payload which can be transported by a quad-link 6G interface, a dual-link 12G interface or a single link 24G interface. Where there is no entry in the columns indicating the number of Links required, the interface is not appropriate for that particular image structure, and an alternative should be selected which does support the chosen image format. For example a 4:4:4 12-bit image at 120 Hz can be transported by an quad-link 12G interface or a dual-link 24G interface, but there is no appropriate 6G interface available.

NOTE 2 – In some cases the maximum capacity of the interface exceeds the requirement of the image. For example a 4:2:2 10-bit image at 50 Hz can be transported by a single link 12G interface, but does not require the data rate of a 24G interface. In this case the 12G signal would be transported over the 24G infrastructure at 12G. Similarly a 6G signal would be transported over the 12G or 24G infrastructure at 6G.

NOTE – Interface selection (Informative)

Where there is a choice of interfaces for a particular image format the choice can be made based on the infrastructure available. Choice of infrastructure can be made taking into consideration economic and operational factors, including other image formats to be transported using the same infrastructure and the maximum cable length as indicated in Table 1 of this Recommendation.

A 6G infrastructure will support all 2 160-line image formats with the exception of 100 Hz to 120 Hz inclusive 4:4:4 10-bit or 12-bit image formats by using single-, dual- or quad-link interfaces. Support for 4 320-line image formats is limited to 4:2:2 or 4:2:0 10-bit formats at up to 30 Hz frame frequency.

A 12G infrastructure will support all 2 160-line image formats and 4 320-line 4:2:2 or 4:2:0 10-bit image formats at up to 60 Hz frame frequency by using single-, dual- or quad-link interfaces.

A 24G infrastructure will support all 2 160-line and 4 320-line formats by using single-, dual-, quad- or octal-link interfaces.

The choice of infrastructure does not exclude interoperability with equipment or exchange using a different choice. Simple interoperability between different choices of infrastructure may be enabled by the use of gearbox devices, as described in Attachment 2 to Part 3.

3 Image division into 1 080-line sub-images**3.1 Division of 4 320-line image into 4 × 2 160-line intermediate sub-images**

The 4 320-line source image division into four 2 160-line intermediate sub-images uses the 2-sample interleave division process.

Figure 3-3 shows 2-sample interleave division of a 4 320-line image into four 2 160-line images. Even lines of the 4 320-line source image should be divided into 2 160-line intermediate sub-images 1 and 2 as per two consecutive horizontal samples, and odd lines should be divided into 2 160-line intermediate sub-images 3 and 4 as per two consecutive horizontal samples.

FIGURE 3-3

2-sample interleave division of 4 320-line image into 2 160-line images

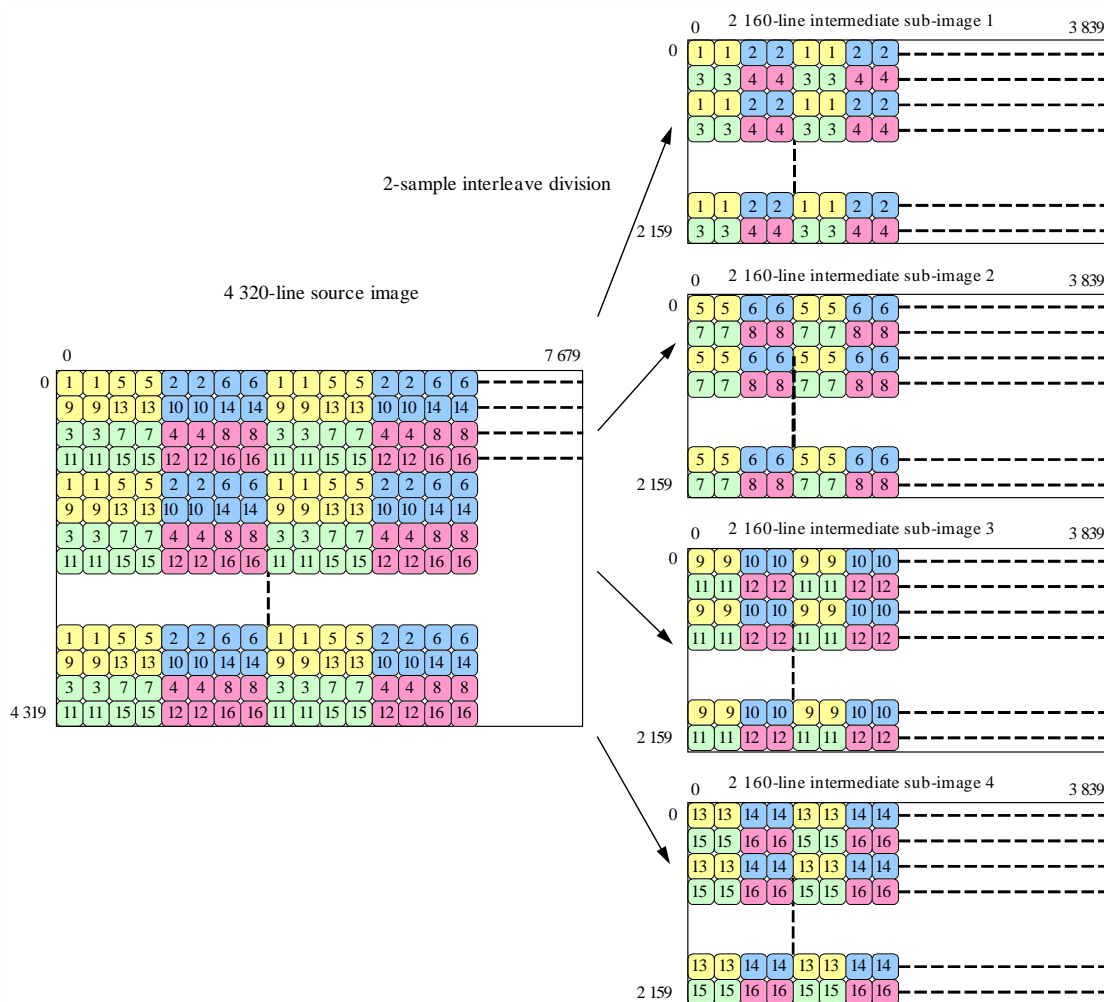

BT.2077-03-03

The 2 160-line intermediate sub-images have the same image structure as the 4 320-line source image with the exception of 4:2:0 source images. In this case:

- The 0 components of the 4:2:0 (even-numbered samples on odd-numbered lines of unassigned $C'_B C'_R$) system image data should be assigned 200_h ($512_{(10)}$) in case of a 10-bit system and 800_h ($2048_{(10)}$) in case of a 12-bit system. The resulting intermediate sub-images 1 and 2 will thus have a 4:2:2 image structure with the all of the C'_B and C'_R components from the source image, and intermediate sub-images 3 and 4 will have a 4:2:2 image structure with the C'_B and C'_R components assigned 200_h in the case of a 10-bit system or 800_h in the case of a 12-bit system.

See Attachment 1 to Part 3 “Image Division by Image Structure” for details.

3.2 Division of 2 160-line image or intermediate sub-image into 4 × 1 080-line sub-images

The 2 160-line image is divided into four 1 080-line sub-images using 2-sample interleave division. Figure 3-4 shows 2-sample interleave division of a 2 160-line image into four 1 080-line images. Even lines of the 2 160-line image should be divided into 1 080-line sub-images 1 and 2 as per two consecutive horizontal samples, and odd lines should be divided into 1 080-line sub-images 3 and 4 as per two consecutive horizontal samples.

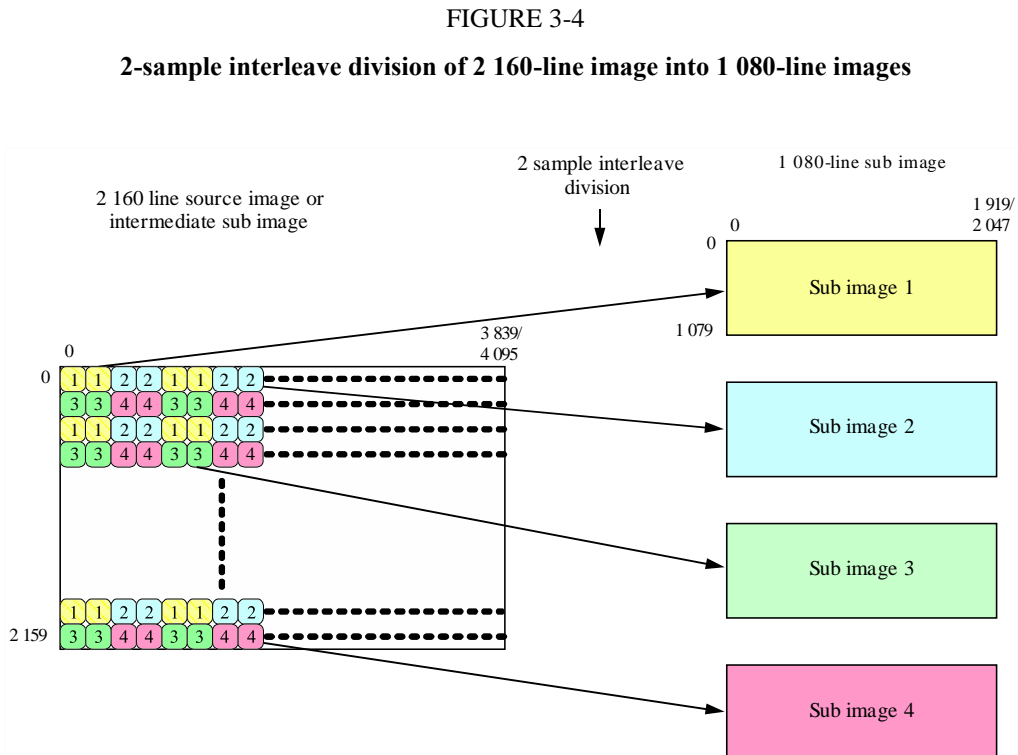

For 4 320-line source images, 2 160-line intermediate sub-image 1 should be divided to 1 080-line sub-images 1 to 4 inclusive.

Similarly 2 160-line intermediate sub-image 2 should be divided to 1 080-line sub-images 5 to 8 inclusive.

Similarly 2 160-line intermediate sub-image 3 should be divided to 1 080-line sub-images 9 to 12 inclusive.

Similarly 2 160-line intermediate sub-image 4 should be divided to 1 080-line sub-images 13 to 16 inclusive.

The 1 080-line sub-images have the same image structure as the 4 320-line source image or the 2 160-line source image, with the exception of 4:2:0 source images. In this case:

- For 2 160-line intermediate sub-images originating from a 4:2:0 4 320-line source image, the C'_B and C'_R components of 2 160-line intermediate sub-images 3 and 4 are assigned 200_h ($512_{(10)}$) in case of a 10-bit system and 800_h ($2048_{(10)}$) in case of a 12-bit system. The resulting 1080-line sub-images 1 to 8 inclusive will thus have a 4:2:2 image structure with the all of the C'_B and C'_R components from the source image, and 1 080-line

sub-images 9 to 16 inclusive will have a 4:2:2 image structure with the C'_B and C'_R components assigned 200_h in the case of a 10-bit system or 800_h in the case of a 12-bit system.

- For 2 160-line source images, the 0 components of the 4:2:0 (even-numbered samples on odd-numbered lines of unassigned $C'_B C'_R$) system image data should be assigned 200_h ($512_{(10)}$) in case of a 10-bit system and 800_h ($2\ 048_{(10)}$) in case of a 12-bit system. The resulting 1 080-line sub-images 1 and 2 will thus have a 4:2:2 image structure with the all of the C'_B and C'_R components from the source image, and 1 080-line sub-images 3 and 4 will have a 4:2:2 image structure with the C'_B and C'_R components assigned 200_h in the case of a 10-bit system or 800_h in the case of a 12-bit system.

See Attachment 1 to Part 3 “Image Division by Image Structure” for informative details.

4 Data stream

The frame structure of a data stream is shown in Fig. 3-5 and the data stream word numbering within each line is shown in Table 3-4. A data stream comprises a 1 080-line active frame and a 45-line frame blanking interval.

The 1 080 lines from the sub-image are assigned to lines from line 42 to line 1 121 of the data stream. The frame blanking is assigned to the interval from line 1 to line 41 and from line 1 122 to line 1 125. The structure of the frame blanking has the same line structure as shown in Table 3-4, with the active line region allocated to ancillary data or blanking data.

FIGURE 3-5

Frame structure of data stream

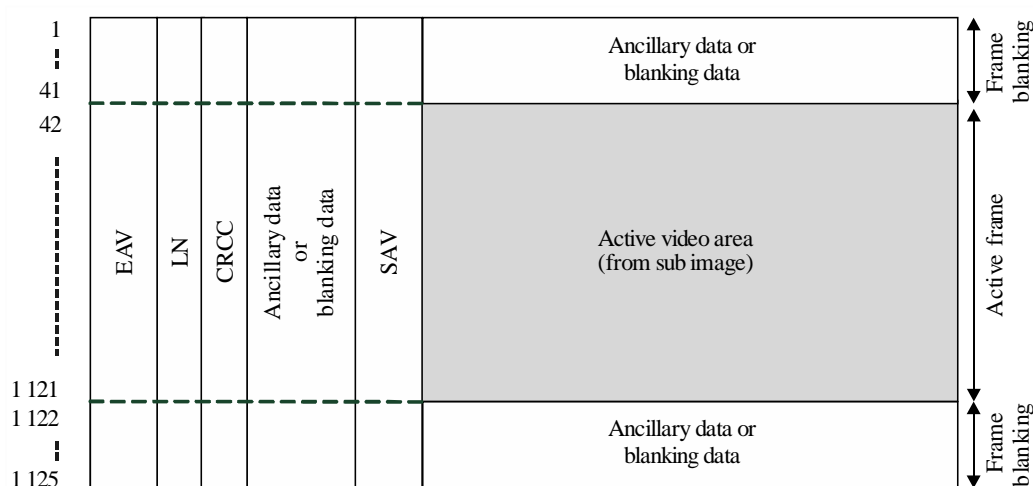

TABLE 3-3

Line numbers of data stream

Item	Line number
Frame blanking	1-41, 1 122-1 125
Active frame	42-1 121

TABLE 3-4

Word numbers of data stream lines

Item	Symbol		Word number						
			120 or 120/1.001 Hz frame frequency	100 Hz frame frequency	60 or 60/1.001 Hz frame frequency	50 Hz frame frequency	30 or 30/1.001 Hz frame frequency	25 Hz frame frequency	24 or 24/1.001 Hz frame frequency
Active line (video data)	D		0-959		0-1 919		0-3 839		
Timing reference code (EAV)	EAV		960-963		1 920-1 923		3 840-3 843 ^{*1} 3 840-3 847 ^{*2}		
Line number data	LN	LN0	964		1 924		3 844 ^{*1} 3 848-3 849 ^{*2}		
		LN1	965		1 925		3 845 ^{*1} 3 850-3 851 ^{*2}		
Cyclic redundancy check codes	CRCC	CRCC0	966		1 926		3 846 ^{*1} 3 852-3 853 ^{*2}		
		CRCC1	967		1 927		3 847 ^{*1} 3 854-3 855 ^{*2}		
Ancillary data or Blanking data	ANC		968-1 095	968-1 315	1 928- 2 195	1 928- 2 635	3 848- 4 395 ^{*1} 3 856- 4 391 ^{*2}	3 848- 5 275 ^{*1} 3 856- 5 271 ^{*2}	3 848- 5 495 ^{*1} 3 856- 5 491 ^{*2}
Timing reference code (SAV)	SAV		1 096-1 099	1 316- 1 319	2 196- 2 199	2 636- 2 639	4 396- 4 399 ^{*1} 4 392- 4 399 ^{*2}	5 276- 5 279 ^{*1} 5 272- 5 279 ^{*2}	5 496- 5 499 ^{*1} 5 492- 5 499 ^{*2}

NOTE 1 – For all image structures except Image Structure 1.

NOTE 2 – For Image Structure 1.

4.1 100, 120/1.001 and 120 Hz images

Each sub-image is mapped into N data streams. N may be equal to four or eight according to the image structure.

Each data stream has an active video container of size $960 \times 1\,080$ words at the source frame frequency.

FIGURE 3-6

Line structure of each data stream for 120 Hz, 120/1.001 Hz or 100 Hz frame frequencies

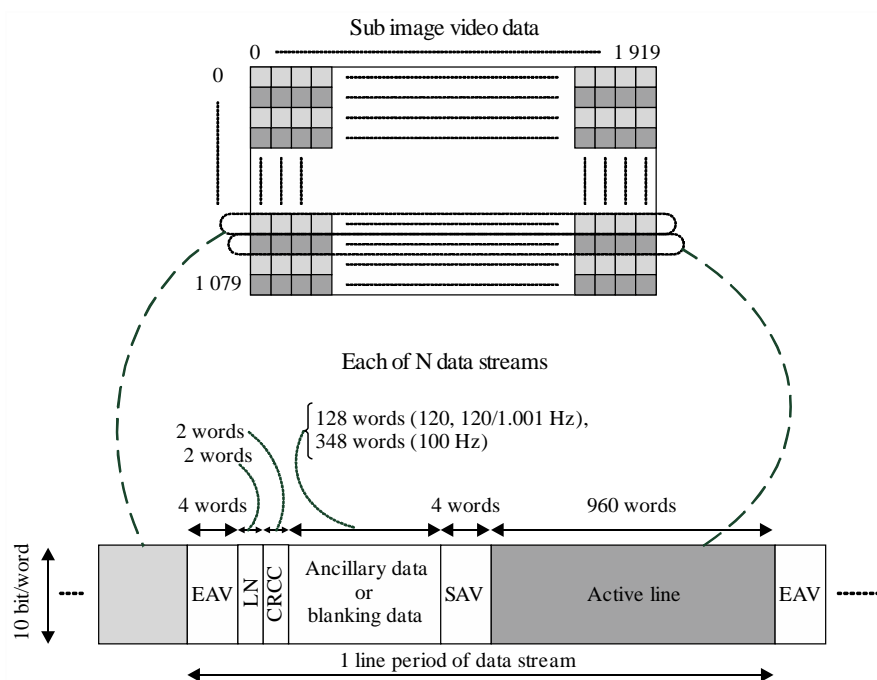

BT.2077-03-06

4.1.1 Mapping of sub-images to data streams

Image Structure 1 – Y'C'B C'R 4:2:2 or 4:2:0 10-bit

For this Image Structure $N = 4$

Sub-image 1

Data stream one carries the odd Y' samples: Y'1, Y'3, Y'5, Y'7 ...

Data Stream two carries the C'R samples: C'R0, C'R2, C'R4...

Data stream three carries the even Y' samples: Y'0, Y'2, Y'4, Y'6 ...

Data Stream four carries the C'B samples: C'B0, C'B2, C'B4...

Sub-image 2 is similarly mapped into data streams five to eight inclusive

Sub-image 3 is similarly mapped into data streams nine to twelve inclusive

Sub-image 4 is similarly mapped into data streams thirteen to sixteen inclusive

For 4 320-line images there are 16 sub-images. In this case:

Sub-image 5 mapping

Data stream seventeen carries the odd Y' samples: Y'1, Y'3, Y'5, Y'7 ...

Data Stream eighteen carries the C'R samples: C'R0, C'R2, C'R4...

Data stream nineteen carries the even Y' samples: Y'0, Y'2, Y'4, Y'6 ...

Data Stream twenty carries the C'B samples: C'B0, C'B2, C'B4...

Sub-image 6 is similarly mapped into data streams twenty one to twenty four inclusive

Sub-image 7 is similarly mapped into data streams twenty five to twenty eight inclusive

Sub-image 8 is similarly mapped into data streams twenty nine to thirty two inclusive

Sub-image 9 is similarly mapped into data streams thirty three to thirty six inclusive
 Sub-image 10 is similarly mapped into data streams thirty seven to forty inclusive
 Sub-image 11 is similarly mapped into data streams forty one to forty four inclusive
 Sub-image 12 is similarly mapped into data streams forty five to forty eight inclusive
 Sub-image 13 is similarly mapped into data streams forty nine to fifty two inclusive
 Sub-image 14 is similarly mapped into data streams fifty three to fifty six inclusive
 Sub-image 15 is similarly mapped into data streams fifty seven to sixty inclusive
 Sub-image 16 is similarly mapped into data streams sixty one to sixty four inclusive

Image Structure II – RGB 4:4:4 or 4:4:4:4 10-bit

For this Image Structure $N = 8$

Sub-image 1

Data stream one carries odd G' samples:	$G'1, G'3, G'5...$
Data stream two carries even R' samples:	$R'0, R'2, R'4...$
Data stream three carries even G' samples:	$G'0, G'2, G'4...$
Data stream four carries even B' samples:	$B'0, B'2, B'4...$
Data stream five carries odd A values:	$A1, A3, A5...$
Data stream six carries odd R' samples:	$R'1, R'3, R'5...$
Data stream seven carries even A values:	$A0, A2, A4...$
Data stream eight carries odd B' samples:	$B'1, B'3, B'5...$

Sub-image 2 is similarly mapped into data streams nine to sixteen inclusive

Sub-image 3 is similarly mapped into data streams seventeen to twenty four inclusive

Sub-image 4 is similarly mapped into data streams twenty five to thirty two inclusive

For 4 320-line images there are 16 sub images. In this case:

Sub image 5 mapping

Data stream thirty three carries odd G' samples:	$G'1, G'3, G'5...$
Data stream thirty four carries even R' samples:	$R'0, R'2, R'4...$
Data stream thirty five carries even G' samples:	$G'0, G'2, G'4...$
Data stream thirty six carries even B' samples:	$B'0, B'2, B'4...$
Data stream thirty seven carries odd A values:	$A1, A3, A5...$
Data stream thirty eight carries odd R' samples:	$R'1, R'3, R'5...$
Data stream thirty nine carries even A values:	$A0, A2, A4...$
Data stream forty carries odd B' samples:	$B'1, B'3, B'5...$

Sub image 6 is similarly mapped into data streams forty one to forty eight four inclusive

Sub image 7 is similarly mapped into data streams forty nine to fifty six inclusive

Sub image 8 is similarly mapped into data streams fifty seven to sixty four inclusive

Sub image 9 is similarly mapped into data streams sixty five to seventy two inclusive

Sub image 10 is similarly mapped into data streams seventy three to eighty inclusive

Sub image 11 is similarly mapped into data streams eighty one to eighty eight inclusive

Sub image 12 is similarly mapped into data streams eighty nine to ninety six inclusive

Sub image 13 is similarly mapped into data streams ninety seven to one hundred four inclusive

Sub image 14 is similarly mapped into data streams one hundred five to one hundred twelve inclusive

Sub image 15 is similarly mapped into data streams one hundred thirteen to one hundred twenty inclusive

Sub image 16 is similarly mapped into data streams one hundred twenty one to one hundred twenty eight inclusive

Image Structure III – R'G'B' 4:4:4 12-bit

For this Image Structure $N = 8$

Sub-image 1

Data stream one carries the 10 MSBs of odd G' samples: G'5:2-11...	G'1:2-11, G'3:2-11,
Data stream two carries the 10 MSBs of even R' samples: R'4:2-11...	R'0:2-11, R'2:2-11,
Data stream three carries the 10 MSBs of even G' samples: G'4:2-11...	G'0:2-11, G'2:2-11,
Data stream four carries the 10 MSBs of even B' samples: B'4:2-11...	B'0:2-11, B'2:2-11,
Data stream five carries the 2 LSBs of odd R'G'B' samples: R'G'B'3:0-1, R'G'B'5:0-1...	R'G'B'1:0-1,
Data stream six carries the 10 MSBs of odd R' samples: R'5:2-11...	R'1:2-11, R'3:2-11,
Data stream seven carries the 2 LSBs of even R'G'B' samples: R'G'B'2:0-1, R'G'B'4:0-1...	R'G'B'0:0-1,
Data stream eight carries the 10 MSBs of odd B' samples: B'5:2-11...	B'1:2-11, B' 3:2-11,

Sub-image 2 is similarly mapped into data streams nine to sixteen inclusive

Sub-image 3 is similarly mapped into data streams seventeen to twenty four inclusive

Sub-image 4 is similarly mapped into data streams twenty five to thirty two inclusive

For 4 320-line images there are 16 sub images. In this case:

Sub image 5 mapping

Data stream thirty three carries the 10 MSBs of odd G' samples: G'5:2-11....	G'1:2-11, G'3:2-11,
Data stream thirty four carries the 10 MSBs of even R' samples: R'4:2-11...	R'0:2-11, R'2:2-11,
Data stream thirty five carries the 10 MSBs of even G' samples: G'4:2-11...	G'0:2-11, G'2:2-11,
Data stream thirty six carries the 10 MSBs of even B' samples: B'4:2-11...	B'0:2-11, B'2:2-11,
Data stream thirty seven carries the 2 LSBs of odd R'G'B' samples: R'G'B'3:0-1, R'G'B'5:0-1	R'G'B'1:0-1,

Data stream thirty eight carries the 10 MSBs of odd R' samples: R'1:2-11, R'3:2-11, R'5:2-11 ...

Data stream thirty nine carries the 2 LSBs of even R'G'B' samples: R'G'B'0:0-1, R'G'B'2:0-1, R'G'B'4:0-1

Data stream forty carries the 10 MSBs of odd B' samples: B'1:2-11, B'3:2-11, B'5:2-11 ...

Sub image 6 is similarly mapped into data streams forty one to forty eight four inclusive

Sub image 7 is similarly mapped into data streams forty nine to fifty six inclusive

Sub image 8 is similarly mapped into data streams fifty seven to sixty four inclusive

Sub image 9 is similarly mapped into data streams sixty five to seventy two inclusive

Sub image 10 is similarly mapped into data streams seventy three to eighty inclusive

Sub image 11 is similarly mapped into data streams eighty one to eighty eight inclusive

Sub image 12 is similarly mapped into data streams eighty nine to ninety six inclusive

Sub image 13 is similarly mapped into data streams ninety seven to one hundred four inclusive

Sub image 14 is similarly mapped into data streams one hundred five to one hundred twelve inclusive

Sub image 15 is similarly mapped into data streams one hundred thirteen to one hundred twenty inclusive

Sub image 16 is similarly mapped into data streams one hundred twenty one to one hundred twenty eight inclusive

Image Structure IV – Y'C_BC_R+A 4:2:2:4 12-bit

For this Image Structure $N = 8$

Sub-image 1

Data stream one carries the 10 MSBs of odd Y' samples: Y'1:2-11, Y'3:2-11, Y'5:2-11...

Data stream two carries the 10 MSBs of even C_R' samples: C_R'0:2-11, C_R'2:2-11, C_R'4:2-11...

Data stream three carries the 10 MSBs of even Y' samples: Y'0:2-11, Y'2:2-11, Y'4:2-11...

Data stream four carries the 10 MSBs of even C_B' samples: C_B'0:2-11, C_B'2:2-11, C_B'4:2-11...

Data stream five carries the 2 LSBs of odd Y' samples: Y'1:0-1, Y'3:0-1, Y'5:0-1...

Data stream six carries the odd A samples: A1, A3, A5...

Data stream seven carries the 2 LSBs of even Y'C_BC_R' samples: Y'C_BC_R'0:0-1, Y'C_BC_R'2:0-1, Y'C_BC_R'4:0-1...

Data stream eight carries the even A values: A0, A2, A4...

Sub-image 2 is similarly mapped into data streams nine to sixteen inclusive

Sub-image 3 is similarly mapped into data streams seventeen to twenty four inclusive

Sub-image 4 is similarly mapped into data streams twenty five to thirty two inclusive

For 4 320-line images there are 16 sub images. In this case:

Sub image 5 mapping

Data stream thirty three carries the 10 MSBs of odd Y' samples:	$Y'1:2-11, Y'3:2-11, Y'5:2-11\dots$
Data stream thirty four carries the 10 MSBs of even C'_R samples:	$C'_R0:2-11, C'_R2:2-11, C'_R4:2-11\dots$
Data stream thirty five carries the 10 MSBs of even Y' samples:	$Y'0:2-11, Y'2:2-11, Y'4:2-11\dots$
Data stream thirty six carries the 10 MSBs of even C'_B samples:	$C'_B0:2-11, C'_B2:2-11, C'_B4:2-11\dots$
Data stream thirty seven carries the 2 LSBs of odd Y' samples:	$Y'1:0-1, Y'3:0-1, Y'5:0-1\dots$
Data stream thirty eight carries the odd A samples:	$A1, A3, A5\dots$
Data stream thirty nine carries the 2 LSBs of even $Y'C'_B C'_R$ samples:	$Y'C'_B C'_R0:0-1, Y'C'_B C'_R2:0-1, Y'C'_B C'_R4:0-1\dots$
Data stream forty carries the even A values:	$A0, A2, A4\dots$

Sub image 6 is similarly mapped into data streams forty one to forty eight four inclusive

Sub image 7 is similarly mapped into data streams forty nine to fifty six inclusive

Sub image 8 is similarly mapped into data streams fifty seven to sixty four inclusive

Sub image 9 is similarly mapped into data streams sixty five to seventy two inclusive

Sub image 10 is similarly mapped into data streams seventy three to eighty inclusive

Sub image 11 is similarly mapped into data streams eighty one to eighty eight inclusive

Sub image 12 is similarly mapped into data streams eighty nine to ninety six inclusive

Sub image 13 is similarly mapped into data streams ninety seven to one hundred four inclusive

Sub image 14 is similarly mapped into data streams one hundred five to one hundred twelve inclusive

Sub image 15 is similarly mapped into data streams one hundred thirteen to one hundred twenty inclusive

Sub image 16 is similarly mapped into data streams one hundred twenty one to one hundred twenty eight inclusive

4.2 50, 60/1.001 and 60 Hz images

Each sub-image is mapped into N data streams. N may be equal to two or four according to the image structure.

Each data stream has an active video container of size $1\,920 \times 1\,080$ words at the source frame frequency.

FIGURE 3-7

Line structure of each Data Stream for 60 Hz, 60/1.001 Hz and 50 Hz frame frequencies

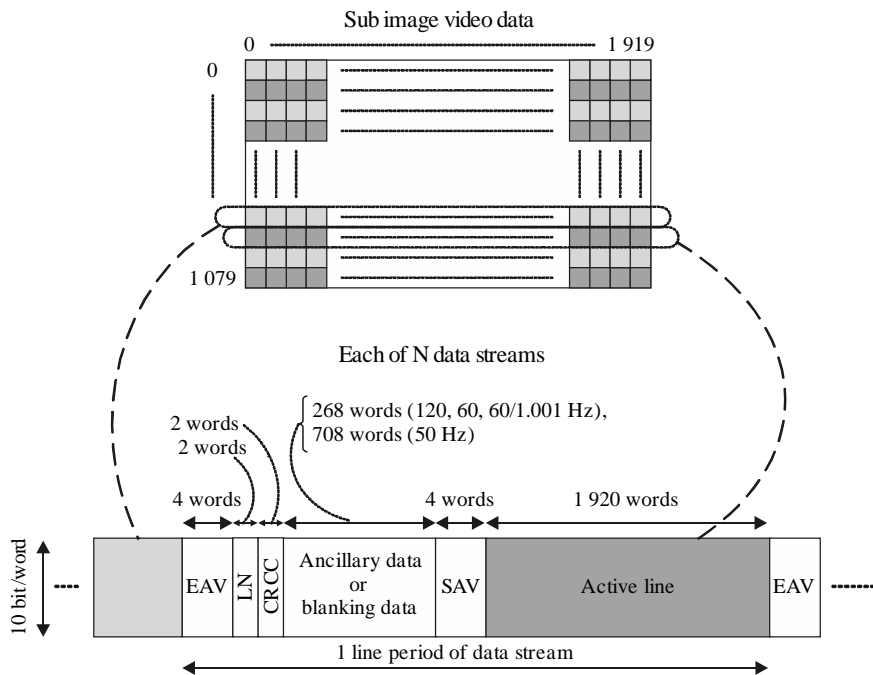

BT.2077-03-07

4.2.1 Mapping of sub-images to data streams

Image Structure 1 – Y'C_BC_R 4:2:2 or 4:2:0 10-bit

For this Image Structure $N = 2$

Sub-image 1

Data stream one carries the Y' samples: Y'0, Y'1, Y'2, Y'3...

Data stream two carries the C'_B and C'_R samples: C'_B0, C'_R0, C'_B2, C'_R2...

Sub-image 2 is similarly mapped into data streams three and four

Sub-image 3 is similarly mapped into data streams five and six

Sub-image 4 is similarly mapped into data streams seven and eight

For 4 320-line images there are 16 sub-images. In this case:

Sub-image 5 mapping:

Data stream nine carries the Y' samples: Y'0, Y'1, Y'2, Y'3...

Data stream ten carries the C'_B and C'_R samples: C'_B0, C'_R0, C'_B2, C'_R2...

Sub-image 6 is similarly mapped into data streams eleven and twelve

Sub-image 7 is similarly mapped into data streams thirteen and fourteen

Sub-image 8 is similarly mapped into data streams fifteen and sixteen

Sub-image 9 is similarly mapped into data streams seventeen and eighteen

Sub-image 10 is similarly mapped into data streams nineteen and twenty

Sub-image 11 is similarly mapped into data streams twenty one and twenty two

Sub-image 12 is similarly mapped into data streams twenty three and twenty four

Sub-image 13 is similarly mapped into data streams twenty five and twenty six

Sub-image 14 is similarly mapped into data streams twenty seven and twenty eight

Sub-image 15 is similarly mapped into data streams twenty nine and thirty

Sub-image 16 is similarly mapped into data streams thirty one and thirty two

Image Structure II – R'G'B' 4:4:4 or 4:4:4:4 10-bit

For this Image Structure $N = 4$

Sub-image 1

Data stream one carries the G' samples: G'0, G'1, G'2, G'3...

Data stream two carries even B' and R' samples: B'0, R'0, B'2, R'2...

Data stream three carries the A values: A0, A1, A2, A3...

Data stream four carries odd B' and R' samples: B'1, R'1, B'3, R'3...

Sub-image 2 is similarly mapped into data streams five to eight inclusive

Sub-image 3 is similarly mapped into data streams nine to twelve inclusive

Sub-image 4 is similarly mapped into data streams thirteen to sixteen inclusive

For 4 320-line images there are 16 sub-images. In this case:

Sub-image 5 mapping:

Data stream seventeen carries the G' samples: G'0, G'1, G'2, G'3...

Data stream eighteen carries even B' and R' samples: B'0, R'0, B'2, R'2...

Data stream nineteen carries the A values: A0, A1, A2, A3...

Data stream twenty carries odd B' and R' samples: B'1, R'1, B'3, R'3...

Sub-image 6 is similarly mapped into data streams twenty one to twenty four inclusive

Sub-image 7 is similarly mapped into data streams twenty five to twenty eight inclusive

Sub-image 8 is similarly mapped into data streams twenty nine to thirty two inclusive

Sub-image 9 is similarly mapped into data streams thirty three to thirty six inclusive

Sub-image 10 is similarly mapped into data streams thirty seven to forty inclusive

Sub-image 11 is similarly mapped into data streams forty one to forty four inclusive

Sub-image 12 is similarly mapped into data streams forty five to forty eight inclusive

Sub-image 13 is similarly mapped into data streams forty nine to fifty two inclusive

Sub-image 14 is similarly mapped into data streams fifty three to fifty six inclusive

Sub-image 15 is similarly mapped into data streams fifty seven to sixty inclusive

Sub-image 16 is similarly mapped into data streams sixty one to sixty four inclusive

For the 4:4:4 (Y'C_BC_R) and the 4:4:4:4 (Y'C_BC_R+A)/10-bit images, the image data are conveyed as above except that:

The G' samples are replaced with Y' samples.

The B' samples are replaced with C_B' samples.

The R' samples are replaced with C_R' samples.

If Alpha samples are not present they are replaced with the value 040_h.

Image Structure III – R'G'B' 4:4:4 12-bit

For this Image Structure $N = 4$

Sub-image 1

Data stream one carries the 10 MSBs of the G' samples: G'0:2-11, G'1:2-11, G'2:2-11, G'3:2-11...

Data stream two carries the 10 MSBs of even B' and R' samples: B'0:2-11, R'0:2-11, B'2:2-11, R'2:2-11...

Data stream three carries the 2 LSBs of the R'G'B' samples: R'G'B'0:0-1, R'G'B'1:0-1, R'G'B'2:0-1...

Data stream four carries the 10 MSBs of odd B' and R' samples: B'1:2-11, R'1:2-11, B'3:2-11, R'3:2-11...

Sub-image 2 is similarly mapped into data streams five to eight inclusive

Sub-image 3 is similarly mapped into data streams nine to twelve inclusive

Sub-image 4 is similarly mapped into data streams thirteen to sixteen inclusive

For 4 320-line images there are 16 sub-images. In this case:

Sub-image 5 mapping

Data stream seventeen carries the 10 MSBs of the G' samples: G'0:2-11, G'1:2-11, G'2:2-11, G'3:2-11...

Data stream eighteen carries the 10 MSBs of even B' and R' samples: B'0:2-11, R'0:2-11, B'2:2-11, R'2:2-11...

Data stream nineteen carries the 2 LSBs of the R'G'B' samples: R'G'B'0:0-1, R'G'B'1:0-1, R'G'B'2:0-1...

Data stream twenty carries the 10 MSBs of odd B' and R' samples: B'1:2-11, R'1:2-11, B'3:2-11, R'3:2-11...

Sub-image 6 is similarly mapped into data streams twenty one to twenty four inclusive

Sub-image 7 is similarly mapped into data streams twenty five to twenty eight inclusive

Sub-image 8 is similarly mapped into data streams twenty nine to thirty two inclusive

Sub-image 9 is similarly mapped into data streams thirty three to thirty six inclusive

Sub-image 10 is similarly mapped into data streams thirty seven to forty inclusive

Sub-image 11 is similarly mapped into data streams forty one to forty four inclusive

Sub-image 12 is similarly mapped into data streams forty five to forty eight inclusive

Sub-image 13 is similarly mapped into data streams forty nine to fifty two inclusive

Sub-image 14 is similarly mapped into data streams fifty three to fifty six inclusive

Sub-image 15 is similarly mapped into data streams fifty seven to sixty inclusive

Sub-image 16 is similarly mapped into data streams sixty one to sixty four inclusive

Image Structure IV – Y'C'B'C'R+A 4:2:2:4 12-bit

For this Image Structure $N = 4$

Sub-image 1

The 2 LSBs of odd C'_B and C'_R samples should be “00” for this Image Structure.

Data stream one carries the 10 MSBs of the Y' samples: $Y'0:2-11,$
 $Y'1:2-11, Y'2:2-11, Y'3:2-11...$

Data stream two carries the 10 MSBs of even C'_B and C'_R samples: $C'_B0:2-11,$
 $C'_R0:2-11, C'_B2:2-11, C'_R2:2-11$

Data stream three carries the 2 LSBs of $Y'C'_B C'_R$ samples: $Y'C'_B C'_R0:0-1,$
 $Y'C'_B C'_R1:0-1, Y'C'_B C'_R2:0-1, Y'C'_B C'_R3:0-1...$

Data stream four carries the even A values: $A0, A1, A2, A3...$

Sub-image 2 is similarly mapped into data streams five to eight inclusive

Sub-image 3 is similarly mapped into data streams nine to twelve inclusive

Sub-image 4 is similarly mapped into data streams thirteen to sixteen inclusive

For 4 320-line images there are 16 sub-images. In this case:

Sub-image 5 mapping:

Data stream seventeen carries the 10 MSBs of the Y' samples: $Y'0:2-11,$
 $Y'1:2-11, Y'2:2-11, Y'3:2-11...$

Data stream eighteen carries the 10 MSBs of even C'_B and C'_R samples: $C'_B0:2-$
 $11, C'_R0:2-11, C'_B2:2-11, C'_R2:2-11$

Data stream nineteen carries the 2 LSBs of $Y'C'_B C'_R$ samples: $Y'C'_B C'_R0:0-1,$
 $Y'C'_B C'_R1:0-1, Y'C'_B C'_R2:0-1, Y'C'_B C'_R3:0-1...$

Data stream twenty carries the even A values: $A0, A1, A2, A3...$

Sub-image 6 is similarly mapped into data streams twenty one to twenty four inclusive

Sub-image 7 is similarly mapped into data streams twenty five to twenty eight inclusive

Sub-image 8 is similarly mapped into data streams twenty nine to thirty two inclusive

Sub-image 9 is similarly mapped into data streams thirty three to thirty six inclusive

Sub-image 10 is similarly mapped into data streams thirty seven to forty inclusive

Sub-image 11 is similarly mapped into data streams forty one to forty four inclusive

Sub-image 12 is similarly mapped into data streams forty five to forty eight inclusive

Sub-image 13 is similarly mapped into data streams forty nine to fifty two inclusive

Sub-image 14 is similarly mapped into data streams fifty three to fifty six inclusive

Sub-image 15 is similarly mapped into data streams fifty seven to sixty inclusive

Sub-image 16 is similarly mapped into data streams sixty one to sixty four inclusive

4.3 24/1.001, 24, 25, 30/1.001, and 30 Hz images

Each sub-image is mapped into N data streams. N may be equal to one or two according to the image structure.

Each data stream has an active video container of size $3\ 840 \times 1\ 080$ words at the source frame frequency.

FIGURE 3-8

Line structure of each Data Stream for 30 Hz, 30/1.001 Hz, 25 Hz, 24 Hz and 24/1.001 Hz frame frequencies – Image Structure 1

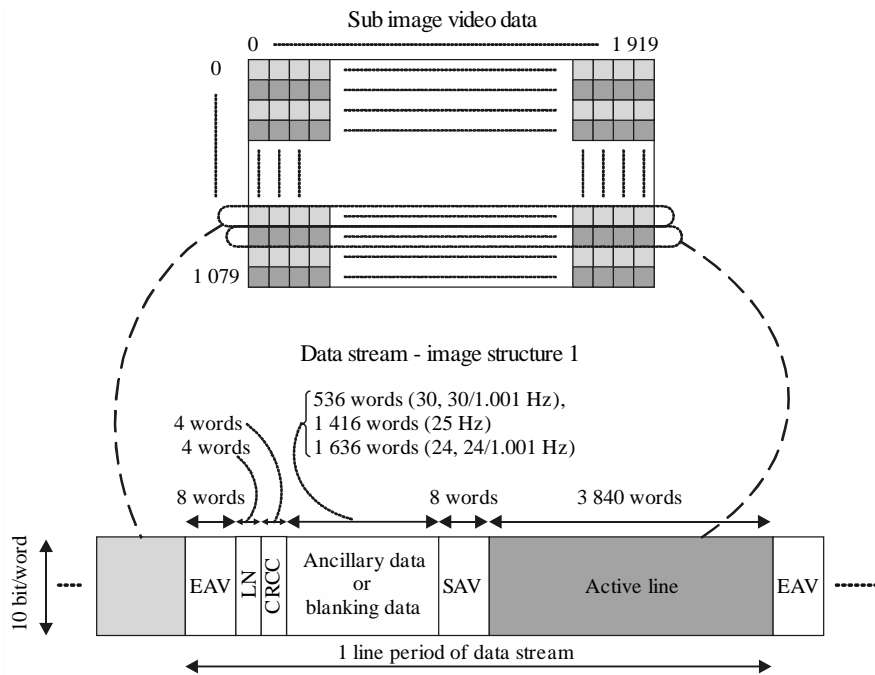

BT.2077-03-08

For Image Structure 1 images (4:2:2 or 4:2:0 10-bit) each sub-image is mapped into a single multiplexed parallel data stream according to Recommendation ITU-R BT.1120-8 Fig. 3.

This multiplexed data stream is a multiplex of a C channel and a Y channel, each containing EAV, SAV, LN and CRC data and 1920 words of video data.

Each line of the resulting data stream thus has double length EAV, SAV, LN and CRC data components, and 3840 words of video data. See Fig. 3-8 above.

FIGURE 3-9

Line structure of each Data Stream for 30 Hz, 30/1.001 Hz, 25 Hz, 24 Hz and 24/1.001 Hz frame frequencies – Image Structures 2, 3 and 4

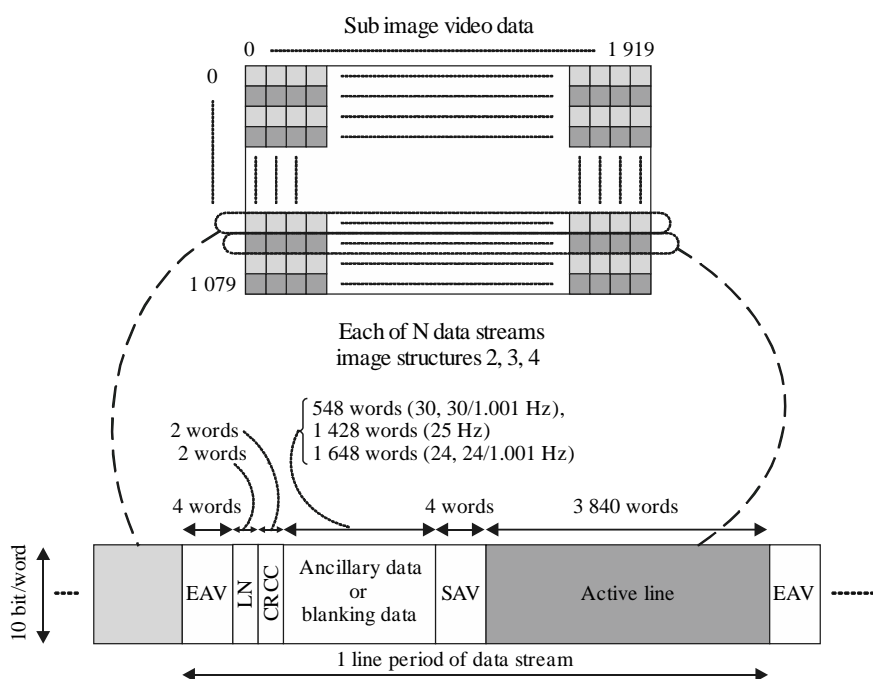

BT.2077-03-09

For Image Structures 2, 3 and 4, each data stream contains a single instance of EAV, SAV, LN and CRC per line, together with the video data as defined in § 4.3.1 below. As each active video line part of the data stream consists of a multiplex of two components, each line contains 3 840 words of video. See Fig. 3-9 above.

4.3.1 Mapping of sub-images to data streams

Image Structure 1 – Y'C'B'C'R 4:2:2 or 4:2:0 10-bit

For this Image Structure $N = 1$

Sub-image 1

Data stream one carries all samples: $C'_B0, Y'0, C'_R0, Y'1, C'_B2, Y'2, C'_R2, Y'3...$

Sub-image 2 is similarly mapped into data stream two

Sub-image 3 is similarly mapped into data stream three

Sub-image 4 is similarly mapped into data streams four

For 4 320-line images there are 16 sub-images. In this case:

Sub-image 5 mapping:

Data stream five carries all samples: $C'_B0, Y'0, C'_R0, Y'1, C'_B2, Y'2, C'_R2, Y'3...$

Sub-image 6 is similarly mapped into data stream six

Sub-image 7 is similarly mapped into data stream seven

Sub-image 8 is similarly mapped into data stream eight

Sub-image 9 is similarly mapped into data stream nine

Sub-image 10 is similarly mapped into data stream ten

Sub-image 11 is similarly mapped into data stream eleven
 Sub-image 12 is similarly mapped into data stream twelve
 Sub-image 13 is similarly mapped into data stream thirteen
 Sub-image 14 is similarly mapped into data stream fourteen
 Sub-image 15 is similarly mapped into data stream fifteen
 Sub-image 16 is similarly mapped into data stream sixteen

Image Structure 2 – R'G'B' 4:4:4 or 4:4:4:4 10-bit

For this Image Structure $N = 2$

Sub-image 1

Data stream one carries the G' and R' samples: $G'0, R'0, G'1, R'1, G'2, R'2\dots$

Data stream two carries the A values and B' samples: $A0, B'0, A1, B'1, A2, B'2\dots$

Sub-image 2 is similarly mapped into data streams three and four
 Sub-image 3 is similarly mapped into data streams five and six
 Sub-image 4 is similarly mapped into data streams seven and eight

For 4 320-line images there are 16 sub-images. In this case:

Sub-image 5 mapping:

Data stream nine carries the G' and R' samples: $G'0, R'0, G'1, R'1, G'2, R'2\dots$

Data stream ten carries the A values and B' samples: $A0, B'0, A1, B'1, A2, B'2\dots$

Sub-image 6 is similarly mapped into data streams eleven and twelve
 Sub-image 7 is similarly mapped into data streams thirteen and fourteen
 Sub-image 8 is similarly mapped into data streams fifteen and sixteen
 Sub-image 9 is similarly mapped into data streams seventeen and eighteen
 Sub-image 10 is similarly mapped into data streams nineteen and twenty
 Sub-image 11 is similarly mapped into data streams twenty one and twenty two
 Sub-image 12 is similarly mapped into data streams twenty three and twenty four
 Sub-image 13 is similarly mapped into data streams twenty five and twenty six
 Sub-image 14 is similarly mapped into data streams twenty seven and twenty eight
 Sub-image 15 is similarly mapped into data streams twenty nine and thirty
 Sub-image 16 is similarly mapped into data streams thirty one and thirty two

For the 4:4:4 ($Y'C'_B C'_R$) and the 4:4:4:4 ($Y'C'_B C'_R + A$)/10-bit images, the image data are conveyed as above except that:

The G' samples are replaced with Y' samples.

The B' samples are replaced with C'_B samples.

The R' samples are replaced with C'_R samples.

If Alpha samples are not present they are replaced with the value 040_h.

Image Structure 3 – R'G'B' 4:4:4 12-bit

For this Image Structure $N = 2$

Bit b9 in every word is the complement of b8. The lists and table below describe Bits b8 – b0

Sub-image 1

Data stream one carries six bits of the R'G'B' samples: R'G'B'0:11-9,
R'G'B'0:5-3, R'G'B'1:11-9, R'G'B'1:5-3...

Data stream two carries the remaining six bits of the R'G'B' samples: R'G'B'0:8-6,
R'G'B'0:2-0, R'G'B'1:8-6, R'G'B'1:2-0...

TABLE 3-5

R'G'B' (i): x-y Bit structure mapping into data words of the virtual interface

Bit number										
Data stream	B9	B8	B7	B6	B5	B4	B3	B2	B1	B0
Data stream one first word of sample (i)	— B8	R' (i):11-9			G' (i):11-9			B' (i):11-9		
Data stream one second word of sample (i)	— B8	R' (i):5-3			G' (i):5-3			B' (i):5-3		
Data stream two first word of sample (i)	— B8	R' (i):8-6			G' (i):8-6			B' (i):8-6		
Data stream two second word of sample (i)	— B8	R' (i):2-0			G' (i):2-0			B' (i):2-0		

Sub-image 2 is similarly mapped into data streams three and four

Sub-image 3 is similarly mapped into data streams five and six

Sub-image 4 is similarly mapped into data streams seven and eight

For 4 320-line images there are 16 sub-images. In this case:

Sub-image 5 mapping:

Data stream nine carries six bits of the R'G'B' samples: R'G'B'0:11-9,
R'G'B'0:5-3, R'G'B'1:11-9, R'G'B'1:5-3...

Data stream ten carries the remaining six bits of the R'G'B' samples: R'G'B'0:8-6,
R'G'B'0:2-0, R'G'B'1:8-6, R'G'B'1:2-0...

Sub-image 6 is similarly mapped into data streams eleven and twelve

Sub-image 7 is similarly mapped into data streams thirteen and fourteen

Sub-image 8 is similarly mapped into data streams fifteen and sixteen

Sub-image 9 is similarly mapped into data streams seventeen and eighteen

Sub-image 10 is similarly mapped into data streams nineteen and twenty

Sub-image 11 is similarly mapped into data streams twenty one and twenty two

Sub-image 12 is similarly mapped into data streams twenty three and twenty four

Sub-image 13 is similarly mapped into data streams twenty five and twenty six

Sub-image 14 is similarly mapped into data streams twenty seven and twenty eight

Sub-image 15 is similarly mapped into data streams twenty nine and thirty

Sub-image 16 is similarly mapped into data streams thirty one and thirty two

Image Structure 4 – Y'C_BC_R+A 4:2:2:4 12-bit

For this Image Structure $N = 2$

Bit b9 in every word is the complement of b8. The lists and table below describe Bits b8 – b0

Sub-image 1

Data stream one:

Bits b8 – b6: A0:11-9, A0:5-3, A1:11-9, A1:5-3...

Bits b5 – b0: Y'0:11-6, Y'0:5-0, Y'1:11-6, Y'1:5-0...

Data stream two:

Bits b8 – b6: A0:8-6, A0:2-0, A1:8-6, A1:2-0...

Bits b5 – b0: C_B 0:11-6, C_B 0:5-0, C_R 0:11-6, C_R 0:5-0...

TABLE 3-6

Y'(2i+r):x-y and A(2i+r):x-y Bit structure mapping into data words of the virtual interface

Data stream	Bit number									
	9	8	7	6	5	4	3	2	1	0
Data stream one first word of sample (2i)	— B:8	A (2i):11-9			Y' (2i):11-6					
Data stream one second word of sample (2i)	— B:8	A (2i):5-3			Y' (2i):5-0					
Data stream one first word of sample (2i + 1)	— B:8	A (2i + 1):11-9			Y' (2i+1):11-6					
Data stream one second word of sample (2i + 1)	— B:8	A (2i + 1):5-3			Y' (2i+1):5-0					
Data stream two first word of sample (2i)	— B:8	A (2i):8-6			C _B (2i):11-6					
Data stream two second word of sample (2i)	— B:8	A (2i):2-0			C _B (2i):5-0					
Data stream two first word of sample (2i + 1)	— B:8	A (2i + 1):8-6			C _R (2i):11-6					
Data stream two second word of sample (2i + 1)	— B:8	A (2i + 1):2-0			C _R (2i):5-0					

Sub-image 2 is similarly mapped into data streams three and four

Sub-image 3 is similarly mapped into data streams five and six

Sub-image 4 is similarly mapped into data streams seven and eight

For 4 320-line images there are 16 sub-images. In this case:

Sub-image 5 mapping:

Data stream nine:

Bits b8 – b6: A0:11-9, A0:5-3, A1:11-9, A1:5-3...

Bits b5 – b0: Y'0:11-6, Y'0:5-0, Y'1:11-6, Y'1:5-0...

Data stream ten:

Bits b8 – b6: A0:8-6, A0:2-0, A1:8-6, A1:2-0...

Bits b5 – b0: C'_B 0:11-6, C'_B 0:5-0, C'_R 0:11-6, C'_R 0:5-0...

Sub-image 6 is similarly mapped into data streams eleven and twelve

Sub-image 7 is similarly mapped into data streams thirteen and fourteen

Sub-image 8 is similarly mapped into data streams fifteen and sixteen

Sub-image 9 is similarly mapped into data streams seventeen and eighteen

Sub-image 10 is similarly mapped into data streams nineteen and twenty

Sub-image 11 is similarly mapped into data streams twenty one and twenty two

Sub-image 12 is similarly mapped into data streams twenty three and twenty four

Sub-image 13 is similarly mapped into data streams twenty five and twenty six

Sub-image 14 is similarly mapped into data streams twenty seven and twenty eight

Sub-image 15 is similarly mapped into data streams twenty nine and thirty

Sub-image 16 is similarly mapped into data streams thirty one and thirty two

4.5 Timing reference codes (SAV and EAV)

The two timing reference codes are the SAV, which is placed immediately before the video data (active line), and the EAV, which is placed immediately after the video data. The bit assignments for the SAV and EAV are as defined in Recommendation ITU-R BT.1120-8 Table 5. The protection bit assignments are as defined in Recommendation ITU-R BT.1120-8 Table 6.

In Recommendation ITU-R BT.1120-8 Tables 5 and 6, F is an identification bit for progressive/interlaced (first/second field).

The images in Part 3 of this Recommendation are all progressive, so the value of F is fixed at 0. The V is an identifier bit for the frame blanking and the active video data. The value of V is 1 in the frame blanking from line 1 to line 41 and from line 1122 to line 1125; the value is 0 in the active video data from line 42 to line 1121. The H is an identifier bit that has a value of 0 for SAV and 1 for EAV. The values P0 through P3 are parity bits, which are used for one bit error correction and two bits error detection on the receiving side. The assignment of those bits is defined as shown in Recommendation ITU-R BT.1120-8 Table 6.

4.6 Line number data

The line numbering of the data stream uses the line numbers as defined in Recommendation ITU-R BT.1120-8 section 4.1.3. The line numbers refer to the sub-image rather than to the 4 320-line or 2 160-line source image.

4.7 Error detection code data

The data stream error detection code data is represented by the 18 bits from CRCC0 to CRCC17 and is as defined in Recommendation ITU-R BT.1120-8, § 4.1.4.

4.8 Ancillary data

Recommendation ITU-R BT.1364 describes the format and protocol for the use of ancillary data packets.

The format of ancillary data packets for use with this interface should conform to Recommendation ITU-R BT.1364.

Protocol for the use of ancillary data space in this interface should conform to Recommendation ITU-R BT.1364 with the following exceptions:

For all source images other than Image Structure 1 images with 30 Hz, 30/1.001 Hz, 25 Hz, 24 Hz and 24/1.001 Hz frame frequencies, the recommendations relating to the luminance channel should refer to odd-numbered data streams and the recommendations relating to the colour-difference channel should refer to even-numbered data streams

For all source images other than Image Structure 1 images with 30 Hz, 30/1.001 Hz, 25 Hz, 24 Hz and 24/1.001 Hz frame frequencies, unless otherwise stated, the ancillary data should be preferentially mapped into data stream one first and any remaining data should then be mapped onto data stream three; then into data stream five and so on up to the limit of the number of data streams in the interface.

For Image Structure 1 images with 30 Hz, 30/1.001 Hz, 25 Hz, 24 Hz and 24/1.001 Hz frame frequencies, unless otherwise stated, the ancillary data should be preferentially mapped into the luminance channel of data stream one first, and any remaining data should then be mapped into the luminance channel of data stream two; then data stream three and so on up to the limit of the number of data streams in the interface.

Data space requirements and locations for each data service are defined by their respective application documents. In some cases it is required by specific applications that ancillary data be mapped into all of the data streams in the interface (e.g. payload ID.)

4.9 Audio

Each sub-image has the format of a 1 080-line HDTV image and should have audio embedded according to Recommendation ITU-R BT.1365.

Recommendation ITU-R BT.1365 describes the generation and insertion of audio ancillary data packets, including audio control packets and audio data packets, for up to 4 audio groups, groups 1 through 4. This allows for up to 16 channels of audio sampled at 48 kHz, or up to 8 channels of audio sampled at 96 kHz.

A further 4 extended audio groups, groups 5, 6, 7 and 8, allowing for up to 32 channels at 48 kHz or up to 16 channels at 96 kHz, can be inserted using the techniques described in Recommendation ITU-R BT.1365 with different DID values for the audio data packets and audio control packets.

The DID values for extended audio data packets should be 1A7_h for audio group 5, 2A6_h for audio group 6, 2A5_h for audio group 7 and 1A4_h for audio group 8.

The DID values for extended audio control packets should be 2A3_h for audio group 5, 1A2_h for audio group 6, 1A1_h for audio group 7 and 2A0_h for audio group 8.

The audio clock phase data as defined in Recommendation ITU-R BT.1365 should be calculated using a clock frequency of 74.25 (/1.001) MHz for signals with frame frequencies of 30 Hz, 30/1.001 Hz, 25 Hz, 24 Hz and 24/1.001 Hz.

The audio clock phase data as defined in Recommendation ITU-R BT.1365 should be calculated using a clock frequency of 148.5 (/1.001) MHz for all other signals.

4.9.1 Transport of the maximum number of audio channels

Audio should be embedded preferentially into data stream pair one/two. Any additional audio that cannot fit into data stream pair one/two should be embedded into data stream pair three/four. Similarly, further additional audio should be embedded into data stream pair five/six, and so on up to the limit of the number of data streams in the interface.

For Image Structure 1 images with 30 Hz, 30/1.001 Hz, 25 Hz, 24 Hz and 24/1.001 Hz frame frequencies, audio should be embedded preferentially into data stream one. Any additional audio that cannot fit into data stream one should be embedded into data stream two. Similarly, further additional audio should be embedded into data stream three, and so on up to the limit of the number of data streams in the interface.

4.9.2 Audio copy between links

Alternatively, audio signals may be copied between data stream pairs, in order to allow that each physical 6G-SDI or 12G-SDI link carries a copy of the embedded audio. In this case:

A block of data stream pairs should be allocated for original audio.

The block may consist of:

Data stream pair one/two OR

Data stream pairs one/two and three/four OR

Data streams one/two, three/four, five/six and seven/eight.

Within this block, audio should be embedded preferentially into data stream pair one/two. Any additional audio that cannot fit into data stream pair one/two should be embedded into data stream pair three/four if present. Similarly, further additional audio should be embedded into data stream pair five/six, and finally into data stream pair seven/eight.

Audio in the block should be copied into equal sized blocks up to the limit of the number of data streams in the interface.

For example:

- If data stream pairs one/two and three/four are allocated for original audio, and the interface contains a total of sixteen data streams, then
 - Data stream pair five/six carries a copy of the audio from data stream pair one/two, and data stream pair seven/eight carries a copy of the audio from data stream pair three/four.
 - Data stream pair nine/ten carries a copy of the audio from data stream pair one/two, and data stream pair eleven/twelve carries a copy of the audio from data stream pair three/four.
 - Data stream pair thirteen/fourteen carries a copy of the audio from data stream pair one/two, and data stream pair fifteen/sixteen carries a copy of the audio from data stream pair three/four.

The audio copy status of each data stream should be signalled in the payload ID. See § 4.10.

NOTE – Audio copy reduces the number of channels that can be transported by the interface.

4.10 Payload ID

Every data stream should contain a payload ID packet. This should be a type 2 ancillary data packet with DID value of 41_h, SDID value of 01_h and four UDW words. The recommended location is immediately after the error detection code data in line 10.

The UDW bit assignment of payload ID packet is shown in Table 3-7. The payload ID packet must be multiplexed once per frame of each data stream.

TABLE 3-7
Payload identifier definitions

Bit number	Byte 1	Byte 2	Byte 3	Byte 4
b7	See Table 3-8	Progressive transport (1)	Aspect ratio 16:9 (1) or Unknown (0)	6G, 12G or 24G link assignment Link1 (0 _h) – Link 8 (7 _h)
b6		Progressive picture (1)	Horizontal sampling 1920 (0) or 2048 ⁵ (1)	
b5		Transfer characteristics SDR-TV (0 _h) HLG (1 _h) PQ (2 _h) Unspecified (3 _h)	Colorimetry Recommendation ITU-R BT.709 ⁶ (0 _h) Reserved (1 _h) Recommendation ITU-R BT.2020 (2 _h) Reserved (3 _h)	Luminance and colour difference signal NCL Y'C _B C _R ' (0) CL SDR Y'C _B C _R ' or HDR IC _T C _P (1)
b4				
b3		Picture rate See Table 3-9	Sampling structure identification See Table 3-10	Reserved (0)
b2				Audio copy status: Audio in this data stream carries additional channels (0) Audio in this data stream is copied (1)
b1				Bit depth 10-bit full range (0 _h) 10-bit narrow range (1 _h) 12-bit narrow range (2 _h) 12-bit full range (3 _h)
b0				

TABLE 3-8
Byte 1 assignment

Image format	Transport interface									
	Single 6G	Dual 6G	Quad 6G	Single 12G	Dual 12G	Quad 12G	Single 24G	Dual 24G	Quad 24G	Octal 24G
4 320-line			C4 _h		D0 _h	D2 _h	DF _h	E1 _h	E3 _h	F1 _h
2 160-line	C0 _h	C2 _h	C5 _h	CE _h	D1 _h	D3 _h	E0 _h	E2 _h	–	–

⁵ This bit should be set to “0” for all formats in Part 3 of this Recommendation.

⁶ Not permitted in this Recommendation.

TABLE 3-9

Picture rate

Value	Picture rate	Value	Picture rate	Value	Picture rate	Value	Picture rate
0h	Not defined	1 _h	96/1.001 ⁷	2 _h	24/1.001	3 _h	24
4h	48/1.001 ⁷	5 _h	25	6 _h	30/1.001	7 _h	30
8h	48 ⁷	9 _h	50	A _h	60/1.001	B _h	60
Ch	96 ⁷	D _h	100	E _h	120/1.001	F _h	120

TABLE 3-10

Sampling structure

Value	Sampling	Value	Sampling	Value	Sampling	Value	Sampling
0 _h	4:2:2 (Y'C _B C _R)	1 _h	4:4:4 (Y'C _B C _R)	2 _h	4:4:4 (R'G'B')	3 _h	4:2:0 (Y'C _B C _R)
4 _h	4:2:2:4 (Y'C _B C _R +A)	5 _h	4:4:4:4 (Y'C _B C _R +A)	6 _h	4:4:4:4 (R'G'B'+A)	7 _h	Reserved
8 _h	4:2:2:4 (Y'C _B C _R +D)	9 _h	4:4:4:4 (Y'C _B C _R +D)	A _h	4:4:4:4 (R'G'B'+D)	B _h	Reserved
C _h	Reserved	D _h	Reserved	E _h	Reserved	F _h	Reserved

4.11 Blanking data

The blanking data words occurring during blanking intervals that are not used for the timing reference codes (SAV and EAV), line number data, error detection codes or ancillary data should be set as listed below.

- (1) Data stream samples for colour components Y', R', G', B', 10-bit or 10 MSBs of 12-bit: 040_h
- (2) Data stream samples for colour components C_B, C_R, 10-bit or 10 MSBs of 12-bit: 200_h
- (3) Data stream samples for colour components Y', R', G', B', C_B, C_R 2 LSBs of 12-bit: 200_h
- (4) Data stream values for component A: 040_h
- (5) Data stream samples for R'G'B' 12-bit: 11-9 combined values: 200_h
- (6) Data stream samples for R'G'B' 12-bit: 8-6 combined values: 124_h
- (7) Data stream samples for R'G'B' 12-bit: 5-3 combined values: 200_h
- (8) Data stream samples for R'G'B' 12-bit: 2-0 combined values: 200_h
- (9) Data stream samples for Y'C_BC_R 12-bit: 11-9 combined values: 104_h
- (10) Data stream samples for Y'C_BC_R 12-bit: 8-6 combined values: 220_h
- (11) Data stream samples for Y'C_BC_R 12-bit: 5-3 combined values: 200_h
- (12) Data stream samples for Y'C_BC_R 12-bit: 2-0 combined values: 200_h

⁷ Not permitted in this Recommendation.

5 Generation of 6G link signals

5.1 6G-SDI 10-bit Multiplex

See Tables 3-1 and 3-2 for data stream requirements for each source image format.

Prior to serialization:

For signals where the virtual interface requires four or more data streams:

Data streams one through four should be multiplexed word-by-word into a 6G-SDI 10-bit interface.

The 10-bit interface should consist of a word multiplex of data streams one through four, in the order data stream four, data stream two, data stream three, data stream one ... etc.

For signals where the virtual interface requires eight or more data streams:

Data streams five through eight should be multiplexed word-by-word into a 6G-SDI 10-bit interface.

The 10-bit interface should consist of a word multiplex of data streams five through eight, in the order data stream eight, data stream six, data stream seven, data stream five ... etc.

For signals where the virtual interface requires twelve or more data streams:

Data streams nine through twelve should be multiplexed word-by-word into a 6G-SDI 10-bit interface.

The 10-bit interface should consist of a word multiplex of data streams nine through twelve, in the order data stream twelve, data stream ten, data stream eleven, data stream nine ... etc.

For signals where the virtual interface requires sixteen data streams:

Data streams thirteen through sixteen should be multiplexed word-by-word into a 6G-SDI 10-bit interface.

The 10-bit interface should consist of a word multiplex of data streams thirteen through sixteen, in the order data stream sixteen, data stream fourteen, data stream fifteen, data stream thirteen ... etc.

The 10-bit parallel interfaces so produced should have an interface frequency of 594 MHz or 594/1.001 MHz.

5.1.1 Type 1 and Type 2 10-bit Parallel Interfaces

As shown in Table 3-4 and Fig. 3-8, data streams for 30 Hz, 30/1.001 Hz, 25 Hz, 24 Hz and 24/1.001 Hz frame frequencies images with Image Structure 1 (4:2:2 or 4:2:0 10-bit) have a line structure with double length EAV, SAV, LN and CRC data components. These data streams, when multiplexed, result in a Type 2 10-bit parallel interface. Figure 3-11 shows the Type 2 10-bit parallel interface.

All other images use a Type 1 10-bit parallel interface. Figure 3-10 shows the Type 1 10-bit parallel interface.

FIGURE 3-10
6G-SDI 10-bit Multiplex – Type 1

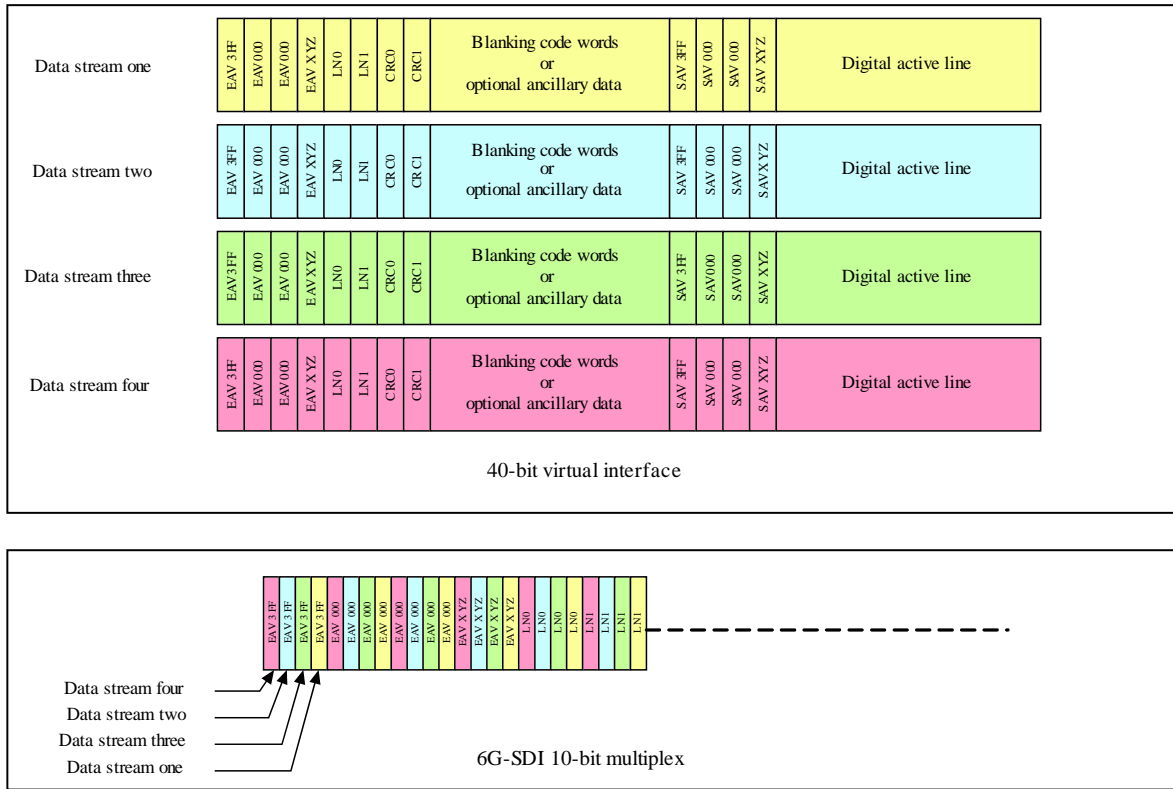
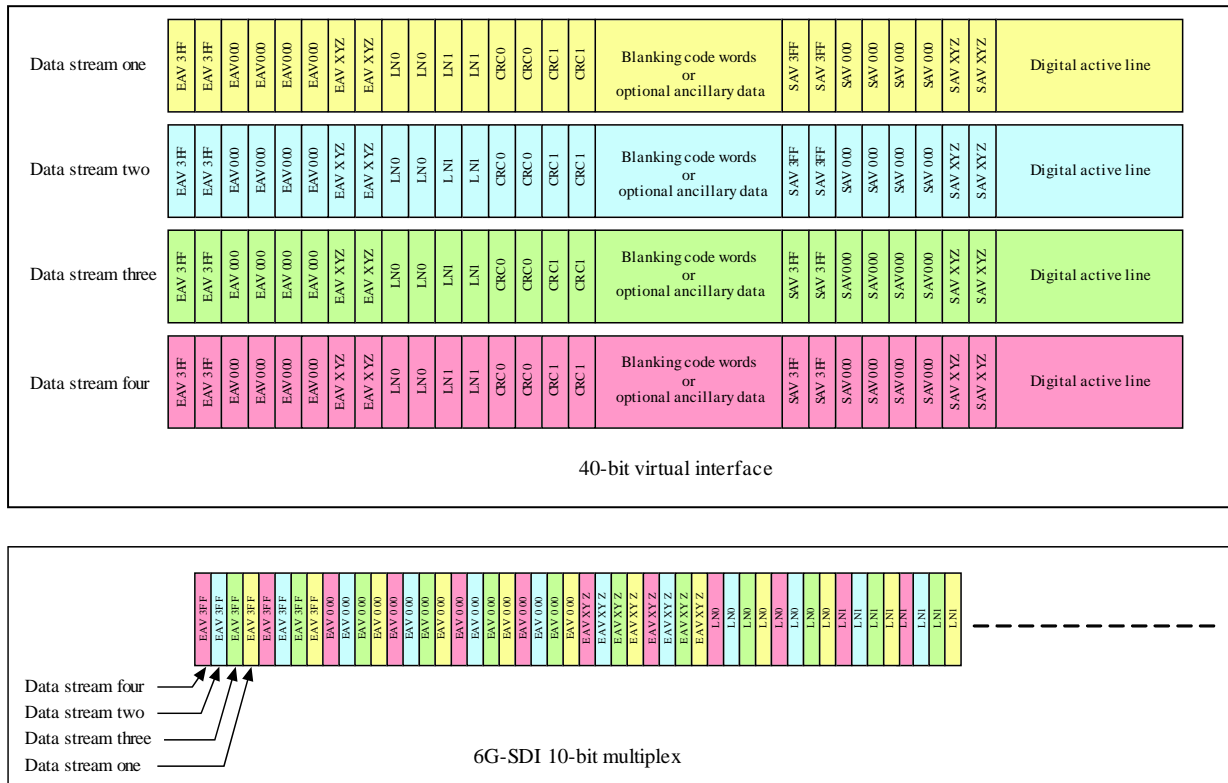

FIGURE 3-11
6G-SDI 10-bit Multiplex – Type 2



BT.2077-03-11

Each 6G-SDI 10-bit multiplexed interface should then be serialized to create a 6G-SDI serial interface.

The 6G-SDI 10-bit multiplexed interface made up of data streams one through four should be serialized as 6G-SDI serial Link 1.

The 6G-SDI 10-bit multiplexed interface made up of data streams five through eight should be serialized as 6G-SDI serial Link 2.

The 6G-SDI 10-bit multiplexed interface made up of data streams nine through twelve should be serialized as 6G-SDI serial Link 3.

The 6G-SDI 10-bit multiplexed interface made up of data streams thirteen through sixteen should be serialized as 6G-SDI serial Link 4.

5.2 6G-SDI serial interface

5.2.1 Sync-bit insertion

Repeating patterns of 3FF_h or 000_h in the 6G-SDI 10-bit parallel multiplex can result in a long run of ones and zeros feeding the scrambling polynomial.

To prevent long runs of ones and zeros, the 10-bit parallel multiplex data stream should be modified such that the two least significant bits, of repeated 3FF_h or 000_h code words should be replaced by the sync-bit values of 10b for 000_h words and 01b for 3FF_h words.

To ensure synchronization and word alignment can be reliably achieved in the receiver, one complete sequence of preambles – 3FF_h 000_h 000_h – should be retained without modification as shown in Fig. 3-12.

This Sync-bit insertion process should be reversed in the receiver restoring the original 3FF_h and 000_h data patterns.

FIGURE 3-12
Sync-bit insertion process

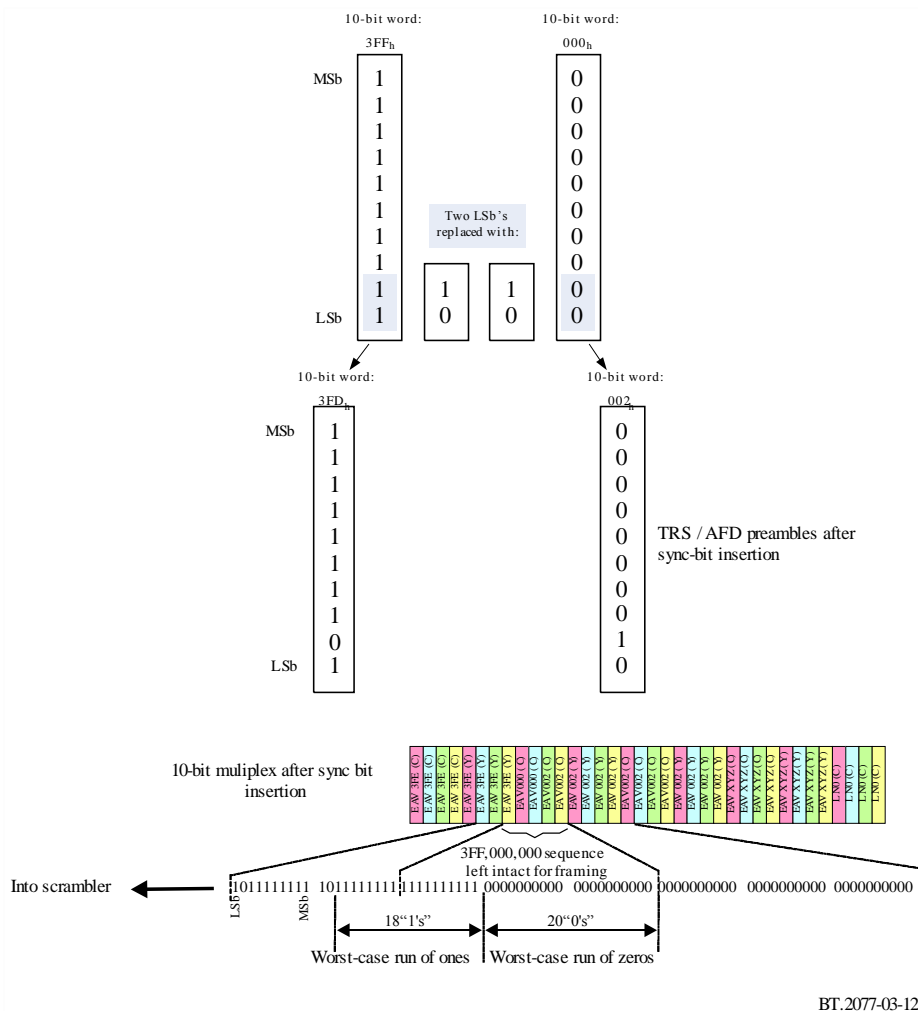

BT.2077-03-12

5.2.2 Channel coding and serialization

The channel coding and serializing should be according to Recommendation ITU-R BT.1120-8 § 4.2.2 “Serializing” and § 4.2.3 “Channel coding”

5.2.3 Serial clock

The serial clock frequency should be ten times the 10-bit parallel interface frequency. I.e. 5.94 GHz or 5.94/1.001 GHz.

5.2.4 Inter link delay

In the cases where an image is transported over multiple 6G links, the timing difference between the EAV/SAV of any 6G link to any other 6G link should not exceed 250 ns at the source.

6 Generation of 12G link signals

6.1 12G-SDI 10-bit Multiplex

See Tables 3-1 and 3-2 for data stream requirements for each source image format

Prior to serialization:

For signals where the virtual interface requires eight or more data streams:

Data streams one through eight should be multiplexed word-by-word into a 12G-SDI 10-bit interface.

The 10-bit interface should consist of a word multiplex of data streams one through eight, in the order data stream eight, data stream four, data stream six, data stream two, data stream seven, data stream three, data stream five, data stream one ... etc.

For signals where the virtual interface requires sixteen or more data streams:

Data streams nine through sixteen should be multiplexed word-by-word into a 12G-SDI 10-bit interface.

The 10-bit interface should consist of a word multiplex of data streams nine through sixteen, in the order data stream sixteen, data stream twelve, data stream fourteen, data stream ten, data stream fifteen data stream eleven, data stream thirteen data stream nine ... etc.

For signals where the virtual interface requires twenty four or more data streams:

Data streams seventeen through twenty four should be multiplexed word-by-word into a 12G-SDI 10-bit interface.

The 10-bit interface should consist of a word multiplex of data streams seventeen through twenty four, in the order data stream twenty four, data stream twenty, data stream twenty two, data stream eighteen, data stream twenty three, data stream nineteen, data stream twenty one data stream seventeen ... etc.

For signals where the virtual interface requires thirty two or more data streams:

Data streams twenty five through thirty two should be multiplexed word-by-word into a 12G-SDI 10-bit interface.

The 10-bit interface should consist of a word multiplex of data streams twenty five through thirty two, in the order data stream thirty two, data stream twenty eight, data stream thirty, data stream twenty six, data stream thirty one, data stream twenty seven, data stream twenty nine, data stream twenty five ... etc.

The 10-bit parallel interfaces so produced should have an interface frequency of 1 188 MHz or 1 188/1.001 MHz.

6.1.1 Type 1 and Type 2 10-bit parallel interfaces

As shown in Table 3-4 and Fig. 3-8, data streams for 30 Hz, 30/1.001 Hz, 25 Hz, 24 Hz and 24/1.001 Hz frame frequencies images with Image Structure 1 (4:2:2 or 4:2:0 10-bit) have a line structure with double length EAV, SAV, LN and CRC data components. These data streams, when multiplexed, result in a Type 2 10-bit parallel interface. Figure 3-14 shows the Type 2 10-bit parallel interface.

FIGURE 3-14
12G-SDI 10-bit Multiplex – Type 2

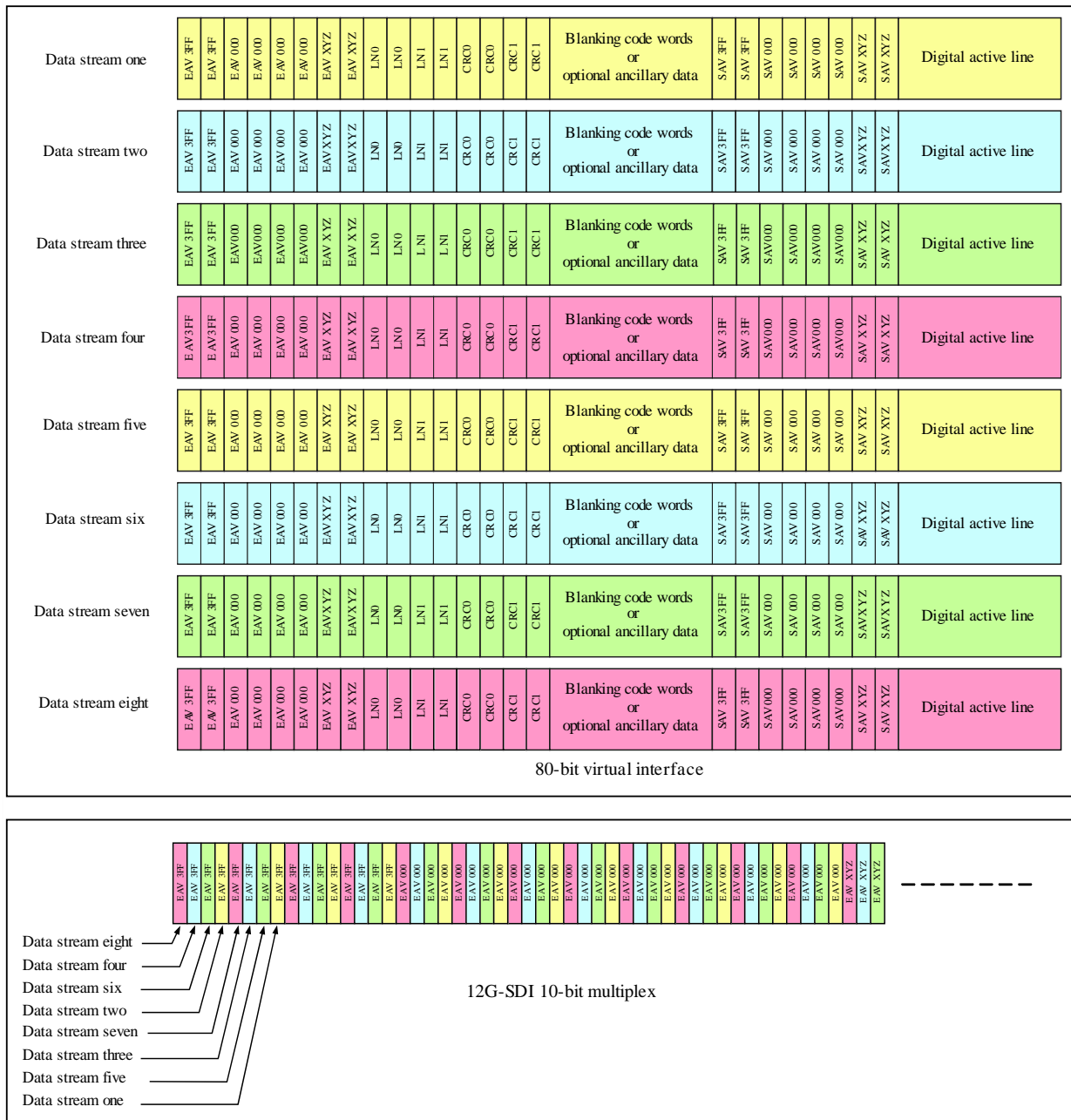

Each 12G-SDI 10-bit multiplexed interface should then be serialized to create a 12G-SDI serial interface.

The 12G-SDI 10-bit multiplexed interface made up of data streams one through eight should be serialized as 12G-SDI serial Link 1.

The 12G-SDI 10-bit multiplexed interface made up of data streams nine through sixteen should be serialized as 12G-SDI serial Link 2.

The 12G-SDI 10-bit multiplexed interface made up of data streams seventeen through twenty four should be serialized as 12G-SDI serial Link 3.

The 12G-SDI 10-bit multiplexed interface made up of data streams twenty five through thirty two should be serialized as 12G-SDI serial Link 4.

6.2 12G-SDI serial interface

6.2.1 Sync-bit insertion

Repeating patterns of 3FF_h or 000_h in the 12G-SDI 10-bit parallel multiplex can result in a long run of zeros feeding the scrambling polynomial.

To prevent long runs of zeros and ones, the 10-bit parallel multiplex data stream should be modified such that the two least significant bits of repeated 3FF_h or 000_h code words should be replaced by the sync-bit values of 10b for 000_h words and 01b for 3FF_h words.

To ensure synchronization and word alignment can be reliably achieved in the receiver, one complete sequence of preambles – 3FF_h, 000_h, 000_h – should be retained without modification as shown in Fig. 3-15.

This Sync-bit insertion process should be reversed in the receiver restoring the original 3FF_h and 000_h data patterns.

FIGURE 3-15

Sync-bit insertion process

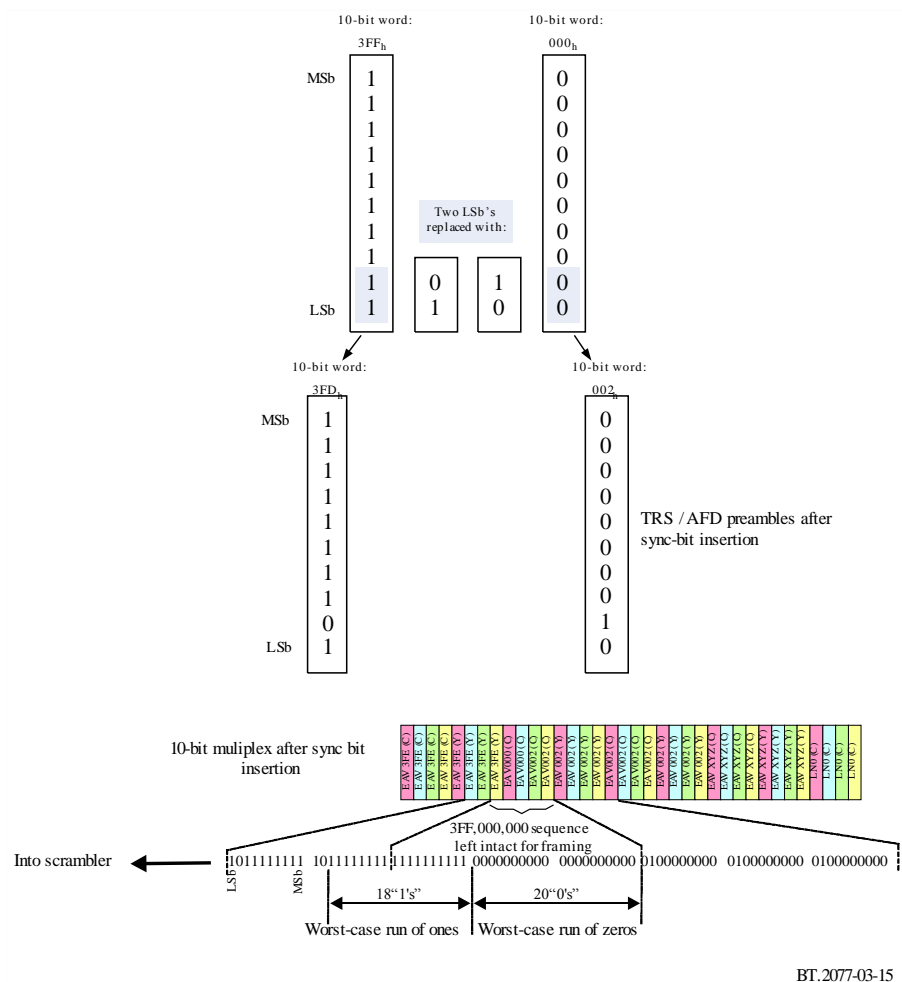

BT.2077-03-15

6.2.2 Channel coding and serialization

The channel coding and serializing should be according to Recommendation ITU-R BT.1120-8 § 4.2.2 “Serializing” and § 4.2.3 “Channel coding”.

6.2.3 Serial clock

The serial clock frequency should be ten times the 10-bit parallel interface frequency. I.e. 11.88 GHz or 11.88/1.001 GHz.

6.2.4 Inter link delay

In the cases where an image is transported over multiple 12G links, the timing difference between the EAV/SAV of any 12G link to any other 12G link should not exceed 250 ns at the source.

7 Generation of 24G link signals

7.1 24G-SDI 10-bit Multiplex

See Tables 3-1 and 3-2 for data stream requirements for each source image format.

Prior to serialization:

For signals where the virtual interface requires sixteen or more data streams:

Data streams one through sixteen should be multiplexed word-by-word into a 24G-SDI 10-bit interface.

The 10-bit interface should consist of a word multiplex of data streams one through sixteen, in the order data stream sixteen, data stream eight, data stream twelve, data stream four, data stream fourteen, data stream six, data stream ten, data stream two, data stream fifteen, data stream seven, data stream eleven, data stream three, data stream thirteen, data stream five, data stream nine, data stream one ... etc.

For signals where the virtual interface requires thirty two or more data streams:

Data streams seventeen through thirty two should be multiplexed word-by-word into a 24G-SDI 10-bit interface.

The 10-bit interface should consist of a word multiplex of data streams seventeen through thirty two, in the order data stream thirty two, data stream twenty four, data stream twenty eight, data stream twenty, data stream thirty, data stream twenty two, data stream twenty six, data stream eighteen, data stream thirty one, data stream twenty three, data stream twenty seven, data stream nineteen, data stream twenty nine, data stream twenty one, data stream twenty five, data stream seventeen ... etc.

For signals where the virtual interface requires forty eight or more data streams:

Data streams thirty three through forty eight should be multiplexed word-by-word into a 24G-SDI 10-bit interface.

The 10-bit interface should consist of a word multiplex of data streams thirty three through forty eight, in the order data stream forty eight, data stream forty, data stream forty two, data stream thirty six, data stream forty six, data stream thirty eight, data stream forty two, data stream thirty four, data stream forty nine, data stream thirty nine, data stream forty three, data stream thirty five, data stream forty five, data stream thirty seven, data stream forty one, data stream thirty three ... etc.

For signals where the virtual interface requires sixty four or more data streams:

Data streams forty nine through sixty four should be multiplexed word-by-word into a 24G-SDI 10-bit interface.

The 10-bit interface should consist of a word multiplex of data streams forty nine through sixty four, in the order data stream sixty four, data stream fifty six, data stream sixty, data stream fifty two, data stream sixty two, data stream fifty four, data stream fifty eight, data stream fifty, data stream sixty three, data stream fifty five, data stream fifty nine, data stream fifty one, data stream sixty one, data stream fifty three, data stream fifty seven, data stream forty nine ... etc.

The 10-bit parallel interfaces so produced should have an interface frequency of 2 376 MHz or 2 376/1.001 MHz.

7.1.1 Type 1 and Type 2 10-bit parallel interfaces

As shown in Table 3-4 and Fig. 3-8, data streams for 30 Hz, 30/1.001 Hz, 25 Hz, 24 Hz and 24/1.001 Hz frame frequencies images with Image Structure 1 (4:2:2 or 4:2:0 10-bit) have a line structure with double length EAV, SAV, LN and CRC data components. These data streams, when multiplexed, result in a Type 2 10-bit parallel interface. Figure 3-17 shows the Type 2 10-bit parallel interface.

All other images use a Type 1 10-bit parallel interface. Figure 3-16 shows the Type 1 10-bit parallel interface.

FIGURE 3-16
24G-SDI 10-bit Multiplex – Type 1

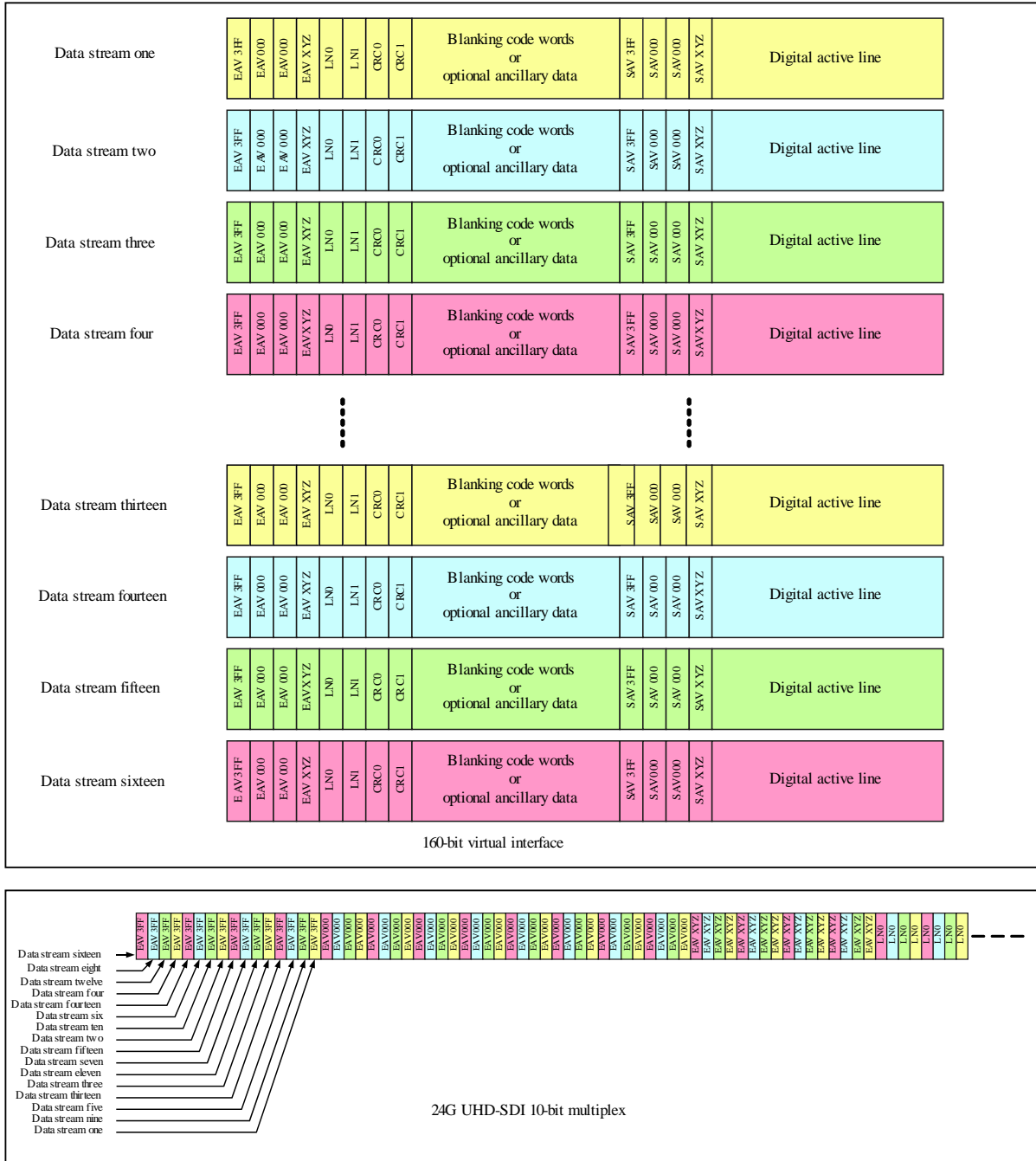
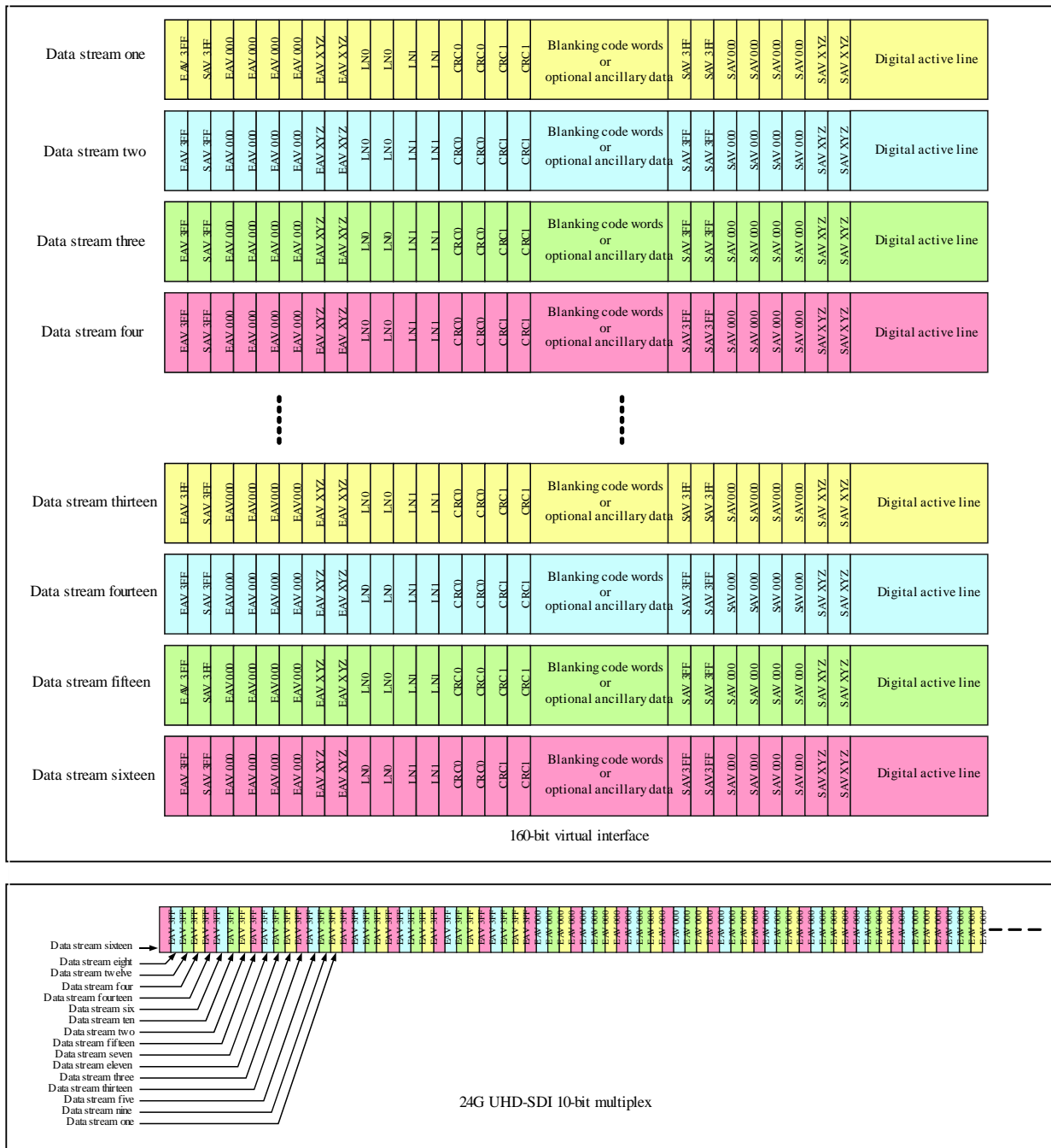

FIGURE 3-17
24G-SDI 10-bit Multiplex – Type 2



Each 24G-SDI 10-bit multiplexed interface should then be serialized to create a 24G-SDI serial interface.

The 24G-SDI 10-bit multiplexed interface made up of data streams one through sixteen should be serialized as 24G-SDI serial Link 1.

The 24G-SDI 10-bit multiplexed interface made up of data streams seventeen through thirty two should be serialized as 24G-SDI serial Link 2.

The 24G-SDI 10-bit multiplexed interface made up of data streams thirty three through forty eight should be serialized as 24G-SDI serial Link 3.

The 24G-SDI 10-bit multiplexed interface made up of data streams forty nine through sixty four should be serialized as 24G-SDI serial Link 4.

7.2 24G-SDI serial interface

7.2.1 Sync-bit insertion

Repeating patterns of 3FF_h or 000_h in the 24G-SDI 10-bit parallel multiplex can result in a long run of zeros feeding the scrambling polynomial.

To prevent long runs of zeros and ones, the 10-bit parallel multiplex data stream should be modified such that the two least significant bits of repeated 3FF_h or 000_h code words should be replaced by the sync-bit values of 10b for 000_h words and 01b for 3FF_h words.

To ensure synchronization and word alignment can be reliably achieved in the receiver, one complete sequence of preambles – 3FF_h, 000_h, 000_h – should be retained without modification as shown in Fig. 3-15.

This Sync-bit insertion process should be reversed in the receiver restoring the original 3FF_h and 000_h data patterns.

FIGURE 3-18
Sync-bit insertion process

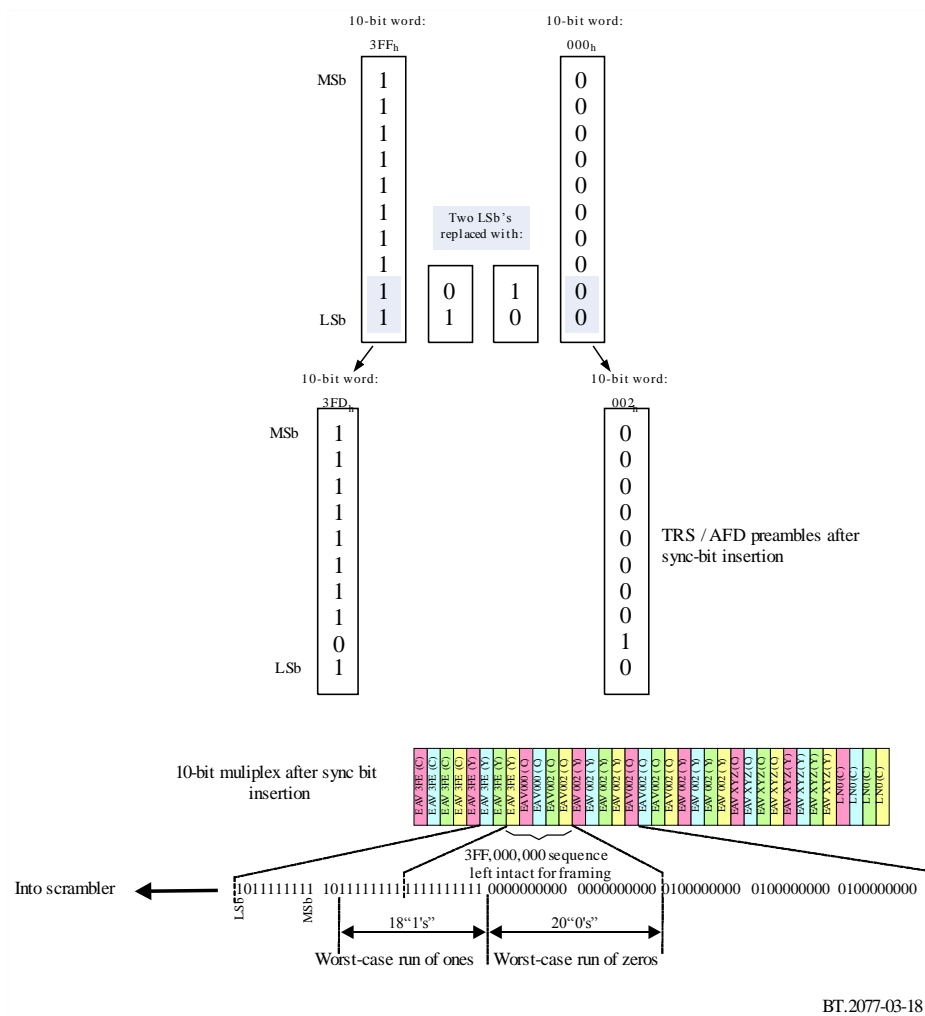

BT.2077-03-18

7.2.2 Channel coding and serialization

The channel coding and serializing should be according to Recommendation ITU-R BT.1120-8 § 4.2.2 “Serializing” and § 4.2.3 “Channel coding”.

7.2.3 Serial clock

The serial clock frequency should be ten times the 10-bit parallel interface frequency. I.e. 23.76 GHz or 23.76/1.001 GHz.

7.2.4 Inter link delay

In the cases where an image is transported over multiple 24G links, the timing difference between the EAV/SAV of any 24G link to any other 24G link should not exceed 250 ns at the source.

8 Coaxial cable interface

8.1 Generator signal levels and specifications

These specifications are defined for measurement of the serial output of a source derived from a parallel domain signal.

The output of the generator should be measured across a 75-ohm resistive load connected through one meter coaxial cable and 75 ohm BNC connectors⁸ meeting the requirements defined in § 8.2.

Figure 3-19 depicts the measurement dimensions for amplitude, rise-time and overshoot.

The generator should have an unbalanced output circuit with a source impedance of 75 ohms and should meet the return loss requirements defined in Table 3-12.

FIGURE 3-19

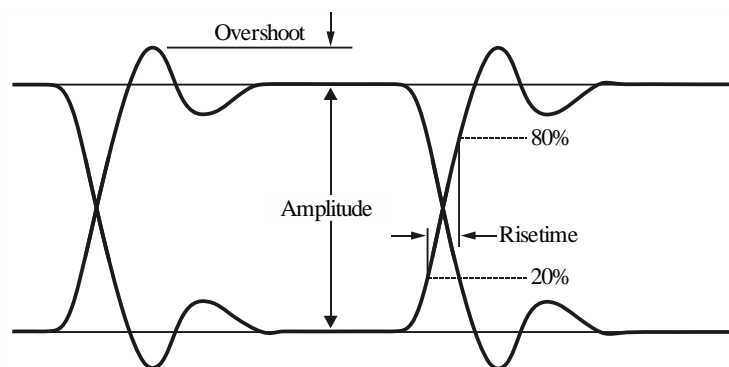
Waveform measurement Dimensions

BT.2077-03-19

The peak-to-peak signal amplitude should be $800 \text{ mV} \pm 10\%$.

The dc offset, as defined by the mid-amplitude point of the signal, should be nominally $0.0 \text{ V} \pm 0.5 \text{ V}$.

For a 6G interface the rise and fall times, determined between the 20% and 80% amplitude points should be no greater than 80 ps and should not differ by more than 30 ps.

For a 12G interface the rise and fall times, determined between the 20% and 80% amplitude points should be no greater than 45 ps and should not differ by more than 18 ps.

For a 24G interface the rise and fall times, determined between the 20% and 80% amplitude points should be no greater than 28 ps and should not differ by more than 8 ps.

Overshoot of the rising and falling edges of the waveform should not exceed 10% of the amplitude.

Output amplitude excursions due to signals with a significant dc component occurring for a horizontal line (pathological stress signal) should not exceed 50 mV above or below the average peak-to-peak signal envelope.

The jitter in the timing of the transitions of the data signal should have the values shown in Table 3-11 for compliance with Part 3 of this Recommendation.

1 UI corresponds to $1/f_c$. Specification of jitter and jitter measurements methods should comply with Recommendation ITU-R BT.1363 – Jitter specifications and methods for jitter measurement of bit-serial signals conforming to Recommendations ITU-R BT.656, ITU-R BT.799 and ITU-R BT.1120.

⁸ BNC connector refers to a connector which meets the mechanical specifications of IEC 61196-8 Annex A and the electrical specifications reflected in Part 3 of this Recommendation.

TABLE 3-11
Jitter specifications

Parameter	Value			Description
	6G	12G	24G	
F1	10 Hz	10 Hz	10 Hz	Timing jitter lower band edge (low frequency specification limit)
F3	100 KHz	100 KHz	100 KHz	Alignment Jitter lower band edge
F4	$> 1/10^{\text{th}}$ the clock rate (>594 MHz)	$> 1/10^{\text{th}}$ the clock rate (>1188 MHz)	$> 1/10^{\text{th}}$ the clock rate (>2356 MHz)	Upper band edge
A1	4 UI (673 psec)	8 UI (673 psec)	16 UI (673 psec)	Timing jitter expressed in unit interval
A2	0.3 UI (56 psec)	0.3 UI (28 psec)	0.3 UI (14 psec)	Alignment jitter
Test Signal	Colour bar test signal	Colour bar test signal	Colour bar test signal	Colour bar is chosen as a non-stressing test signal for jitter measurements.

8.2 Receiver signal levels and specifications

The receiver of the serial interface signal should present an impedance of 75 ohms and should meet the return loss requirements defined in § 8.2.1.

Receivers operating with input cable losses in the range of up to 40 dB at one-half the clock frequency are typical; however, receivers designed to work with greater or lesser signal attenuation are acceptable.

8.2.1 Return loss 6G interface

The generator and receiver unbalanced circuit should have a return loss that complies with the diagram of Fig. 3-20 in accordance with the parameters enumerated in Table 3-12.

FIGURE 3-20

Return loss 6G

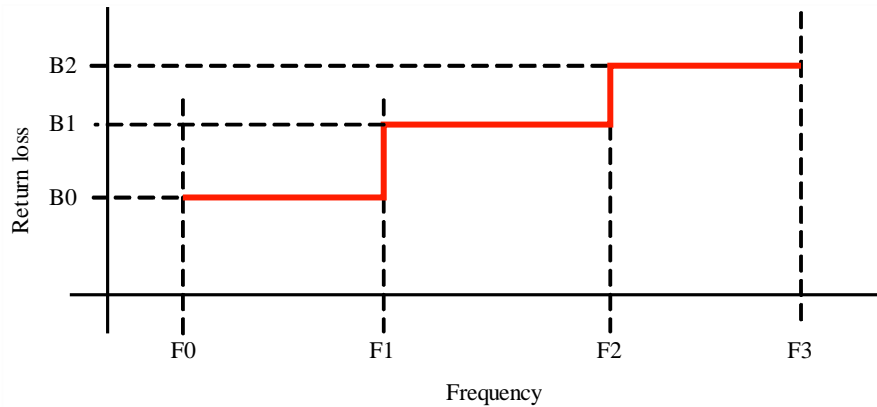

BT.2077-03-20

TABLE 3-12

Return loss parameters 6G

Parameter	Value	Description
F0	5 MHz	Return loss lower band edge
F1	1.485 GHz	Return loss transition lower band edge
F2	3 GHz	Return loss transition upper band edge
F3	6G Hz	Return loss upper band edge
B0	-15 dB	Return loss F0 to F1
B1	-10 dB	Return loss F1 to F2
B2	-7 dB	Return loss F2 to F3

8.2.2 Return loss 12G interface

The generator and receiver unbalanced circuit should have a return loss that complies with the diagram of Fig. 3-21 in accordance with the parameters enumerated in Table 3-13.

FIGURE 3-21
Return loss 12G

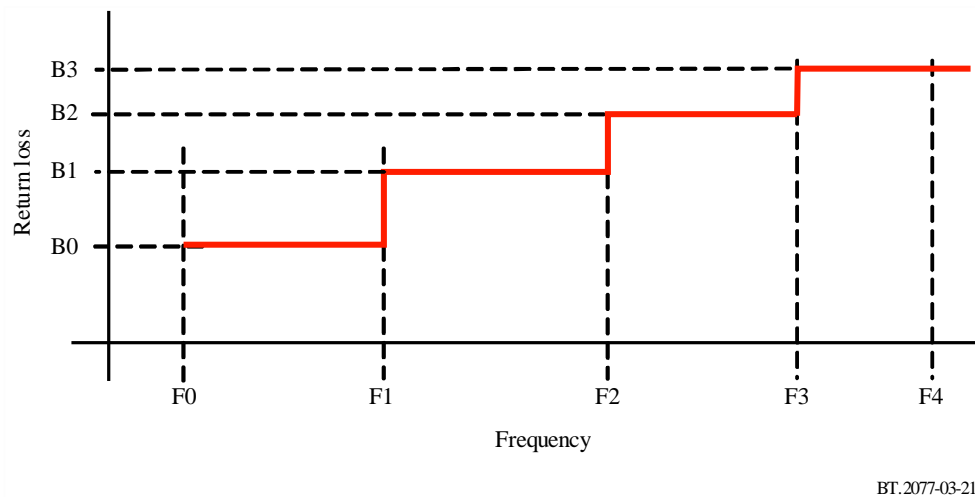

BT.2077-03-21

TABLE 3-13
Return loss parameters 12G

Parameter	Value	Description
F0	5 MHz	Return loss lower band edge
F1	1.485 GHz	Return loss transition lower band edge
F2	3 GHz	Return loss mid band edge
F3	6 GHz	Return loss mid band upper edge
F4	12 GHz	Return loss upper band edge
B0	-15 dB	Return loss f0 to f1
B1	-10 dB	Return loss f1 to f2
B2	-7 dB	Return loss f2 to f3
B3	-4 dB	Return loss f3 to f4

8.2.3 Return loss 24G interface

The generator and receiver unbalanced circuit should have a return loss that complies with the diagram of Fig. 3-22 in accordance with the parameters enumerated in Table 3-14.

FIGURE 3-22
Return loss 24G

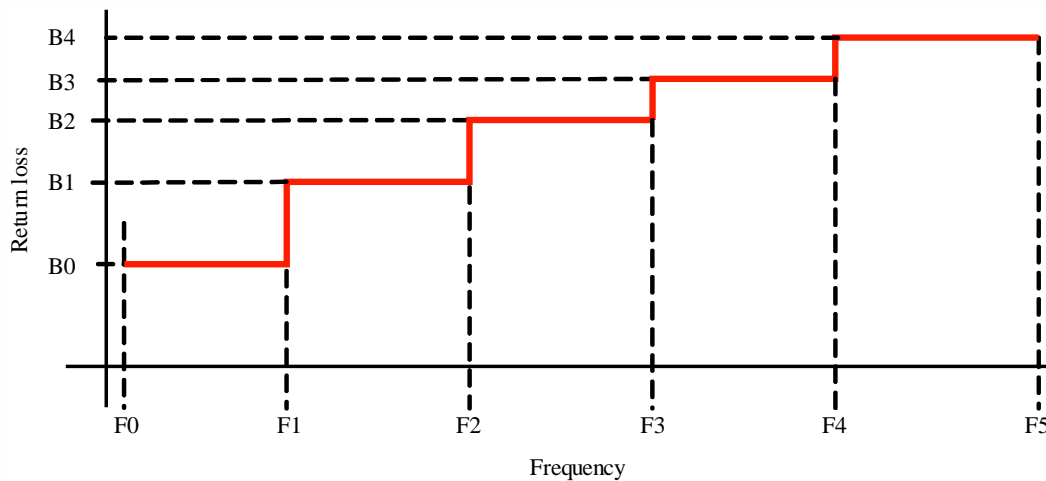

BT.2077-03-22

TABLE 3-14
Return loss parameters 24G

Parameter	Value	Description
F0	5 MHz	Return loss lower band edge
F1	1.485 GHz	Return loss transition lower band edge
F2	3 GHz	Return loss mid band edge
F3	6 GHz	Return loss mid band upper edge
F4	12 GHz	Return loss upper mid band upper edge
F5	24 GHz	Return loss upper band edge
B0	-15 dB	Return loss f0 to f1
B1	-10 dB	Return loss f1 to f2
B2	-7 dB	Return loss f2 to f3
B3	-4 dB	Return loss f3 to f4
B4	-2 dB	Return loss f4 to f5

9 Optical interface

Recommendation ITU-R BT.1367 provides information relating to the use of single and multi-mode fibre optical cable carrying the serial data defined in Recommendations ITU-R BT.656, ITU-R BT.799 and ITU-R BT.1120 (270 Mbit/s through 2.97 Gbit/s).

This section expands Recommendation ITU-R BT. 1367 for carrying the 6G, 12G and 24G serial data defined in the coaxial cable section above.

Physical packaging and connectors for transmitter and receiver units

The Optical interface should be compliant with the Tx and Rx unit optical domain connectors and Polish requirements as defined in Recommendation ITU-R BT.1367.

In accordance with Recommendation ITU-R BT.1367, the preferred Tx and Rx unit optical domain connectors and their mating input and output cable sections should be LC/PC.

9.1 Transmitter unit

The transmitter unit should be compliant with the low-power (short-haul), medium-power (medium-haul) and high-power (long-haul) link parameters defined in Recommendation ITU-R BT.1367 with the following exceptions:

- Rise and fall times – measured following a fourth-order Bessel-Thompson filter with a 3 dB point at $0.75 \times$ data rate – should be as specified in the coaxial cable section above for the electrical rise / fall time requirements.
- Maximum Intrinsic jitter (optical) should be as specified in the coaxial cable section above.
- Maximum spectral line width between half power points for single mode low power 6G and 12G links should be 4 nm.
- Maximum spectral line width between half power points for single mode 24G links at all power levels should be 1 nm.
- Maximum optical power for medium power 6G and 12G links should be +0.5 dBm.
- Maximum optical power for medium power 24G links should be +3 dBm.
- Minimum optical power for medium power 24G links should be –1 dBm.

9.1.1 Transmitter unit labelling

The transmitter unit labelling should be compliant with the transmitter unit labelling requirements as defined in Recommendation ITU-R BT.1367 with the following exceptions:

- The element <signal type> should support the following additional value:
 - “E” to indicate support for 6G signals
 - “F” to indicate support for 12G signals
 - “G” to indicate support for 24G signals

9.2 Receiver unit

The receiver unit should be compliant with the requirements as defined in Recommendation ITU-R BT.1367 with the following exceptions:

- The receiver unit output electrical signal should be compliant with the coaxial cable section above when receiving an optical signal in accordance with Recommendation ITU-R BT.1367 Table 2 – Optical receiver input signal specifications.
- Maximum jitter should be as specified in the coaxial cable section above.
- The minimum input power as defined in Recommendation ITU-R BT.1367 Table 2 – Optical receiver input signal specifications should be:
 - –14 dBm for 6G
 - –14 dBm for 12G
 - –9 dBm for 24G

- The minimum input overload power as defined in Recommendation ITU-R BT.1367 Table 2 – Optical receiver input signal specifications should be +0.5 dBm for optical receivers compliant with Part 3 of this Recommendation.

9.2.2 Receiver unit labelling

The receiver unit labelling should be compliant with the receiver unit labelling requirements as defined in Recommendation ITU-R BT.1367 with the following exceptions:

- The element <signal type> should support the following additional value:
 - “E” to indicate support for 6G signals
 - “F” to indicate support for 12G signals
 - “G” to indicate support for 24G signals

Optical fibre circuit and connector specifications

For compliance with Part 3 of this Recommendation, optical fibre circuits and connectors, deployed in an optical SDI network, should be selected in accordance with the specifications (Fibre types and connector return loss), defined in Recommendation ITU-R BT.1367.

9.2.3 Selection of wavelengths⁹

For single link or multi-link using multiple fibres with single wavelength per fibre:

- Nominal central wavelength for single mode fibre: 1 311 nm
- Nominal central wavelength for multimode fibre: 850 nm.

For multi-link using CWDM:

TABLE 3-15

Recommended nominal central wavelengths

Number of links	λ for Link 1	λ for Link 2	λ for Link 3	λ for Link 4	λ for Link 5	λ for Link 6	λ for Link 7	λ for Link 8
Dual	1 271	1 291	–	–	–	–	–	–
Quad	1 271	1 291	1 311	1 331	–	–	–	–
Octal	1 271	1 291	1 311	1 331	1 351	1 371	1 391	1 411

NOTE: Recommendation ITU-R BT.1367-2 Appendix F describes the type of fibre to use for octal-link applications when Link 7 and Link 8 are used

⁹ These links are generally used for point-to-point connections within a facility and users or manufacturers may choose to use alternative wavelengths.

Attachment 1

to Part 3 (Informative)

Image division by image structure

For the 2-sample interleave division process used in Part 3 of this Recommendation, the sub-image structure for 4:4:4, 4:4:4+4, 4:2:2 and 4:2:2+4 image structures is the same as the source image structure.

Figure 3-1-1 shows an example of a 2 160-line image with 4:4:4 or 4:4:4+4 image structure divided to four 1 080-line images

FIGURE 3-1-1

4:4:4(+4) Image Division

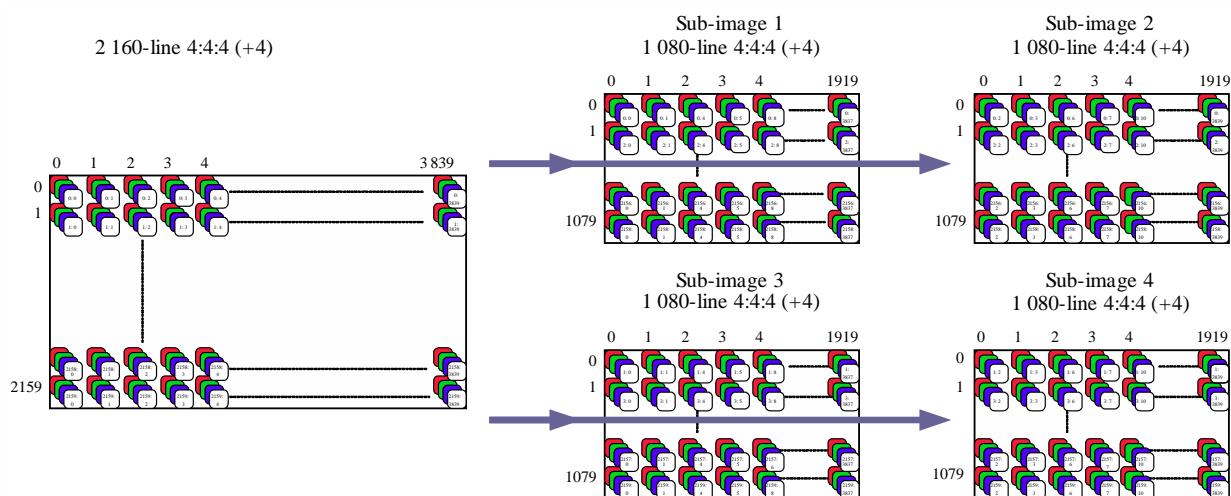

BT.2077-03-1-01

Figure 3-1-2 shows an example of a 2 160-line 4:2:2 image structure divided to four sub-images.

FIGURE 3-1-2

4:2:2 Image Division

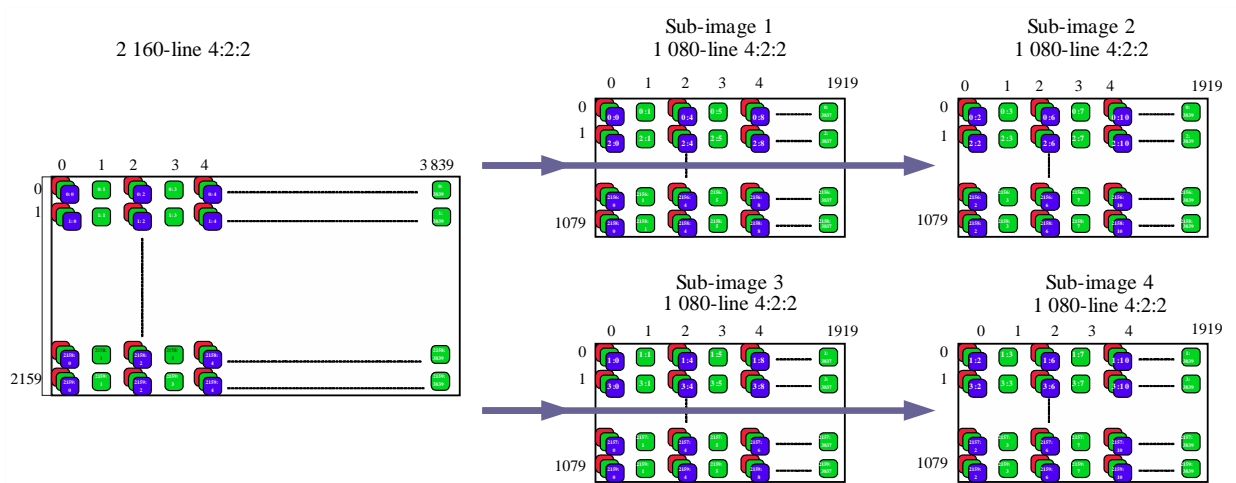

BT.2077-03-1-02

As the 2-sample interleave division process assigns alternate lines to different sub-images, source images with a 4:2:0 image structure do not result in sub-images with a 4:2:0 image structure.

The even lines in the source image contain Y and C components, with the odd lines having Y components only.

The 2-sample division process results in sub-images 1 and 2 having Y and C components in a 4:2:2 image structure, and sub-images 3 and 4 having Y components only.

Figure 3-1-3 shows an example of a 2 160-line 4:2:0 image structure divided to four sub-images.

FIGURE 3-1-3

4:2:0 Image Division

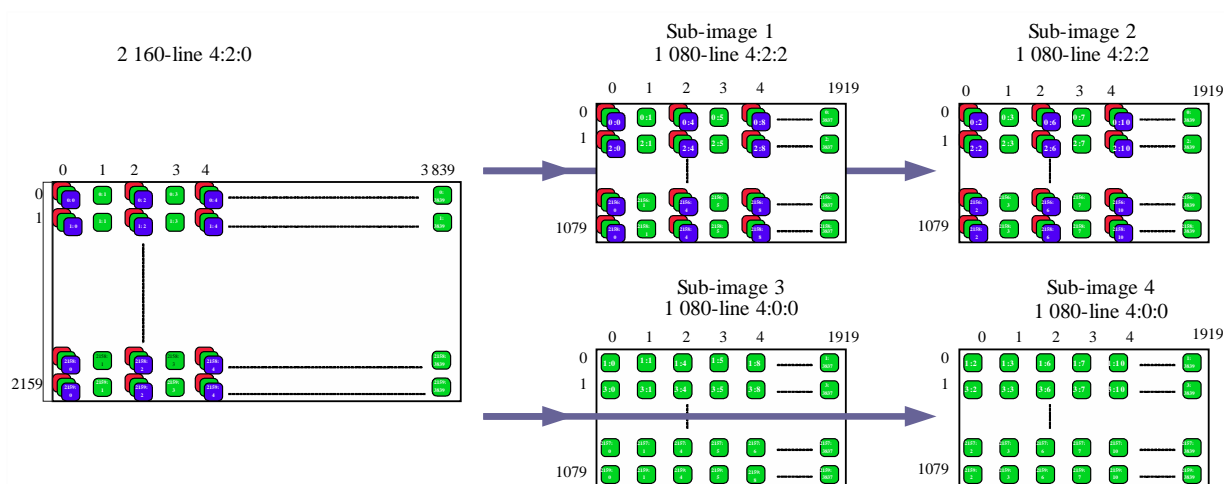

BT.2077-03-1-03

The resulting sub-images will all be transported in a 4:2:2 multiplex. The missing C components in the multiplex are assigned the data values which represent zero colour-difference. These are 200h in the case of a 10-bit system or 800h in the case of a 12-bit system.

In the case of 4 320-line source images, the division shown in Fig. 3-1-3 takes place when the 4 320-line image is divided to four 2 160-line intermediate sub-images, so that 2 160-line intermediate sub-images 1 and 2 have 4:2:2 C components and 2 160-line intermediate sub-images 3 and 4 have their C components assigned the zero colour-difference values. When the 2 160-line intermediate sub-images are each divided to four 1 080-line sub-images:

- 1 080-line sub-images 1 to 4 inclusive, which are divided from 2 160-line intermediate sub-image 1, and 1 080-line sub-images 5 to 8 inclusive, which are divided from 2 160-line intermediate sub-image 2, contain all of the C components from the 4 320-line source image in a 4:2:2 image structure
- 1 080-line sub-images 9 to 12 inclusive, which are divided from 2 160-line intermediate sub-image 3, and 1 080-line sub-images 13 to 16 inclusive, which are divided from 2 160-line intermediate sub-image 4, contain all of the zero colour-difference value C components.

Attachment 2

to Part 3 (informative)

The use of a gearbox to convert between interfaces

As shown in Figs 3-1 and 3-2, a source image is mapped to a number of data streams, and these data streams are then multiplexed to one or more 6 Gb/s links at four data streams per link, or to one or more 12 Gb/s links at eight data streams per link, or to one or more 24 Gb/s links at 16 data streams per link.

The virtual interface for each image format, including all video ancillary and audio data, is identical except for the PID values, which have a different Byte 1 to reflect the output interface type and a different Byte 4 to indicate the link number.

A simple device to take in, for example, a quad-link 6G interface signal and output a single link 24G interface signal is clearly possible. This device is called a gearbox.

The functions of the gearbox are:

- 1) To multiplex two or four inputs to a single output or to demultiplex a single input to two or four outputs.
- 2) To modify Byte 1 of the PID to indicate the output interface type.
- 3) To modify Byte 4 of the PID to indicate the number of the output link.

This gearbox could be a separate device, or could be incorporated in the processing equipment's or exchange equipment's inputs or outputs.
