



Recommendation ITU-R BT.2016-2
(12/2020)

**Error-correction, data framing, modulation
and emission methods for terrestrial
multimedia broadcasting for mobile
reception using handheld receivers
in VHF/UHF bands**

BT Series
Broadcasting service
(television)

Foreword

The role of the Radiocommunication Sector is to ensure the rational, equitable, efficient and economical use of the radio-frequency spectrum by all radiocommunication services, including satellite services, and carry out studies without limit of frequency range on the basis of which Recommendations are adopted.

The regulatory and policy functions of the Radiocommunication Sector are performed by World and Regional Radiocommunication Conferences and Radiocommunication Assemblies supported by Study Groups.

Policy on Intellectual Property Right (IPR)

ITU-R policy on IPR is described in the Common Patent Policy for ITU-T/ITU-R/ISO/IEC referenced in Resolution ITU-R 1. Forms to be used for the submission of patent statements and licensing declarations by patent holders are available from <http://www.itu.int/ITU-R/go/patents/en> where the Guidelines for Implementation of the Common Patent Policy for ITU-T/ITU-R/ISO/IEC and the ITU-R patent information database can also be found.

Series of ITU-R Recommendations

(Also available online at <http://www.itu.int/publ/R-REC/en>)

Series	Title
BO	Satellite delivery
BR	Recording for production, archival and play-out; film for television
BS	Broadcasting service (sound)
BT	Broadcasting service (television)
F	Fixed service
M	Mobile, radiodetermination, amateur and related satellite services
P	Radiowave propagation
RA	Radio astronomy
RS	Remote sensing systems
S	Fixed-satellite service
SA	Space applications and meteorology
SF	Frequency sharing and coordination between fixed-satellite and fixed service systems
SM	Spectrum management
SNG	Satellite news gathering
TF	Time signals and frequency standards emissions
V	Vocabulary and related subjects

Note: This ITU-R Recommendation was approved in English under the procedure detailed in Resolution ITU-R 1.

Electronic Publication
Geneva, 2020

© ITU 2020

All rights reserved. No part of this publication may be reproduced, by any means whatsoever, without written permission of ITU.

RECOMMENDATION ITU-R BT.2016-2

Error-correction, data framing, modulation and emission methods for terrestrial multimedia broadcasting for mobile reception using handheld receivers in VHF/UHF bands

(2012-2013-2020)

Scope

This Recommendation defines error-correction, data framing, modulation and emission methods for terrestrial multimedia broadcasting for mobile reception using handheld receivers in the VHF/UHF bands.

Keywords

Error correction, data framing, modulation characteristics, emission methods, terrestrial multimedia broadcasting, mobile reception, handheld

The ITU Radiocommunication Assembly,

considering

- a) that digital multimedia broadcasting systems have been implemented in many countries or are planned to be introduced, using the inherent capability of digital broadcasting systems;
- b) that terrestrial emission systems for mobile reception using handheld receivers require specific technical characteristics due to peculiar propagation characteristics;
- c) that the interoperability between multimedia and digital television and sound broadcasting systems could offer the possibility for the reuse of the existing broadcast infrastructure for multimedia services;
- d) that Recommendations ITU-R BT.1306 and ITU-R BT.1877 specify error-correction, data framing, modulation and emission methods for digital terrestrial television broadcasting;
- e) that Recommendation ITU-R BS.1114 specifies error-correction, data framing, modulation and emission methods as well as higher-layer systems characteristics for digital terrestrial sound broadcasting;
- f) that Recommendation ITU-R BT.1833 and Report ITU-R BT.2049 describe end user requirements and higher-layer systems characteristics for multimedia broadcasting systems for mobile reception using handheld receivers,

recommends

1 that administrations wishing to introduce terrestrial multimedia broadcasting for mobile reception using handheld receivers in the VHF/UHF bands should use one or several (depending on the multimedia broadcasting market) of the systems comprising error-correction, framing, modulation and emission methods outlined in Annex 1.

NOTE – Tables 1 and 2 of Annex 1 can be used to evaluate the respective characteristics of the systems in selecting a specific system.

Annex 1

Table 1 provides data about emission systems for terrestrial multimedia broadcasting for mobile reception using handheld receivers in the VHF/UHF bands. Supplemental information for the systems can be found in Attachments 1, 2 and 3.

Table 2 provides technical features of each system described in Table 1 that concern several aspects relevant to implementation and deployment.

TABLE 1
Parameters for emission systems

	Parameters	Multimedia System A	Multimedia System F	Multimedia System I	Multimedia System H	Multimedia System T2	Multimedia System R
1	Channel bandwidths	1.712 MHz	$1/14 \times n$ of a) 6 MHz b) 7 MHz c) 8 MHz $n \geq 1$ (*2-1)	a) 1.7 MHz b) 5 MHz c) 6 MHz d) 7 MHz e) 8 MHz	a) 5 MHz b) 6 MHz c) 7 MHz d) 8 MHz	a) 1.7 MHz b) 5 MHz c) 6 MHz d) 7 MHz e) 8 MHz	a) 100 kHz b) 200 kHz c) 250 kHz
2	Used bandwidth	1.536 MHz	“Subcarrier spacing” (see item 5) + $1/14 \times n$ \times a) 6 MHz b) 7 MHz c) 8 MHz $n \geq 1$ (*2-1)	a) 1.52 MHz b) 4.75 MHz c) 5.71 MHz d) 6.66 MHz 7.61 MHz	a) 4.75 MHz b) 5.71 MHz c) 6.66 MHz d) 7.61 MHz	a) 1.52 MHz b) 4.75 MHz c) 5.71 MHz d) 6.66 MHz e) 7.61 MHz	a) 96.0 kHz b) 185.6 kHz c) 246.2 kHz
3	Number of segments	1	$n \geq 1$ (*2-1)		Configurable number of time slices per bandwidth	Configurable	1
4	Number of subcarriers per segment	192 384 768 1 536	108 (Mode 1) 216 (Mode 2) 432 (Mode 3)	853 (1k mode) 1 705 (2k mode) 3 409 (4k mode) 6 817 (8k mode)	1 705 (2k mode) 3 409 (4k mode) 6 817 (8k mode)	1 705 (2k mode) 3 409 (4k mode) 6 817 (8k mode) 13 633 (16k mode)	215 (100 kHz) 439 (200 kHz) 553 (250 kHz)

TABLE 1 (continued)

	Parameters	Multimedia System A	Multimedia System F	Multimedia System I	Multimedia System H	Multimedia System T2	Multimedia System R
5	Subcarrier spacing	a) 8 kHz b) 4 kHz c) 2 kHz d) 1 kHz	a) 3.968 kHz (Mode 1) ^(*2-2) , 1.984 kHz (Mode 2), 0.992 kHz (Mode 3) b) 4.629 kHz (Mode 1), 2.314 kHz (Mode 2), 1.157 kHz (Mode 3) c) 5.291 kHz (Mode 1), 2.645 kHz (Mode 2), 1.322 kHz (Mode 3)	a) 1 786 kHz (1k) b) 5 580.322 Hz (1k), 2 790.179 Hz (2k), 1 395.089 Hz (4k), 697.545 Hz (8k) c) 6 696.42 Hz (1k), 3 348.21 Hz (2k), 1 674.11 Hz (4k), 837.05 Hz (8k) d) 7 812 Hz (1k), 3 906 Hz (2k), 1 953 Hz (4k), 976 Hz (8k) e) 8 929 Hz (1k), 4 464 Hz (2k), 2 232 Hz (4k), 1 116 Hz (8k)	a) 2 790.179 Hz (2k), 1 395.089 Hz (4k), 697.545 Hz (8k) b) 3 348.21 Hz (2k), 1 674.11 Hz (4k), 837.05 Hz (8k) c) 3 906 Hz (2k), 1 953 Hz (4k), 976 Hz (8k) d) 4 464 Hz (2k), 2 232 Hz (4k), 1 116 Hz (8k)	a) 901 Hz (2k mode), 450 Hz (4k mode), 225 Hz (8k mode), 113 Hz (16k mode) b) 2 790 Hz (2k mode), 1 395 Hz (4k mode), 698 Hz (8k mode), 349 Hz (16k mode) c) 3 348 Hz (2k mode), 1 674 Hz (4k mode), 837 Hz (8k mode), 419 Hz (16k mode) d) 3 906 Hz (2k mode), 1 953 Hz (4k mode), 977 Hz (8k mode), 488 Hz (16k mode) e) 4 464 Hz (2k mode), 2 232 Hz (4k mode), 1 116 Hz (8k mode), 558 Hz (16k mode)	4 000/9 Hz

TABLE 1 (continued)

	Parameters	Multimedia System A	Multimedia System F	Multimedia System I	Multimedia System H	Multimedia System T2	Multimedia System R
6	Active symbol duration	a) 156 μs b) 312 μs c) 623 μs d) 1 246 μs	a) 252 μs (Mode 1) (*2-2), 504 μs (Mode 2), 1 008 μs (Mode 3) b) 216 μs (Mode 1), 432 μs (Mode 2), 864 μs (Mode 3) c) 189 μs (Mode 1), 378 μs (Mode 2), 756 μs (Mode 3)	a) 560 μs (1k) b) 179.2 μs (1k), 358.40 μs (2k), 716.80 μs (4k), 1 433.60 μs (8k) c) 149.33 μs (1k), 298.67 μs (2k), 597.33 μs (4k), 1 194.67 μs (8k) d) 2 128 μs (1k), 256 μs (2k), 512 μs (4k), 1 024 μs (8k) e) 112 μs (1k), 224 μs (2k), 448 μs (4k), 896 μs (8k)	a) 358.40 μs (2k), 716.80 μs (4k), 1 433.60 μs (8k) b) 298.67 μs (2k), 597.33 μs (4k), 1 194.67 μs (8k) c) 256 μs (2k), 512 μs (4k), 1 024 μs (8k) d) 224 μs (2k), 448 μs (4k), 896 μs (8k)	a) 1 109.98 μs (2k) 2 219.97 μs (4k) 4 439.94 μs (8k) b) 358.4 μs (2k) 716.8 μs (4k) 1 433.6 μs (8k) 2 867.2 μs (16k) c) 298.67 μs (2k) 597.33 μs (4k) 1 194.67 μs (8k) 2 389.33 μs (16k) d) 256 μs (2k) 512 μs (4k) 1 024 μs (8k) 2 048 μs (16k) e) 224 μs (2k) 448 μs (4k) 896 μs (8k) 1 792 μs (16k)	2.25 ms
7	Guard interval duration or guard interval ratio	a) 31 μs b) 62 μs c) 123 μs d) 246 μs	1/32, 1/16, 1/8, 1/4 of “active symbol duration” (see item 6)	1/32, 1/16, 1/8, 1/4 of active symbol duration	1/32, 1/16, 1/8, 1/4 of active symbol duration	1/128, 1/32, 1/16, 19/256, 1/8, 19/128, 1/4 of active symbol duration	1/8 of active symbol duration
8	Transmission unit (frame) duration	96 ms 48 ms 24 ms	204 OFDM symbols (Symbol duration = guard interval duration + active symbol duration)	68 OFDM symbols. One super-frame consists of 4 frames	68 OFDM symbols. One super-frame consists of 4 frames	Flexible with possibility of changing on frame-by-frame basis. Max 250 ms	41 OFDM symbols (103.78125 ms)

TABLE 1 (continued)

	Parameters	Multimedia System A	Multimedia System F	Multimedia System I	Multimedia System H	Multimedia System T2	Multimedia System R
9	Time/frequency synchronization	Null symbol and centre frequency and phase reference symbol	Pilot carriers	Pilot carriers	Guard interval/ Pilot carriers	P1 symbol/Guard interval/Pilot carriers	Guard interval/ Pilot carriers
10	Modulation methods	T-DMB: COFDM-DQPSK AT-DMB: COFDM-DQPSK COFDM-BPSK over DQPSK COFDM-QPSK over DQPSK	DQPSK, QPSK, 16-QAM, 64-QAM	QPSK, 16-QAM	QPSK, 16-QAM, 64-QAM, MR-16-QAM, MR-64-QAM	QPSK, 16-QAM, 64-QAM with or without constellation rotation specific for each physical layer pipe	QPSK, 16-QAM, 64-QAM (main service channel)
11	Inner channel coding	T-DMB: Convolutional code (1/4 to 3/4) AT-DMB: Convolutional code + Turbo code (1/4 to 1/2)	Convolution code, Mother rate 1/2 with 64 states. Puncturing to rate 2/3, 3/4, 5/6, 7/8	Turbo Code from 3GPP2 with mother information block size of 12 282 bits. Rates obtained by puncturing: 1/5, 2/9, 1/4, 2/7, 1/3, 2/5, 1/2, 2/3	Convolutional code, mother rate 1/2 with 64 states. Puncturing to rate 2/3, 3/4, 5/6, 7/8	LDPC code with code rates 1/3, 2/5, 1/2, 3/5, 2/3, 3/4	LDPC code with approximate code rates 1/2, 2/3, 3/4 (main service channel)

TABLE 1 (continued)

	Parameters	Multimedia System A	Multimedia System F	Multimedia System I	Multimedia System H	Multimedia System T2	Multimedia System R
12	Inner interleaving	Time interleaving and frequency interleaving	Frequency interleaving: Intra and inter segments interleaving Time interleaving: Symbol-wise convolutional interleaving 0, 380, 760, 1 520, 3 040 symbols (Mode 1) ^(*) 0, 190, 380, 760, 1 520 symbols (Mode 2) 0, 95, 190, 380, 760 symbols (Mode 3)	– Frequency interleaving – Time interleaving: Forney with 48 branches QPSK: 320/9 600 ms 16QAM:160/4 800 ms	Bit interleaving, combined with native or in-depth symbol interleaving	Cell, Time and Frequency interleaving	Bit, cell, time and frequency interleaving
13	Outer channel coding	RS (204, 188, T=8) code for video service and scalable video service	RS (204, 188, T=8)		Outer Code: RS (204, 188, T = 8) IP outer channel code: MPE-FEC RS (255,191)	BCH (16 200, x, t), there x – depends on LDPC code rate. Error correction capability t = 12 errors	BCH (n, k, t); n, k depends on channel bandwidth, LDPC code rate; error correction capability t = 10 errors (main service channel)
14	Outer Interleaving	Convolutional interleaving for video service and scalable video service	Byte-wise convolutional interleaving, I = 12	Byte-wise convolutional interleaving, I = 12		Bit (parity and column twist) interleaving	

TABLE 1 (*end*)

	Parameters	Multimedia System A	Multimedia System F	Multimedia System I	Multimedia System H	Multimedia System T2	Multimedia System R
15	Net data rates	<ul style="list-style-type: none"> T-DMB: 0.576 to 1.728 Mbit/s AT-DMB: 0.864 to 2.304 Mbit/s at BPSK over DQPSK AT-DMB: 1.152 to 2.88 Mbit/s at QPSK over DQPSK 	$n \times$ a) 0.281 to 1.787 Mbit/s b) 0.328 to 2.085 Mbit/s c) 0.374 to 2.383 Mbit/s	At MPEG-TS level and starting from the lower code rate with GI 1/4 to the higher rate with GI 1/32: a) 0,42 to 3.447 Mbit/s b) 1.332 to 10,772 Mbit/s c) 1.60 to 12.95 Mbit/s d) 1.868 to 15.103 Mbit/s e) 2.135 to 17.257 Mbit/s	Depends on MPE-FEC rate. For MPE-FEC rate 3/4: a) 2.33-14.89 Mbit/s b) 2.80-17.87 Mbit/s c) 3.27-20.84 Mbit/s d) 3.74-23.82 Mbit/s	Max available input bit-rate in case of Transport stream is 4 Mbit/s	Depending on modulation and code rate for different channel bandwidth: a) 75-341 kbit/s (100 kHz) b) 155-703 kbit/s (200 kHz) c) 196-888 kbit/s (250 kHz)
Reference		Attachment 1	Attachment 2	Attachment 3	Attachment 4	Attachment 5	Attachment 6

(*2-1) The number of segments “n” is determined by the available bandwidth.

(*2-2) Modes 1, 2 and 3 can be selected by the scale of the single frequency network (SFN) and the types of service reception such as fixed or mobile. Mode 1 can be used for single transmission operation, or for small single frequency network. This mode is suitable for mobile reception. Mode 3 can be used for large single frequency network. This mode is suitable for fixed reception. Mode 2 offers an additional trade-off between transmission area size and mobile reception capabilities. The mode should be selected by taking the applied radio frequency, the scale of SFN, and the type of service reception into consideration.

TABLE 2
Technical features of systems

		Multimedia System A	Multimedia System F	Multimedia System I	Multimedia System H	Multimedia System T2	Multimedia System R
1	Multipath interference	Choice of four transmission modes, using OFDM modulation, offer flexible and appropriate protection against multipath interference in many situations	Choice of four guard intervals, choice of three Modes, and scattered pilots for reference symbol, using OFDM modulation, offer flexible and appropriate protection against multipath interference in many situations	Multipath interference is mitigated by selecting the appropriate guard interval duration (among 4) and Mode (1k, 2k, 4k or 8k)	Multipath interference is mitigated by selecting the appropriate guard interval duration (among 4) and Mode (2k or 4k) and inner interleaver mode (in-depth or native interleaving)	Possibility of choice of 6 guard interval (1/128, 1/32, 1/16, 19/256, 1/8, 19/128, 1/4), 4 OFDM modes, 7 pilot patterns (PP1-PP7), P1 symbol availability, SISO/MISO modes providing high robustness in multipath environment	Multipath interference is mitigated by selecting the appropriate modulation mode (influences on bit and cell interleaver duration) and time interleaver duration
2	Fading environments	Choice of four transmission modes, using OFDM modulation, offer flexible and appropriate protection in fading environments in many situations	Choice of three Modes, choice of time interleaving up to approximately 0.8 s and scattered pilots for reference symbol, using OFDM modulation, offer flexible and appropriate protection in fading environments in many situations	The combination of Turbo Code and flexible interleaver (up to 10 s) provides protection even in very challenging including blockage of duration comparable to the length of the interleaver		Possibility of choice of different OFDM modes, different depth of interleaving and mechanisms of interleaving (approx. 5 stages of interleaving and some virtual interleaving) allowing for robust operation in fading condition	Possibility of choice of different modulation modes, different duration of time interleaving allowing for robust operation in fading condition

TABLE 2 (continued)

		Multimedia System A	Multimedia System F	Multimedia System I	Multimedia System H	Multimedia System T2	Multimedia System R
3	Single frequency networks	Typical SFN cell size is about 70 km (DQPSK, 1/2, guard interval 256 μ s) depending the frequency and transmission power	SFN is typically supported in 8k-FFT with selectable FEC code rate and carrier modulation scheme. Long delay multipath signal caused by SFN is acceptable by long guard interval up to approximately 250 μ s	SFN cell radius is mostly dependent on the configuration (SH-A or SH-B) and selection of the guard interval duration. Typical SFN distance is 30-35 km, extendable to 100 km			Typical SFN cell size is up to 70 km depending the frequency and transmission power
4	Simultaneous transmission of different quality levels (hierarchical transmission)	T-DMB: Not applicable AT-DMB: Different quality levels can be independently set to each layer Furthermore, up to four levels of different quality transmission is possible with adjusting constellation ratio	Different quality levels can be independently set to each basic composition of segments. Furthermore, up to three levels of different quality transmission is possible with 13-segment composition, and two levels of different quality transmission are possible with 3-segment composition	Hierarchical modulation is fully supported. Furthermore, a low-latency service can be embedded into a regular service using a feature of the interleaver		Depending on selected system configuration it is possible to choose different service error protection for one or multiple physical layer pipes (PLP), each having its own specific modulation, coding and time interleaving depth, thus enabling service-specific robustness	

TABLE 2 (continued)

		Multimedia System A	Multimedia System F	Multimedia System I	Multimedia System H	Multimedia System T2	Multimedia System R
5	Spectrum efficiency (bit/s/Hz)	<p>T-DMB: From 0.375 (DQPSK, convolutional code rate 1/4) to 1.125 (DQPSK, convolutional code rate 3/4) bit/s/Hz.</p> <p>AT-DMB: From 0.5625 (BPSK over DQPSK, convolutional code rate 1/4, turbo code 1/4) to 1.5 (BPSK over DQPSK, convolutional code rate 3/4, turbo code rate 1/2) bit/s/Hz</p> <p>AT-DMB: From 0.75 (QPSK over DQPSK, convolutional code rate 1/4, turbo code rate 1/4) to 1.875 (QPSK over DQPSK, convolutional code rate 3/4, turbo code rate 1/2) bit/s/Hz</p>	<p>From 0.655 bit/s/Hz (QPSK 1/2) to 4.170 bit/s/Hz (64-QAM 7/8)</p> <p>Higher spectrum efficiency is provided by connected transmission because guard band is not required</p>	<ul style="list-style-type: none"> – With GI 1/4: From 0.2806 bit/s/Hz with QPSK 1/5 to 1.8709 bit/s/Hz with 16QAM 2/3 – With GI 1/32: From 0.3402 bit/s/Hz with QPSK 1/5 to 2.2678 bit/s/Hz with 16QAM 2/3 	<p>From 0.46 bit/s/Hz (QPSK 1/2 MPE-FEC 3/4) to 1.86 bit/s/Hz (64-QAM 2/3 MPE-FEC 3/4)</p>	<p>From 0.87 bit/s/Hz (QPSK 1/2) to 4.34 bit/s/Hz (64-QAM 3/4)</p> <p>Provided values of Spectral efficiency does not take into account loss due to signalling/ synchronization and Guard interval</p>	<p>From 0.77 bit/s/Hz (QPSK 1/2) to 3.64 bit/s/Hz (64-QAM 3/4)</p>

TABLE 2 (*end*)

		Multimedia System A	Multimedia System F	Multimedia System I	Multimedia System H	Multimedia System T2	Multimedia System R
6	Power consumption for handheld receivers	Low power consumption feature of DAB is applied Optimized narrow bandwidth allows low system clock frequency and simple FFT calculation. Supports sub-channel decoding for selected service	Narrow bandwidth and partial reception out of wideband signal enables low system clock frequency. Lower system clock in a receiver provides lower power consumption	Time slicing provides ~90% power saving compared to continuous reception in the DVB-SH receiver part	Time slicing	T2 time slicing with PLP concept	Narrow bandwidth enables low system clock frequency in a receiver that provides lower power consumption

Attachment 1 to Annex 1

Multimedia system A (T-DMB and AT-DMB)

A.1 Overview and summary of T-DMB

Terrestrial Digital Multimedia Broadcasting (T-DMB) is the enhanced system of digital System A defined in Recommendation ITU-R BS.1114, which enables multimedia service including video, audio, and interactive data for handheld receivers in a mobile environment.

For audio service it uses MPEG-4 ER-BSAC or MPEG-4 HE AAC v2 + MPEG Surround in addition to MPEG-1/MPEG-2 Audio Layer II specified in digital System A. For video service ITU-T H.264 | MPEG-4 AVC standard is used for video, MPEG-4 ER-BSAC or MPEG-4 HE AAC v2 + MPEG Surround for the associated audio, and MPEG-4 BIFS and MPEG-4 SL for interactive data. Outer channel coding of Reed-Solomon code is applied to provide stable performance of video reception.

Conceptual T-DMB architecture for video service that transmits MPEG-4 content encapsulated using “MPEG-4 over MPEG-2 TS” specification is illustrated in Fig. A1-1.

FIGURE A1-1
Conceptual T-DMB architecture for video service

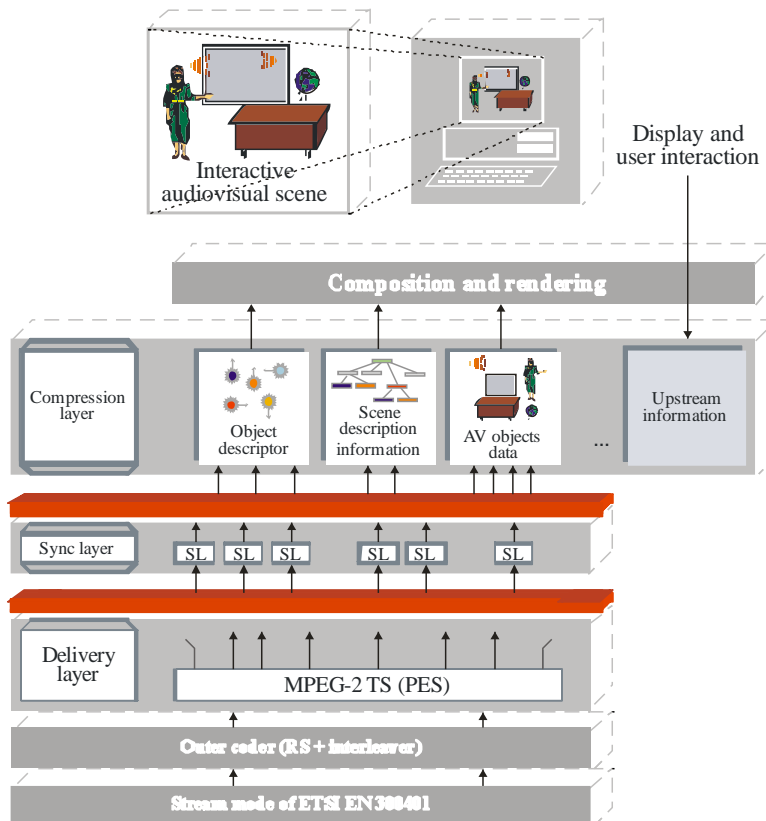

BT.2016-A1-01

Detailed mechanism on how to provide video service in a mobile environment is defined in ETSI TS 102 427 and ETSI TS 102 428 standards.

A.2 Overview and summary of AT-DMB

The second generation of T-DMB, which is called Advanced T-DMB or AT-DMB in short, increases channel capacity of T-DMB, Multimedia System A in the Recommendation ITU-R BT.1833, up to twice at maximum the T-DMB System, is operable in T-DMB networks, since it is completely backward-compatible with T-DMB. The basic parameters of AT-DMB such as channel bandwidth, number of carriers, symbol duration, guard interval duration, etc., are the same as those of T-DMB.

For improvement of channel capacity, a hierarchical modulation is applied; BPSK or QPSK symbol is mapped over DQPSK symbol. Table A1-1 shows parameters of both T-DMB and AT-DMB. AT-DMB uses both Band III and L-Band spectrum in which T-DMB networks are in operation. It guarantees backward compatibility with T-DMB. Thus, using increased channel capacity of AT-DMB system, it can provide either better quality or additional services other than the services provided by T-DMB system. Detailed specification is described in the Standard “TTAK.KO-07.0070/R2” for modulation and error protection mechanism.

TABLE A1-1

Parameters comparison between AT-DMB and T-DMB systems

Parameters	T-DMB	AT-DMB
Standard	Recommendation ITU-R BS.1114 Digital System A	Recommendation ITU-R BS.1114 Digital System A, TTAK.KO-07.0070/R2
Channel code (code rate)	Convolutional code (1/4, 3/8, 1/2, 3/4)	Convolutional code, (1/4, 3/8, 1/2, 3/4) Turbo code (1/2, 2/5, 1/3, 1/4)
Modulation method (time interleaving depth)	DQPSK (384 msec)	DQPSK (384 msec), BPSK over DQPSK (768 msec), QPSK over DQPSK (384 msec)
Constellation ratio	N/A	1.5, 2.0, 2.5, 3.0, ∞^*

* ∞ means that the hierarchical modulation is not applied.

AT-DMB can provide a scalable video service as well as all kinds of T-DMB services. The scalable video service fully guarantees backward compatibility with the video service of T-DMB. It can serve VGA quality video service to AT-DMB receivers, QVGA quality video service to T-DMB receivers. For audio of the scalable video service, it uses ISO/IEC 23003-1 for MPEG-4 ER-BSAC or MPEG-4 HE AAC v2 + MPEG Surround. For video of the scalable video service, it uses base line profile of Recommendation ITU-T H.264 | ISO/IEC 14496-10 Amendment 3 for MPEG-4 SVC.

Refer to TTAK.KO-07.0070/R2 for hierarchical modulation scheme, error correction code, etc., of AT-DMB and TTAK.KO-07.0071 for AT-DMB scalable video service.

A.3 Transmission system architecture

There are two layers in AT-DMB system: one layer is a base layer for T-DMB receivers; the other layer is an enhancement layer that provides the additional service for AT-DMB receivers only. In order to improve channel error correction capability in the enhancement layer, turbo code is applied instead of convolutional code (CC) which is used for T-DMB receivers. Five constellation ratios of 1.5, 2.0, 2.5, 3.0 and ∞ are newly introduced to adjust reception performances and coverage areas of

both AT-DMB and T-DMB services by controlling error correction capabilities in the base and the enhancement layers. Figure A1-2 shows the conceptual transmission system architecture of AT-DMB.

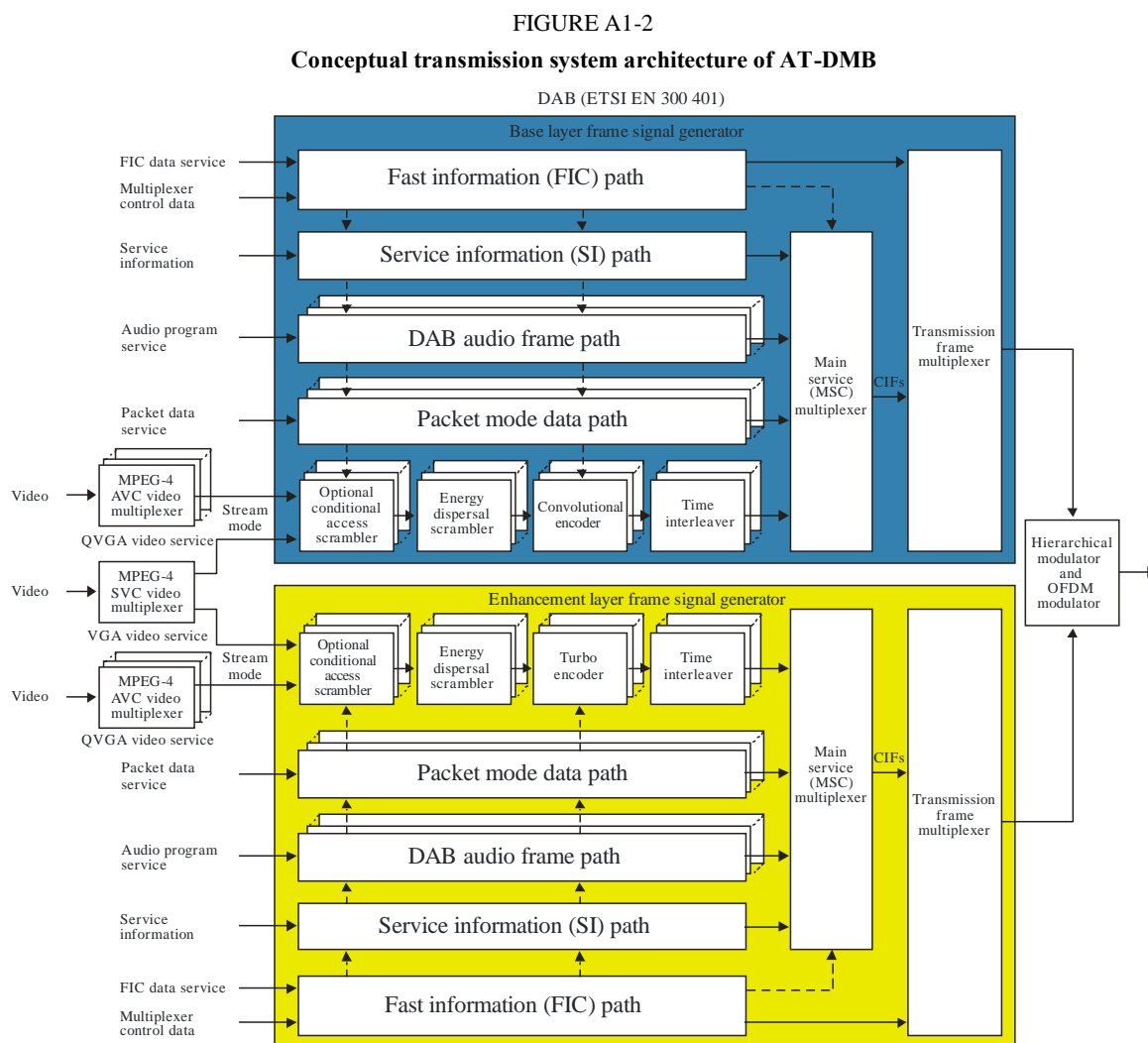

BT.2016-A1-02

Bibliography

Normative references

- [1] Recommendation ITU-R BS.1114 – *System A: System for terrestrial digital sound broadcasting to vehicular, portable and fixed receivers in the frequency range 30-3 000 MHz.*
- [2] ETSI EN 300 401 – *Radio Broadcasting Systems; Digital Audio Broadcasting (DAB) to mobile, portable and fixed receivers.*
- [3] TTA, TTA.KO-07.0070/R2 – *Specification of the Advanced Terrestrial Digital Multimedia Broadcasting (AT-DMB) to mobile, portable, and fixed receivers, 2011.*

Informative references

- [4] ETSI TR 101 497 – *Digital Audio Broadcasting (DAB); Rules of Operation for the Multimedia Object Transfer Protocol.*
- [5] ETSI TS 101 759 – *Digital Audio Broadcasting (DAB); Data Broadcasting – Transparent Data Channel (TDC).*
- [6] ETSI ES 201 735 – *Digital Audio Broadcasting (DAB); Internet Protocol (IP) Datagram Tunnelling.*
- [7] ETSI TS 101 499 – *Digital Audio Broadcasting (DAB); MOT Slide Show; User Application Specification.*
- [8] ETSI TS 101 498-1 – *Digital Audio Broadcasting (DAB); Broadcast Website; Part 1: User Application Specification.*
- [9] ETSI TS 101 498-2 – *Digital Audio Broadcasting (DAB); Broadcast Website; Part 2: Basic Profile Specification.*
- [10] ETSI EN 301 234 – *Digital Audio Broadcasting (DAB); Multimedia Object Transfer (MOT) Protocol.*
- [11] ETSI TS 102 371 – *Digital Audio Broadcasting (DAB); Transportation and Binary Encoding Specification for DAB Electronic Programme Guide (EPG).*
- [12] ETSI TS 102 818 – *Digital Audio Broadcasting (DAB); XML Specification for DAB Electronic Programme Guide (EPG).*
- [13] ETSI TS 102 427 – *Digital Audio Broadcasting (DAB); Data Broadcasting – MPEG-2 TS Streaming.*
- [14] ETSI TS 102 428 – *Digital Audio Broadcasting (DAB); DMB video service; User Application Specification.*
- [15] Report ITU-R BT.2049-3 – *Broadcasting of multimedia and data applications for mobile reception.*
- [16] TTA, TTA.KO-07.0071 – *Advanced Terrestrial Digital Multimedia Broadcasting (AT-DMB) Scalable Video Service.*

Attachment 2 to Annex 1

Multimedia System F (ISDB-T multimedia broadcasting for mobile reception)

Multimedia System F is the enhanced ISDB-T/T_{SB}-based multimedia broadcasting system called “ISDB-T multimedia broadcasting for mobile reception”. The system is based on the transmission technology of System C (also known as ISDB-T) in Recommendation ITU-R BT.1306 and Digital System F (also known as ISDB-T_{SB}) in Recommendation ITU-R BS.1114. Digital System F can be regarded as a narrow-band variation of ISDB-T. Figure A2-1 shows three basic compositions of ISDB-T multimedia broadcasting.

As featured by System C, Multimedia System F provides hierarchical transmission. This enables allocation of signals for mobile reception that requires greater robustness in the same channel as that for stationary reception. Use of “OFDM segments”, units of OFDM carriers corresponding to 1/13 of a channel, is a key technique for this. One or more segments form a segment group. The transmission parameters of the modulation scheme of OFDM carriers, the coding rates of inner error correcting code, and the length of the time interleaving can be independently specified for each segment group. A segment group is the basic unit for delivering broadcast services, hence transmission parameters of the segments are common within the group.

The centre segment of ISDB-T and ISDB-T_{SB} is a special segment that is suitable for establishing a segment group having only one segment. When only the centre segment forms a segment group, the segment can be received independently.

The number of segments of Multimedia System F can be chosen in accordance with the application and available bandwidth. The spectrum is formed by combining 1-segment, 3-segment, and/or 13-segment blocks without a guard band. Figure A2-2 shows example combinations of the segment blocks. A receiver can partially demodulate a 1-, 3- or 13-segment part so that the hardware and software resources for ISDB-T or ISDB-T_{SB} receivers can be used to make receivers for the ISDB-T multimedia broadcasting for mobile reception.

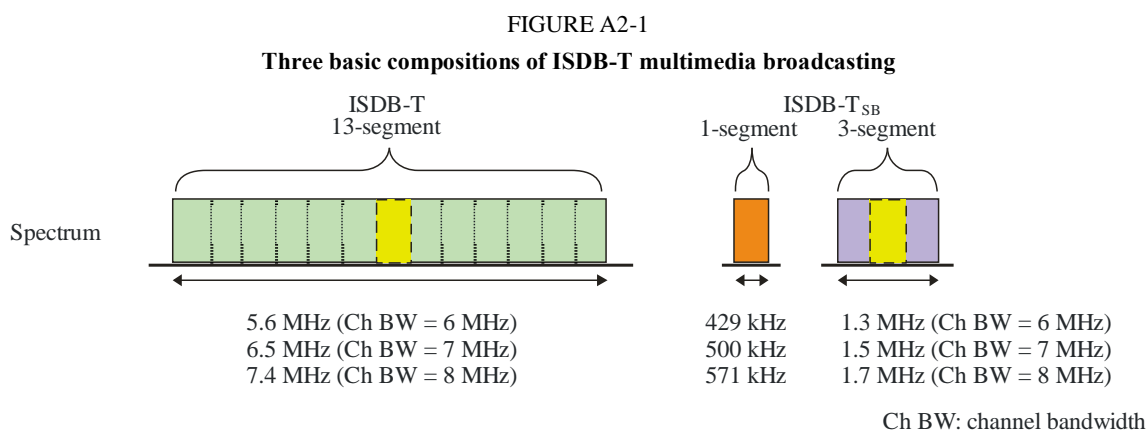

BT.2016-A2-01

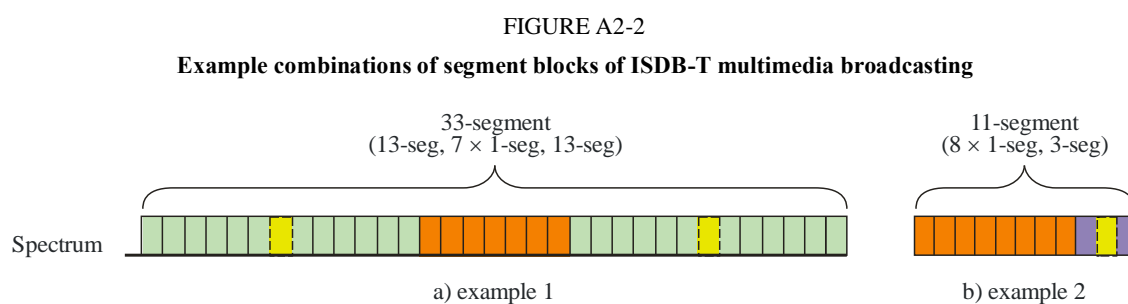

BT.2016-A2-02

Bibliography

- [1] Recommendation ITU-R BS.1114 – *Systems for terrestrial digital sound broadcasting to vehicular, portable and fixed receivers in the frequency range 30-3 000 MHz.*
- [2] Recommendation ITU-R BT.1306 – *Error-correction, data framing, modulation and emission methods for digital terrestrial television broadcasting.*
- [3] ARIB STD-B46 – *Transmission system for terrestrial mobile multimedia broadcasting based on connected segments transmission, Association of Radio Industries and Businesses.*

Attachment 3 to Annex 1

Multimedia system I (DVB-SH)

Multimedia system “I” is an end-to-end broadcast system for delivery of any type of digital content and services using IP-based mechanisms optimized for devices with limitations on computational resources and battery. It consists of a unidirectional broadcast path that may be combined with a bidirectional mobile cellular (2G/3G/4G) interactivity path. The terrestrial component of multimedia system “I” (CGC) may be combined or integrated with a satellite component (SC) as illustrated in Fig. A3-1. The system specifications can be divided into the following categories:

- General end-to-end system descriptions.
- DVB-SH radio interfaces.
- IP-based services delivery over DVB-SH service layer.
- IP-based services delivery codecs and content formats.

DVB-SH is an enhancement of DVB-H, itself based on the widely accepted DVB-T digital broadcast standard for mobile broadcast reception. The umbrella specification for DVB-SH is ETSI TS 102 585.

DVB-SH systems use the forward error correction (FEC) scheme 3GPP2 Turbo code over 12 kbit/s blocks. In addition, DVB-SH systems use a highly flexible channel interleaver that offers time diversity from about one hundred milliseconds to several seconds depending on the targeted service level and corresponding capabilities (essentially memory size) of terminal class. The radio interface specification for DVB-SH is ETSI EN 302 583.

FIGURE A3-1
DVB SH-B architecture – Transmitter side

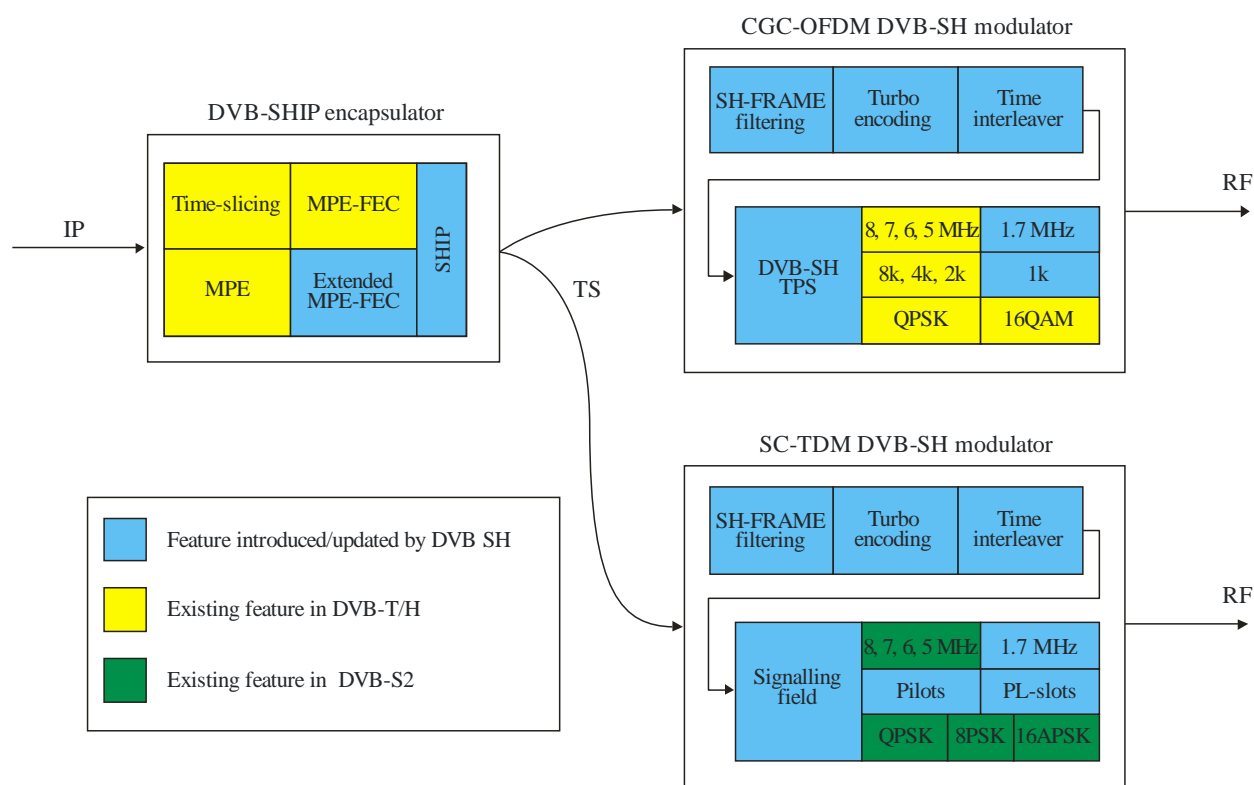

BT.2016-A3-01

DVB-SH system signalling specifications in ETSI TS 102 470-2 defines the exact use of PSI/SI information in case of an IP-based services delivery.

For video services H.264/AVC and for audio HE AAC v2 codecs and respective RTP payload formats are used. Several types of data are supported including e.g. binary data, text and still images.

RTP is the IETF protocol used for streaming services. Delivery of any kind of files in an IP-based services delivery system is supported by the IETF FLUTE protocol.

An electronic service guide has been specified to allow fast discovery and a selection of services for the end user.

Versatile service purchase and protection mechanisms have been defined for broadcast-only and interaction-capable handheld receivers.

Mechanisms have been defined for mobility over DVB-SH networks and between DVB-H and DVB-SH networks.

DVB-SH Implementation Guidelines including numerous results from laboratory and field trials are provided in ETSI TS 102 584.

Bibliography

General end-to-end system description

- ETSI TS 102 585 – *Digital video broadcasting (DVB); System specifications for satellite services to handheld devices (SH) below 3 GHz.*

Radio interface

- ETSI EN 302 583 – *Digital video broadcasting (DVB); Framing structure, channel coding and modulation for satellite services to handheld devices (SH) below 3 GHz.*

Link layer

- ETSI EN 301 192 – *Digital video broadcasting (DVB); DVB specification for data broadcasting.*
- ETSI TS 102 772 – *Digital video broadcasting (DVB); Specification of multi-protocol encapsulation – inter-burst forward error correction (MPE-IFEC).*

System level signalling

- ETSI TS 102 470-2 – *Digital video broadcasting (DVB); IP Datacast over DVB-SH: Programme specific information (PSI)/(Service Information (SI)).*

IP Datacast service layer

The electronic service Guide is specified in:

- ETSI TS 102 471 – *Digital video broadcasting (DVB); IP Datacast over DVB-H: Electronic service Guide (ESG).*
- ETSI TS 102 592-2 – *IP Datacast over DVB-SH: Electronic service Guide (ESG) implementation Guidelines.*

The content delivery protocols are specified in:

- ETSI TS 102 472 – *Digital video broadcasting (DVB); IP Datacast over DVB-H: Content delivery protocols.*
- ETSI TS 102 591-2 – *Digital video broadcasting (DVB); IP Datacast: Content delivery protocols implementation Guidelines; Part 2: IP Datacast over DVB-SH.*

Service purchase and protection mechanisms are specified in:

- ETSI TS 102 474 – *Digital video broadcasting (DVB); IP Datacast over DVB-H: Service purchase and protection.*

Mechanisms for mobility are specified in:

- ETSI TS 102 611-2 – *IP Datacast over DVB-SH: Implementation Guidelines for mobility.*

IP Datacast codecs and formats

- ETSI TS 102 005 – *Digital video broadcasting (DVB); Specification for the use of video and audio coding in DVB services delivered directly over IP.*

Guidelines for deployment of DVB-SH

- ETSI TS 102 584 – *Digital video broadcasting (DVB); DVB-SH Implementation Guidelines.*

OMA BCAST 1.1 specifications

OMA BCAST is a set of service layer specifications, applicable to various broadcast bearers, including the DVB-SH broadcast bearers.

- “BCAST Distribution system adaptation – IPDC over DVB-SH”, open mobile alliance, Version 1.1.

Attachment 4 to Annex 1

Multimedia System H (DVB-H)

DVB-H is a broadcast transmission system for multimedia broadcasting by datagrams. These datagrams may be IP or other datagrams and may contain data that pertain to multimedia services, file downloading services, or to other services not mentioned here.

The objective of DVB-H is to provide efficient means for carrying these multimedia data over digital terrestrial broadcasting networks to handheld terminals. The main characteristics with regard to efficiency are considered to be constraints on power supply and varying transmission conditions due to mobility.

DVB-H basic specifications (Recommendations ITU-R BT.1306, ITU-R BT.1833, and Report ITU-R BT.2049, ETSI EN 302 304) provide:

- the physical layer;
- the link layer;
- the service information.

Recommendations about the synchronization of SFNs in DVB-H are also provided.

Further information and recommendations about how to use and select the appropriate parameters of DVB-H are provided in documents that are listed in the bibliography.

DVB-H makes use of the following technology elements for the link layer and the physical layer:

- Link layer:
 - i) time-slicing in order to reduce the average power consumption of the terminal and enabling smooth and seamless frequency handover;
 - ii) forward error correction for multiprotocol encapsulated data (MPE-FEC) for an improvement in C/N-performance and Doppler performance in mobile channels, also improving tolerance to impulse interference.
- Physical layer:

DVB-T (see EN 300 744) with the following technical elements specifically targeting DVB-H use:

 - i) DVB-H signalling in the TPS-bits to enhance and speed up service discovery. Cell identifier is also carried on TPS-bits to support quicker signal scan and frequency handover on mobile receivers;
 - ii) 4K-mode for trading off mobility and SFN cell size, allowing single antenna reception in medium SFNs at very high speed, adding thus flexibility in the network design;
 - iii) in-depth symbol interleaver for the 2K and 4K-modes for further improving their robustness in mobile environment and impulse noise conditions.

It should be mentioned that both time-slicing and MPE-FEC technology elements, as they are implemented on the link layer, do not touch the DVB-T physical layer in any way. It is also important to notice that the payload of DVB-H are IP-datagrams or other network layer datagrams encapsulated into MPE-sections.

The conceptual structure of a DVB-H receiver is depicted in Fig. A4-1. It includes a DVB-H demodulator and a DVB-H terminal. The DVB-H demodulator includes a DVB-T demodulator, a time-slicing module and a MPE-FEC module.

- The DVB-T demodulator recovers the MPEG-2 Transport Stream packets from the received DVB-T (see EN 300 744) RF signal. It offers three transmission modes 8K, 4K and 2K with the corresponding Transmitter Parameter Signalling (TPS). Note that the 4K mode, the in-depth interleavers and the DVB-H signalling have been defined while elaborating the DVB-H standard.
- The time-slicing module, provided by DVB-H, aims to save receiver power consumption while enabling to perform smooth and seamless frequency handover.
- The MPE-FEC module, provided by DVB-H, offers over the physical layer transmission, a complementary forward error correction allowing the receiver to cope with particularly difficult receiving situations.

FIGURE A4-1
Conceptual structure of a DVB-H receiver

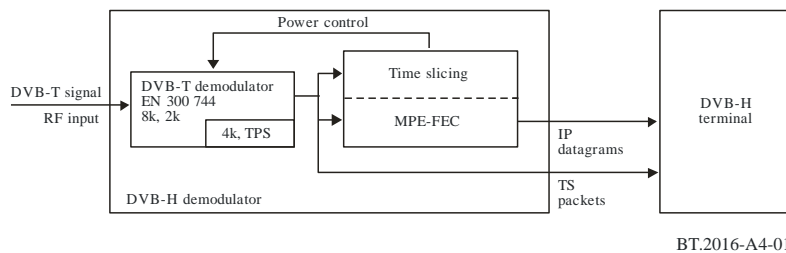

An example of using DVB-H for transmission of IP-services is given in Fig. A4-2. In this example, both traditional MPEG-2 services and time-sliced “DVB-H services” are carried over the same multiplex. The handheld terminal decodes/uses IP-services only.

FIGURE A4-2
A conceptual description of using a DVB-H system (sharing a MUX with MPEG2 services)

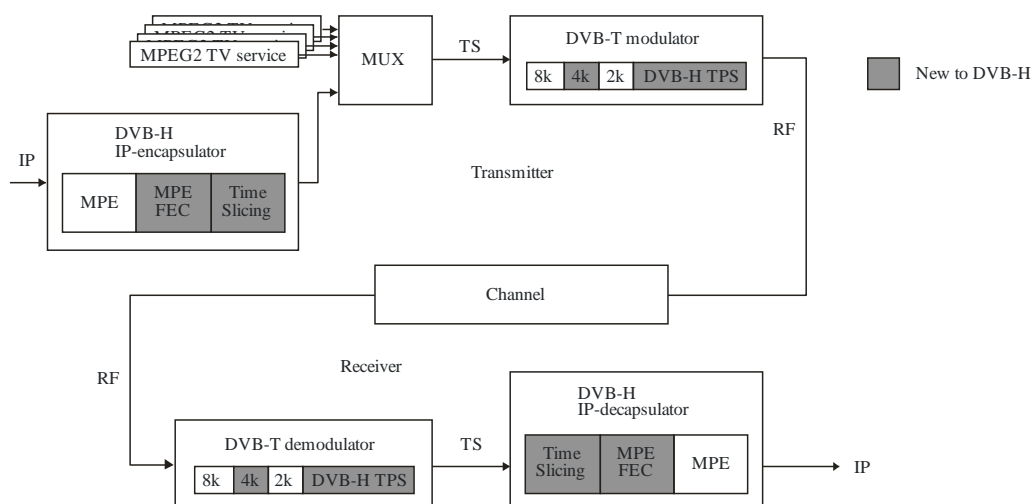

Time-slicing

The objective of time-slicing is to reduce the average power consumption of the terminal and enable smooth and seamless service handover. Time-slicing consists of sending data in bursts using significantly higher instantaneous bit rate compared to the bit rate required if the data were transmitted using traditional streaming mechanisms.

To indicate to the receiver when to expect the next burst, the time (Δt) to the beginning of the next burst is indicated within the burst. Between the bursts, data of the elementary stream is not transmitted, allowing other elementary streams to use the bandwidth otherwise allocated. Time-slicing enables a receiver to stay active only a fraction of the time, while receiving bursts of a requested service. Note that the transmitter is constantly on (i.e. the transmission of the transport stream is not interrupted).

Time-slicing also supports the possibility to use the receiver to monitor neighbouring cells during the off-times (between bursts). By accomplishing the switching of the reception from one transport stream to another during an off period it is possible to accomplish a quasi-optimum handover decision as well as seamless service handover.

MPE-FEC

The objective of the MPE-FEC is to improve the C/N- and Doppler performance in mobile channels and to improve the tolerance to impulse interference.

This is accomplished through the introduction of an additional level of error correction at the MPE layer. By adding parity information calculated from the datagrams and sending this parity data in separate MPE-FEC sections, error-free datagrams can be output after MPE-FEC decoding despite a very bad reception condition. The use of MPE-FEC is optional.

With MPE-FEC a flexible amount of the transmission capacity is allocated to parity overhead. For a given set of transmission parameters providing 25% of parity overhead, the MPE-FEC may require about the same C/N as a receiver with antenna diversity.

The MPE-FEC overhead can be fully compensated by choosing a slightly weaker transmission code rate, while still providing far better performance than DVB-T (without MPE-FEC) for the same throughput. This MPE-FEC scheme should allow high-speed single antenna DVB-T reception using 8K/16-QAM or even 8K/64-QAM signals. In addition MPE-FEC provides good immunity to impulse interference.

The MPE-FEC, as standardized, works in such a way that MPE-FEC ignorant (but MPE capable) receivers will be able to receive the data stream in a fully backwards-compatible way, provided it does not reject the used stream_type.

4K mode and in-depth interleavers

The objective of the 4K mode is to improve network planning flexibility by trading off mobility and SFN size. To further improve robustness of the DVB-T 2K and 4K modes in a mobile environment and impulse noise reception conditions, an in-depth symbol interleaver is also standardized.

The additional 4K transmission mode is a scaled set of the parameters defined for the 2K and 8K transmission modes. It aims to offer an additional trade-off between Single Frequency Network (SFN) cell size and mobile reception performance, providing an additional degree of flexibility for network planning.

Terms of the trade-off can be expressed as follows:

- The DVB-T 8K mode can be used both for single transmitter operation and for small, medium and large SFNs. It provides a Doppler tolerance allowing high speed reception.
- The DVB-T 4K mode can be used both for single transmitter operation and for small and medium SFNs. It provides a Doppler tolerance allowing very high speed reception.
- The DVB-T 2K mode is suitable for single transmitter operation and for small SFNs with limited transmitter distances. It provides a Doppler tolerance allowing extremely high speed reception.

For 2K and 4K modes the in-depth interleavers increase the flexibility of the symbol interleaving, by decoupling the choice of the inner interleaver from the transmission mode used. This flexibility allows a 2K or 4K signal to take benefit of the memory of the 8K symbol interleaver to effectively quadruple (for 2K) or double (for 4K) the symbol interleaver depth to improve reception in fading channels. This provides also an extra level of protection against short noise impulses caused by, e.g. ignition interference and interference from various electrical appliances.

4K and in-depth interleavers affect the physical layer, however their implementations do not imply large increase in equipment (i.e. logic gates and memory) over the version 1.4.1 of DVB-T standard for either transmitters or receivers. A typical mobile demodulator already incorporates enough RAM and logic for the management of 8K signals, which exceed that required for 4K operation.

The emitted spectrum of the 4K mode is similar to the 2K and 8K modes thus no changes in transmitter filters are envisaged.

DVB-H signalling

The objective of the DVB-H signalling is to provide a robust and easy-to-access signalling to the DVB-H receivers, thus enhancing and speeding up service discovery.

TPS is a very robust signalling channel allowing TPS-lock in a demodulator with very low C/N-values. TPS provides also a faster way to access signalling than demodulating and decoding the Service Information (SI) or the MPE-section header.

The DVB-H system uses two TPS bits to indicate the presence of time-slicing and optional MPE-FEC. Besides these, the signalling of the 4K mode and the use of in-depth symbol interleavers are also standardized.

Bibliography

- [1] ETSI EN 300 744 – *Digital Video Broadcasting (DVB); Framing structure, channel coding and modulation for digital terrestrial television (DVB-T)*.
- [2] ETSI EN 300 468 – *Digital Video Broadcasting (DVB); Specification for Service Information (SI) in DVB systems (DVB-SI)*.
- [3] ETSI EN 301 192 – *Digital Video Broadcasting (DVB); DVB specification for data broadcasting. (DVB-DATA)*.
- [4] ETSI TS 101 191 – *Digital Video Broadcasting (DVB); DVB mega-frame for Single Frequency Network (SFN) synchronization*.
- [5] ETSI TS 102 468 – *Digital Video Broadcasting (DVB); IP Datacast over DVB-H: Set of Specifications for Phase 1*.
- [6] ETSI TR 102 473 – *Digital Video Broadcasting (DVB); IP Datacast over DVB-H: Use Cases and Services*.
- [7] ETSI TR 102 469 – *Digital Video Broadcasting (DVB); IP Datacast over DVB-H: Architecture*.
- [8] ETSI TS 102 470-1 – *Digital Video Broadcasting (DVB); IP Datacast over DVB-H: Programme Specific Information (PSI)/(Service Information (SI))*.
- [9] ETSI TS 102 471-1 – *Digital Video Broadcasting (DVB); IP Datacast over DVB-H: Electronic Service Guide (ESG)*.
- [10] ETSI TS 102 472 – *Digital Video Broadcasting (DVB); IP Datacast over DVB-H: Content Delivery Protocols*.
- [11] ETSI TS 102 474 – *Digital Video Broadcasting (DVB); IP Datacast over DVB-H: Service Purchase and Protection*.

- [12] ETSI TS 102 005 – *Digital Video Broadcasting (DVB); Specification for the use of video and audio coding in DVB services delivered directly over IP.*
- [13] ETSI TR 102 377 – *Digital Video Broadcasting (DVB); DVB-H Implementation guidelines.*
- [14] ETSI TR 102 401 – *Digital Video Broadcasting (DVB); Transmission to handheld terminals (DVB-H); Validation task force report.*

Attachment 5 to Annex 1

Multimedia system T2 (T2 Lite profile of DVB-T2 system)

Reference [3] defines the parameters of T2-Lite profile (of DVB-T2 system) used for handheld reception of multimedia broadcasting signals. This profile is intended to allow simpler receiver implementations for very low capacity applications such as mobile broadcasting, although it may also be received by conventional stationary receivers. T2-Lite is a limited sub-set of the modes of the T2 specification, and by avoiding modes which require the most complexity and memory, allows much more efficient receiver designs to be used. The limitations imposed for T2-Lite are described in [3]. A T2-Lite signal is identified by appropriate signalling.

The T2-Lite signal may be multiplexed together with a T2-base signal (and/or with other signals), with each signal being transmitted in the other's Future Extension Frame (FEF) parts. So, for example, a complete RF signal may be formed by combining a 32K FFT T2-base profile signal carrying HDTV services for fixed receivers using 256-QAM modulation, together with a T2-Lite profile signal using an 8K FFT and QPSK modulation to serve mobile receivers from the same network.

Bibliography

- [1] Recommendation ITU-R BT.1877 – *Error-correction, data framing, modulation and emission methods for second generation of digital terrestrial television broadcasting systems.*
- [2] Report ITU-R BT.2254 – *Frequency and network planning aspects of DVB-T2.*
- [3] ETSI EN 302 755 – *Digital Video Broadcasting (DVB); Frame structure channel coding and modulation for a second generation digital terrestrial television broadcasting system (DVB-T2).*
- [4] ETSI TR 102 831 – *Digital Video Broadcasting (DVB); Implementation guidelines for a second generation digital terrestrial television broadcasting system (DVB-T2).*

Attachment 6 to Annex 1

Multimedia system R (RAVIS)

Digital terrestrial multimedia and sound broadcasting system RAVIS (Real-time Audio-Visual Information System) is designed for use in the terrestrial VHF broadcasting bands I and II. The frequency range used by RAVIS enables to deploy local broadcasting. At the same time, the coverage radius of the transmitter is large enough to provide reception in remote places.

The RAVIS system is designed for high quality multi-programme sound, video with several sound accompaniment channels and other data (both related and unrelated to sound and video programmes) broadcasting services. These services should be provided in various conditions, including driving in dense city environment, in woody and mountainous terrain, in water areas; i.e. a reliable reception must be provided in motion, in the absence of direct line of sight of the transmitter antennas and multipath signal propagation.

The RAVIS system allows various levels of QAM modulation and various rates of channel coding in the main service channel, which are used to achieve an optimal balance between bitrate and reliability (interference protection).

The system provides three logical data transmission channels. The main service channel (MSC) is designed for video and audio data transmission. Maximum bit rate in this logical channel is about 900 kbit/s. Low bit-rate channel (LBC) is designed for transmission of information with increased reliability, bit rate is about 12 kbit/s. Reliable data channel (RDC) is designed for auxiliary data with high reliability, bit rate is about 5 kbit/s. The LBC and RDC provide higher interference protection and consequently larger coverage and higher stability of reception compared to MSC. These reliable channels may be used, for example, for emergency alerting, etc.

Bibliography

- [1] Recommendation ITU-R BS.1114 – *System for terrestrial digital sound broadcasting to vehicular, portable and fixed receivers in the frequency range 30-3 000 MHz.*
 - [2] Report ITU-R BT.2049 – *Broadcasting of multimedia and data applications for mobile reception.*
 - [3] Report ITU-R BS.2214 – *Planning parameters for terrestrial digital sound broadcasting systems in VHF bands.*
 - [4] ITU-R Handbook – *Handbook on Digital Terrestrial Television Broadcasting Networks and Systems Implementation (2016).*
 - [5] GOST R 54309–2011 – *Real-time audiovisual information system (RAVIS). The formation processes of frame structure, channel coding and modulation for the digital terrestrial narrowband radio broadcasting system in VHF band. Technical specifications. (In Russian)*
-