

International Telecommunication Union

ITU-R
Radiocommunication Sector of ITU

Recommendation ITU-R BT.1833-1
(03/2011)

**Broadcasting of multimedia and data
applications for mobile reception by
handheld receivers**

BT Series
Broadcasting service
(television)



Foreword

The role of the Radiocommunication Sector is to ensure the rational, equitable, efficient and economical use of the radio-frequency spectrum by all radiocommunication services, including satellite services, and carry out studies without limit of frequency range on the basis of which Recommendations are adopted.

The regulatory and policy functions of the Radiocommunication Sector are performed by World and Regional Radiocommunication Conferences and Radiocommunication Assemblies supported by Study Groups.

Policy on Intellectual Property Right (IPR)

ITU-R policy on IPR is described in the Common Patent Policy for ITU-T/ITU-R/ISO/IEC referenced in Annex 1 of Resolution ITU-R 1. Forms to be used for the submission of patent statements and licensing declarations by patent holders are available from <http://www.itu.int/ITU-R/go/patents/en> where the Guidelines for Implementation of the Common Patent Policy for ITU-T/ITU-R/ISO/IEC and the ITU-R patent information database can also be found.

Series of ITU-R Recommendations

(Also available online at <http://www.itu.int/publ/R-REC/en>)

Series	Title
BO	Satellite delivery
BR	Recording for production, archival and play-out; film for television
BS	Broadcasting service (sound)
BT	Broadcasting service (television)
F	Fixed service
M	Mobile, radiodetermination, amateur and related satellite services
P	Radiowave propagation
RA	Radio astronomy
RS	Remote sensing systems
S	Fixed-satellite service
SA	Space applications and meteorology
SF	Frequency sharing and coordination between fixed-satellite and fixed service systems
SM	Spectrum management
SNG	Satellite news gathering
TF	Time signals and frequency standards emissions
V	Vocabulary and related subjects

Note: This ITU-R Recommendation was approved in English under the procedure detailed in Resolution ITU-R 1.

Electronic Publication
Geneva, 2011

© ITU 2011

All rights reserved. No part of this publication may be reproduced, by any means whatsoever, without written permission of ITU.

RECOMMENDATION ITU-R BT.1833-1^{*,**}**Broadcasting of multimedia and data applications for
mobile reception by handheld receivers**

(Question ITU-R 45/6)

(2007-2011)

Scope

This Recommendation provides an answer to the specific objectives of Question ITU-R 45/6 in order to guide administrations, as well as the broadcasting and radiocommunication industries, in the development of mobile broadcasting multimedia and data solutions. The scope of this Recommendation deals with the special aspects of end user requirements for handheld receivers.

The ITU Radiocommunication Assembly,

considering

- a) that digital television and sound broadcasting systems have been implemented in many countries and will be introduced in many more in the coming years;
- b) that multimedia and data broadcasting services have been introduced, or are planned to be introduced, using the inherent capability of digital broadcasting systems;
- c) that mobile telecommunication systems with advanced information technologies are planned to be implemented in some countries, and will be implemented in other countries in the near future;
- d) that the characteristics of mobile reception are quite different from the fixed reception cases;
- e) that digital broadcasting services are expected to be offered in a variety of reception environments including those aimed at indoor, portable, handheld and vehicular receivers;
- f) that the display sizes and receiver capabilities of handheld, portable and vehicular receivers are different from those of fixed receivers;
- g) that a special case of mobile reception by handheld receivers requires specific technical characteristics;
- h) the need for interoperability between the mobile telecommunication services and interactive digital broadcasting services;
- j) the need for technical methods to ensure cyber security and conditional access solutions,

noting

- a) that there are telecommunication systems not explicitly dedicated to broadcasting services, such as Multimedia Broadcast/Multicast Services (MBMS) as shown in Appendix 1 that fulfil the requirements for interoperability between mobile telecommunication services and interactive digital broadcasting services;

* Note by the BR Secretariat – This Recommendation was amended editorially in April 2008.

** This Recommendation should be brought to the attention of the Radiocommunication Study Group 4.

b) that there are multimedia systems combining satellite component (dedicated or not explicitly dedicated to broadcasting) and dedicated terrestrial broadcasting components integrated within national frequency plans as shown in Appendix 3 that fulfil the requirements for wide coverage with good quality of service,

recommends

1 that administrations wishing to implement broadcasting of multimedia and data applications for mobile reception by handheld receivers are invited to consider the end user requirements as stated in Annex 1 for the evaluation and assessment of the respective system characteristics of multimedia systems as described in Tables 1, 2 and 3 for the type of applications that meet these end user requirements;

2 that Multimedia Systems listed in Annex 1 and further described in Annexes 2 through 5, may be applied for broadcasting of multimedia and data applications for mobile reception by handheld receivers.

NOTE 1 – Appendices 1, 2 and 3, attached to this Recommendation, are for information.

Annex 1

1 Introduction

The end user experience and the related applications for handheld reception are different from those already available, for portable and vehicular reception. In addition, the physical limitations of handheld receivers imply specific system characteristics to meet the end user requirements.

Therefore the scope of this Recommendation on broadcast multimedia and data applications for mobile reception is in particular dealing with the special aspects of the operation of handheld devices.

1.1 Handheld receivers

Handheld receivers are battery operated devices which have significant physical limitations inherent in their dimensions (small antenna, screen sizes, etc.), screen resolution, computing power, battery capacity, etc.

1.2 Portable receivers

Portable receivers are devices which are less power-constrained and therefore might offer higher computing power. As an example, this might result in the offering of higher picture resolution applications than possible with handheld receivers.

1.3 Vehicular receivers

Vehicular receivers do not have the same physical and power-related limitations as handheld receivers have. However, the speed at which vehicular receivers may operate, on average, may be much higher. Vehicular receivers might be connected to vehicular mounted external antennas.

2 Abbreviations

3GPP	3 rd Generation Partnership Project No. 1
AAC	Advanced audio coding
ALC	Asynchronous layered coding
AMR NB/WB	Adaptive multi rate narrow band/wide band
AT-DMB	Advanced terrestrial digital multimedia broadcasting
ATSC	Advanced Television Systems Committee
AVC	Advanced video coding
ARIB	Association of Radio Industries and Businesses (Japan)
BCAST	OMA mobile broadcast services
BER	Bit error rate
BIFS	Binary format for scene description
BMP	Bit map
BM-SC	Broadcast multicast service centre
BSS (sound)	Broadcasting-satellite service for sound
CDM	Code-division multiplex
CDMA	Code-division multiple access
CGC	Complementary ground component
CIF	Common interchange format
<i>C/N</i>	Carrier to noise ratio
CLUT	Colour look-up table
CRC	Cyclic redundancy check
DAB	Digital audio broadcasting
DQPSK	Differential QPSK
DSB	Digital sound broadcasting
DVB-H	Digital video broadcasting – handheld
DVB-SH	Digital video broadcasting – Satellite services to handheld devices
DVB-T	Digital video broadcasting – terrestrial
ECMA	ECMA International (former European Computer Manufacturers Association)
ER-BSAC	Error resilience – bit sliced arithmetic coding
ES	Elementary stream
ESG	Electronic Service Guide
ETSI	European Telecommunications Standards Institute
ETSI EN	ETSI European Norm
ETSI ES	ETSI Standard
ETSI TS	ETSI Technical Specification

FCC	Federal Communications Commission
FEC	Forward error correction
FLO	Forward link only
FLUTE	File delivery over unidirectional transport
GERAN	GSM Enhanced Radio Access Network
GGSN	Serving GPRS Support Node
GIF	Graphics interchange format
GSM	Global system for mobile communications
GTP	General Packet Radio Service (GPRS) Tunnelling Protocol
HE-AAC	High efficiency advanced audio coding
HLR	Home location register
JPEG	Joint Photographic Experts Group
IEC	International Electrotechnical Commission
IETF	Internet Engineering Task Force
IMT-2000	International mobile telecommunications 2000
IOD	Initial object descriptor
IP	Internet Protocol
IPDC	Internet Protocol Data Cast
IPTV	Internet Protocol Television
ISDB-T	Terrestrial integrated services digital broadcasting
ISO	International Organization for Standardization
LOC	Local Operation Centre
MBMS	Multimedia broadcast/multicast services
MCCH	MBMS point-to-multipoint control channel
MICH	MBMS notification indicator channel
MPE	Multi Protocol Encapsulation
MPEG	Motion Picture Experts Group
MSCH	MBMS point-to-multipoint scheduling channel
MTCH	MBMS point-to-multipoint traffic channel
NOC	National Operation Centre
OD	Object descriptor
OFDM	Orthogonal frequency-division multiplexing
OIS	Overhead Information Symbols
OMA	Open mobile alliance
OSI	Open system interconnect model
PC	Personal computer

PDA	Personal digital assistant
PDC	Packet data convergence protocol
PES	Packetized elementary stream
PHY	Physical layer
PLMN	Public land mobile network
PNG	Portable networks graphics
PSI	Programme Specific Information
QAM	Quadrature amplitude modulation
QCIF	Quarter CIF
QoS	Quality of service
QPSK	Quadrature phase shift keying
QVGA	Quarter video graphics array
RF	Radio frequency
RS	Reed Solomon
RTP	Real time protocol
S-DMB	Satellite-digital multimedia broadcasting
SFN	Single frequency network
SI	Service information
SL	Sync Layer
SNR	Signal-to-noise ratio
SP-MIDI	Scalable polyphony MIDI
SQVGA	Sub quarter video graphics array
SGSN	Serving GPRS support node
SVC	Scalable video coding
SVG	Scalable vector graphics
T-DAB	Terrestrial digital audio broadcasting
TDM	Time division multiplexing
T-DMB	Terrestrial-digital multimedia broadcasting
TS	Transport Stream
TTA	Telecommunications Technology Association
TTI	Transmission time interval
UE	User equipment
UMTS	Universal Mobile Telecommunications System
UTRAN	UMTS Terrestrial Radio Access Network
VC-1	SMPTE 421M-2006 Video Codec Standard
WDF	Wide DMB Format

3 User requirements

Some user requirements for mobile reception differ from those for fixed reception. For mobile reception of broadcast multimedia and data by handheld receivers, specific requirements arise because of the differences in the usage of the receiving devices. The following requirements should be considered when implementing broadcast multimedia and data applications for mobile reception to handheld devices:

- delivery of high-quality multimedia content¹ including video, audio and/or data services;
- flexible configuration of a large variety of services (audio/video, ancillary and auxiliary data);
- access to content and services may be controlled via conditional access/service access protocols and other content protection mechanisms;
- seamless service access to content and services across networks;
- support for fast discovery and selection of content and services characterized for example, by channel acquisition time, service switching time², scheduled content delivery mechanisms, etc.;
- support for efficient mechanisms to minimize power consumption and physical size of the handheld receivers;
- support for stable and reliable service coverage for handheld receivers in various reception environments;
- support for interactivity, e.g., interactive content and applications, and/or interaction channel capabilities on handheld receivers, etc.;
- support for efficient and reliable delivery (transport) mechanisms of services; and
- technical aspects enabling interoperability of the services between broadcast and telecommunication networks, for example, content format, audio/video codecs, encapsulation methods, etc.

Additional informative user requirements:

- support for stable and reliable reception and provision of quality of service comparable to fixed reception in the mobile environment, where multipath-reflections and Doppler-shifts introduce unrecoverable errors in the broadcast data stream. Such requirements are further addressed in Appendix 2 as an informative reference.

Tables 1 to 3 list system characteristics and the technical performance of multimedia broadcasting systems for mobile reception in response to the user requirements above.

¹ The term “content” in this Recommendation means programme material and related information of any variety.

² The service switching time is the time between the user selection of a new real-time streaming service and the initial display of this delivered service to the end user.

In Tables 1 to 3, the following systems are described:

- Multimedia System “A” is based on Terrestrial Digital Multimedia Broadcasting (T-DMB, Recommendation ITU-R BS.1114 System A, ETSI TS [102 427](#) and [102 428](#)) and Advanced Terrestrial Digital Multimedia Broadcasting (AT-DMB, TTA.KO-07.0070/R1, TTA.KO-07.0071);
- Multimedia System “B” is based on ATSC Mobile DTV Standard (A/153) that is an enhancement of the ATSC system (Recommendation ITU-R BT. 1306 System A);
- Multimedia System “C” is based on Integrated Services Digital Broadcasting-Terrestrial (ISDB-T one segment);
- Multimedia System “E” is based on digital System E of Recommendation ITU-R BO.1130 for satellite component and Recommendation ITU-R BS.1547 for terrestrial component;
- Multimedia System “F” is based on Integrated Services Digital Broadcasting-Terrestrial (ISDB-T) multimedia broadcasting for mobile reception;
- Multimedia System “H” is based on Digital Video Broadcasting-Handheld (DVB-H, ETSI EN 302 304 and TR 102 377);
- Multimedia System “I” is based on Digital Video Broadcasting Satellite to Handheld devices (DVB-SH ETSI EN 302 583 and TS 102 584);
- Multimedia System “M” is based on Forward Link Only Air Interface Specification for Terrestrial Mobile Multimedia Multicast (TIA-1099).

TABLE 1

System characteristics of multimedia broadcasting for mobile reception by handheld receivers

System	System characteristics description
Multimedia System "A"	This system, also known as terrestrial digital multimedia broadcasting (T-DMB) system, is an enhancement of T-DAB system to provide multimedia services including video, audio, and interactive data services for handheld receivers in a mobile environment. Multimedia System "A" uses T-DAB networks and is completely backward compatible with T-DAB system for audio services. AT-DMB system is an enhancement of T-DMB system to increase channel capacity of T-DMB and is completely backward compatible with T-DMB system.
Multimedia System "B"	This system, also known as ATSC Mobile DTV, is an enhancement of the ATSC system to provide multimedia services including video, audio, and interactive data service delivery to small (power efficient) receivers, for fixed, handheld and vehicular environments. Multimedia System "B" uses IP-based mechanism with control of time synchronized delivery via buffer modelling for an end-to-end broadcast system including enablement of a return path to facilitate delivery of any type of digital content and service.
Multimedia System "C"	The stream signal of this system can be multiplexed with the signal for the stationary reception that coexists within a single stream. And rich content format such as script programme support provides good interactivity on a small device.
Multimedia System "E"	Target receivers are typically handheld type with a 3.5 inch wide display for QVGA video and data broadcasting in addition to high quality audio. Satellite section covers nationwide and gap-fillers augment shadow areas from the satellite path. Suitable broadcasting system is digital System E of Recommendation ITU-R BO.1130.
Multimedia System "F"	This system is designed for real-time and non-real-time broadcasting of video, sound, and multimedia content for mobile and handheld receivers based on the common technology of multimedia System C (ISDB-T). High quality video, audio, and multimedia data services can be configured flexibly. In addition, support of a script interpreter for rich content format provides flexibility for the content and service.
Multimedia System "H"	An end-to-end broadcast system for delivery of any type of digital content and services using IP-based mechanisms, such as those included in the IP Datacast (IPDC) or OMA BCAST specifications. It is based on DVB-H, which is an enhancement, optimized for handheld terminals, of the DVB-T digital broadcast standard, with which it shares the physical radio environment.
Multimedia System "I"	An end-to-end broadcast system for delivery of any type of digital content and services using IP-based mechanisms, such as those included in the IP Datacast (IPDC) or OMA BCAST specifications. It is based on DVB-SH and provides a way to distribute these contents and services over combined or integrated satellite and terrestrial networks (as described in Appendix 3) to a variety of mobile and fixed terminals having compact antennas and very limited directivity.
Multimedia System "M"	An end-to end system that enables broadcasting of video streams, audio-only streams, digital multimedia files, and data-casting to mobile devices, including handheld receivers. The system is designed to optimize coverage, capacity and power consumption as well as overall user experience for handheld receivers using TIA-1099 air interface standard.

TABLE 2

User requirements of multimedia broadcasting systems for mobile reception by handheld receivers

User requirements	Multimedia System "A"	Multimedia System "B"	Multimedia System "C"	Multimedia System "E"	Multimedia System "F"	Multimedia System "H"	Multimedia System "I"	Multimedia System "M"
<p>High quality multimedia for handheld receivers</p> <p>a) Media type with quality characteristics</p> <ul style="list-style-type: none"> - Resolution - Frame rate - Bit rate 	<p>Video 1:</p> <ul style="list-style-type: none"> - Normally, QVGA, WDF - Up to 30 fps - Various resolutions and frame rates supported <p>Video 2:</p> <ul style="list-style-type: none"> - Normally, VGA - Up to 30 fps - Backward compatibility with Video 1 supported <p>Audio 1:</p> <ul style="list-style-type: none"> - Stereo - Up to 128 kbit/s <p>Audio 2:</p> <ul style="list-style-type: none"> - Surround - Backward compatibility with Audio 1 supported 	<p>"N" Video services:</p> <ul style="list-style-type: none"> - Each normally 416 × 240 - Up to 30P fps - Various frame rates supported <p>Each supplemented by:</p> <ul style="list-style-type: none"> - SVC for higher spatial resolution (to 832 × 480) and/or higher temporal resolution up to 60P fps <p>"N" Audios:</p> <ul style="list-style-type: none"> - Stereo - Up to 288 kbit/s <p>HiQ Audio 2:</p> <ul style="list-style-type: none"> - Surround enabled <p>Bit rate/service:</p> <ul style="list-style-type: none"> - Highly variable up to ~7 Mbit/s total 	<p>Video:</p> <ul style="list-style-type: none"> - Normally, QVGA (320 × 240) or 320 × 180 size - 15~30 fps - Various resolutions and frame rates supported <p>Audio:</p> <ul style="list-style-type: none"> - Stereo 	<p>Video:</p> <ul style="list-style-type: none"> - Normally, QVGA (320 × 240) size - Various resolutions and frame rates supported <p>Audio:</p> <ul style="list-style-type: none"> - Stereo 	<p>Video:</p> <ul style="list-style-type: none"> - Normally QVGA (320 × 240) and 525SD (720 × 480) size - 7.5-30 fps - 64 kbit/s to 10 Mbit/s - Various resolutions and frame rates supported <p>Audio:</p> <ul style="list-style-type: none"> - Stereo and surround 	<p>Video:</p> <ul style="list-style-type: none"> - QVGA, WQVGA - Up to 30 fps - Up to 768 kbit/s⁽¹⁾ per service stream - Various resolutions and frame rates supported <p>Audio:</p> <ul style="list-style-type: none"> - Stereo - From ~20 kbit/s up to 192 kbit/s 	<p>Video:</p> <ul style="list-style-type: none"> - QVGA, WQVGA as well as other display resolutions - Up to 30 fps - Up to 768 kbit/s⁽¹⁾ per service stream - Various resolutions and frame rates supported <p>Audio:</p> <ul style="list-style-type: none"> - Stereo - From ~20 kbit/s up to 192 kbit/s 	<p>Video:</p> <ul style="list-style-type: none"> - QVGA, WQVGA as well as other display resolutions - Up to ~2.25 Mbit/s per stream - Up to 30 fps <p>Audio:</p> <ul style="list-style-type: none"> - Stereo and mono - ~12 kbit/s and higher bit rate can be supported

TABLE 2 (continued)

User requirements	Multimedia System "A"	Multimedia System "B"	Multimedia System "C"	Multimedia System "E"	Multimedia System "F"	Multimedia System "H"	Multimedia System "I"	Multimedia System "M"
a) Media type with quality characteristics (cont.)	Data: <ul style="list-style-type: none"> – Binary data, text, still images – Subtitling (synchronized hypertext with A/V) – Typical combination of AV is QVGA/VGA at 30 fps with stereo/surround audio 	Data: <ul style="list-style-type: none"> – Binary data, text, still images – CEA708 closed captioning – OMA RME interactivity – OMA BCAST SG – Typical AV combination is 416 × 240 × 29.97P with stereo audio 	Others: <ul style="list-style-type: none"> – Still images – Text – Closed caption 	Others: <ul style="list-style-type: none"> – Still images – Text – (Closed caption) 	Others: <ul style="list-style-type: none"> – Binary data, text, still images – Audio/video file distribution 	Data: <ul style="list-style-type: none"> – Binary data, text, still images – Subtitling (synchronized hypertext with A/V) – Typical combination of AV is QVGA at 30 fps with 300 kbit/s, and stereo audio 48 kbit/s 	Data: <ul style="list-style-type: none"> – Binary data, text, still images – Subtitling (synchronized hypertext with A/V) – Typical combination of AV is QVGA at 30 fps with 300 kbit/s, and stereo audio 48 kbit/s 	Data: <ul style="list-style-type: none"> – Binary data – Text, closed captions – Still images – Subtitling – Data, audio/video file distribution – Quality of service per media type – Video and audio data rates range from ~2.25 Mbit/s down to 12 kbit/s
b) Monomedia coding: <ul style="list-style-type: none"> – Video – Audio 	Video: <ul style="list-style-type: none"> – H.264/MPEG-4 AVC – H.264/MPEG-4 SVC Audio: <ul style="list-style-type: none"> – MPEG-4 ER BSAC – MPEG-4 HE-AAC v2 – MPEG Surround – MPEG-1/MPEG-2 Audio Layer II 	Video: <ul style="list-style-type: none"> – H.264/MPEG-4 AVC – H.264/MPEG-4 SVC Audio: <ul style="list-style-type: none"> – MPEG-4 HE-AAC v2 (SBR, PS) 	Video: <ul style="list-style-type: none"> – MPEG-4 AVC/H.264 Audio: <ul style="list-style-type: none"> – AAC (SBR optional) – AIFF-C – Stream and file type playback supported 	Video: <ul style="list-style-type: none"> – MPEG-4 – MPEG-4 AVC/H.264 Audio: <ul style="list-style-type: none"> – AAC (SBR optional) – AIFF-C 	Video: <ul style="list-style-type: none"> – MPEG-4 AVC/H.264 Audio: <ul style="list-style-type: none"> – MPEG-2 AAC – MPEG Surround – MPEG-4 HE-AAC – MPEG-4 HE-AAC v2 – Stream and file type playback supported 	Video: <ul style="list-style-type: none"> – H.264/AVC – VC-1 (optional) Audio: <ul style="list-style-type: none"> – HE AAC v2 – AMR-WB + (Optional for improved low data rate and especially speech service performance) 	Video: <ul style="list-style-type: none"> – H.264/AVC – VC-1 (optional) Audio: <ul style="list-style-type: none"> – HE AAC v2 – AMR-WB + (Optional for improved low data rate and especially speech service performance) 	Video: <ul style="list-style-type: none"> – H.264/AVC Audio: <ul style="list-style-type: none"> – HE AAC-v2

TABLE 2 (continued)

User requirements	Multimedia System "A"	Multimedia System "B"	Multimedia System "C"	Multimedia System "E"	Multimedia System "F"	Multimedia System "H"	Multimedia System "I"	Multimedia System "M"
b) Monomedia coding (cont.): – Other	Data format: – JPEG, PNG, MNG, BMP, etc. – ASCII text, etc.	Data format: – JPEG, PNG. – Optional self-declared MIME formats	Still images: – JPEG – GIF	Still images: – JPEG – PNG – MNG	Data format: – MP4 file – JPEG, PNG, GIF, MNG, BMP, etc.	Data format: – 3GP and MP4 file – JPEG, GIF, PNG – Character encoded (3GPP Timed text) or bitmap based subtitling	Data format: – 3GP and MP4 file – JPEG, GIF, PNG – Character encoded (3GPP Timed text) or bitmap based subtitling	Data format: – MPEG4 files – JPEG – BMP – Timed text subtitles based on 3GPP – Auxiliary data capability providing extensibility to support of additional data types
Flexible configuration of services: – Audio/video – Ancillary and auxiliary data	– Real-time audio and video – Digital radio – Multimedia object file casting via carousel system – Electronic Programme Guide (EPG) – Subtitling (synchronized hypertext with A/V via MPEG-4 BIFS)	– Real-time audio and video – Digital radio – Multimedia object file casting via FLUTE – OMA BCAST SG	– Any combination of real-time audio, video, and data broadcast is available – Electronic Programme Guide – Appropriate service that fits licensed service area can be offered	Two or more CDM channels are combined into one logical channel. This mechanism provides flexible configuration using audio, multimedia and data services	– Any combination of real-time audio, video, and data broadcast is available – Electronic Programme Guide – Appropriate service that fits licensed service area can be offered	– Real-time audio and video – Digital radio. – Scheduled content and file download/ file carousel. – Electronic Service Guide (ESG) – Subtitling (synchronized hypertext with A/V)	– Real-time audio and video – Digital radio. – Scheduled content and file download/ file carousel – Electronic Service Guide (ESG) – Subtitling (synchronized hypertext with A/V)	– Real-time audio and video – Scheduled content and file download based on network load – IP data streams – Electronic programme guide

TABLE 2 (continued)

User requirements	Multimedia System "A"	Multimedia System "B"	Multimedia System "C"	Multimedia System "E"	Multimedia System "F"	Multimedia System "H"	Multimedia System "I"	Multimedia System "M"
Flexible configuration of services: (cont.)	<ul style="list-style-type: none"> – Any combination of the previous contents in the same multiplex and with T-DAB services – T-DMB 5 real-time streaming services (QVGA at 30 fps with 368 kbit/s, and stereo audio 48 kbit/s) per 1.536 MHz spectrum of DMB ensemble – AT-DMB: T-DMB + additional 2~3 video services or T-DMB + 1 VGA real-time video streaming service – National/local broadcast using combination of SFN and MFN 	<ul style="list-style-type: none"> – Any combination of the previous contents in the same multiplex – National/local broadcast using service identification 		Because of the nature of BSS (sound) system, the licensed area is national, however gap fillers can provide local services technically	<ul style="list-style-type: none"> – Subtitling (synchronized hypertext with A/V) – National/local area content with SFN network 	<ul style="list-style-type: none"> – Any mix of the previous contents in the same multiplex and with DVB-T services. – 30 real-time streaming services (QVGA at 30 fps with 300 kbit/s, and stereo audio 48 kbit/s) per ~11 Mbit/s channel (8 MHz spectrum) – National/local area content with SFN network 	<ul style="list-style-type: none"> – 30 real-time streaming services (QVGA at 30 fps with 300 kbit/s, and stereo audio 48 kbit/s) per ~11 Mbit/s channel (8 MHz spectrum) – National/local area content with SFN network 	<ul style="list-style-type: none"> – Support of national and local area coverage within one single or multiple RF carriers – Up to 30 real-time video plus audio streaming services at QVGA, 30 fps, 34 dB minimum PSNR (16-QAM 1/2, C/N = 13.5 dB in typical urban mobile environment)
Conditional access	Supported	Standardized service protection supported over IP via OMA DRM 2.0.	Applicable	Supported	Applicable	Standardized service purchase and protection supported over IP	Standardized service purchase and protection supported over IP	Supported

TABLE 2 (continued)

User requirements	Multimedia System "A"	Multimedia System "B"	Multimedia System "C"	Multimedia System "E"	Multimedia System "F"	Multimedia System "H"	Multimedia System "I"	Multimedia System "M"
Seamless service access	Supported	Supported	Applicable	Applicable	Applicable	Supported; end user moving from one (home) mobile broadcast network to another network is able to access broadcast services provided by the visited network, using the authorization of the original (home) service provider	Supported; end user moving from one (home) mobile broadcast network to another network is able to access broadcast services provided by the visited network, using the authorization of the original (home) service provider	Supported
Fast discovery and selection of content and services	<ul style="list-style-type: none"> - T-DMB Electronic Programme Guide supported: Support for fast discovery and selection of services based on various criteria, acquisition information for services access 	<ul style="list-style-type: none"> - Direct service signalling for sub-second channel acquisition - OMA SG support for fast selection of services based on various criteria, and details about programmes - Content advisories 	Electronic Programme Guide support for discovery and selection of services	Electronic Programme Guide support for discovery and selection of services based on various criteria, acquisition information for services access and content consumption, purchase information	Electronic Programme Guide based on SI/PSI of MPEG-2 systems and metadata with XML schema (ITU-T H.750)	Standardized Electronic Service Guide over IP: Support for fast discovery and selection of services based on various criteria, acquisition information for services access and content consumption, purchase information	Standardized Electronic Service Guide over IP: Support for fast discovery and selection of services based on various criteria, acquisition information for services access and content consumption, purchase information	Network independent service discovery and Electronic Programme Guide supported over broadcast network supported IP data services over broadcast and interactivity channel Support for fast service acquisition, and service switching time, scheduled content delivery

TABLE 2 (continued)

User requirements	Multimedia System "A"	Multimedia System "B"	Multimedia System "C"	Multimedia System "E"	Multimedia System "F"	Multimedia System "H"	Multimedia System "T"	Multimedia System "M"
Low power consumption for handheld receivers	<ul style="list-style-type: none"> – Low power consumption feature of DAB is applied – Optimized narrow bandwidth allows low system clock frequency and simple FFT calculation. Supports sub-channel decoding for selected service 	<ul style="list-style-type: none"> – Low power consumption via time slicing 	Narrow bandwidth enables low system clock frequency	The broadcasting system has a mechanism for using limited number of CDM channels for receiving broadcast services. This allows for lower power consumption of receivers	Narrow bandwidth enables low system clock frequency	<p>Time slicing (~90% power saving compared to continuous reception in the DVB-H receiver part)</p> <p>The viewing time is not limited by the DVB-H receiver but by the video/audio decoders, displays and speakers</p>	<p>Time slicing (~90% power saving compared to continuous reception in the DVB-SH receiver part)</p> <p>The viewing time is not limited by the DVB-SH receiver but by the video/audio decoders, displays and speakers</p>	Supports selective access to desired content (partial signal demodulation) which is achieved in both time and frequency domains Data is transmitted (synchronously) from the transmitter station to the handset every second. Each transmission has therefore 1 second duration and includes the information required by the receiver to demodulate only that portion of the data (service) that the user is interested in

TABLE 2 (continued)

User requirements	Multimedia System "A"	Multimedia System "B"	Multimedia System "C"	Multimedia System "E"	Multimedia System "F"	Multimedia System "H"	Multimedia System "I"	Multimedia System "M"
Provision of interactivity	Supports hypertext linkage using mobile telecommunication network and Internet MPEG-4 BIFS provides frame-synchronized overlay of animated text and graphics objects upon natural scenes	Supports OMA RME for frame-synchronized overlay of animated text and graphics objects	BML supports both local and bidirectional interactivity	BML supports both local and bidirectional interactivity	BML supports both local and bidirectional interactivity	Supports local and remote interactive applications using IMT and/or digital cellular networks or other IP connections Electronic service guide provides the basic access information to enable interactive services	Supports local and remote interactive applications using IMT and/or digital cellular networks or other IP connections Electronic service guide provides the basic access information to enable interactive services	Interactivity content and applications use: – References to interactive services available on the devices or remotely located – Return channel using IMT networks, and/or other IP connections
Interoperability with mobile telecommunication networks	Support for traditional and mobile telecommunication network and Internet, e.g., IMT-2000 networks, IEEE 802.1x, etc.	Support independent of any bearer layer for mobile telecommunication network and Internet for both IPv4 and IPv6.	Delivery networks such as communication or broadcasting network are clearly identified	Delivery networks such as communication or broadcasting network are clearly identified	Delivery networks such as communication or broadcasting network are clearly identified Same IP-based solutions, optimized for handheld device reception, used to enable delivery of services over both broadcast and mobile cellular networks (3GPP)	Same IP-based solutions, optimized for handheld device reception, used to enable delivery of services over both broadcast and mobile cellular networks (3GPP) Maximum harmonization with e.g., A/V codecs, payload formats, content delivery protocols	Same IP-based solutions, optimized for handheld device reception, used to enable delivery of services over both broadcast and mobile cellular networks (3GPP) Maximum harmonization with, e.g., A/V codecs, payload formats, content delivery protocols	Support for traditional voice and data services over mobile telecommunication networks such as IMT-2000 systems Platforms harmonization enabled via IP

TABLE 2 (continued)

User requirements	Multimedia System "A"	Multimedia System "B"	Multimedia System "C"	Multimedia System "E"	Multimedia System "F"	Multimedia System "H"	Multimedia System "I"	Multimedia System "M"
Support for efficient and reliable delivery (transport) mechanisms of services	<p>MPEG-2 TS transport protocol compatible with digital television</p> <ul style="list-style-type: none"> – MPEG-4 SL for adaptation of MPEG-4 – Streaming to MPEG-2 TS – Allows guaranteed RS code in digital broadcasting as FEC code – Any IP based contents can be delivered by IP tunnelling method – Aggregate bit rate for total real time streaming service is 1.152 Mbit/s per 1.536 MHz spectrum of T-DMB ensemble for mobile environment 	<p>IP-based transport protocol</p> <ul style="list-style-type: none"> – Turbo and RS coding options for FEC – RTP/RTCP with transport buffer model for A/V synch – FLUTE for data objects/files 	<p>Transport protocol based on MPEG2-TS</p>	<p>Transport protocol based on MPEG-2 TS</p>	<p>Transport protocol based on MPEG2-TS</p> <p>FLUTE/ALC for file download delivery</p> <p>Optional application layer FEC supported for file delivery</p>	<p>Standard IP-based technologies fully deployed: RTP for streaming, FLUTE/ALC for file download delivery</p> <p>Optional application layer FEC supported for file delivery</p>	<p>Standard IP-based technologies fully deployed: RTP for streaming, FLUTE/ALC for file download delivery</p> <p>Optional application layer FEC supported for file delivery</p>	<p>Transport protocol similar to MPEG2-TS</p> <ul style="list-style-type: none"> – Real-time streaming media is delivered directly to a sync layer – IP is used for delivery of "non real-time" content or data (text and graphics)

TABLE 2 (end)

User requirements	Multimedia System "A"	Multimedia System "B"	Multimedia System "C"	Multimedia System "E"	Multimedia System "F"	Multimedia System "H"	Multimedia System "I"	Multimedia System "M"
Support for efficient and reliable delivery (transport) mechanisms of services (cont.)	<ul style="list-style-type: none"> - Aggregate bit rate for total real time streaming service is 1.728 Mbit/s per 1.536 MHz spectrum of AT-DMB ensemble for mobile environment - Small overhead for data delivery (MPEG-2 TS and MPEG-4 SL) 							

(1) Maximum bit rates limited for handheld receivers through profiling the general specifications for cost-efficient device implementation.

TABLE 3

Normative references for multimedia broadcasting systems for mobile reception by handheld receivers

	Multimedia System "A"	Multimedia System "B"	Multimedia System "C"	Multimedia System "E"	Multimedia System "F"	Multimedia System "H"	Multimedia System "I"	Multimedia System "M"	
Encapsulation and protocols for transmission of content	ETSI EN 300 401 ETSI TS 102 427 ISO/IEC 13818-1 ISO/IEC 14496-1 ISO/IEC 14496-11 ETSI TR 101 497 ETSI TS 101 759 ETSI ES 201 735 ETSI TS 101 499 ETSI TS 101 498-1 ETSI TS 101 498-2	ATSC A/153 Part 2 ATSC A/153 Part 3 IETF: STD05 IETF: STD06 IETF: RFC 3550 IETF: draft-ietf-avt-rtp-rfc3984bis-06 IETF: draft-ietf-avt-rtp-svc-18 IETF: RFC 3640 IETF: RFC 3926 OMA: OMA-TS-BCAST_Distribution-V1_0 IETF: draft-ietf-ntp-ntpv4-proto-11 ATSC A/153 Part 4 OMA-TS-BCAST_Service_Buide-V1_0		Recs ITU-R BT.1207, ITU-R 1209 and ITU-R BT.1300 ISO/IEC 13818-1 MPEG-2 Systems ISO/IEC 13818-6 IETF RFC 4326 IETF RFC 3095 Rec. ITU-R BT.1869 IETF RFC 3926 ARIB STD-B24 Volume 3 Data Carousel			ETSI EN 302 304 ETSI TS 102 470 ETSI TS 102 472		TIA-1099
Multimedia Content Format	ETSI EN 301 234 TTAK.KO-07.0071	ATSC A/153 Part 5 OMA-TS-RME-V1_0-20081014-C		Recs ITU-R BT.1699 and ITU-T J.201 ARIB STD-B24 Volume 2 BML		ETSI TS 102 005		ISO/IEC 14496-14	

TABLE 3 (end)

		Multimedia System “A”	Multimedia System “B”	Multimedia System “C”	Multimedia System “E”	Multimedia System “F”	Multimedia System “H”	Multimedia System “T”	Multimedia System “M”
Mono-media coding	Audio coding	ISO/IEC 11172-3 and 13818-3 ISO/IEC 14496-3 for MPEG-4 ER BSAC/MPEG-4 HE-AAC V2 + MPEG Surround ISO/IEC 23003-1 ETSI TS 102 428 TTAK.KO-07.0071	ISO/IEC 14496-3:2005 for MPEG-4 (HE-AAC V2) ATSC A/153 Part 8	ISO/IEC 13818-7 MPEG-2 AAC ISO/IEC 14496-3 MPEG-4 HE-AAC, HE-AACv2 ISO/IEC 23003-1			ETSI TS 102 005		IEO/IEC 14496-3/2001: Amd. 4
	Video coding	ITU-T Rec. H.264 and ISO/IEC 14496-10 MPEG-4 AVC ITU-T Rec. H.264 and ISO/IEC 14496-10 MPEG-4 SVC ETSI TS 102 428 TTAK.KO-07.0071	Rec. ITU-T H.264 and ISO/IEC 14496-10 MPEG-4 AVC Rec. ITU-T H.264 and ISO/IEC 14496-10 MPEG-4 SVC ATSC A/153 Part 7	ITU-T Rec. H.264 and ISO/IEC 14496-10 MPEG-4 AVC			ETSI TS 102 005		ISO/IEC 14496-2 /10 MPEG-4 AVC
	Others, e.g., binary data/text, still picture, etc.	ETSI EN 301 234 (Note 2)		ARIB STD-B24 Volume 1 Part 2 (see Note 1)			ETSI TS 102 005 ETSI TS 102 471 ISO/IEC 10918 (JPEG)		ISO/IEC 10918 (JPEG)

NOTE 1 – ARIB STD-B24 Volume 1 Part 2 defines available encoding schemes and encoding parameters for still pictures, animation and characters in addition to audio and video. It covers JPEG, PNG, MNG, MPEG-2-I, MPEG-1 video, PCM sound, JIS 8-bit characters and UCS.

NOTE 2 – ETSI EN 301 234 defines the multimedia object transfer protocol that delivers MP4 files (ISO/IEC 14496-14) in addition to multimedia files such as JPEG, PNG, MNG, and BMP.

NOTE 1 – The Standards and Recommendations that are normatively or informatively referenced in Table 3 are available at the websites of the respective Standards Development Organizations:

- www.iso.org
- www.etsi.org
- www.tiaonline.org
- www.arib.or.jp
- www.ietf.org
- www.tta.or.kr
- www.atsc.org
- openmobilealliance.org

4 Summaries of multimedia systems

4.1 Multimedia System “C” (ISDB-T), and Multimedia System “F” (ISDB-T multimedia broadcasting for mobile reception)

System C of Recommendation ITU-R BT.1306, also known as ISDB-T, provides hierarchical transmission features. This enables allocation of signals for mobile reception that requires greater robustness in the same channel as that for stationary reception. Use of “OFDM segments”, units of OFDM carriers corresponding to 1/13 of a channel, is a key technique for this.

In ISDB-T, the transmission parameters of the modulation scheme of OFDM carriers, the coding rates of inner error correcting code, and the length of the time interleaving can be independently specified for each segment. One or more segments form a segment group of up to three per channel. A segment group is the basic unit for delivering broadcast services, hence transmission parameters of the segments are common within the group.

The centre segment is a special segment that is suitable for establishing a segment group having only one segment. When only the centre segment forms a segment group, the segment can be received independently. This is called partial reception.

The digital System F of Recommendation ITU-R BS.1114, also known as ISDB-T_{SB}, is designed for sound, multimedia, and data broadcasting using the concept of a narrow-band variation of ISDB-T. There are either one or three segments for ISDB-T_{SB}. When there is one segment, a receiver for this is compatible with partial reception of ISDB-T.

Multimedia System F is designed for real-time and non-real-time broadcasting of video, sound, and multimedia content for mobile and handheld receivers with the common technology of the ISDB-T and ISDB-T_{SB} systems. The number of segments for this system can be chosen in accordance with the application and available bandwidth. The spectrum is formed by combining 1-segment, 3-segment, and/or 13-segment blocks without a guard band. Figure 1-1 shows the three basic compositions of transmission signals, and Fig. 1-2 shows example combinations of the segment blocks. A receiver can partially demodulate a 1-, 3- or 13-segment part so that the hardware and software resources for ISDB-T or ISDB-T_{SB} receivers can be used to make receivers for the ISDB-T multimedia broadcasting for mobile reception.

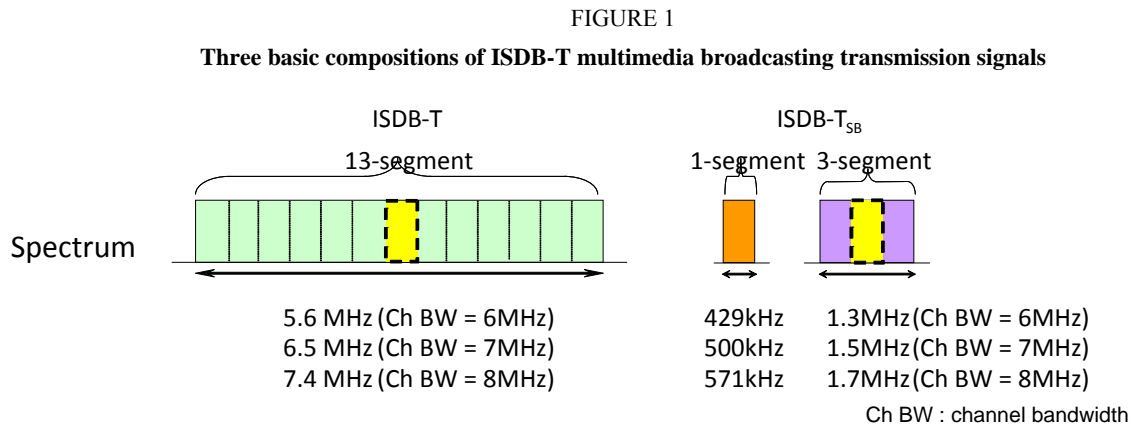

1833-01

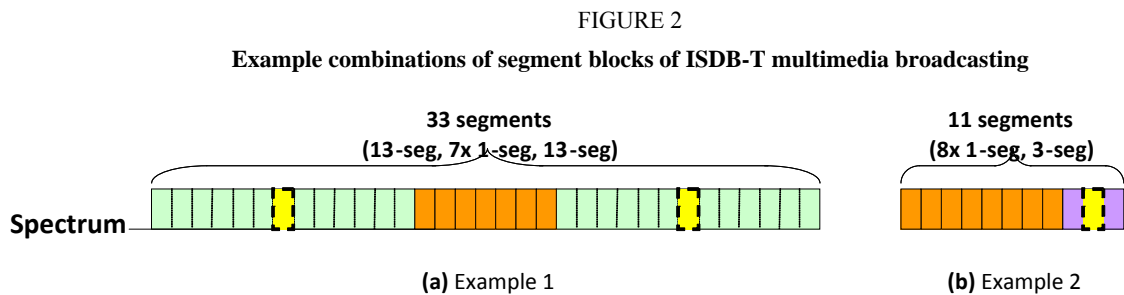

1833-02

4.2 Multimedia System “E”

The system is designed to provide satellite and complementary terrestrial on-channel repeater services providing high-quality digital audio, medium quality video, multimedia and data services for portable, vehicular and fixed reception. It has been designed to optimize the performance of satellite and terrestrial on-channel repeater services. This is achieved through the use of CDM (code-division multiplex) based on QPSK modulation with concatenated code using Reed-Solomon code and convolutional error correcting code. The Digital System E receiver uses state-of-the-art microwave and digital large-scale integrated circuit technology with the primary objective of achieving low-cost production and high-quality performance.

The main features of this system are as follows:

1. MPEG-2 Systems architecture facilitates multiplexing of many broadcasting services and interoperability with other digital broadcasting services. This is the first BSS (sound) system to adopt MPEG-2 Systems.
2. MPEG-2 AAC, optionally plus SBR (spectral band replication), is adopted for audio source coding. It gives the most efficient audio compression performance for high quality digital audio broadcasting services at targeted transmission speeds of this system.
3. Portable reception is one of the major targets of this system. Handheld receivers have been developed with 3.5 inch wide LCD display.
4. Vehicular reception is another of the major targets of this system. Listeners/viewers can enjoy stable reception in high-speed vehicles in a broadcasting environment.
5. Satellite signals can be received by mobile receivers using an omnidirectional single-element antenna in the horizontal plane and a two-antenna diversity reception scheme.

4.3 Multimedia System “A” (T-DMB and Advanced T-DMB)

Multimedia System ”A”, also known as Terrestrial digital multimedia broadcasting (T-DMB) system, is the extended system compatible with digital sound broadcasting system A, which enables video services using T-DAB networks for handheld receivers in a mobile environment.

T-DMB provides multimedia services including video, audio, and interactive data. For audio services it uses ISO/IEC 11172-3, 13818-3 and 23003-1 for MPEG-1/MPEG-2 Audio Layer II as specified in DSB System A, MPEG-4 ER-BSAC or MPEG-4 HE AAC v2 + MPEG Surround. For video services ITU-T H.264 | MPEG-4 AVC standard is used for video, MPEG-4 ER-BSAC or MPEG-4 HE AAC v2 + MPEG Surround for the associated audio, and MPEG-4 BIFS and MPEG-4 SL for interactive data. Outer channel coding of Reed-Solomon code is applied to provide stable performance of video reception.

AT-DMB is the extended system of guaranteeing backward compatibility with T-DMB, which increases channel capacity of T-DMB by applying hierarchical modulation mechanism. Therefore, basic parameters of AT-DMB such as channel bandwidth, number of carriers, symbol duration, guard interval duration, etc., are the same as those of T-DMB.

AT-DMB provides a scalable video service as well as all kinds of T-DMB services. The scalable video service fully guarantees backward compatibility with the video service of T-DMB. It can serve VGA quality video service to AT-DMB receivers, QVGA quality video service to T-DMB receivers. For audio of the scalable video service, it uses ISO/IEC 23003-1 for MPEG-4 ER-BSAC or MPEG-4 HE AAC v2 + MPEG Surround. For video of the scalable video service, it uses base line profile of ITU-T Recommendation H.264 | ISO/IEC 14496-10 amendment 3 for MPEG-4 SVC.

Current Status of T-DMB Services and Advanced T-DMB are included in the Report ITU-R BT.2049. The specification of T-DMB was standardized by ETSI in 2005. ETSI TS 102 427 and ETSI TS 102 428 describe the error protection mechanism and the A/V codec of the T-DMB system, respectively. A variety of receivers are on the market: PC (laptop) type, vehicular type, and PDA type, as well as mobile phones. The specification of AT-DMB was standardized by TTA in 2009. TTAK.KO-07.0070/R1 describes hierarchical modulation scheme, error correction code, etc. TTAK.KO-07.0071 describes transmission mechanism for scalable video service.

4.4 Multimedia System “H” (DVB-H) and Multimedia System “I” (DVB-SH)

Multimedia System “H” and Multimedia System “I” are end-to-end broadcast systems for delivery of any types of digital content and services using IP-based mechanisms optimized for devices with limitations on computational resources and battery. They consist of a unidirectional broadcast path that may be combined with a bidirectional mobile cellular (2G/3G) interactivity path. The broadcast path of Multimedia System “I” uses combined or integrated satellite and terrestrial networks. Both Multimedia Systems “H” and “I” are platforms that can be used for enabling the convergence of services from broadcast/media and telecommunications domains (e.g., mobile/cellular).

The system specifications can be divided into the following categories:

- General end-to-end system descriptions.
- DVB-H and DVB-SH radio interfaces.
- IP-based services delivery over DVB-H and DVB-SH service layer.
- IP-based services delivery codecs and content formats.

DVB-H is an enhancement of the widely accepted DVB-T digital broadcast standard for mobile broadcast reception. DVB-H is RF-compatible with DVB-T and can share the same radio environment. The DVB-H radio interface specification is ETSI EN 302 304. The DVB-SH radio interface specification is ETSI EN 302 583.

DVB-H and DVB-SH system signalling specifications define the exact use of PSI/SI information in case of an IP-based services delivery.

For video services H.264/AVC and for audio HE AAC v2 codecs and respective RTP payload formats are used. Several types of data are supported including, e.g., binary data, text and still images.

RTP is the IETF protocol used for streaming services. Delivery of any kind of files in an IP-based services delivery system is supported by the IETF FLUTE protocol.

Electronic Service Guide has been specified to allow fast discovery and selection of services for the end user.

Versatile Service Purchase and Protection mechanisms have been defined for broadcast-only and interaction capable handheld receivers.

Examples of commercial deployments are included, e.g., in the Report ITU-R BT.2049.

4.5 Multimedia System “M”

Multimedia System “M”, also known as Forward Link Only (FLO), is designed specifically for mobile applications and for wireless multimedia services. It was designed for the efficient distribution of multimedia content to multiple users.

The technical characteristics of the FLO physical layer are described in the context of the identified requirements. The result is a new mobile broadcast technology, known as FLO technology.

Standardizing of the FLO technology has been achieved by the Telecommunications Industry Association (TIA) as Standard TIA-1099 and is further coordinated through the FLO Forum, www.floforum.org.

4.6 Multimedia System “B” (ATSC Mobile DTV)

Multimedia System “B”, also known as ATSC Mobile DTV, is designed to allow terrestrial broadcasters using the ATSC digital TV standard to devote a portion of their emission to Mobile and Handheld (M/H) service. System B is designed to provide the characteristics needed for M/H service in a portion of the emission, while not affecting the provision of fixed digital ATSC service using the remaining portion of the emission.

For the M/H service, System B provides additional forward error correction and added training signals. These features provide for reception at lower signal to noise ratios and with much higher rates of Doppler distortion than is possible with the fixed service.

The inclusion of ATSC Mobile DTV in the emission does not affect the characteristics of the ATSC fixed service in either coverage or interference, and thus may be instituted at the individual broadcaster’s discretion without any change in station allocations or transmitter power.

System B uses Internet Protocol for transport and related protocols in the upper layers, providing ready interoperability with other multimedia systems.

System B standards have been published as ATSC Standard Document A/153, Parts 1 to 8.

Annex 2

Multimedia System “C” (ISDB-T one segment), Multimedia System “F” (ISDB-T multimedia broadcasting for mobile reception) and Multimedia System “E”

System specifications for Multimedia System “C” (ISDB-T one segment), Multimedia System “F” (ISDB-T multimedia broadcasting for mobile reception), and Multimedia System “E” are defined in the normative references listed in Table 3.

Additional information for these systems is provided here.

The physical layer specifications of these systems are described in Recommendations ITU-R BT.1306, ITU-R BS.1114 and ITU-R BO.1130 as well as ITU-R BS.1547. Multimedia System C (ISDB-T one segment) and Multimedia System F (ISDB-T multimedia broadcasting for mobile reception) are designed for terrestrial transmission, and Multimedia System E is designed mainly for mobile reception directly from the broadcasting satellite augmented by terrestrial gap fillers.

The protocol stack on the physical layer and above is common among all the ISDB family systems, as shown in Fig. 2.

Multimedia System F has a transport mechanism for Internet protocol (IP) packets to deliver filecast content. While real-time broadcast content is delivered by the same protocol of the existing ISDB-T family, filecast content is transported by either the IP packets encapsulated in MPEG-2 TS or the DSM-CC section of the MPEG-2 TS.

When filecast content is transported by IP packets, that content is divided into fixed-length packets by the file delivery over unidirectional transport (FLUTE) protocol specified in IETF RFC 3926. Some additional forward error correction (FEC) packets are also constructed. After constructing the IP packets, redundancy in their headers is removed by header compression techniques. Either the robust header compression (ROHC) unidirectional mode specified in RFC 3095 or the header compression scheme specified in Recommendation ITU-R BT.1869 can be used. Those header compressed IP packets are encapsulated into MPEG-2 TS packets by the unidirectional lightweight encapsulation (ULE) as specified in IETF RFC 4326.

When filecast content is transported by the DSM-CC section of MPEG-2 TS, download data block (DDB) messages are constructed from the content. The constructed DDB messages are transported in MPEG-2 TS packets with download info indication (DII) messages.

FIGURE 3

Protocol stack of ISDB-T family

IP-based application	Filecasting ⁽¹⁾		Real-time broadcasting
	FLUTE/AL-FEC	Section (including DSM-CC)	PES
UDP/IP			
ROHC or Recommendation ITU-R BT.1869			
ULE			
MPEG-2 TS			
Physical layer			

⁽¹⁾ Filecasting is supported by Multimedia System F. (See Recommendation ITU-R BT.1833)

ARIB STD-B24 covers all types of receivers. Its appendices give the profiles for all types of receivers, from fixed HDTV to basic handheld receivers. Appendix 4 gives a profile for basic handheld receivers that ISDB-T one segment and ISDB-T multimedia broadcasting for mobile reception use. Appendix 5 describes a profile for enhanced handheld and vehicular receivers.

The profile for the basic handheld receiver supports a 240×480 logical screen. Resolution of video is 320×180 (16:9 aspect ratio), 320×240 , or 160×120 (4:3 aspect ratio). In addition to this video resolution, ISDB-T for multimedia broadcasting supports 160×90 , 176×120 , 352×240 , 352×480 , and 720×480 (16:9 aspect ratio), and 176×120 , 176×144 , 352×240 , 352×288 , 352×480 , 640×480 , and 720×480 (4:3 aspect ratio). Actual presentation depends on receiver implementation. For example, screen rotation can give a larger display area that can display video without scaling. When displaying multimedia content, a receiver for this profile is mandated to support such logical screen size by any technical measures where scrolling is a major tool.

For multimedia broadcasting, this profile supports a wide variety of media types. H.264/AVC for video, MPEG2-AAC LC for audio, JPEG, PNG, and GIF for still images, GIF and MNG for animation, and text by Shift-JIS characters are the supported media. Those media are placed on logical screens instructed by tags and stylesheet attributes in BML document(s), while interactivity is controlled by ECMAScript and anchor tags in BML document(s).

File transmission protocol to deliver BML document(s) and other files, such as still images, is achieved by data carousel as shown in Fig. 3. This protocol is also defined in ARIB STD-B24.

The profile for enhanced handheld and vehicular receivers is used by digital System E; video and audio stream data are transmitted using PES over MPEG-2 Transport Stream encapsulation as described in Fig. 3. Encoding methods are MPEG-4 Video including AVC and HE AAC, respectively, as described in Table 3. The display size of target receivers is 320×240 (QVGA) for handheld receivers, which is defined in Appendix 5 to Volume 2 of ARIB STD-B24. A common basic multimedia content structure and delivery mechanism for ISDB family systems, described in ISDB-T one segment and ISDB-T_{SB} systems, is also used for digital System E.

Figure 4 shows display patterns for receivers of digital System E. This type of receiver has a layout that is similar to a fixed receiver, although it is likely to have a different display resolution as illustrated in Fig. 4. A typical receiver has a display of 320×240 resolution, as defined in Appendix 5 to Volume 2 of ARIB STD-B24, while a fixed receiver can have an HDTV display, i.e., $1\,920 \times 1\,080$ resolution.

The text of ARIB STD-B24 is available at: http://www.arib.or.jp/english/html/overview/sb_ej.html.

FIGURE 4

Layout patterns of image and data on enhanced handheld and vehicular receivers

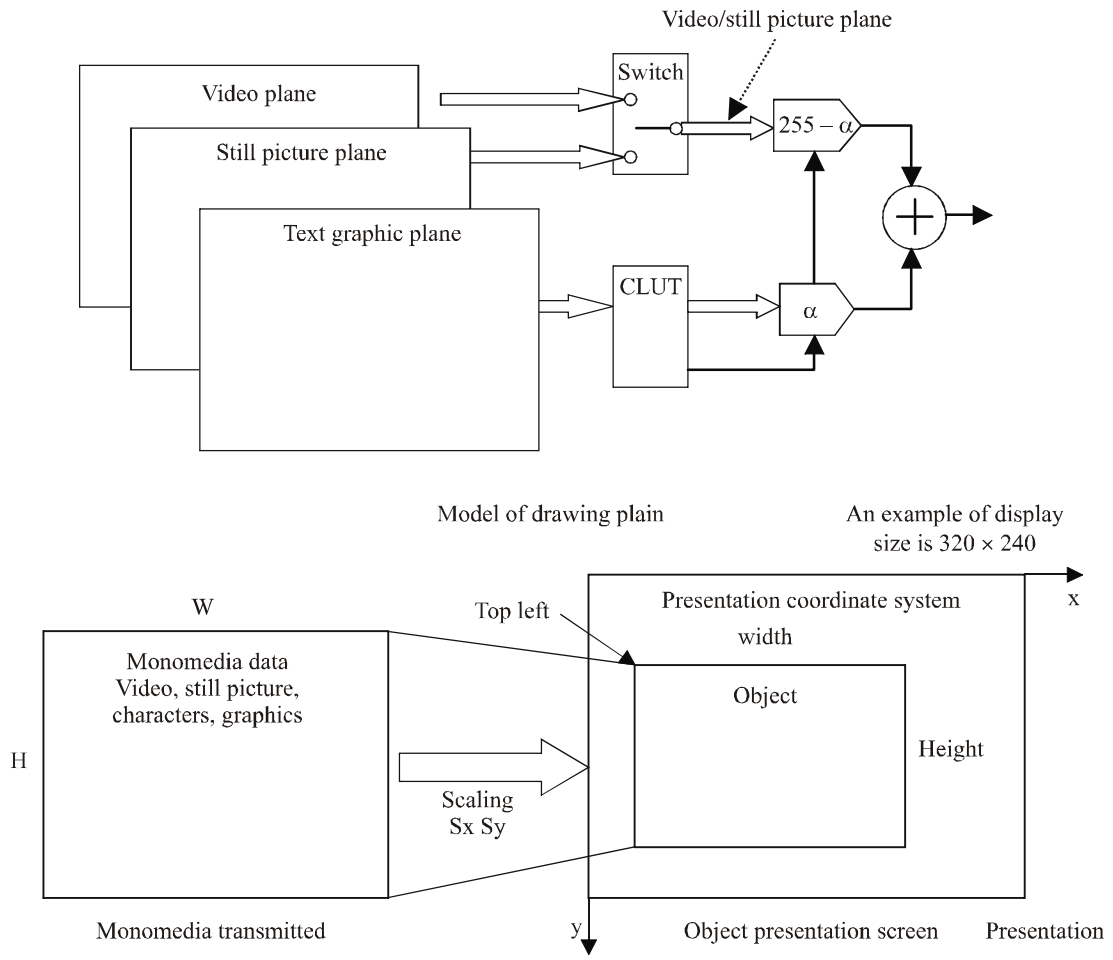

Model of drawing plain

An example of display size is 320×240

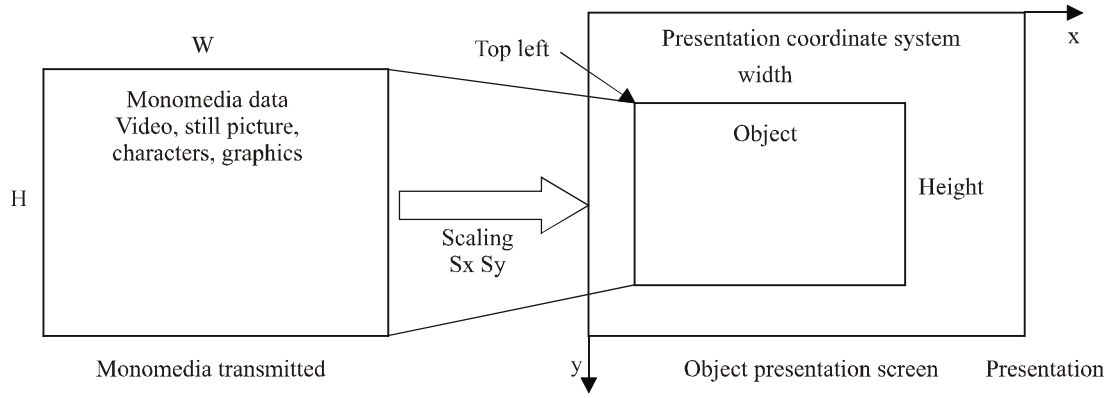

Relation between presentation coordinates and images

Annex 3

Multimedia System “A” (T-DMB and advanced T-DMB)

1 System architecture

The system for video service and scalable video service has an architecture that transmits MPEG-4 content encapsulated using “MPEG-4 over MPEG-2 TS” specification, as illustrated in Fig. 5.

FIGURE 5
Conceptual architecture for video service and scalable video service

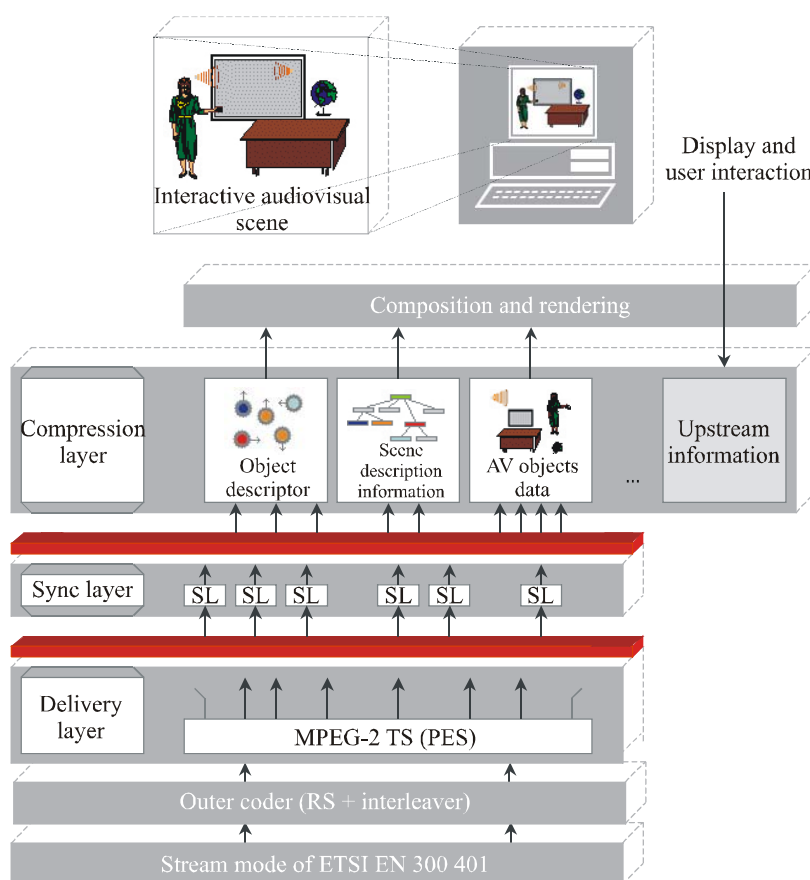

1833-05

Video service and scalable video service are delivered through the stream mode of the DSB System A transmission mechanism. In order to maintain extremely low bit error rates, these services use the error protection mechanism described in ETSI TS 102 427. These video services are composed of three layers: content compression layer, synchronization layer and transport layer. In the content compression layer, Recommendation ITU-T H.264 | ISO/IEC 14496-10 AVC for video service and ITU-T Recommendation H.264 | ISO/IEC 14496-10 amendment 3 SVC for scalable video service are employed for video compression, ISO/IEC 14496-3 ER-BSAC/HE-AAC v2 MPEG Surround for audio compression, and ISO/IEC 14496-11 BIFS for auxiliary interactive data services. For system specifications, see Table 3.

To synchronize audio-visual content, both temporally and spatially, ISO/IEC 14496-1 SL is employed in the synchronization layer. In the transport layer specified in ETSI TS 102 428, some appropriate restrictions are employed for the multiplexing of compressed audiovisual data.

2 Video service transmission architecture

The conceptual transmission architecture for video services is shown in Fig. 6. The video, audio, and auxiliary data information for a video service are multiplexed into an MPEG-2 TS and further outer-coded by the video multiplexer. It is transmitted using the stream mode specified in DSB System A.

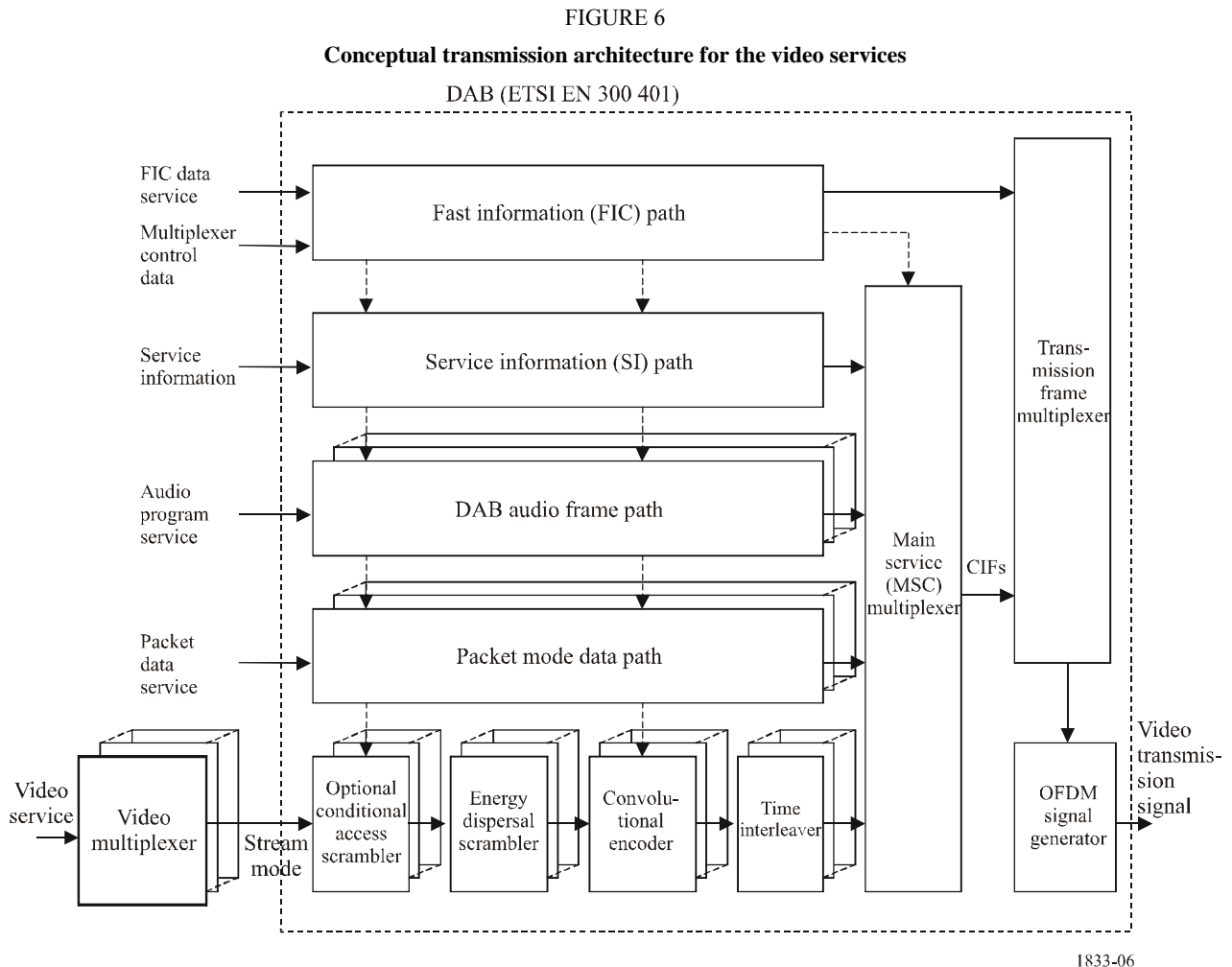

3 Video multiplexer architecture

The conceptual architecture of the video multiplexer for a video service is shown in Fig. 7.

The following are the detailed descriptions:

- The IOD generator creates IODs that comply with the ISO/IEC 14496-1 standard.
- The OD/BIFS generator creates OD/BIFS streams that comply with the ISO/IEC 14496-1 standard.
- The video encoder generates an encoded bit stream compliant with the ITU-T Recommendation H.264/AVC standard by performing data compression processing of the input video signal.
- The audio encoder generates an encoded bit stream compliant with the ISO/IEC 14496-3 ER-BSAC standard by performing data compression processing of the input audio signal.
- Each SL packetizer generates an SL packetized stream compliant with the ISO/IEC 14496-1 System standard for each input media stream.

- The section generator (PSI generator) creates sections compliant with the ISO/IEC 13818-1 standard for the input IOD/OD/BIFS.
- Each PES packetizer generates a PES packet stream compliant with the ISO/IEC 13818-1 standard for each SL packet stream.
- The TS multiplexer combines the input sections and PES packet streams into a single MPEG-2 TS compliant with the ISO/IEC 13818-1 standard.
- The outer encoder attaches additional data, generated by using the RS code for error correction, to each packet in the MPEG-2 TS multiplexed data stream.
- The outer-coded data stream is interleaved by the outer interleaver, which is a convolutional interleaver, and is output as a video service stream.

FIGURE 7

Architecture of the video multiplexer

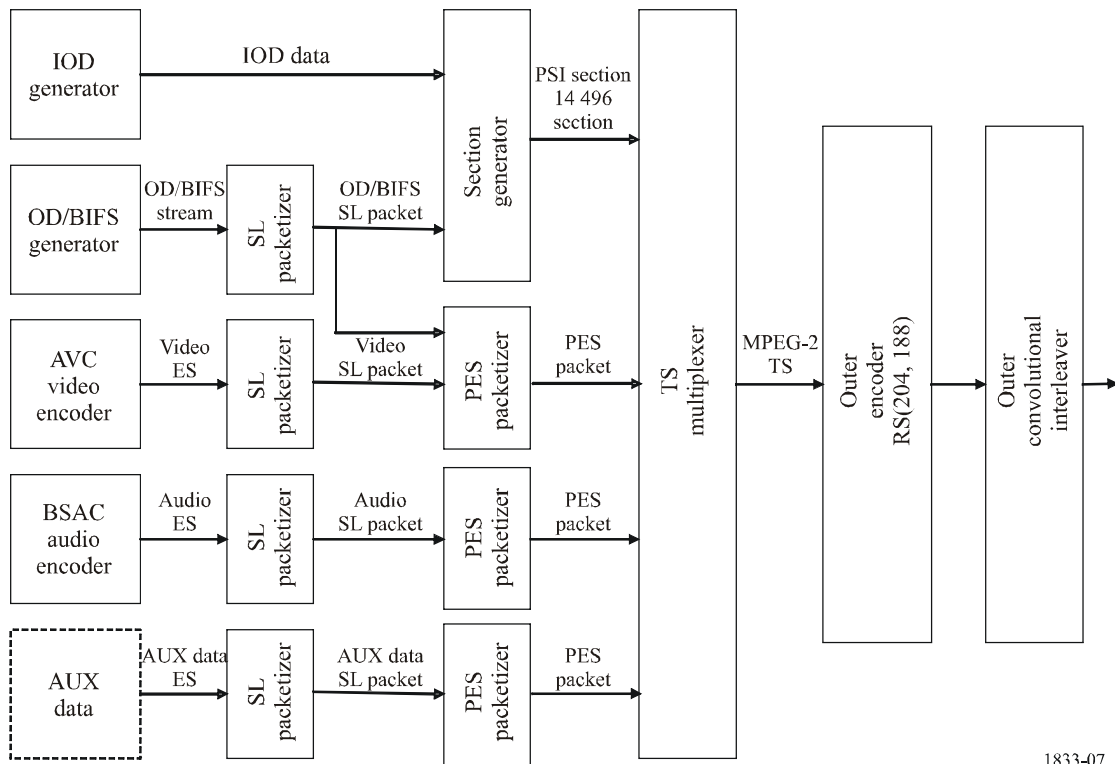

4 Scalable video service transmission architecture

The conceptual transmission architecture for scalable video services is shown in Fig. 8. The video, audio, and auxiliary data information for a scalable video service are multiplexed into an MPEG-2 TS and further outer-coded by the MPEG-4 SVC video multiplexer. It is transmitted using the stream mode specified in AT-DMB.

FIGURE 8

Conceptual transmission architecture for the scalable video service

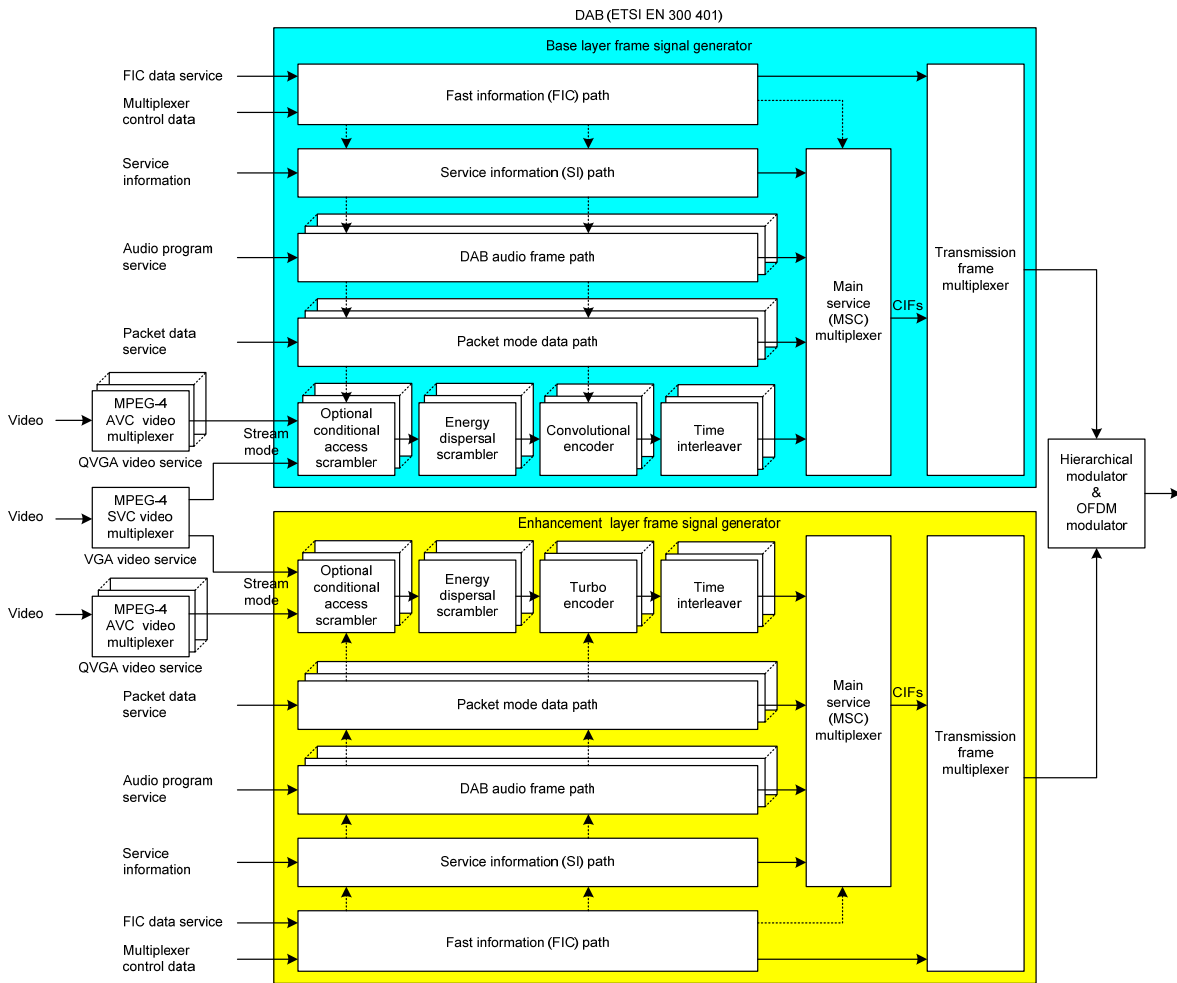

5 SVC video multiplexer architecture

The conceptual architecture of the video multiplexer for a scalable video service is shown in Fig. 9.

The following are the detailed descriptions:

- The video encoder generates an encoded bit stream compliant with the standard “ITU-T Recommendation H.264 | ISO/IEC 14496-10 Amendment 3”.
- The audio encoder generates an encoded bit stream compliant with the standard “ISO/IEC 23003-1 MPEG Audio Technologies – Part 1: MPEG Surround”.
- Base layer video multiplexer applies the procedure of the T-DMB video multiplexer for backward compatibility with the existing T-DMB video services.

- Base layer video multiplexer multiplexes media streams of the base layer and enhancement layer video multiplexer multiplexes media streams of the enhancement layer. The structures of both video multiplexers are basically the same. But the video multiplexer of each layer does both media and stream synchronization.
- ES information is added for media synchronization and TS information is added for stream synchronization.

FIGURE 9

Conceptual architecture of the SVC video multiplexer

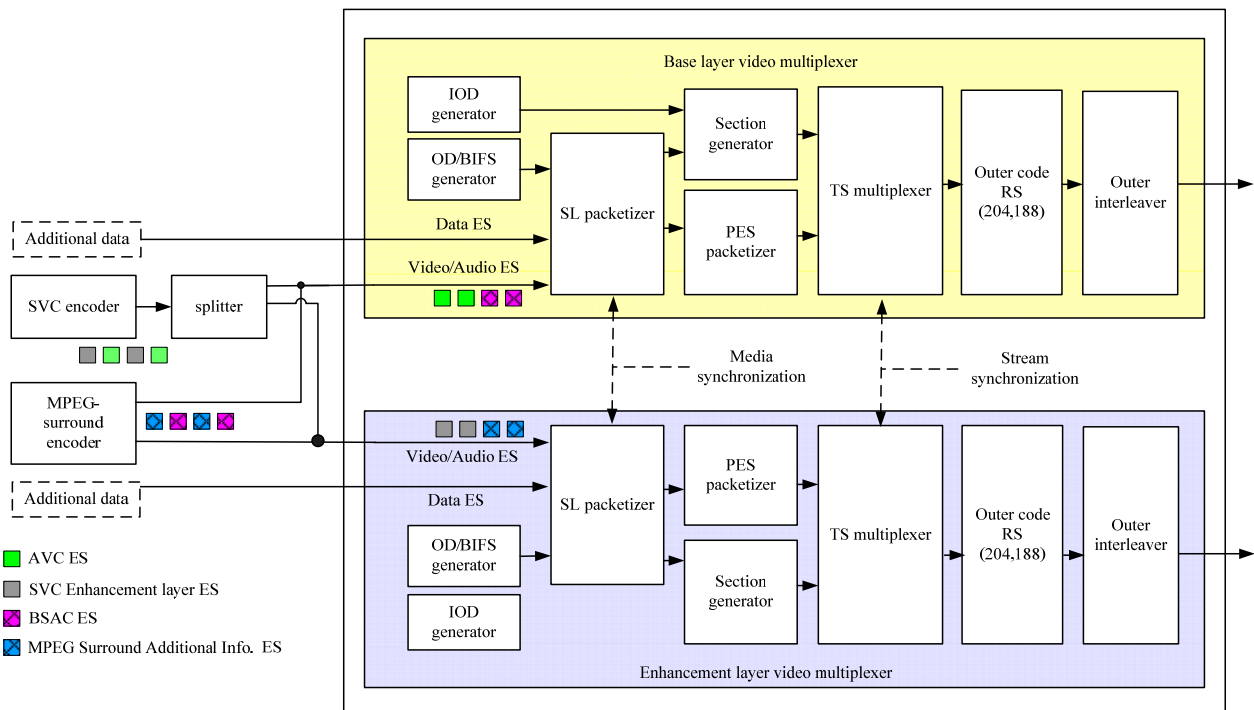

1833-09

Normative references

- [1] Recommendation ITU-R BS.1114 *System A – System for terrestrial digital sound broadcasting to vehicular, portable and fixed receivers in the frequency range 30-3 000 MHz.*
- [2] ETSI EN 300 401: *Radio Broadcasting Systems; Digital Audio Broadcasting (DAB) to mobile, portable and fixed receivers.*
- [3] ISO/IEC 13818-1: *Information Technology – Generic Coding of Moving Pictures and Associated Audio Information: Systems.*
- [4] ISO/IEC 14496-1: *Information technology Coding of audio-visual objects Part 1: Systems.*
- [5] ETSI TS 102 427: *Digital Audio Broadcasting (DAB); Data Broadcasting – MPEG-2 TS Streaming.*
- [6] ETSI TS 102 428: *Digital Audio Broadcasting (DAB); DMB video service; User Application Specification.*
- [7] ISO/IEC 14496-3: *Information Technology – Coding of audio-visual objects: Part 3: Audio.*
- [8] ITU-T Recommendation H.264 | ISO/IEC 14496-10: *Information Technology – Coding of audio-visual objects: Part 10: Advanced Audio Coding.*
- [9] ISO/IEC 14496-11: *Information technology – Coding of audio-visual objects – Part 11: Scene description and application engine.*

- [10] TTAK.KO-07.0070/R1: *Specification of the Advanced Terrestrial Digital Multimedia Broadcasting (AT-DMB) to mobile, portable, and fixed receivers.*
- [11] TTAK.KO-07.0071: *Advanced Terrestrial Digital Multimedia Broadcasting (AT-DMB) Scalable Video Service.*

Informative references

- [12] ETSI TR 101 497: *Digital Audio Broadcasting (DAB); Rules of Operation for the Multimedia Object Transfer Protocol.*
- [13] ETSI TS 101 759: *Digital Audio Broadcasting (DAB); Data Broadcasting – Transparent Data Channel (TDC).*
- [14] ETSI ES 201 735: *Digital Audio Broadcasting (DAB); Internet Protocol (IP) Datagram Tunnelling.*
- [15] ETSI TS 101 499: *Digital Audio Broadcasting (DAB); MOT Slide Show; User Application Specification.*
- [16] ETSI TS 101 498-1: *Digital Audio Broadcasting (DAB); Broadcast Website; Part 1: User Application Specification.*
- [17] ETSI TS 101 498-2: *Digital Audio Broadcasting (DAB); Broadcast Website; Part 2: Basic Profile Specification.*
- [18] ETSI EN 301 234: *Digital Audio Broadcasting (DAB); Multimedia Object Transfer (MOT) Protocol.*
- [19] ETSI TS 102 371: *Digital Audio Broadcasting (DAB); Transportation and Binary Encoding Specification for DAB Electronic Programme Guide (EPG).*
- [20] ETSI TS 102 818: *Digital Audio Broadcasting (DAB); XML Specification for DAB Electronic Programme Guide (EPG).*

Annex 4

Multimedia System “H” (DVB-H) and Multimedia System “I” (DVB-SH)

The standardized “IPDC over DVB-H” and “IPDC over DVB-SH” end-to-end systems are based on the following set of specifications (see also Table 3).

General end-to-end system description

The umbrella specification for all DVB-SH specifications is:

- ETSI TS 102 585: *Digital Video broadcasting (DVB); System Specifications for Satellite services to Handheld devices (SH) below 3 GHz.*

The umbrella specification for all the “IP Datacast over DVB-H” specifications is:

- ETSI TS 102 468: *Digital Video Broadcasting (DVB); IP Datacast over DVB-H: Set of Specifications for Phase 1.*

The use cases applicable to IPDC system are described in:

- ETSI TR 102 473: *Digital Video Broadcasting (DVB); IP Datacast over DVB-H: Use Cases and Services.*

The end-to-end IPDC system architecture is described in:

- ETSI TR 102 469: Digital Video Broadcasting (DVB); IP Datacast over DVB-H: Architecture.

DVB-H and DVB-SH radio interface

The following documents define the DVB-H radio interface.

The DVB-H radio transmission is specified in:

- ETSI EN 302 304: Digital Video Broadcasting (DVB); Transmission System for Handheld Terminals (DVB-H).

The DVB-SH radio transmission is specified in:

- ETSI EN 302 583: Digital Video Broadcasting (DVB); Framing Structure, channel coding and modulation for Satellite Services to handheld devices (SH) below 3 GHz.

The DVB-H and DVB-SH-related system level signalling, applicable both to transmitters and to receivers are specified in:

- ETSI TS 102 470-1: Digital Video Broadcasting (DVB); IP Datacast over DVB-H: Programme Specific Information (PSI)/(Service Information (SI); and ETSI TS 102 470-2: Digital Video Broadcasting (DVB); IP Datacast over DVB-SH: Programme Specific Information (PSI)/(Service Information (SI).

IP Datacast service layer

The following documents define the IP Datacast service layer over DVB-H and DVB-SH.

The Electronic Service Guide is specified in:

- ETSI TS 102 471-1: Digital Video Broadcasting (DVB); IP Datacast over DVB-H: Electronic Service Guide (ESG).

The Content Delivery Protocols are specified in:

- ETSI TS 102 472: Digital Video Broadcasting (DVB); IP Datacast over DVB-H: Content Delivery Protocols.

Service Purchase and Protection mechanisms are specified in:

- ETSI TS 102 474: Digital Video Broadcasting (DVB); IP Datacast over DVB-H: Service Purchase and Protection.

IP Datacast codecs and formats

Audio and video codecs and formats supported are specified in:

- ETSI TS 102 005: Digital Video Broadcasting (DVB); Specification for the use of video and audio coding in DVB services delivered directly over IP.

For further information on the guidelines for deployment of DVB-H and DVB-SH standard please refer to:

- ETSI TR 102 377: “Digital Video Broadcasting (DVB); DVB-H Implementation guidelines”.
- ETSI TR 102 401: “Digital Video Broadcasting (DVB); Transmission to handheld terminals (DVB-H); Validation task force report”.
- ETSI TS 102 584: “Digital Video broadcasting (DVB); DVB-SH Implementation Guidelines”.

OMA BCAST mobile broadcast services system

OMA BCAST is applicable to be used with various broadcast bearers, including the DVB-H and DVB-SH broadcast bearers. Adaptation of OMA mobile broadcast services technology enabler is described in:

- the “BCAST 1.0 Distribution System Adaptation – IPDC over DVB-H” specification³ when the underlying BCAST distribution system is DVB-H.
- the “BCAST 1.1 Distribution System Adaptation – IPDC over DVB-SH” specification⁴ when the underlying BCAST distribution system is DVB-SH.

OMA BCAST 1.0 specifications:

- “Enabler Release Definition for Mobile Broadcast Services”, Open Mobile Alliance, OMA-ERELED-BCAST-V1_0.
- “Mobile Broadcast Services Requirements”, Open Mobile Alliance, OMA-RD-BCAST-V1_0.
- “Mobile Broadcast Services Architecture”, Open Mobile Alliance, OMA-AD-BCAST-V1_0.
- “Mobile Broadcast Services”, Open Mobile Alliance, OMA-TS-BCAST_Services-V1_0.
- “Service Guide for Mobile Broadcast Services”, Open Mobile Alliance, OMA-TS-BCAST_Service_Guide-V1_0.
- “File and Stream Distribution for Mobile Broadcast Services”, Open Mobile Alliance, OMA-TS-BCAST_Distribution-V1_0.
- “Service and Content Protection for Mobile Broadcast Services”, Open Mobile Alliance, OMA-TS-BCAST_SvcCntProtection-V1_0.
- “OMA DRM v2.0 Extensions for Broadcast Support”, Open Mobile Alliance, OMA-TS-DRM_XBS-V1_0.
- “Broadcast Distribution System Adaptation – IPDC over DVB-H”, Open Mobile Alliance, OMA-TS-BCAST_DVB_Adaptation-V1_0.

OMA BCAST 1.1 specifications complementing OMA BCAST 1.0 specifications:

- “BCAST Distribution System Adaptation – IPDC over DVB-SH”, Open Mobile Alliance, draft Version 1.1 – 22 October 2009 (OMA-TS-BCAST_DVBSH_Adaptation-V1_1-20091022-D).

URL of OMA BCAST specifications: <http://www.openmobilealliance.org/>.

NOTE – BR needs to receive the relevant declaration from OMA for the normative reference to their standards in accordance with Resolution ITU-R 9-1.

³ There are also BCAST 1.0 adaptation specifications for telecommunications systems such as 3GPP/MBMS and 3GPP2/BCMCS.

⁴ There are also BCAST 1.1 adaptation specifications for telecommunications systems such as WiMAX Unicast and FLO IP.

Annex 5

Multimedia System “M” (Forward Link Only)

Abstract

The technical characteristics of the Forward Link Only (FLO) physical layer are described in the context of the identified requirements. The result is a new mobile broadcast technology, known as FLO technology.

Standardizing of the Forward Link Only technology has been achieved in the Telecommunications Industry Association (TIA) as Standard TIA-1099 and is further coordinated through the FLO Forum, www.floforum.org.

Other informative references related the Multimedia system “M” performance include:

- TIA-1102: Minimum Performance Specification for Terrestrial Mobile Multimedia Multicast Forward Link Only Devices.
- TIA-1103: Minimum Performance Specification for Terrestrial Mobile Multimedia Multicast Forward Link Only Transmitters.
- TIA-1104: Test Application Protocol for Terrestrial Mobile Multimedia Multicast Forward Link Only Transmitters and Devices.

1 Introduction

The capability of a cellular phone has increased dramatically over the past few years. A device that was originally conceived as a voice-only instrument has steadily evolved into a multi-purpose text and multimedia device.

The advent of video and other rich multimedia services on a cellular phone has been primarily delivered via existing 3G wireless networks. Until recently this delivery was primarily via unicast wireless networks, although the availability of multicast methods within the existing unicast networks is increasing.

The broadcast-multicast mechanisms of these 3G networks are basically added onto the existing unicast physical layer. For simultaneous wide distribution of content, typically beyond a few users per sector, it is generally accepted as economically advantageous to transition to broadcast-multicast delivery.

While the cost reduction that can be achieved by a broadcast mode within a unicast framework can be significant, even greater efficiencies can be achieved by a dedicated broadcast-multicast overlay. Freed from the restrictions imposed by support for unicast operation, a physical layer can be designed specifically for the purpose of delivering multimedia and applications to a large number of users at the lowest possible cost.

The following sections provide the key air interface characteristics of the FLO technology.

2 Requirements for delivery to mobile handhelds

Key requirements for a physical layer design for terrestrial broadcasting of multimedia and data applications for mobile reception include:

- Meeting consumer demands for multimedia services including:
 - Ubiquitous coverage.
 - Local news, weather, and sports.

- National and regional programming.
- Quality of service for all data types.
- Support for streaming audio and video.
- Low-cost, low-power consumption mobile devices.
- Efficient transmission characteristics.
- Cost-effective infrastructure.
- Does not interfere with normal phone functionality.

2.1 Required service types

- *Real-time*: real time multimedia is functionally equivalent to conventional television. The media is consumed as it is delivered.
- *Non-Real-time*: non real time is any type of content that is delivered as a file and stored. This type of delivery allows users to consume media at their convenience. The specific media type of the file is relatively unimportant to the physical layer.
- *IP Datacasting*: datacast supports any application on the handheld devices with an IP interface. The generic nature of IP to some degree limits the performance gains possible by matching the data type to the delivery mechanism, but an IP interface is convenient for the application.
- *Interactive Services*: any of the service types described above may incorporate interactivity that utilizes the unicast capability of a handheld receiver. Some of the more common interactive functions may be supported directly on the device via stored files.

2.2 Quality of service

Each of the services described above have slightly different Quality of service (QoS) requirements. Real-time services require fast channel change and rapid recovery from brief channel outages. File delivery-based services need mechanisms to recover from the impact of similar fading and other channel outages, but are not constrained by rapid acquisition requirements, i.e., quick programme channel changes or recovery from signal loss. The entire file is received and stored prior to consumption. IP-delivered services appear as a combined of the real-time and file delivery types. However, if file delivery is achieved via other non-real time delivery mechanisms, the IP services share much of the characteristics of real time, e.g., an IP delivered “stock ticker” is a real time service with a slightly less stringent time delivery deadline.

2.3 Audio and video support

Audio and video are required media types.

2.4 Functionality, cost, power consumption

The basic mobile device form factor, function, and cost should not be significantly impacted by the addition of the new physical layer. The normal phone functions should not be obstructed by the mobile multimedia functionality.

3 Forward Link Only system architecture

A FLO system is comprised of four sub-systems namely Network Operation Centre (NOC – which consists of a National Operation Centre and one or more Local Operation Centres), FLO transmitters, IMT-2000 networks, and FLO-enabled devices. Figure 9 shown below is a schematic diagram of an example of FLO system architecture.

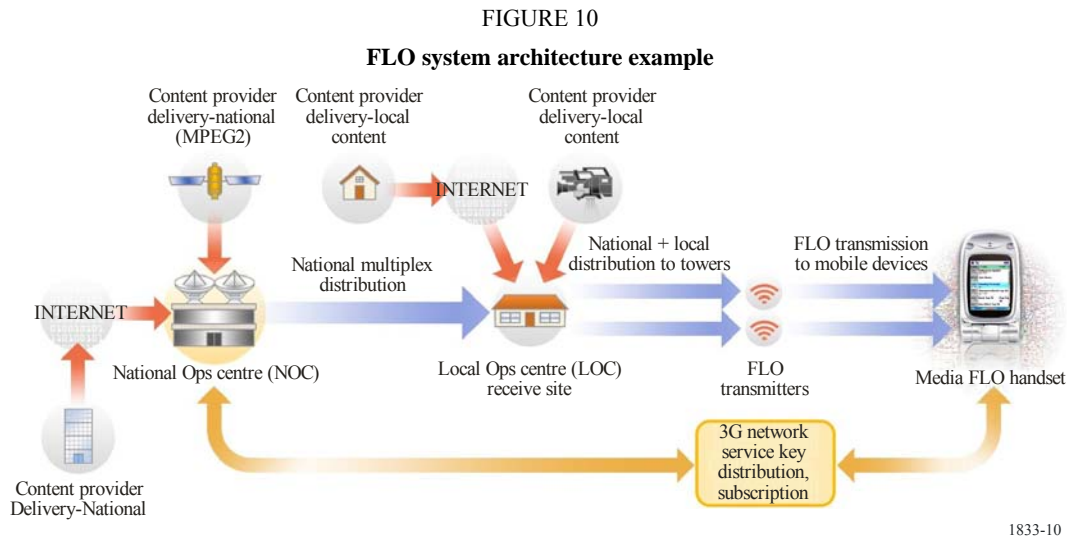

3.1 Network operation centre

The Network Operation Centre consists of a central facility(s) of the FLO network, including the Nation Operation Centre (NOC), also referred to as Wide area Operation Centre (WOC), and one or more Local Operation Centres (LOC). The NOC can include the billing, distribution, and content management infrastructure for the network. The NOC manages various elements of the network and serves as an access point for national and local content providers to distribute wide area content and programme guide information to mobile devices. It also manages user service subscriptions, the delivery of access and encryption keys and provides billing information to cellular operators. The Network Operation Centre may include one or more LOCs to serve as an access point for local content providers to distribute local content to mobile devices in the associated market area.

3.2 FLO transmitters

Each of these transmitters transmits FLO-based waveforms to deliver content to mobile devices.

3.3 IMT-2000 network

The IMT-2000 network supports interactive services and allows mobile devices to communicate with the NOC to facilitate service subscriptions and access key distribution.

3.4 FLO-enabled devices

These devices are capable of receiving FLO waveforms containing content services and programme guide information. FLO-enabled devices are primarily cell phones: multipurpose devices that serve as telephones, address books, Internet portals, gaming consoles, etc. FLO technology strives to optimize power consumption through intelligent integration on the device and optimized delivery over the network.

4 FLO system overview

4.1 Content acquisition and distribution

In a FLO network, content that is representative of a linear real-time channel is received directly from content providers, typically in MPEG-2 format, utilizing off-the-shelf infrastructure equipment. Non real-time content is received by a content server, typically via an IP link. The content is then reformatted into FLO packet streams and redistributed over a single or multiple frequency network (SFN or MFN). The transport mechanism for the distribution of this content to the FLO transmitter may be via satellite, fibre, etc. At one or more locations in the target market, the content is received and the FLO packets are converted to FLO waveforms and radiated out to the devices in the market using FLO transmitters. If any local content is provided, it would have been combined with the wide area content and radiated out as well. Only users of the service may receive the content. The content may be stored on the mobile device for future viewing, in accordance to a service programme guide, or delivered in real-time for live streaming to the user device given a linear feed of content. Content may consist of high quality video (QVGA) and audio (MPEG-4 HE-AAC)⁵ as well as IP data streams. An IMT-2000 cellular network or reverse communication channel is required to provide interactivity and facilitate user authorization to the service.

4.2 Multimedia and data applications services

A reasonable FLO-based programming line-up for 25 frames-per-second QVGA video, with stereo audio, in a single 8 MHz bandwidth frequency allocation, includes 25 to 27 real-time streaming video channels of wide area content including some real-time streaming video channels of local market specific content. The allocation between local and wide area content is flexible and can be varied during the course of the programming day, if desired. In addition to wide area and local content, a large number of IP data channels can be included in the service delivery.

4.3 Power consumption optimization

The FLO technology simultaneously optimizes power consumption, frequency diversity, and time diversity. The Forward Link Only air interface employs time division multiplexing (TDM) to transmit each content stream at specific intervals within the FLO waveform. The mobile device accesses overhead information to determine which time intervals a desired content stream is transmitted. The mobile device receiver circuitry powers up only during the time periods in which the desired content stream is transmitted and is powered down otherwise.

Mobile users can channel surf with the same ease as they would with digital satellite or cable systems at home.

4.4 Wide and local area content

As shown in Fig. 11, FLO supports the coexistence of local and wide area coverage within a single Radio Frequency (RF) channel. When utilizing a SFN, it eliminates the need for complex handoffs for coverage areas. The content that is of common interest to all the receivers in a wide area network is synchronously transmitted by all of the transmitters. Content of regional or local interest can be carried in a specific market.

⁵ High Efficiency AAC (HE AAC) audio profile is specified in “ISO/IEC 14496-3:2001/AMD 1:2003” and is accessible through the ISO/IEC website. The performance of the HE-AAC profile coder is documented in the publicly available formal verification test report WG 11 (MPEG) N 6009.

FIGURE 11
Hierarchy of local and wide area SFNs

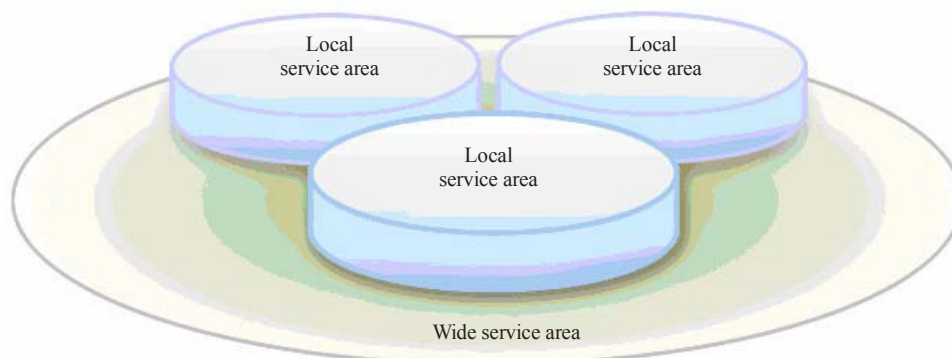

1833-11

4.5 Layered modulation

To provide the best possible quality of service, FLO technology supports the use of layered modulation. With layered modulation, the FLO data stream is divided into a base layer that all users can decode, and an enhancement layer that users with a higher signal-to-noise ratio (SNR) can also decode. The majority of locations will be able to receive both layers of the signal. The base layer has superior coverage as compared to non-layered mode of similar total capacity. The combined use of layered modulation and source coding allows for graceful degradation of service and the ability to receive in locations or speeds that could not otherwise have reception. For the end user, this efficiency means that a FLO network can provide a better coverage with good quality services, especially video, which requires significantly more bandwidth than other multimedia services.

5 FLO air interface

See Standard TIA-1099 at: www.tiaonline.org/standards/catalog: search.

Annex 6

Multimedia System “B” (ATSC Mobile DTV)

Organization

This Annex is organized as follows:

- **Section 1** – Outlines the scope of Annex 6 and provides a general introduction.
- **Section 2** – Lists references and applicable documents.
- **Section 3** – Provides a definition of terms, acronyms, and abbreviations for the ATSC A/153 standard.
- **Section 4** – ATSC-M/H system definition.
- **Section 5** – ATSC-M/H system overview.
- **Section 6** – System configuration signalling.

Scope

This Annex describes the ATSC Mobile DTV system, hereafter referred to as the ATSC mobile/handheld (M/H) system. The M/H system provides mobile/pedestrian/handheld broadcasting services using a portion of the ~19.39 Mbit/s ATSC 8-VSB payload, while the remainder is still available for HD and/or multiple SD television services. The M/H system is a dual-stream system – the ATSC service multiplex for existing digital television services and the M/H service multiplex for one or more mobile, pedestrian and handheld services.

References

At the time of publication, the editions indicated below were valid. All standards are subject to revision, and parties to agreement based on ATSC Standards are encouraged to investigate the possibility of applying the most recent editions of ATSC Standards and of the documents listed below.

Normative references

The following documents contain provisions which, through reference in ATSC A/153 Part 1 (ATSC Mobile DTV Standard, Part 1 – ATSC Mobile Digital Television System), constitute provisions of that standard.

- [1] IEEE/ASTM SI 10-2002, “Use of the International Systems of Units (SI): The Modern Metric System”, Institute of Electrical and Electronics Engineers, New York, N.Y.
- [2] ATSC: “ATSC-Mobile DTV Standard, Part 2 – RF/Transmission System Characteristics”, Doc. A/153 Part 2:2009, Advanced Television Systems Committee, Washington, D.C., 15 October 2009.
- [3] ATSC: “ATSC-Mobile DTV Standard, Part 3 – Service Multiplex and Transport Subsystem Characteristics”, Doc. A/153 Part 3:2009, Advanced Television Systems Committee, Washington, D.C., 15 October 2009.
- [4] ATSC: “ATSC-Mobile DTV Standard, Part 4 – Announcement”, Doc. A/153 Part 4:2009, Advanced Television Systems Committee, Washington, D.C., 15 October 2009.
- [5] ATSC: “ATSC-Mobile DTV Standard, Part 5 – Application Framework”, Doc. A/153 Part 5:2009, Advanced Television Systems Committee, Washington, D.C., 15 October 2009.
- [6] ATSC: “ATSC-Mobile DTV Standard, Part 6 – Service Protection”, Doc. A/153 Part 6:2009, Advanced Television Systems Committee, Washington, D.C., 15 October 2009.
- [7] ATSC: “ATSC-Mobile DTV Standard, Part 7 – AVC and SVC Video System Characteristics”, Doc. A/153 Part 7:2009, Advanced Television Systems Committee, Washington, D.C., 15 October 2009.
- [8] ATSC: “ATSC-Mobile DTV Standard, Part 8 – HE AAC Audio System Characteristics”, Doc. A/153 Part 8:2009, Advanced Television Systems Committee, Washington, D.C., 15 October 2009.

Acronyms and abbreviations

The following acronyms and abbreviations are defined to have the following meanings within the ATSC A/153 standard.

[X]	The greatest integer less than or equal to X
AAC	Advanced Audio Coding
AES	Advanced Encryption Standard
ALC	Asynchronous Layered Coding
AT	ATSC Time

ATSC	Advanced Television Systems Committee
ATSC-M/H	ATSC Mobile/Handheld Standard
AVC	Advanced Video Coding (ITU-T H.264 ISO/IEC 14496-10)
BCRO	Broadcast Rights Object
CRC	Cyclic Redundancy Check
DIMS	Dynamic Interactive Multimedia Scenes
DRM	Digital Rights Management
DTxA	Distributed transmission network adaptor
DTxN	Distributed transmission network
DVB	Digital Video Broadcasting
ESG	Electronic Service Guide
FDT	File Delivery Table
FEC	Forward Error Correction
FIC	Fast Information Channel
FLUTE	File Delivery over Unidirectional Transport (IETF RFC 3926)
FTA	Free-to-Air
GAT-MH	Guide Access Table for ATSC-M/H
HE AAC	High Efficiency Advanced Audio Coding
HE AAC v2	High Efficiency Advanced Audio Coding version 2
IP	Internet Protocol
IPsec	IP Security
ISAN	International Standard Audiovisual Number
LASeR	Lightweight Application Scene Representation
LCT	Layered Coding Transport
LTKM	Long-Term Key Message
M/H	Mobile/pedestrian/handheld
MHE	M/H Encapsulation
N	Number of columns in RS frame payload
NoG	Number of M/H Groups per M/H subframe
NTP	Network Time Protocol
OMA	Open Mobile Alliance
OMA-BCAST	Open Mobile Alliance Broadcast
PCCC	Parallel concatenated convolutional code
PEK	Programme Encryption Key
RI	Rights Issuer
RME	Rich Media Environment

RO	Right Object
ROT	Root Of Trust
RRT-MH	Rating Region Table for ATSC-M/H
RTP	Real-time Transport Protocol
RS	Reed-Solomon
SBR	Spectral Band Replication
SCCC	Serial concatenated convolutional code
SEK	Service Encryption Key
SG	(Electronic) Service Guide
SGN	Starting group number
SLT-MH	Service Labelling Table for ATSC-M/H
SMT-MH	Service Map Table for ATSC-M/H
STKM	Short-Term Key Message
STT-MH	System Time Table for ATSC-M/H
SVC	Scalable Video Coding (Annex G of ITU-T rec. H.264 ISO/IEC 14496-10)
SVG	Scalable Vector Graphics
TCP	Transmission Control Protocol
TEK	Traffic Encryption Key
TNoG	Total Number of M/H Groups including all the M/H Groups belonging to all M/H Parades in one M/H Subframe
TPC	Transmission parameter channel
TS	Transport Stream
UDP	User Datagram Protocol
W3C	World Wide Web Consortium

Terms

The following terms are used within the ATSC A/153 standard.

Broadcast system – The collection of equipment necessary to transmit signals of a specified nature.

Clear-to-air service – A service that is sent unencrypted, and may be received via any suitable receiver with or without a subscription.

Event – A collection of associated media streams that have a common timeline for a defined period. An event is equivalent to the common industry usage of “television program.”

Free-to-air service – A service that is sent encrypted, and for which the keys for decryption are available free of charge.

IP multicast stream – An IP stream in which the destination IP address is in the IP multicast address range.

M/H block – A defined series of contiguous transmitted VSB data segments within an M/H Group, containing M/H data or a combination of main (legacy) and M/H data.

M/H broadcast – The entire M/H portion of a physical transmission channel.

M/H ensemble (or simply “Ensemble”) – A collection of consecutive RS Frames with the same FEC coding, wherein each RS frame encapsulates a specific number of data bytes arranged in datagrams.

M/H frame – Time period that carries main ATSC data and M/H data (encapsulated as MHE packets) equal in duration of exactly 20 VSB data frames (~968 msec.).

M/H group – At the MPEG-2 transport stream level, a collection of 118 consecutive MHE MPEG-2 transport packets delivering M/H service data; also, the corresponding data symbols in the 8-VSB signal after interleaving and trellis coding.

M/H group region (or simply “group region”) – A defined set of M/H Blocks, designated as Region A, B, C, or D.

M/H multiplex – A collection of M/H ensembles in which the IP addresses of the IP streams in the M/H services in the ensembles have been coordinated to avoid any IP address collisions.

A single M/H multiplex may include one or more M/H ensembles.

M/H parade (or simply “parade”) – A collection of M/H groups that have the same M/H FEC parameters. A parade is contained within one M/H frame. Each M/H parade carries one or two M/H ensembles.

M/H service – A package of IP streams transmitted via an M/H Broadcast, which package is composed of a sequence of programmes which can be broadcast.

M/H service signalling channel – A single IP multicast stream incorporated within each M/H Ensemble, delivering M/H service signalling tables that include IP-level M/H service access information.

M/H slot – A portion of an M/H subframe consisting of 156 consecutive MPEG-2 transport packets. A slot may consist solely of all TS-M (main) packets or may consist of 118 M/H packets and 38 TS-M packets. There are 16 M/H slots per M/H subframe. Note: TS-M is transport stream main as defined in A/53 Part3:2007 [9].

M/H subframe – One fifth of an M/H frame; each M/H subframe is equal in duration to 4 VSB data frames (8 VSB data fields).

M/H TP – The term “M/H Transport Packet (M/H TP)” is used to designate a row of an RS frame with two bytes header included. Thus, each RS frame is composed of 187 M/H TPs.

Number of groups (NoG) – The number of M/H groups per M/H subframe for a particular Ensemble.

Parade repetition cycle – A specification of the frequency of transmission of a parade carrying a particular ensemble. The Parade containing a particular Ensemble is transmitted in one M/H frame per *PRC* M/H frames; e.g., *PRC* = 3 implies transmission in one M/H frame out of every three M/H frames.

Primary DIMS stream – A stream which defines the complete scene tree; i.e., in which all random access points are, or build, a complete DIMS scene.

Primary ensemble – An ensemble to be transmitted through a primary RS frame of a parade.

Protected content – Media stream that is protected according to the requirements of A/153 Part 6.

Reference receiver – A physical embodiment of hardware, operating system, and native applications of the manufacturer’s choice, which collectively constitute a receiver for which specified transmissions are intended.

Regional M/H service – A service which appears in two or more MH broadcasts. Typically this is a service transmitted by more than one broadcast facility.

RI object – A binary coded registration layer message or LTKM layer message.

RI Stream – A stream of UDP packets with the common source and destination IP addresses and UDP port, containing RI objects.

Rights Issuer URI – A string that identifies the rights issuer issuing RI objects and service encryption keys (SEKs). Rights issuer URI type is any URI.

Rights object – A collection of permissions and other attributes which are linked to protected content.

RS Frame – Two-dimensional data frame by means of which an M/H ensemble is RS CRC encoded. RS frames are the output of the M/H physical layer subsystem. Generally, one RS frame contains 187 rows of N bytes each, where the value of N is determined by the transmission mode of M/H physical layer subsystem, and carries data for one M/H ensemble. RS frames are defined in detail in Part 2.

RS frame portion length – The number of SCCC payload bytes per group.

Secondary ensemble – An ensemble to be transmitted through a secondary RS frame of a parade. Depending on RS frame mode, a parade may or may not have the secondary ensemble and associated secondary RS frame.

Starting group number – The group number assigned to the first group in a parade, which determines placement of the parade into a particular series of M/H Slots.

Total Number of Groups – The number of groups per M/H subframe including all M/H ensembles present in the subframe.

ATSC-M/H system definition

Documentation of the ATSC-M/H system has been organized into self-contained parts. The parts referenced below establish the characteristics of the subsystems necessary to accommodate the services envisioned:

1. The RF and transmission system of the ATSC-M/H system is defined in A/153 Part 2 [2].
2. The service multiplex and transport subsystem characteristics of the ATSC-M/H system is defined in A/153 Part 3 [3].
3. The announcement method of the ATSC-M/H system is defined in A/153 Part 4 [4].
4. The presentation framework of the ATSC-M/H system is defined in A/153 Part 5 [5].
5. An ATSC-M/H service may optionally utilize service protection. When service protection is used, it is defined in the provisions of A/153 Part 6 [6].
6. Video coding in the ATSC-M/H system is defined in A/153 Part 7 [7].
7. Audio coding in the ATSC-M/H system is defined in A/153 Part 8 [8].

The parts listed above contain the required elements and some optional elements. Additional ATSC standards may define other required and/or optional elements.

ATSC-M/H system overview

The ATSC mobile/handheld service (M/H) shares the same RF channel as a standard ATSC broadcast service described in ATSC A/53 [9], also known as the “main service” (or more precisely TS-M). M/H is enabled by using a portion of the total available ~19.4 Mbit/s bandwidth and utilizing delivery over IP transport. The overall ATSC broadcast system including standard (Main) and M/H systems is illustrated in Fig. 12.

FIGURE 12
 ATSC broadcast system with TS main and M/H services

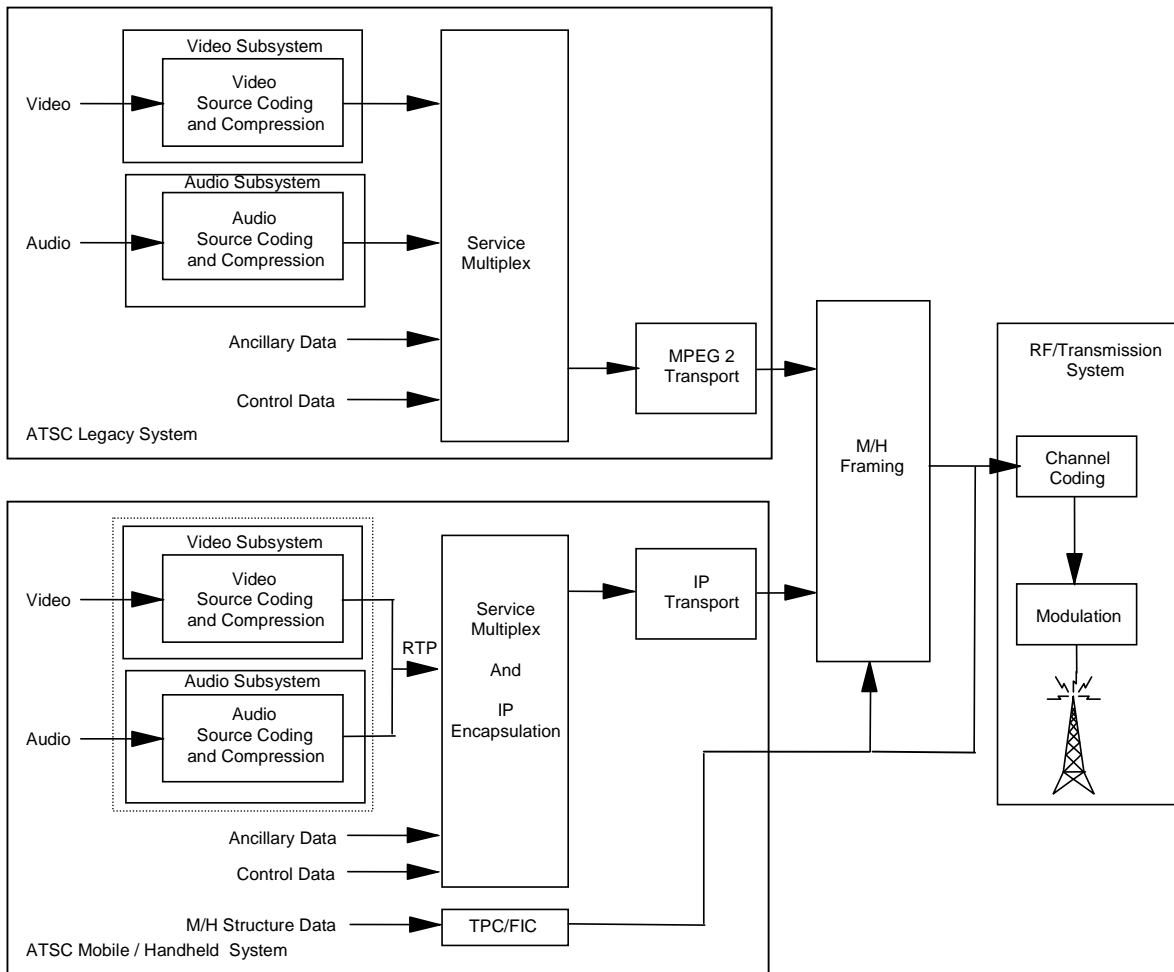

1833-12

Central to the M/H system are additions to the physical layer of the ATSC transmission system that are easily decodable under high Doppler rate conditions. Additional training sequences and additional forward error correction (FEC) assist reception of the enhanced stream(s).

Consideration has also been given to the many system details that make such a signal compatible with legacy ATSC receivers, particularly audio decoder buffer constraints; but also such constraints as MPEG transport packet header standards, requirements for legacy PSIP carriage, etc. These changes do not alter the emitted spectral characteristics.

The ATSC-M/H system is separated into logical functional units corresponding to the protocol stack is illustrated in Fig. 13.

FIGURE 13
ATSC-M/H system protocol stack

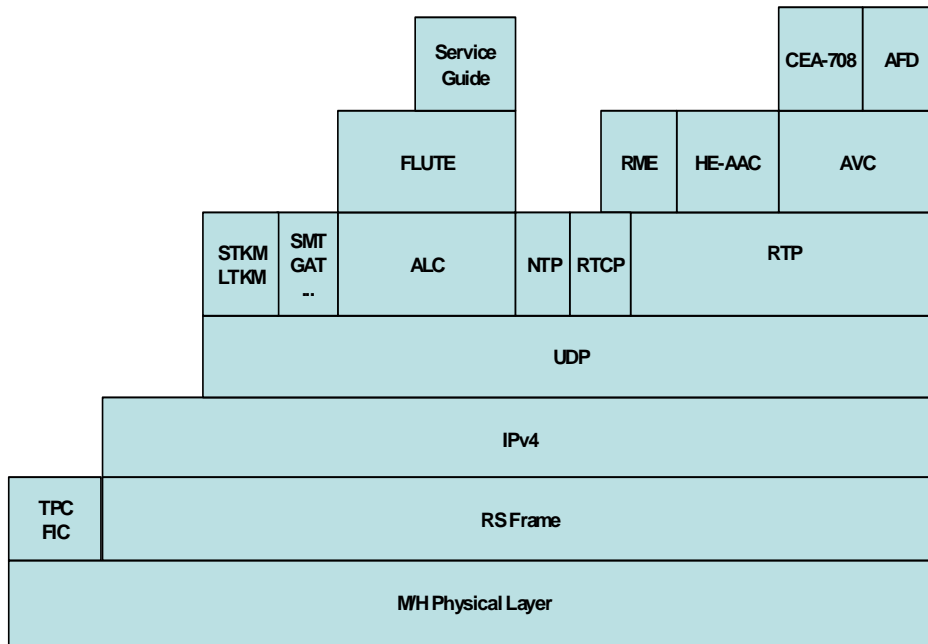

1833-13

Description of the A/153 standard's parts

The following sections provide an over view of the contents of the parts that make up the ATSC M/H standard.

Part 1 – RF/transmission

M/H data is partitioned into ensembles, each of which contains one or more services. Each ensemble uses an independent RS frame (an FEC structure) and, furthermore, each ensemble may be coded to a different level of error protection depending on the application. M/H encoding includes FEC at both the packet and trellis levels, plus the insertion of long and regularly spaced training sequences into the M/H data. Robust and reliable control data is also inserted for use by M/H receivers. The M/H system provides bursted transmission of the M/H data, which allows the M/H receiver to cycle power in the tuner and demodulator for energy saving.

Part 2 – Service multiplex and transport subsystem

The M/H data are transmitted within the 8-VSB signal on a time-slice basis, which facilitates burst-mode reception of just selected portions of the M/H data by an M/H receiver. Each M/H frame time interval is divided into 5 sub-intervals of equal length, called M/H subframes. Each M/H subframe is in turn divided into 4 sub-divisions of length 48.4 ms, the time it takes to transmit one VSB frame. These VSB frame time intervals are in turn divided into 4 M/H slots each (for a total of 16 M/H slots in each M/H subframe).

The M/H data to be transmitted is packaged into a set of consecutive RS frames, where this set of RS frames logically forms an M/H ensemble. The data from each RS frame to be transmitted during a single M/H frame is split up into chunks called M/H groups, and the M/H groups are organized into M/H parades. Each M/H parade comprises the M/H groups from either a single RS frame or from both a primary RS frame and a secondary RS frame. The number of M/H groups belonging to an M/H parade is always a multiple of 5, and the M/H groups in the M/H parade go into M/H slots that are equally divided among the M/H subframes of the M/H frame.

The RS frame is the basic data delivery unit, into which the datagrams in some defined structure are encapsulated (IP is the means defined currently). While an M/H parade always is associated with a primary RS frame, it also may be associated with a secondary RS frame. The number of RS frames and the size of each RS frame are determined by the transmission mode of the M/H physical layer subsystem. Typically, the size of the primary RS frame is bigger than the size of secondary RS frame associated with the same M/H parade.

The fast information channel (FIC) is a separate data channel from the data channel delivered through RS frames. The main purpose of the FIC is to efficiently deliver essential information for rapid M/H Service acquisition. This information primarily includes binding information between M/H services and the M/H ensembles carrying them, plus version information for the M/H service signalling channel of each M/H ensemble.

In ATSC-M/H, an “M/H service” is similar in general concept to a virtual channel as defined in ATSC A/65 [10]. An M/H service is currently defined to be a package of IP streams transmitted through M/H Multiplex, which forms a sequence of programmes under the control of a broadcaster which can be broadcast as part of a schedule. Typical examples of M/H services include TV services and audio services. Collections of M/H services are structured into M/H ensembles, each of which consists of a set of successive RS frames.

NOTE 1 – The system design is independent of the choice of the protocol at this layer. MPEG-2 Transport Stream packets were supported in the original submission, IP was selected as the transport means for this release and others are supportable in the future.

In general, there are two types of files that might be delivered using the methods described in the ATSC A/153 standard (primarily based on FLUTE). The first of these is content files, such as music or video files. The second type of file that may be transmitted is the service guide fragments. In either case, the delivery mechanisms are the same and it is up to the terminal to resolve the purpose of the files.

Part 3 – Announcement

In an M/H system, the services available from a broadcaster (or another broadcaster) are announced via the announcement subsystem. Services are announced using a service guide. A service guide is a special M/H service that is declared in the service signalling subsystem. An M/H receiver determines available service guides by reading the guide access table for M/H (GAT-MH). This table lists the service guides present in the M/H broadcast, gives information about the service provider for each guide, and gives access information for each guide.

The ATSC-M/H service guide is an OMA BCAST service guide, with constraints and extensions as specified in the ATSC A/153 standard. A service guide is delivered using one or more IP streams. The main stream delivers the announcement channel, and zero or more streams are used to deliver the guide data. If separate streams are not provided, guide data is carried in the announcement channel stream.

Part 4 – Application framework

The primary objective for the M/H platform is to deliver a set of audio and/or video services from a transmission site to mobile or portable devices. The application framework enables the broadcaster of the audio-visual service to author and insert supplemental content to define and control various additional elements to be used in conjunction with the M/H audiovisual service. It enables definition of auxiliary (graphical) components, layout for the service, transitions between layouts and composition of audiovisual components with auxiliary data components.

Furthermore, it enables the broadcaster to send remote events to modify the presentation and to control the presentation timeline. The application framework further enables coherent rendering of the service and its layout on a variety of device classes and platforms, rendering of action buttons and input fields, and event handling and scripting associated with such buttons and fields.

Part 5 – Service protection

Service protection refers to the protection of content, be that files or streams, during its delivery to a receiver. Service protection is an access control mechanism intended for subscription management. It establishes no controls on content after delivery to the receiver.

The ATSC-M/H service protection system is based on the OMA BCAST DRM profile. It consists of the following components:

- Key provisioning.
- Layer 1 registration.
- Long-term key message (LTKM), including the use of broadcast rights objects (BCROs) to deliver LTKMs.
- Short-term key messages (STKM).
- Traffic encryption.

The system relies on the following encryption standards:

- Advanced encryption standard (AES).
- Secure Internet Protocol (IPsec).
- Traffic encryption key (TEK).

In the OMA BCAST DRM profile there are two modes for service protection – interactive and broadcast-only mode. In interactive mode, the receiver supports an interaction channel to communicate with a service provider, in order to receive service and/or content protection rights. In broadcast-only mode, the receiver does not use an interaction channel to communicate with a service provider. Requests are made by the user through some out-of-band mechanism to the service provider, such as calling a service provider phone number or accessing the service provider website.

Part 6 – AVC and SVC video system

The M/H system uses MPEG-4 Part 10 AVC and SVC video coding as described in Recommendation ITU-T H.264 | ISO/IEC 14496-10, with certain constraints.

Part 7 – HE AAC audio system

The M/H system uses MPEG-4 Part 3 HE AAC v2 audio coding as described in ISO/IEC 14496-3 (with Amendment 2), with certain constraints. HE AAC v2 is used to code mono or stereo audio and is a combination of three specific audio coding tools, MPEG-4 AAC, spectral band replication (SBR) and parametric stereo (PS).

Appendix 1 (Informative)

Additional information on the telecom network based Multimedia Broadcast/Multicast Services

There are telecommunication systems not explicitly dedicated to broadcasting services, such as Multimedia Broadcast/Multicast Services (MBMS) as shown in this Appendix, that fulfil the requirements for interoperability between mobile telecommunication services and interactive digital broadcasting services. The MBMS system is intended to work within services other than broadcasting.

MBMS key characteristics

MBMS standards (see Table 5) specify broadcast/multimedia radio bearers; the MBMS system contains the following features:

- The MBMS routing of information/data flows in a core network.
- The radio bearers for mobile A/V multimedia services for point-to-multipoint radio transmission.
- A set of functions that control the MBMS delivery.

Key aspects of the MBMS system are summarized in the following list:

- Mobile A/V multimedia services transmission capabilities in a network infrastructure
 - Allows over-the-air mobile A/V multimedia services (allowing for mobile A/V multimedia services without the need for reception acknowledgement).
 - Reuses IP multicast framework.
- Supports streaming
 - Enables mobile A/V multimedia service streaming.
 - Reuses already specified protocols for media delivery (RTP).
 - FEC protection of single flows and entire channel bundles.
 - Reception reporting is supported.
- Supports download
 - Enables information/data push services.
 - Uses FLUTE as File-Delivery Protocol (RFC 3926).
 - Forward Error Correction (FEC) to protect entire files.
 - Repair function to increase reliability of file delivery.
 - Reception Acknowledgment is supported.

One important aspect of MBMS is flexibility. It should be set to use only a portion of a carrier, leaving the rest transmission capacity for other information based and data services, but it is certainly possible to devote a carrier frequency entirely for MBMS mobile A/V multimedia service radio bearers. The MBMS comprises a variable number of MBMS radio bearers. Moreover, each radio bearer can have a different bit rate, up to 256 kbit/s. The performance of MBMS is described in [5] and in Table 4.

The geographical area in which a particular MBMS service is provided is called a Service Area. Service Areas can be as large as an entire country or as small a single radio site with a limited coverage of a few 100 m or even smaller if desired. Each radio transmission site can deliver different services, even if the same radio channel of 5 MHz is used for all transmission sites. Due to the possibility for small in size coverage areas, mobile A/V multimedia services can easily be customized to deliver different content with very fine granularity in different areas of the network. Figure 11 gives an example of MBMS service area configurations and relations between MBMS bearer service and MBMS service areas.

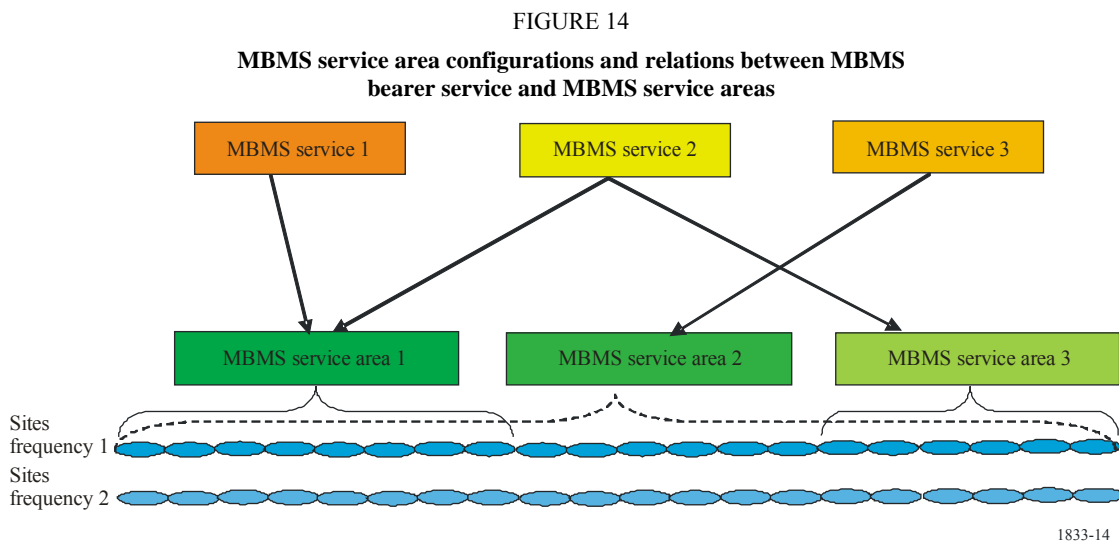

More precisely, there is the following flexibility in the service to area mapping:

- One MBMS service area can consist of 1..x transmission sites(s).
- One MBMS bearer service can be configured for 1..y MBMS service area(s).
- One MBMS service area can be allocated to 0..z MBMS bearer service(s).

Independently of the Service Areas, an unlimited number of special interest streaming mobile A/V multimedia service programmes that have a low penetration of users can be offered.

Further details about the characteristics and performance of MBMS can be found in Table 4.

MBMS requirements

According to the specification, the following high-level requirements apply to the MBMS [2]:

- MBMS architecture enables the efficient usage of radio-network and core-network resources, with the main focus on the radio interface efficiency. Specifically, multiple users should be able to share common resources when receiving identical traffic.
- The MBMS architecture supports common features for MBMS multicast and broadcast modes.
- The MBMS architecture does not describe the means by which the Broadcast Multicast Service Centre (BM-SC) obtains the service data. The data source may be external or internal to the PLMN, e.g., content servers in the fixed IP network. Any UE attached to the PLMN MBMS shall support both IP multicast and IP unicast sources.
- MBMS architecture may reuse, to the extent possible, existing core network components and protocol elements thus minimizing the complexity to infrastructure and providing a solution based on known concepts.

- MBMS is a multimedia/broadcast point-to-multipoint bearer service for IP packets in the packet switched (PS) domain.
- MBMS is interoperable with IETF IP Multicast.
- MBMS supports IETF IP Multicast addressing.
- MBMS service areas are defined per individual service with a per transmission site granularity.
- MBMS is not supported in the circuit switched (CS) domain.
- Charging data shall be provided per subscriber for MBMS multicast mode.
- The MBMS bearer service concept contains the decision making process for selection of multimedia/broadcast point-to-point or point-to-multipoint configurations.
- The architecture is able to provide home network MBMS multicast services to users when roaming outside their home network as subject to inter-operator agreements.

The MBMS Broadcast Multicast Service Centre

The MBMS network architecture and nodes affected by the introduction of MBMS are shown in Fig. 15.

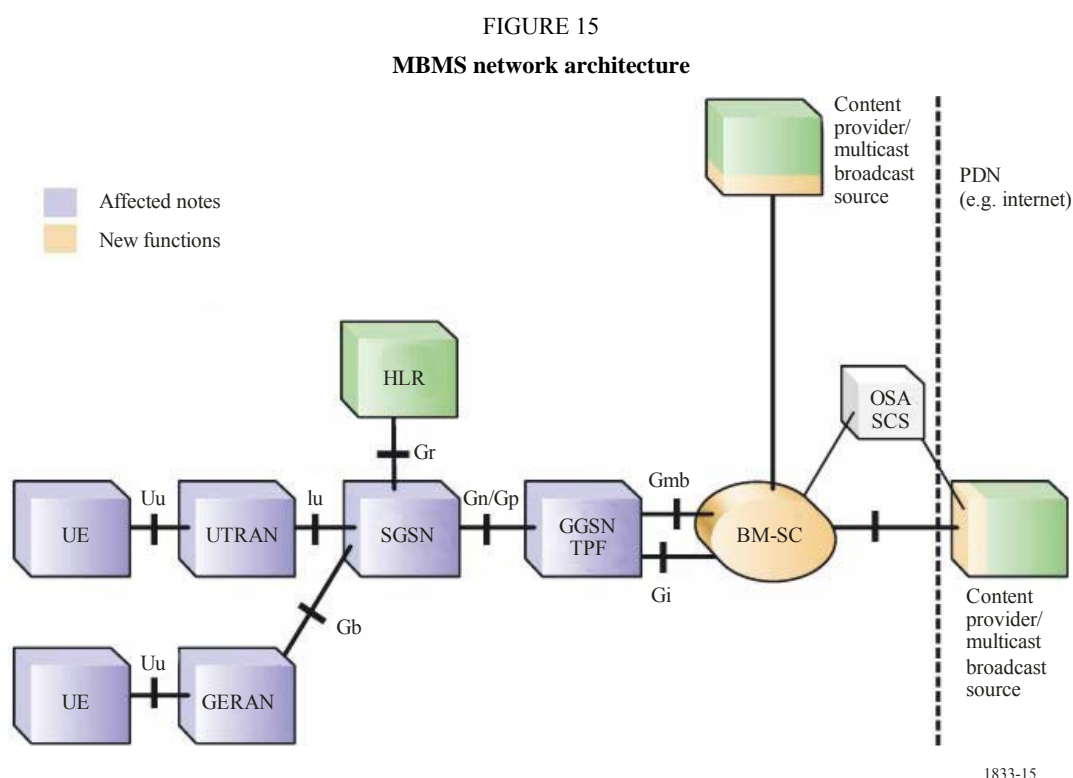

The Broadcast Multicast Service Centre (BM-SC) (see Fig. 15) includes functions for MBMS user service provisioning and delivery. It may serve as an entry point for content provider MBMS transmissions, used to authorize and initiate MBMS Bearer Services within the PLMN, and can be used to schedule and deliver MBMS transmission.

The BM-SC is a functional entity that must exist for each MBMS User Service. According to the specifications, the following requirements apply to BM-SC [1]:

- The BM-SC is able to authenticate third party content providers, providing content for MBMS transmission. Third-party content provider may wish to initiate an MBMS mobile A/V multimedia service transmission. In such case, the BM-SC is able to authorize content provider to transmit data over MBMS bearer service depending on the policy.
- The BM-SC is able to deliver media and session description by means of service announcements using IETF specified protocols over MBMS multicast and broadcast bearer services.
- The BM-SC is able to accept content from external sources and transmit it using error resilient schemes (e.g., specialized MBMS code).
- The BM-SC might be used to schedule MBMS session transmissions, retrieve content from external sources and provide this content using MBMS bearer services.
- The BM-SC is able to schedule MBMS session retransmissions and label each MBMS session with an MBMS session identifier to allow the UE to distinguish the MBMS session retransmissions. These retransmissions are transparent to the RAN and MBMS user service.

MBMS user equipment handheld terminal capabilities

To be able to support/ receive the MBMS services the user equipment (UE) has the following requirements [13]:

- The UE supports functions for the activation/deactivation of the MBMS bearer services.
- Once a particular MBMS bearer service is activated, no further explicit user request is required to receive MBMS data although the user may be notified that data transfer is about to start.
- It is possible for UE to receive MBMS when the terminal is attached.
- It shall be possible for UE to receive MBMS mobile A/V multimedia services in parallel to other services and signalling (e.g., paging, voice call).
- The UE, depending on terminal capabilities, is to receive MBMS user service announcements, paging information (non MBMS specific) and support simultaneous services (for example the user can originate or receive a call or send and receive messages whilst receiving MBMS video content). Reception of this paging or announcements may however, create losses in the MBMS mobile A/V multimedia service reception. The MBMS user service should be able to cope with such losses.
- Depending upon terminal capability, UE may be able to store MBMS information and data.
- The MBMS Session Identifier contained in the notification to the UE enables the UE to decide whether it needs to ignore the forthcoming transmission of MBMS session (e.g., because the UE has already received this MBMS session).
- When the UE is already receiving mobile A/V multimedia services of an MBMS, it is possible for the UE to be notified about a forthcoming and potentially about an on-going data transfer from other MBMS services.

MBMS service and Application types

MBMS can be used as an enabler for various mobile A/V multimedia services. There are two types of MBMS User Service considered within this specification [3], [4].

- **Streaming services:** A continuous data flow providing a stream of continuous media (i.e., audio and video) is a basic MBMS User Service.

- **File download services:** This service delivers binary data (file data) over an MBMS bearer. The most important functionality for this service is reliability. In other words, it is necessary that the user receive all the data sent in order to experience the service.

MBMS radio bearer implementation

The CDMA MBMS mobile A/V multimedia service radio bearer implementation defines three logical channels and one physical channel. The logical channels are:

- MBMS point-to-multipoint control channel (MCCH), which contains details concerning on-going and upcoming MBMS mobile A/V multimedia service sessions;
- MBMS point-to-multipoint scheduling channel (MSCH), which provides information on data scheduled on MTCH;
- MBMS point-to-multipoint traffic channel (MTCH), which carries the actual MBMS application data.
- The physical channel is the MBMS notification indicator channel (MICH) by which the network informs the MBMS user equipment (UE), handheld terminals, of available MBMS information on MCCH.

Two interleaving depths (TTI) are used in MBMS for the MTCH: 40 and 80 ms. The selection of a long interleaving depth (TTI) provides greater diversity in the time domain by spreading user data over the fading variations. This, in turn, yields improved MBMS capacity.

TABLE 4

Performance of Multimedia Broadcast/Multicast Services for mobile reception

User requirements	MBMS
High quality multimedia for handheld receivers	
1. Media type with quality characteristics <ul style="list-style-type: none"> – Resolution – Frame rate – Bit rate 	<ul style="list-style-type: none"> – QCIF (176 × 144) – SQVGA (160 × 120) – 15 fps – QVGA@30 fps possible if supported by terminal Speech: <ul style="list-style-type: none"> – Stereo and mono <ul style="list-style-type: none"> – 6-24 kbit/s Audio <ul style="list-style-type: none"> – Stereo and mono <ul style="list-style-type: none"> – 24-48 kbit/s – higher bitrates only limited by terminal capabilities Other <ul style="list-style-type: none"> – Synthetic audio (SP-MIDI) – Still images – Bitmap graphics – Text

TABLE 4 (continued)

User requirements	MBMS
2. Monomedia coding: <ul style="list-style-type: none"> – Video – Audio – Others 	Video: <ul style="list-style-type: none"> H.264 (AVC) Baseline Profile Level 1b decoder Speech: <ul style="list-style-type: none"> – AMR NB – AMR WB Audio: <ul style="list-style-type: none"> – Extended AMR-WB – HE AAC Still images: <ul style="list-style-type: none"> ISO/IEC JPEG Bitmap graphics: <ul style="list-style-type: none"> – GIF87a, GIF89a, PNG Vector graphics: <ul style="list-style-type: none"> – SVG Tiny 1.2 and ECMAScript Text <ul style="list-style-type: none"> – XHTML Mobile Profile in formats UTF-8, UCS-2
Flexible configuration of services: <ul style="list-style-type: none"> – Audio/video – Ancillary and auxiliary data 	<ul style="list-style-type: none"> – Real-time audio and video – Digital radio – Scheduled content and file download – Service Discovery/Announcement (EPG): Broadcast Distribution or interactive retrieval – Subtitling (synchronized hypertext with A/V via MPEG-4 BIFS) – 6 parallel real-time broadcast streaming services of 128 kbit/s each per 5 MHz radio channel. 12 services possible with advanced receiver (antenna diversity) – An unlimited number of special interest streaming services that have a low penetration of users can be offered – National/local/hotspot local broadcast. Each radio site can broadcast different services, even if the same radio channel of 5 MHz is used for all sites – Multicast allows limiting the transmission to areas, which are known to host interested users
Conditional access	Supported
International roaming	Supported (home services accessible from visited/foreign networks)
Seamless portability access	Supported; user equipment (UE) handheld terminals moving from the home mobile multimedia/broadcast network to a visiting network is able to access multimedia/broadcast services provided by the visited network, using the authorization of the original home service provider
Fast discovery and selection of content and services	Electronic Programme Guide support for discovery and selection of services. Service Announcement Information (EPG) may be broadcast periodically, but can also be requested by user terminal and is delivered immediately

TABLE 4 (end)

User requirements	MBMS
Stable and reliable reception and QoS control in various types of receiving environments	Use of the following techniques: <ul style="list-style-type: none"> – CDMA – Time domain interleaving of up to 80 ms on physical layer – Application layer FEC enables virtually unlimited time diversity, only bound by channel switching time – Code rate of application layer FEC is freely selectable – Transmit power can be adjusted per programme stream to achieve desired coverage and QoS – (Soft) combining of signals from neighbouring sites always possible Provides <ul style="list-style-type: none"> – Variable QoS and robustness – High mobility up to 250 km/h
Network configuration	SFN is the default configuration. The geographical area in which a particular MBMS service is provided is called a service area. Service Areas can be as large as an entire country or as small a single radio site with a limited coverage of few 100 m or even smaller if desired. SFN is used even across adjacent service areas
Lower power consumption in comparison to stationary reception Mechanisms to achieve power consumption savings	MBMS system is designed for mobile reception and therefore for battery efficiency from the beginning
Provision of interactive content and applications	Support system for integrated interactivity with mobile multimedia telecommunication networks. Interactivity content and applications use: <ul style="list-style-type: none"> – References to interactive services available on the devices or remotely located
Interoperability with mobile telecommunication networks	Support for mobile multimedia over mobile telecommunication networks
Spectrum efficiency (bit/s/Hz)	The efficiency for MBMS broadcast mode given below is equal to the network spectral efficiencies. The efficiencies take into account that a single carrier frequency of 5 MHz is sufficient to provide full area coverage. For the lower end of the given spectrum efficiency range it is possible to provide different services in adjacent sites. 0.15-0.4 bit/s/Hz for broadcast mode up to 2.88 bit/s/Hz with 16-QAM code rate 1/1 for users in optimal reception conditions
Efficient transport mechanism (not highlighted in the User requirements section)	Standard IP based technologies fully deployed: RTP for streaming, FLUTE/ALC for file download delivery. Application layer FEC supported for file and stream delivery

TABLE 5
Specifications of MBMS for mobile reception

		MBMS
Bandwidth		5 MHz
Physical Layer		ETSI TS 125 346 TR 25.803
Encapsulation		PDCP and GTP (ETSI TS 125 323 and ETSI TS 129 060)
Data Transmission Mechanism		IETF RFC 3550 (RTP) IETF RFC 3926 (FLUTE) IETF RFC 768 (UDP/IP) IETF RFC 761 (IPv4) IETF RFC 2460 (IP v6)
Multimedia Content Format		ETSI TS 126 244 (3GP)
Mono-media Coding	Speech	AMR Narrowband: ETSI TS 126 071, ETSI TS 126 090, ETSI TS 126 073, ETSI TS 126 074 AMR Wideband: 3GPP TS 26.171, ETSI TS 126 190, ETSI TS 126 173, ETSI TS 126 204
	Audio Coding	Enhanced aacPlus: ETSI TS 126 401, ETSI TS 126 410, ETSI TS 126 411 Extended AMR-WB: ETSI TS 126 290 ETSI TS 126 304 ETSI TS 126 273
	Video Coding	ITU-T Rec. H.264 and ISO/IEC 14496-10 AVC
	Others	Synthetic Audio: Scalable Polyphony MIDI Specification Version 1.0, Scalable Polyphony MIDI Device 5-to-24 Note Profile for 3GPP Version 1.0 Vector Graphics: W3C Working Draft 27 October 2004: "Scalable Vector Graphics (SVG) 1.2" W3C Working Draft 13 August 2004: "Mobile SVG Profile: SVG Tiny, Version 1.2" Standard ECMA-327 (June 2001): "ECMAScript 3rd Edition Compact Profile" Still images: ISO/IEC JPEG Bitmap graphics: GIF87a, GIF89a, PNG

Informative references:

- [1] ETSI TS 123.246 (3GPP TS 23.246), “MBMS Architecture and Functional description”.
- [2] ETSI TS 125.346 (3GPP TS 25.346) Introduction of the Multimedia Broadcast/Multicast Service (MBMS) in the Radio Access Network (RAN); Stage 2.
- [3] ETSI TS 122.246 (3GPP TS 22.246), “MBMS User Services (stage 1)”.
- [4] ETSI TS 126.346 (3GPP TS 26.346), “Multimedia Broadcast/Multicast Service (MBMS); Protocols and codecs”.
- [5] 3GPP TR 25.803, “S-CCPCH performance for MBMS”.

ETSI is a recognized Standards Developing Organization and partner in 3GPP (3rd Generation Partnership Project), ETSI publishes the 3GPP specifications at a certain stage of the standards developing process; MBMS is specified by the 3GPP.

Appendix 2 (Informative)

Emission and reception characteristics for Multimedia Systems “A”, “B”, “C”, “E”, “F”, “H”, “I” and “M”

Administrations who intend to introduce a Multimedia System for mobile reception by handheld receivers may select the physical layer part from Recommendations ITU-R BT.1306, ITU-R BS.1114, ITU-R BS.1547, ITU-R BO.1130, ETSI EN 302 304, ETSI EN 302 583, TIA-1099 and ATSC A/153 based on the transmission parameters in Table 6.

Table 7 provides information about the applicability and the deployment of Multimedia broadcasting systems for mobile reception by handheld receivers in a real environment.

TABLE 6

Transmission parameters for multimedia systems

	Parameters	Multimedia System "A"	Multimedia System "B"	Multimedia System "C"	Multimedia System "E"	Multimedia System "F"	Multimedia System "H"	Multimedia System "T"	Multimedia System "M"
	References	Rec. ITU-R BS.1114 System A and TTAK.KO-07.0070/R1	Rec. ITU-R BT.1306 System A ATSC Standard A/153	Rec. ITU-R BT.1306 System C	Rec. ITU-R BO.1130 System E and Rec. ITU-R BS.1547 System E	Rec. ITU-R BT.1306 System C and Rec. ITU-R BS.1114 System F	ETSI EN 302 304 and TR 102 377	ETSI EN 302 583 and TS 102 584	TIA-1099
1	Channel bandwidths ⁽¹⁾	a) 1.712 MHz	6 MHz	1/14 of a) 6 MHz b) 7 MHz c) 8 MHz	25 MHz	1/14 × n of a) 6 MHz b) 7 MHz c) 8 MHz n ≥ 1 (*1)	a) 5 MHz b) 6 MHz c) 7 MHz d) 8 MHz	OFDM (SH-A) and TDM (SH-B): a) 1.7 MHz b) 5 MHz c) 6 MHz d) 7 MHz e) 8 MHz	a) 5 MHz b) 6 MHz c) 7 MHz d) 8 MHz
2	Used bandwidth	a) 1.536 MHz	5.38 MHz Nyquist; 6 MHz total	a) 432.5 kHz (Mode 1), 430.5 kHz (Mode 2), 429.6 kHz (Mode 3) b) 504.6 kHz (Mode 1), 502.4 kHz (Mode 2), 501.2 kHz (Mode 3) c) 576.7 kHz (Mode 1), 574.1 kHz (Mode 2), 572.8 kHz (Mode 3)	19 MHz (occupied band for typical satellite system)	"Subcarrier spacing" (see Item 4) + 1/14 × n × a) 6 MHz b) 7 MHz c) 8 MHz n ≥ 1 (*1)	a) 4.75 MHz b) 5.71 MHz c) 6.66 MHz d) 7.61 MHz	OFDM: a) 1.52 MHz b) 4.75 MHz c) 5.71 MHz d) 6.66 MHz e) 7.61 MHz TDM: a) 1.368 MHz b) 4.27 MHz c) 5.13 MHz d) 5.18 MHz e) 6.838 MHz	a) 4.52 MHz b) 5.42 MHz c) 6.32 MHz d) 7.23 MHz

TABLE 6 (continued)

	Parameters	Multimedia System "A"	Multimedia System "B"	Multimedia System "C"	Multimedia System "E"	Multimedia System "F"	Multimedia System "H"	Multimedia System "I"	Multimedia System "M"
3	Number of subcarriers or segments	192 384 768 1 536	1	1	At most 64 CDM channels	n >= 1 (*1) The number of segments is determined by the available bandwidth	1 705 (2k mode) 3 409 (4k mode) 6 817 (8k mode)	OFDM: 853 (1k mode) 1 705 (2k mode) 3 409 (4k mode) 6 817 (8k mode)	4 000 (out of 4k)
4	Subcarrier spacing	a) 8 kHz b) 4 kHz c) 2 kHz d) 1 kHz	Not applicable	a) 3.968 kHz (Mode 1), 1.984 kHz (Mode 2), 0.992 kHz (Mode 3) b) 4.629 kHz (Mode 1), 2.314 kHz (Mode 2), 1.157 kHz (Mode 3) c) 5.291 kHz (Mode 1), 2.645 kHz (Mode 2), 1.322 kHz (Mode 3)	Not applicable	a) 3.968 kHz (Mode 1), 1.984 kHz (Mode 2), 0.992 kHz (Mode 3) b) 4.629 kHz (Mode 1), 2.314 kHz (Mode 2), 1.157 kHz (Mode 3) c) 5.291 kHz (Mode 1), 2.645 kHz (Mode 2), 1.322 kHz (Mode 3)	a) 2 790.179 Hz (2k), 1 395.089 Hz (4k), 697.545 Hz (8k) b) 3 348.21 Hz (2k), 1 674.11 Hz (4k), 837.05 Hz (8k) c) 3 906 Hz (2k), 1 953 Hz (4k), 976 Hz (8k) d) 4 464 Hz (2k), 2 232 Hz (4k), 1 116 Hz (8k)	OFDM: a) 1 786 kHz (1k) b) 5 580.322 Hz (1k), 2 790.179 Hz (2k), 1 395.089 Hz (4k), 697.545 Hz (8k) c) 6 696.42 Hz (1k), 3 348.21 Hz (2k), 1 674.11 Hz (4k), 837.05 Hz (8k) d) 7 812 Hz (1k), 3 906 Hz (2k), 1 953 Hz (4k), 976 Hz (8k) e) 8 929 Hz (1k), 4 464 Hz (2k), 2 232 Hz (4k), 1 116 Hz (8k)	a) 1.1292 kHz b) 1.355 kHz c) 1.5808 kHz d) 1.8066 kHz

TABLE 6 (continued)

	Parameters	Multimedia System "A"	Multimedia System "B"	Multimedia System "C"	Multimedia System "E"	Multimedia System "F"	Multimedia System "H"	Multimedia System "I"	Multimedia System "M"
5	Active Symbol or segment duration	a) 156 μ s b) 312 μ s c) 623 μ s d) 1 246 μ s	Not applicable	a) 252 μ s (Mode 1), 504 μ s (Mode 2), 1 008 μ s (Mode 3) b) 216 μ s (Mode 1), 432 μ s (Mode 2), 864 μ s (Mode 3) c) 189 μ s (Mode 1), 378 μ s (Mode 2), 756 μ s (Mode 3)	A pilot symbol is inserted every 250 μ s	a) 252 μ s (Mode 1), 504 μ s (Mode 2), 1 008 μ s (Mode 3) b) 216 μ s (Mode 1), 432 μ s (Mode 2), 864 μ s (Mode 3) c) 189 μ s (Mode 1), 378 μ s (Mode 2), 756 μ s (Mode 3)	a) 358.40 μ s (2k), 716.80 μ s (4k), 1 433.60 μ s (8k) b) 298.67 μ s (2k), 597.33 μ s (4k), 1 194.67 μ s (8k) c) 256 μ s (2k), 512 μ s (4k), 1 024 μ s (8k) d) 224 μ s (2k), 448 μ s (4k), 896 μ s (8k)	OFDM: a) 560 μ s (1k), b) 179.2 μ s (1k), 358.40 μ s (2k), 716.80 μ s (4k), 1 433.60 μ s (8k) c) 149.33 μ s (1k), 298.67 μ s (2k), 597.33 μ s (4k), 1 194.67 μ s (8k) d) 2 128 μ s (1k), 256 μ s (2k), 512 μ s (4k), 1 024 μ s (8k) e) 112 μ s (1k), 224 μ s (2k), 448 μ s (4k), 896 μ s (8k)	a) 885.6216 μ s b) 738.018 μ s c) 632.587 μ s d) 553.5135 μ s
6	Guard interval duration	a) 31 μ s b) 62 μ s c) 123 μ s d) 246 μ s	Not applicable	1/32, 1/16, 1/8, 1/4 of active symbol duration	A pilot symbol length is 125 μ s which acts as same as guard interval using RAKE receiver	1/32, 1/16, 1/8, 1/4 of active symbol duration	1/32, 1/16, 1/8, 1/4 of active symbol duration	1/32, 1/16, 1/8, 1/4 of active symbol duration	a) 110.7027 μ s b) 92.2523 μ s c) 79.0734 μ s d) 69.1892 μ s Supports path delays equals to 1.65* Guard Interval duration

TABLE 6 (continued)

	Parameters	Multimedia System "A"	Multimedia System "B"	Multimedia System "C"	Multimedia System "E"	Multimedia System "F"	Multimedia System "H"	Multimedia System "I"	Multimedia System "M"
7	Transmission unit (frame) duration	96 ms 48 ms 24 ms	968 ms (mobile/ handheld frame)	204 OFDM symbols	12.75 ms	204 OFDM symbols	68 OFDM symbols. One super-frame consists of 4 frames	68 OFDM symbols. One super-frame consists of 4 frames TDM: Frame comprised of 476 physical layer slots each of them comprising 2 176 symbols	Superframe – exactly 1 second in duration. In OFDM symbols. a) 1 000 b) 1 200 c) 1 400 d) 1 600 Each superframe consists of 4 frames of equal duration (approx 1/4 second in duration)
8	Time/ frequency synchroni- zation	Null symbol, centre frequency, and phase reference symbol	Training patterns	Pilot carriers	Assign one CDM channel to Pilot	Pilot carriers	Pilot carriers	OFDM: Pilot carriers TDM: Pilot symbols	Time-division (TDM) and frequency-division (FDM) pilot channels
9	Modulation methods	T-DMB: COFDM- DQPSK AT-DMB: COFDM- DQPSK COFDM-BPSK over DQPSK COFDM-QPSK over DQPSK	8-level VSB AM	DQPSK, QPSK, 16-QAM, 64-QAM	QPSK	DQPSK, QPSK, 16-QAM, 64-QAM	QPSK, 16-QAM, 64-QAM, MR-16-QAM, MR-64-QAM	OFDM: QPSK, 16-QAM TDM: QPSK, 8-PSK, 16-APSK	QPSK, 16-QAM, layered modulation

TABLE 6 (continued)

	Parameters	Multimedia System "A"	Multimedia System "B"	Multimedia System "C"	Multimedia System "E"	Multimedia System "F"	Multimedia System "H"	Multimedia System "I"	Multimedia System "M"
10	Coding and error correction methods	See Rec. ITU-R BS.1114 and additional RS (204, 188, T = 8) code for video service Turbo code (1/4 to 1/2) and additional RS (204, 188, T = 8) code for video service and scalable video service	Serial concatenated convolutional code (1/2 or 1/4 rate); cross-interleaved RS code (211,187), T = 12; (223,187), T = 18; or (235,187), T = 24; and CRC (2 bytes per M/H transport packet). Note M/H transport packet size is data-rate dependent.	Convolution code (1/2 to 7/8) and RS (204, 188) with time interleaving utmost 0.5 s	Convolutional code (1/2 to 7/8) and RS (204, 188) with bit-interleaving up to 6 s	Convolution code (1/2 to 7/8) and RS (204, 188) with time interleaving utmost 1 s	Inner code: Convolutional code, mother rate 1/2 with 64 states. Puncturing to rate 2/3, 3/4, 5/6, 7/8 Outer Code: RS (204, 188, T = 8) IP outer channel code: MPE-FEC RS (255,191)	Turbo Code from 3GPP2 with mother information block size of 12 282 bits. Rates obtained by puncturing: 1/5, 2/9, 1/4, 2/7, 1/3, 2/5, 1/2, 2/3	Inner code: parallel concatenated convolutional code (PCCC), rates 1/3, 1/2. And 2/3 for data, 1/5 for overhead information Outer code: RS with rates 1/2, 3/4, and 7/8

TABLE 6 (end)

	Parameters	Multimedia System "A"	Multimedia System "B"	Multimedia System "C"	Multimedia System "E"	Multimedia System "F"	Multimedia System "H"	Multimedia System "I"	Multimedia System "M"
11	Net data rates	a) T-DMB: 0.576 to 1.728 Mbit/s b) AT-DMB: 0.864 to 2.304 Mbit/s at BPSK over DQPSK c) AT-DMB: 1.152 to 2.88 Mbit/s at QPSK over DQPSK	0.1546 to (2x) 3.348 Mbit/s	a) 0.281 to 1.787 Mbit/s b) 0.328 to 2.085 Mbit/s c) 0.374 to 2.383 Mbit/s	Maximum: 26.011 Mbit/s Typical: 6.84 Mbit/s	n × a) 0.281 to 1.787 Mbit/s b) 0.328 to 2.085 Mbit/s c) 0.374 to 2.383 Mbit/s	a) 2.33-14.89 Mbit/s b) 2.80-17.87 Mbit/s c) 3.27-20.84 Mbit/s d) 3.74-23.82 Mbit/s All with MPE-FEC 3/4	OFDM: At MPEG-TS level and starting from the lower code rate with GI 1/4 to the higher rate with GI 1/32 a) 0,42 to 3.447 Mbit/s b) 1.332 Mbit/s to 10,772 Mbit/s c) 1.60 Mbit/s to 12.95 Mbit/s d) 1.868 Mbit/s to 15.103 Mbit/s e) 2.135 Mbit/s to 17.257 Mbit/s TDM with Roll Off 15%: a) 0.49 Mbit/s to 3.337 Mbit/s b) 1.53 Mbit/s to 10.41 Mbit/s c) 1.827 Mbit/s to 12.491 Mbit/s d) 2.172 Mbit/s to 14.164 Mbit/s e) 2.468 Mbit/s to 16.687 Mbit/s	a) 2.3-9.3 Mbit/s b) 2.8-11.2 Mbit/s c) 3.2-13 Mbit/s d) 3.7-14.9 Mbit/s (Rates above do not include the overhead due to use of RS coding)

⁽¹⁾ All parameters that may vary depending on selected channel bandwidth are listed in the order of corresponding channel bandwidths as shown in row 1 using sub-references a), b), c) and d), as applicable.

TABLE 7

Technical performance comparison of Multimedia broadcasting systems for mobile reception

	Multimedia System "A"	Multimedia System "B"	Multimedia System "C"	Multimedia System "E"	Multimedia System "F"	Multimedia System "H"	Multimedia System "I"	Multimedia System "M"
Spectrum efficiency (bit/s/Hz)	<p>T-DMB: From 0.375 (DQPSK, convolutional code rate 1/4) to 1.125 (DQPSK, convolutional code rate 3/4) bit/s/Hz</p> <p>AT-DMB: From 0.5625 (BPSK over DQPSK, convolutional code rate 1/4, turbo code 1/4) to 1.5 (BPSK over DQPSK, convolutional code rate 3/4, turbo code rate 1/2) bit/s/Hz</p> <p>AT-DMB: From 0.75 (QPSK over DQPSK, convolutional code rate 1/4, turbo code rate 1/4) to 1.875 (QPSK over DQPSK, convolutional code rate 3/4, turbo code rate 1/2) bit/s/Hz</p>	0.545 to 1.48 bits/Hz	From 0.655 bit/s/Hz (QPSK 1/2) to 4.170 bit/s/Hz (64-QAM 7/8)	<p>Up to 1.369 bit/s/Hz using 63 payload channels and one pilot channel with 7/8 convolutional code rate *1</p> <p>Typical 0.360 bit/s/Hz using 29 payload and one pilot CDM channels with 1/2 convolutional code rate *2</p>	From 0.655 bit/s/Hz (QPSK 1/2) to 4.170 bit/s/Hz (64-QAM 7/8)	From 0.46 bit/s/Hz (QPSK 1/2 MPE-FEC 3/4) to 1.86 bit/s/Hz (64-QAM 2/3 MPE-FEC 3/4)	<p>OFDM:</p> <ul style="list-style-type: none"> - With GI 1/4: From 0.2806 bit/s/Hz with QPSK 1/5 to 1.8709 bit/s/Hz with 16-QAM 2/3 - With GI 1/32: from 0.3402 bit/s/Hz with QPSK 1/5 to 2.2678 bit/s/Hz with 16-QAM 2/3 <p>TDM: From 0.36 bit/s/Hz with QPSK 1/5 to 2.44 bit/s/Hz with 16-APSK 2/3</p>	From 0.47 bit/s/Hz to 1.87 bit/s/Hz (No RS code) 0.35 to 1.40 bit/s/Hz with RS (16, 12) outer code

TABLE 7 (continued)

	Multimedia System "A"	Multimedia System "B"	Multimedia System "C"	Multimedia System "E"	Multimedia System "F"	Multimedia System "H"	Multimedia System "I"	Multimedia System "M"
Stable and reliable reception and QoS control in various types of receiving environments	<ul style="list-style-type: none"> - QoS based reception availability under various environment - BER performance of 10^{-8} required for video services. - Reliable mobile reception up to 300 km/h at T-DMB - Reliable mobile reception up to 300 km/h at BPSK over DQPSK 	<ul style="list-style-type: none"> - Variable QoS and robustness by use of various SCCC code rates and RS code rates - High mobility up to 300 km/h (UHF band, 1/4 rate SCCC, TU-6 condition) 	<ul style="list-style-type: none"> - Variable QoS and robustness - High mobility up to 300 km/h in 2k/4k/8k (QPSK, 1/2 convolutional code rate, UHF band) 	<ul style="list-style-type: none"> - Variable QoS and robustness - Reception of satellite signal by handheld and vehicular receivers as well as fixed receivers - High mobility up to aircraft speed for satellite signal reception 	<ul style="list-style-type: none"> - Variable QoS and robustness - High mobility up to 300 km/h in 2k/4k/8k (QPSK 1/2) 	<ul style="list-style-type: none"> - Outdoor and indoor reception with high QoS even with integrated antennas in a terminal - Robust pedestrian and mobile reception with 8k/4k/2k QPSK and 16-QAM modes 	<ul style="list-style-type: none"> - Network combining satellite and terrestrial reception - Long time interleaving for reception of satellite signal by handheld, vehicle-mounted or fixed terminal - Outdoor and indoor robust reception of terrestrial signal with very high QoS - Possible antenna diversity even with handheld terminal 	<ul style="list-style-type: none"> - Per channel QoS - Statistical multiplexing - High mobility: <ul style="list-style-type: none"> - ~500 km/h (QPSK 1/2, C/N = 10 dB) - ~320 km/h (16-QAM, C/N = 16.5 dB) - Good performance at low speed

TABLE 7 (end)

	Multimedia System "A"	Multimedia System "B"	Multimedia System "C"	Multimedia System "E"	Multimedia System "F"	Multimedia System "H"	Multimedia System "I"	Multimedia System "M"
Stable and reliable reception and QoS control in various types of receiving environments (cont.)	Typical SFN cell size is about 70 km (DQPSK, 1/2, guard interval 256 μ s) depending the frequency and transmission power.	SFN supported	SFN supported SFN is supported typically in 8k with selectable FEC code rate and carrier modulation scheme	A satellite signal covers nationwide area Terrestrial gap fillers cover shadow areas from a satellite signal	SFN supported SFN is supported typically in 8k with selectable FEC code rate and carrier modulation scheme Hierarchical transmission available	<ul style="list-style-type: none"> – Very high mobility (UHF, QPSK, CR 1/2 or 2/3): – 2k up to 1 185 km/h – 4k up to 592 km/h – 8k up to 296 km/h Typical SFN cell sizes are in the range of 60 to 100 km (8k, QPSK, 16-QAM) but even nationwide SFN is possible with 8k robust modes (QPSK) and limited Tx powers. With 4k and 2k the SFN-size is more limited or denser network is needed for wide SFN National/local services are supported Hierarchical modulation is possible	<ul style="list-style-type: none"> – Very high mobility (8 MHz, 2k, GI = 1/32, and QPSK 1/5) Supports up to 1 200 Hz Doppler shift <ul style="list-style-type: none"> – SH-A: SFN is supported, also between satellite and terrestrial networks – SH-B: Code combining between satellite and terrestrial signals – Under satellite coverage, no mobility limit – Local service insertion is supported 	<ul style="list-style-type: none"> – 3 km/h up to 300 km/h (QPSK 1/2 C/N = 7 dB) – 3 km/h up to 200 km/h (16-QAM 1/2 C/N = 13.5 dB) Low and high power (300 m, 50 kW) SFN in UHF is supported with 4k mode, 16-QAM 1/2 MFN network configuration also supported

*1 and *2: In the case of CDM chip rate with 16.384 MHz, occupied bandwidth is 19 MHz for a satellite signal.

For the highest case: CDM 63 payload channels and one pilot channel. Viterbi rate is 7/8. A payload TS packet rate is $16.384 \times 2 \times 7/8 \times 188/204 \times 63/64 / 19 = 1.369$ bit/s/Hz.

For a typical case: CDM 29 payload channels and one pilot channel. Viterbi rate is 1/2. A payload TS packet rate is $16.384 \times 2 \times 1/2 \times 188/204 \times 29/64 / 19 = 0.360$ bit/s/Hz.

Appendix 3

(Informative)

Additional information on Multimedia System “I” which combines a satellite component and a terrestrial component

Multimedia System “I”, is a system which provides IP-based media content and data over a combined satellite operating at frequencies below 3 GHz⁶ and terrestrial infrastructure integrated within national frequency plans.

The coverage by Multimedia System “I” is obtained by combining a satellite component and, where necessary, a complementary terrestrial component to ensure service continuity in areas where the satellite alone cannot provide the required quality of service.

⁶ More precisely satellite components are in the appropriate bands allocated to satellite services in the frequency range 1 452-2 690 MHz.