

## RECOMENDACIÓN UIT-R BT.1616

**Formato de tren de datos para el intercambio de señales de audio, de datos y de vídeo comprimidas en formato DV por medio de interfaces que se ajustan a la Recomendación UIT-R BT.1381**

(Cuestión UIT-R 12/6)

(2003)

La Asamblea de Radiocomunicaciones de la UIT,

*considerando*

- a) que se han identificado aplicaciones en la producción y la posproducción de televisión profesional en las que la compresión de señales de vídeo en formato DV puede ofrecer ventajas de explotación y económicas respecto a las operaciones basadas en la interfaz digital en serie (SDI);
- b) que se han propuesto tres velocidades de transferencia de datos dentro del mismo grupo de compresión para dar servicio a diferentes aplicaciones (25 Mbit/s, 50 Mbit/s y 100 Mbit/s);
- c) que las tramas de muestreo para cada una de las tres aplicaciones son diferentes;
- d) que los elementos de audio, datos auxiliares y metadatos son parte integrante de esas aplicaciones;
- e) que esos elementos se multiplexan en un tren de datos único, para su transporte y posterior procesamiento;
- f) que para continuar el posprocesamiento y el almacenamiento, el intercambio de información se efectuará a través de interfaces que se ajusten a la Recomendación UIT-R BT.1381;
- g) que para la interconexión de equipos de definición normal y de alta definición, el UIT-R recomienda que se utilicen las Recomendaciones UIT-R BT.656 y UIT-R BT.1120 respectivamente;
- h) que con ese objeto, se debe dar un formato al tren de datos complejos antes de su inserción en la interfaz mencionada;
- j) que este formato también debe describir los parámetros necesarios para la transmisión en modos más rápidos que el tiempo real,

*recomienda*

**1** que para las aplicaciones de producción y posproducción de televisión profesional que utilizan la compresión basada en DV, se dé un formato a los elementos integrantes, conforme a la Norma SMPTE 321M-2002 «Data Stream Format for the Exchange of DV-Based Audio, Data and Compressed Video over a Serial Data Transport Interface».

NOTA 1 – La Norma SMPTE 321M-2002 comprende una referencia normativa a la Norma SMPTE 296M-2001 «1280 × 720, Progressive Image Sample Structure – Analog and Digital Representation and Analog Interface». Los siguientes formatos indicados en el Cuadro 1 de la Norma SMPTE 296M, no deberán considerarse parte de la presente Recomendación.

Punto del Cuadro 1	Nomenclatura del sistema	Velocidad de trama
3	1280 × 720/50	50
6	1 280 × 720/25	25
7	1280 × 720/24	24
8	1280 × 720/23,98	24/1,001

### Resumen de la Norma SMPTE 321M-2002

Esta Norma define el formato del tren de datos para el intercambio síncrono de señales basadas en formato DV de audio, de datos y de vídeo comprimidas a través de una interfaz de transporte de datos en serie (SDTI). Comprende la transmisión de paquetes de audio, de datos de subcódigo y de vídeo comprimidos asociados con estructuras de datos en formato DV a velocidades de 25 Mbit/s, 50 Mbit/s y 100 Mbit/s para los sistemas 525/60i, 625/50i, 1080/60i, 1080/50i y 720/60p, incluida la transmisión más rápida que en tiempo real.

Esta Norma no comprende el tren de datos de una estructura en formato DV tal como se define en las Normas CEI 61834 y SMPTE 322M.

El espacio de la SDTI no utilizado por un tren de datos conforme a esta Norma, se puede utilizar para la transmisión de datos que no sean los que representan las señales de audio, de datos y de vídeo comprimidas en formato DV.

NOTA 1 – Las Normas SMPTE 321M-2002 y 296M-2001 figuran en los Anexos 1 y 2. Las Normas SMPTE 321M-2002 y 296M-2001 se refieren únicamente a las versiones 2002 y 2001 respectivamente, que son las aprobadas el 3.05.03 por las Administraciones de los Estados Miembros de la UIT en cumplimiento de lo dispuesto en la Resolución UIT-R 1-3. En virtud del acuerdo entre la UIT y la SMPTE, la SMPTE ha facilitado y autorizado la utilización de estas versiones y el UIT-R ha aceptado su inclusión en la presente Recomendación. Cualquier versión posterior de las Normas SMPTE 321M y 296M que no hayan sido aceptadas y aprobadas por la Comisión de Estudio 6 de Radiocomunicaciones no formará parte de la presente Recomendación. Las últimas versiones de los Documentos de la SMPTE se pueden consultar en el sitio web de la SMPTE: <http://www.smpite.org/>.

---

# SMPTE STANDARD

**SMPTE 321M-2002**

Revision of  
SMPTE 321M-1999

for Television —

## Data Stream Format for the Exchange of DV-Based Audio, Data and Compressed Video over a Serial Data Transport Interface



---

Page 1 of 24 pages

### 1 Scope

**1.1** This standard defines the format of the data stream for the synchronous exchange of DV-based audio, data, and compressed video (whose data structure is defined in SMPTE 314M and SMPTE 370M) over the interface defined in SMPTE 305M. It covers the transmission of audio, subcode data, and compressed video packets associated with DV-based 25- and 50-Mb/s data structures including faster-than-real-time transmission, and 100-Mb/s data structures for 525/60 SDTI and 625/50 SDTI systems.

**1.2** This standard does not include the data stream of a DV-compressed structure as defined in SMPTE 322M.

**1.3** Space within SMPTE 305M not used by a data stream conforming to this standard may be used for the transmission of data other than those representing DV-based audio, data, and compressed video.

**1.4** In this standard, the 60-Hz system refers to the field frequency 59.94-Hz system and the 50-Hz system refers to the field frequency 50.0-Hz system.

### 2 Normative references

The following standards contain provisions which, through reference in this text, constitute provisions of this standard. At the time of publication, the editions indicated were valid. All standards are subject to revision, and parties to agreements based on this standard are encouraged to investigate the possibility of applying the most recent edition of the standards indicated below.

SMPTE 274M-1998, Television — 1920 x 1080 Scanning and Analog and Parallel Digital Interfaces for Multiple Picture Rates

SMPTE 296M-2001, Television — 1280 x 720 Progressive Image Sample Structure — Analog and Digital Representation and Analog Interface

SMPTE 305.2M-2000, Television — Serial Data Transport Interface (SDTI)

SMPTE 314M-1999, Television — Data Structure for DV-Based Audio, Data and Compressed Video — 25 and 50 Mb/s

SMPTE 370M, Television — Data Structure for DV-Based Audio, Data and Compressed Video at 100 Mb/s — 1080/60i, 1080/50i, 720/60p

SMPTE 321M-2002

### 3 Identification within the serial data transport interface (SDTI)

#### 3.1 SDTI header packet data

The header packet data words of the serial data transport interface (SDTI) associated with this data stream format shall conform to SMPTE 305M. When the SDTI interface is transporting a data stream conforming to this standard, the block type word within the SDTI header packet shall have the value 173<sub>h</sub> for transported data contained in fixed-size blocks when ECC (error correction code) is used and the value 233<sub>h</sub> when ECC is not used.

#### 3.2 Payload

The payload is composed of consecutive fixed-size blocks (see figure 1). The SDTI data type word shall identify the data type of this payload with the value 221<sub>h</sub>.

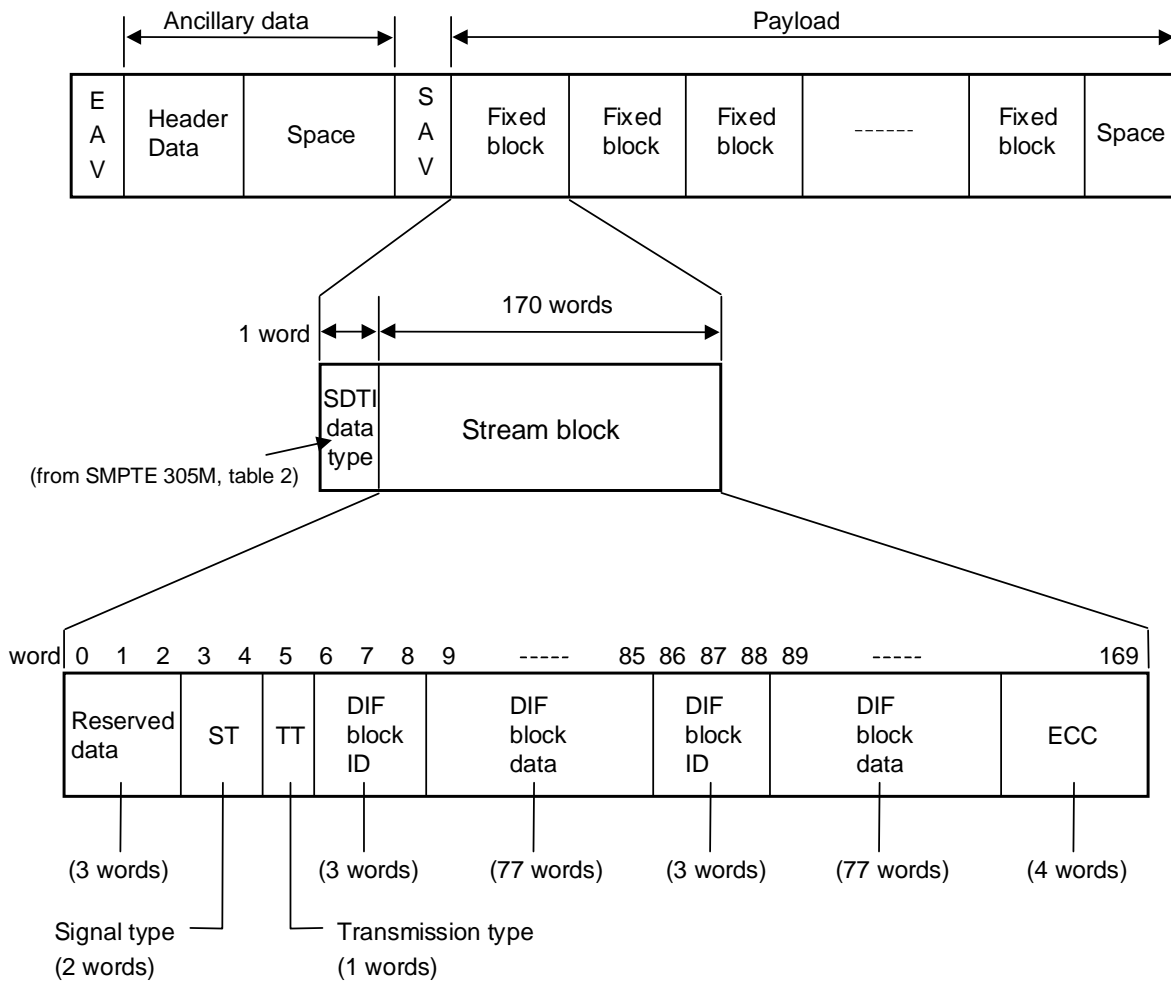

Figure 1 – Stream block format

**4 Stream block format**

The stream block format is shown in figure 1. The length of each stream block is 170 words, including a secondary header, two DIF (digital interface) block IDs, two DIF block data (of stream data), and an ECC block. The secondary header contains reserved data words, signal type words, and a transmission type word. The complete word structure of the stream block for a compressed video data stream is defined below:

- Reserved data: 3 words
- Signal type: 2 words
- Transmission type: 1 word
- DIF block ID: 3 words
- DIF block data: 77 words
- DIF block ID: 3 words
- DIF block data: 77 words
- ECC: 4 words

**4.1 Reserved data words**

The reserved data words shall consist of 3 words and be positioned at the start of the stream block. The default value for the reserved data is 200h.

**4.2 Signal type words**

The signal type word (ST) mapping is shown in figure 2. The signal type words shall consist of two words. The first word of ST (word 3) includes the specific type of video frame ID (STVF ID). The second word of ST (word 4) includes the field/frame frequency flag (FF), the DIF structure format, the DIF valid flag (DVF), the frame sequence number flag (FSNF), the transmission rate flag (TRF), and reserved bits.

	B9	B8	B7	B6	B5	B4	B3	B2	B1	B0
word 3	$\overline{EP}$	EP		Reserved				STVF ID		
word 4	$\overline{EP}$	EP	FF	DIF structure			Re <sub>v</sub>	DVF	FSNF	TRF

**Figure 2 – Signal type (ST) word mapping**

**Word 3 of ST**

The STVF ID shows information mainly related to pictures that have been 3:2 pull-down converted from 480 line/29.98 frame rate progressive pictures.

In the case of the 25- and 50-Mb/s structure for the 525/60 SDTI system, the following applies:

Bits B7 through B3 are reserved bits and shall be set to 00000<sub>b</sub> as default values.

Bits B2 through B0 indicate the specific type of video frame ID which shows the type of the converted picture with the following values:

## SMPTE 321M-2002

B2	B1	B0	Original	Converted
0	0	0	: 480i / 29.97	-> No change
0	0	1	: 480p / 29.97	-> Segmented frame (see note)
0	1	0	: 480p / 23.98	-> No field sequence ID (3:2 pull down)
0	1	1	: 480p / 23.98	-> A frame (3:2 pull down)
1	0	0	: 480p / 23.98	-> B frame (3:2 pull down)
1	0	1	: 480p / 23.98	-> C frame (3:2 pull down)
1	1	0	: 480p / 23.98	-> D frame (3:2 pull down)
1	1	1	: 480p / 23.98	-> E frame (3:2 pull down)

NOTE – Odd lines of 480p/29.97 are mapped to the first field and even lines of 480p/29.97 are mapped to the second field.

In the case of the 100-Mb/s structure for the 525/60 SDTI system and in the case of the 25-, 50-, and 100-Mb/s structures for the 626/50 SDTI system, the following applies:

All values of bits B7 through B0 are set to 00<sub>h</sub> as default values.

Bit B8 of word 3 is equal to the even parity of B7 through B0.

Bit B9 of word 3 is equal to the complement of B8.

**Word 4 of ST**

Bit B7 indicates the field frequency of the serial digital interface (SDTI) with the following values:

B7	
0	: 60 Hz (59.94 Hz)
1	: 50 Hz

Bits B6 through B4 indicate the DIF structure with the following values:

B6	B5	B4	
0	0	0	: Reserved
0	0	1	: Reserved
0	1	0	: Reserved
0	1	1	: 25-Mb/s structure
1	0	0	: Reserved
1	0	1	: 50-Mb/s structure
1	1	0	: 100-Mb/s structure
1	1	1	: Reserved

Bit B3 is the reserved bit and shall be set to 0<sub>b</sub> as the default value.

Bit B2 is the DIF valid flag (DVF) and indicates the validity of the DIF data mapped into SDTI.

B2	
0	: Invalid
1	: Valid

Bit B1 is the frame sequence number flag (FSNF) and indicates the validity of the frame sequence number (see 4.3) with the following values:

B1	
0	: Valid
1	: Invalid

Bit B0 is the transmission rate flag (TRF) and indicates the validity of the transmission rate (see 4.3) with the following values:

- B0
- 0 : Valid
- 1 : Invalid

Bit B8 is equal to the even parity of B7 through B0.  
 Bit B9 is equal to the complement of B8.

**4.3 Transmission type word**

The transmission type word (TT) mapping is shown in figure 3. The transmission type word shall consist of one word including the frame sequence number and the transmission rate.

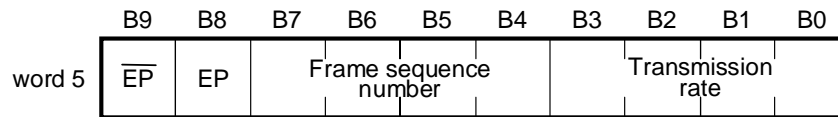

**Figure 3 – Transmission type (TT) word mapping**

Bits B7 through B4 indicate the frame sequence number with the following values:

- 0<sub>h</sub> : 1
- 1<sub>h</sub> : 2
- |
- F<sub>h</sub> : 16

The frame sequence number identifies frames multiplexed within an SDTI frame.

Bits B3 through B0 indicate the transmission rate with the following values:

- 0<sub>h</sub> : 1 x (normal transmission rate) (see note)
- 1<sub>h</sub> : 2 x
- 2<sub>h</sub> : 3 x
- 3<sub>h</sub> : 4 x
- 4<sub>h</sub> : 5 x
- 5<sub>h</sub> : 6 x
- 6<sub>h</sub> : 7 x
- 7<sub>h</sub> : 8 x
- 8<sub>h</sub> - E<sub>h</sub> : Reserved
- F<sub>h</sub> : 16 x

NOTE – The multiple of the normal transmission rate is represented by x. The normal transmission rate corresponding to normal reproduction of the television picture is 1 x.

Bit B8 is equal to the even parity of B7 through B0.  
 Bit B9 is equal to the complement of B8.

SMPTE 321M-2002

#### 4.4 DIF block ID words

The DIF block ID (ID0-2) shall consist of three words contained in bits A23 through A0 as shown in figure 4. The lower 8-bit portion of these three words is specified in SMPTE 314M and SMPTE xxxM.

	B9	B8	B7	B6	B5	B4	B3	B2	B1	B0
word 6 and 86	$\overline{\text{EP1}}$	EP1	A7	A6	A5	A4	A3	A2	A1	A0
word 7 and 87	$\overline{\text{EP2}}$	EP2	A15	A14	A13	A12	A11	A10	A9	A8
word 8 and 88	$\overline{\text{EP3}}$	EP3	A23	A22	A21	A20	A19	A18	A17	A16

Figure 4 – Mapping of DIF block ID

EP1 is equal to the even parity of bits A7 through A0;  
 EP2 is equal to the even parity of bits A15 through A8;  
 EP3 is equal to the even parity of bits A23 through A16;  
 and

$\overline{\text{EP1}}$  is equal to the complement of EP1;  
 $\overline{\text{EP2}}$  is equal to the complement of EP2;  
 $\overline{\text{EP3}}$  is equal to the complement of EP3.

#### 4.5 DIF block data words

The DIF block data shall consist of 77 words. The lower 8 bits of each DIF block word represent the DIF block data, as specified in SMPTE 314M and SMPTE xxxM; the higher 2 bits are parity data.

Bits B7 through B0 are DIF block data; Bit B8 is equal to the even parity of B7 through B0.  
 Bit B9 is equal to the complement of B8.

#### 4.6 Error correction code (ECC) words

Bits B7 through B0 of the words within a stream block (including reserved data words, the ST word, the TT word, and all words of the DIF block ID and DIF block data) are optionally protected by an error correction code (ECC). The ECC shall consist of four words and be inserted at the end of the stream block.

The error correction code is a (170, 166) Reed-Solomon code in GF(256), whose field generator polynomial is shown as:

$$P(x) = X^8 + X^4 + X^3 + X^2 + 1$$

where  $X^i$  are place-keeping variables in GF(2), the binary field. The generator polynomial of the code in GF(256) is:

$$G(x) = (x+\alpha)(x+\alpha^2)(x+\alpha^3)(x+\alpha^4)$$

where  $\alpha$  is given by  $2_h$  in GF(256).



When the value of the block type in the SDTI header (see 3.1) is 173<sub>h</sub>, the Reed-Solomon code shall be contained in C31 through C0 as shown in figure 5. When the value of the block type is 233<sub>h</sub>, the ECC shall have the fixed value 200<sub>h</sub>.

	B9	B8	B7	B6	B5	B4	B3	B2	B1	B0
word 166	$\overline{\text{EP1}}$	EP1	C7	C6	C5	C4	C3	C2	C1	C0
word 167	$\overline{\text{EP2}}$	EP2	C15	C14	C13	C12	C11	C10	C9	C8
word 168	$\overline{\text{EP3}}$	EP3	C23	C22	C21	C20	C19	C18	C17	C16
word 169	$\overline{\text{EP4}}$	EP4	C31	C30	C29	C28	C27	C26	C25	C24

Figure 5 – Mapping of ECC

EP1 is equal to the even parity of bits C7 through C0;  
 EP2 is equal to the even parity of bits C15 through C8;  
 EP3 is equal to the even parity of bits C23 through C16;  
 EP4 is equal to the even parity of bits C31 through C24;

and

$\overline{\text{EP1}}$  is equal to the complement of EP1;  
 $\overline{\text{EP2}}$  is equal to the complement of EP2;  
 $\overline{\text{EP3}}$  is equal to the complement of EP3;  
 $\overline{\text{EP4}}$  is equal to the complement of EP4.

## 5 Transmission order

The transmission order within one frame for 25-, 50-, and 100-Mb/s DV-based compression structures consisting of DIF blocks is shown in figures 6, 7, 8, and 9.

In the 100-Mb/s structure, one frame is carried in four channels, which are transmitted in sequence from the first channel to the fourth channel one after another. In the 50-Mb/s structure, each frame is carried in two channels, which are transmitted in sequence one after another. In the 25-Mb/s structure, only a single channel is used.

Each channel consists of 10 DIF sequences in the 60-Hz system or 12 DIF sequences in the 50-Hz system. DIF sequences within a frame are transmitted in a DIF sequence order from 0 to n-1. Each DIF sequence is composed of 150 DIF blocks. DIF blocks within a DIF sequence are transmitted sequentially from DIF block 0 to 149.

SMPTE 321M-2002

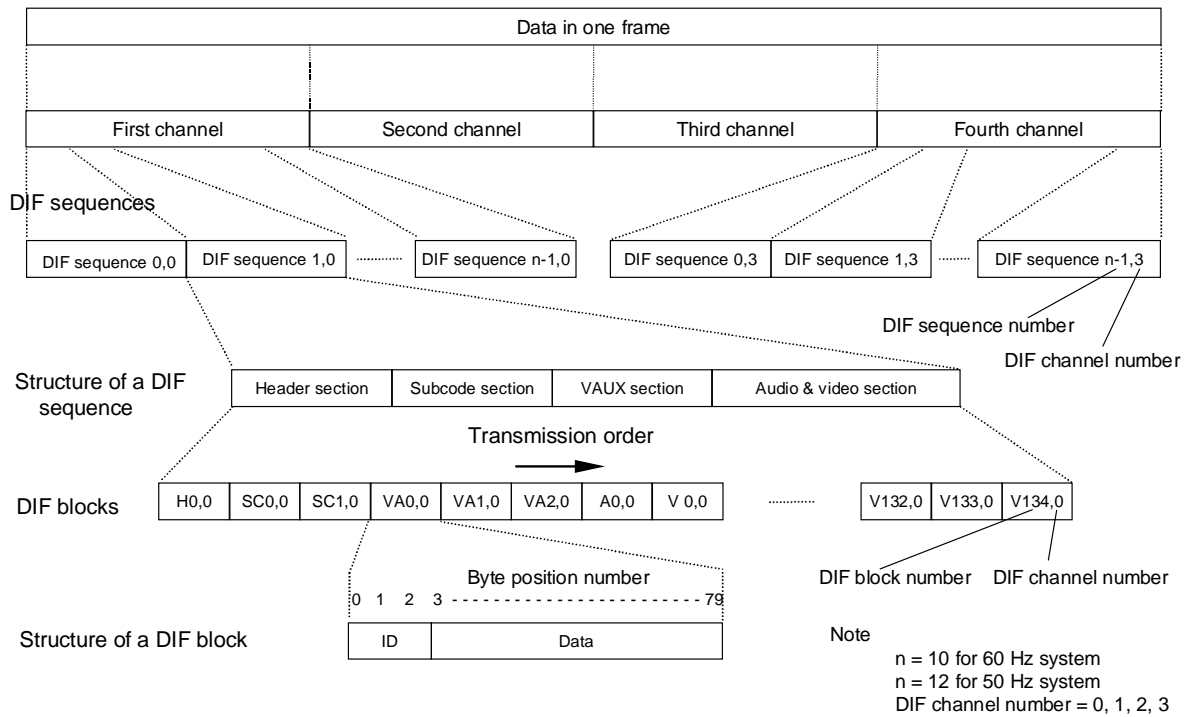

Figure 6 – Transmission order in one frame for the 100-Mb/s structure

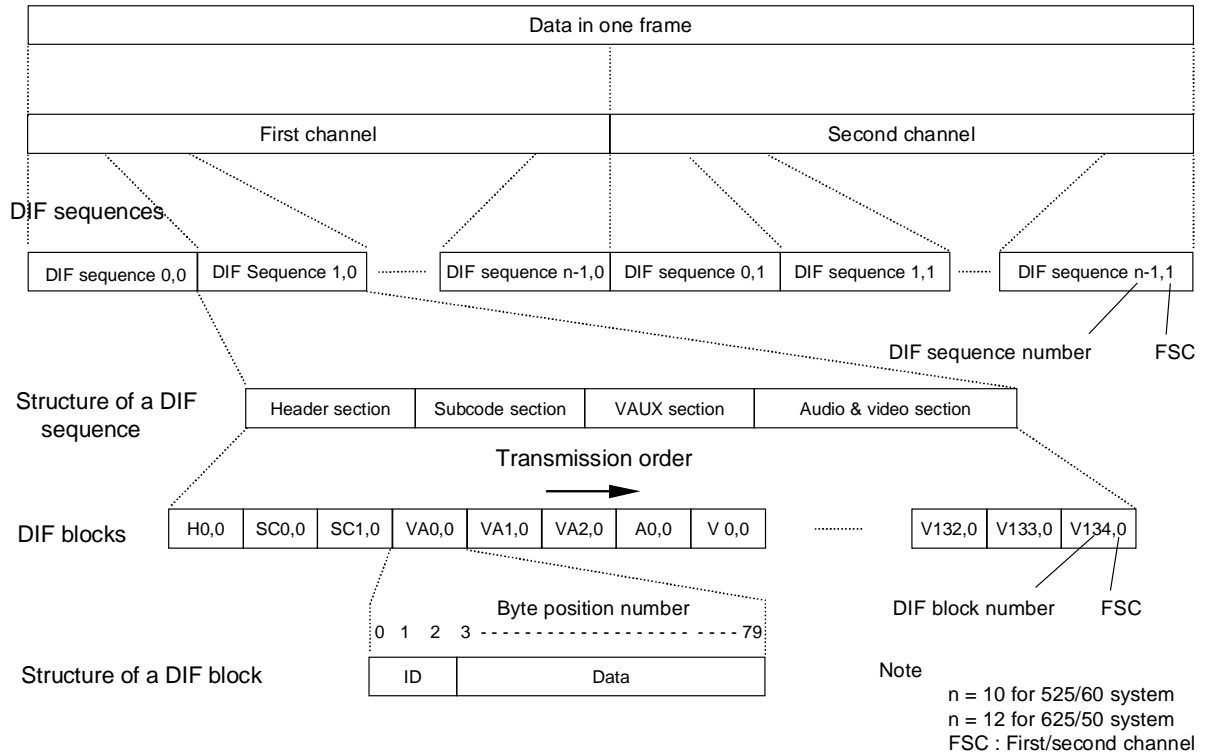

Figure 7 – Transmission order in one frame for the 50-Mb/s structure

SMPTE 321M-2002

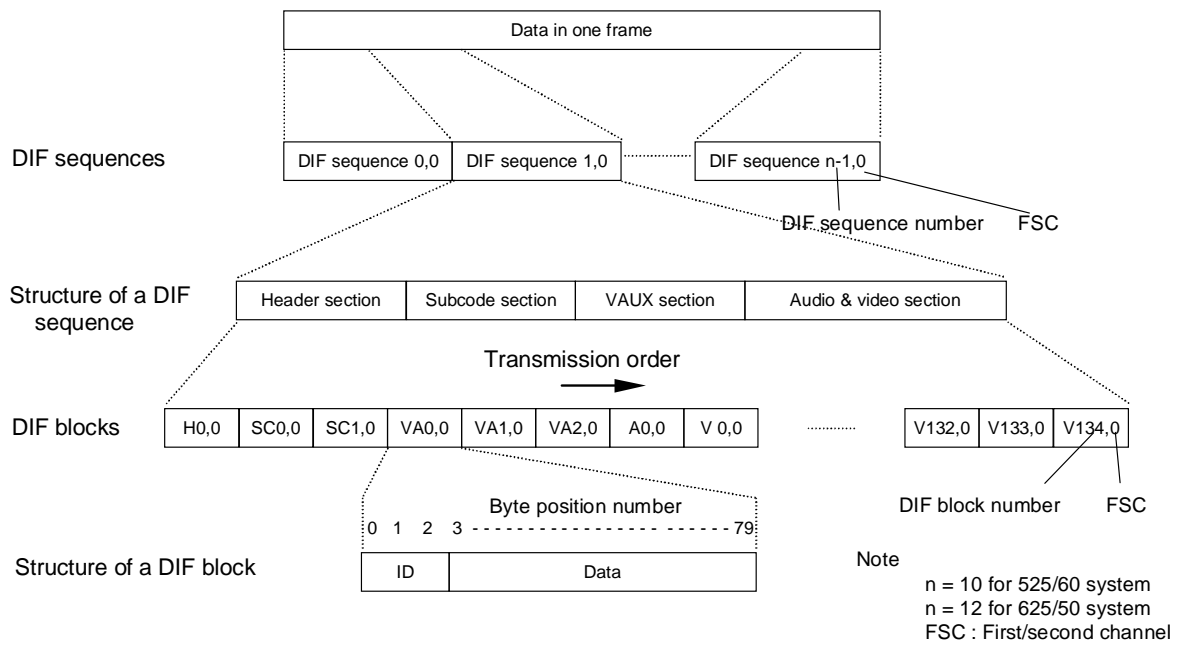
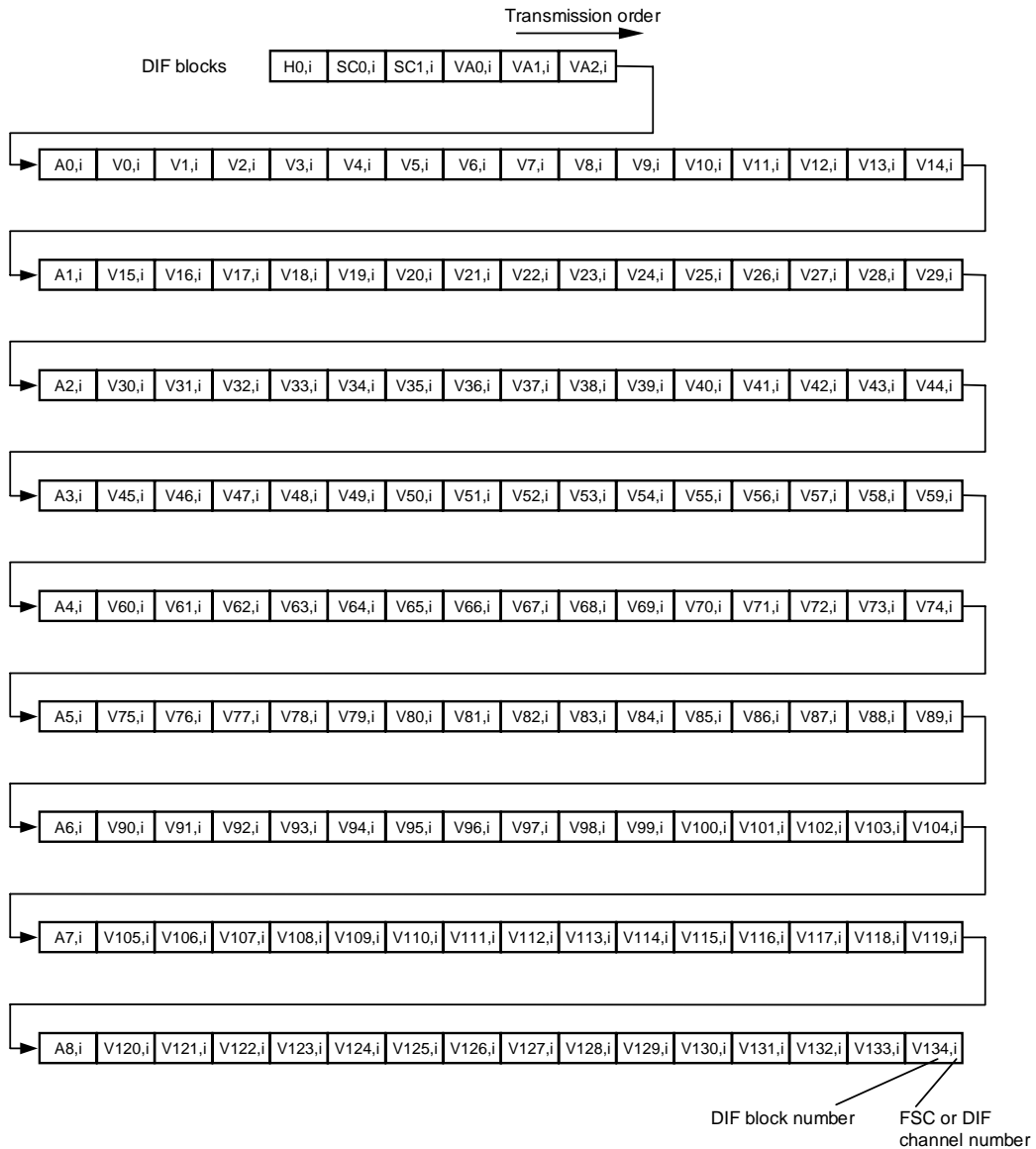

Figure 8 – Transmission order in one frame for the 25-Mb/s structure



NOTES

i : FSC i=0 for 25-Mb/s structure

FSC i=0,1 for 50-Mb/s structure

DIF channel number i=0,1,2,3 for 100-Mb/s structure

H0,i : DIF block in header section

SC0,i to SC1,i : DIF blocks in subcode section

VA0,i to VA2,i : DIF blocks in VAUX section

A0,i to A8,i : DIF blocks in audio section

V0,i to V134,i : DIF blocks in video section

The DIF channel number is defined by FSC and FSP as described in table 5 of SMPTE 370M.

Figure 9 – Transmission order in a DIF sequence

SMPTE 321M-2002

## 6 Mapping structure

The mapping structure defines where SDTI stream blocks are mapped into SDTI frames.

An SDTI data block of the fixed-block variety (as used by this standard) is based on one stream block; the stream block in turn includes two DIF blocks and associated words, as shown in figure 1.

– In the 525/60 SDTI system, the compressed video data stream within an SDTI frame is composed of 750 SDTI data blocks (1500 DIF blocks) for the 25-Mb/s compression structure or 1500 SDTI data blocks (3000 DIF blocks) for the 50-Mb/s structure or 3000 SDTI data blocks (6000 DIF blocks) for the 100-Mb/s structure.

– In the 625/50 SDTI system, the compressed video data stream within an SDTI frame is composed of 900 SDTI data blocks (1800 DIF blocks) for the 25-Mb/s compression structure or 1800 SDTI data blocks (3600 DIF blocks) for the 50-Mb/s structure or 3600 SDTI data blocks (7200 DIF blocks) for the 100-Mb/s structure.

### 6.1 Channel unit

The channel unit structure is shown in figures 10 and 11. A channel unit is a series of SDI raster lines into which SDTI data blocks are mapped. In the case of 25-Mb/s structure transmission, a channel unit is composed of the SDTI data blocks of one frame (see 6.2 for the 50- and 100-Mb/s structures).

A channel unit is thus composed of 750 SDTI data blocks for the 525/60 SDTI system or 900 SDTI data blocks for the 625/50 SDTI system.

In the 525/60 SDTI system, a channel unit occupies 94 lines in the 270-Mb/s interface or 69 lines in the 360-Mb/s interface; in the 625/50 SDTI system, a channel unit occupies 113 lines in the 270-Mb/s interface or 82 lines in the 360-Mb/s interface.

The remaining payload space within a channel unit should be filled with blocks with their value set to the invalid type number 100h, as defined in SMPTE 305M.

### 6.2 Mapping rules

The mapping rules are as follows:

- Channel units consist of contiguous lines with no gaps and shall not use lines 10, 11, 273, or 274 in the 525/60 SDTI system, or lines 6, 7, 319, or 320 in the 625/50 SDTI system.
- The start lines in which a channel unit can be mapped are shown in table 1.
- A channel unit shall be completely contained within an SDI video field.
- Multiple channel units shall not be mapped into the same line and shall not be interleaved with each other.
- For faster-than-real-time transmission, the mapping order of channel units shall be in time sequence.

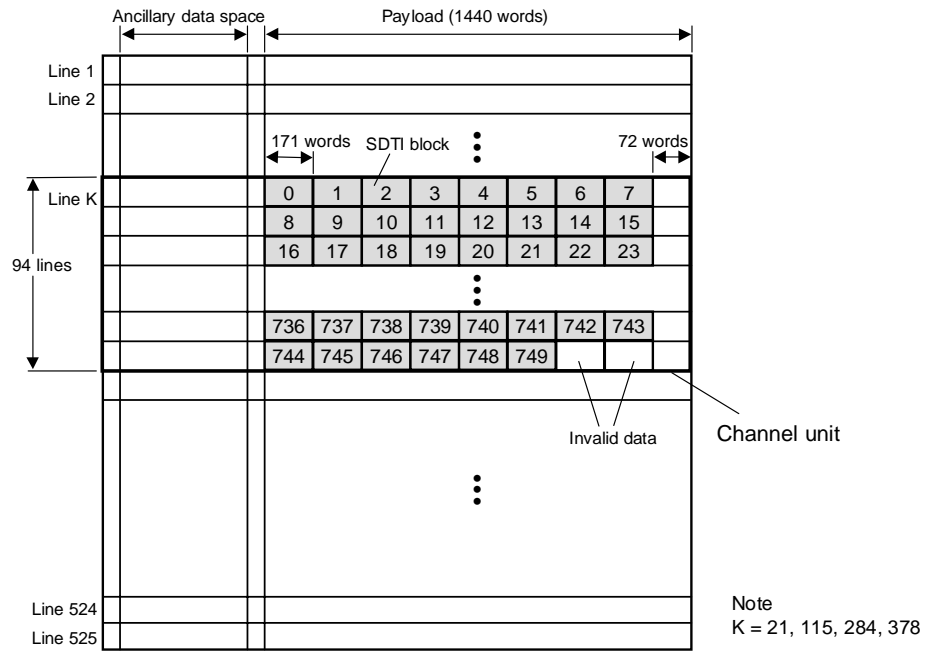

a) for 270 Mb/s system

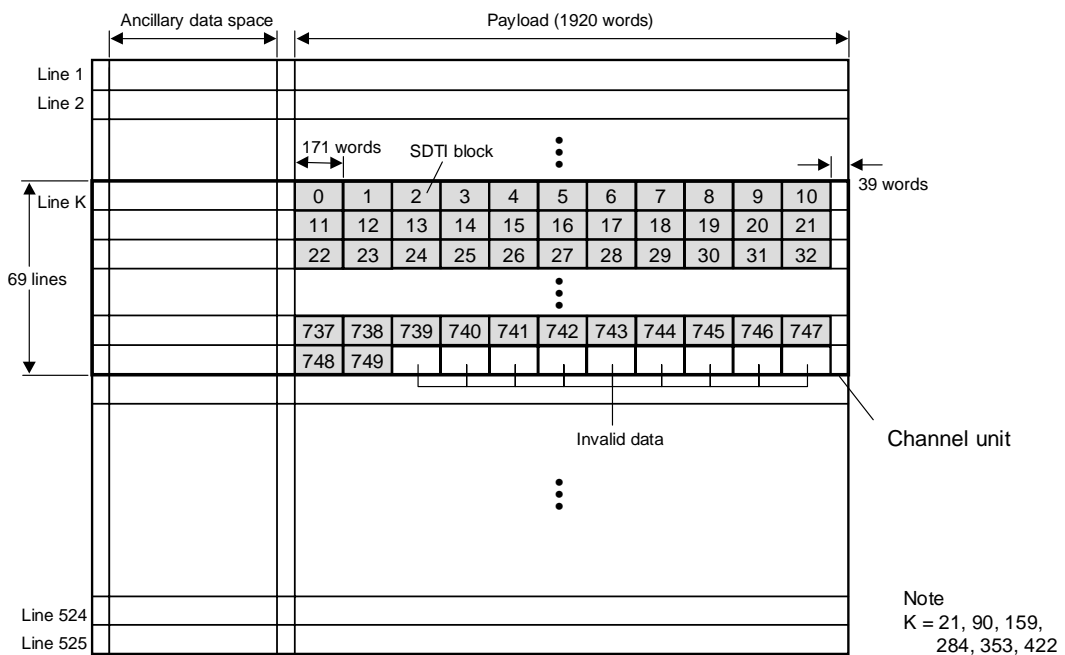

b) for 360 Mb/s system

Figure 10 – Channel unit mapping for the 25-Mb/s structure (525/60 SDTI system)

SMPTE 321M-2002

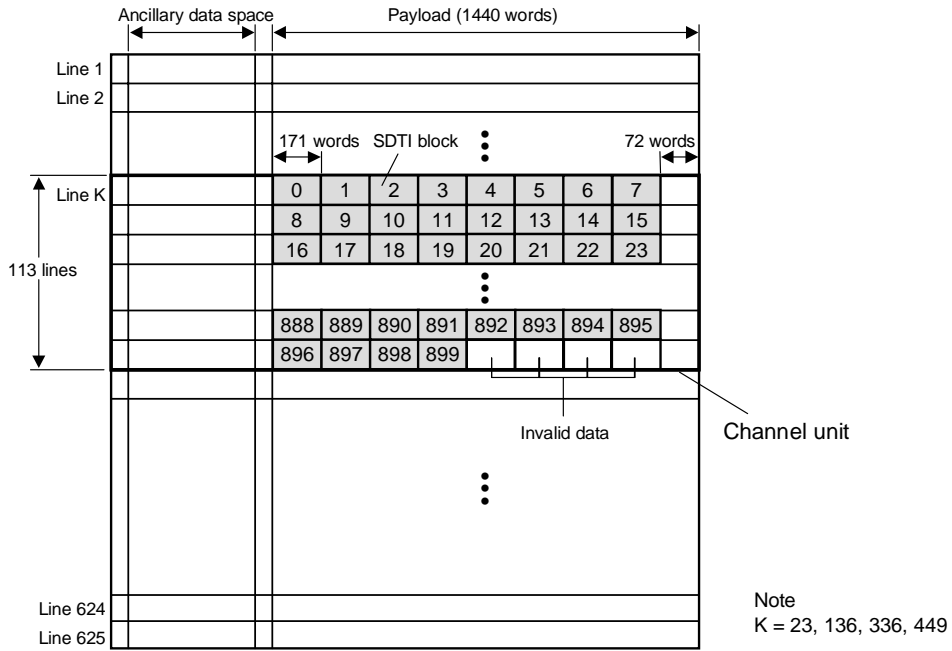

a) for 270 Mb/s system

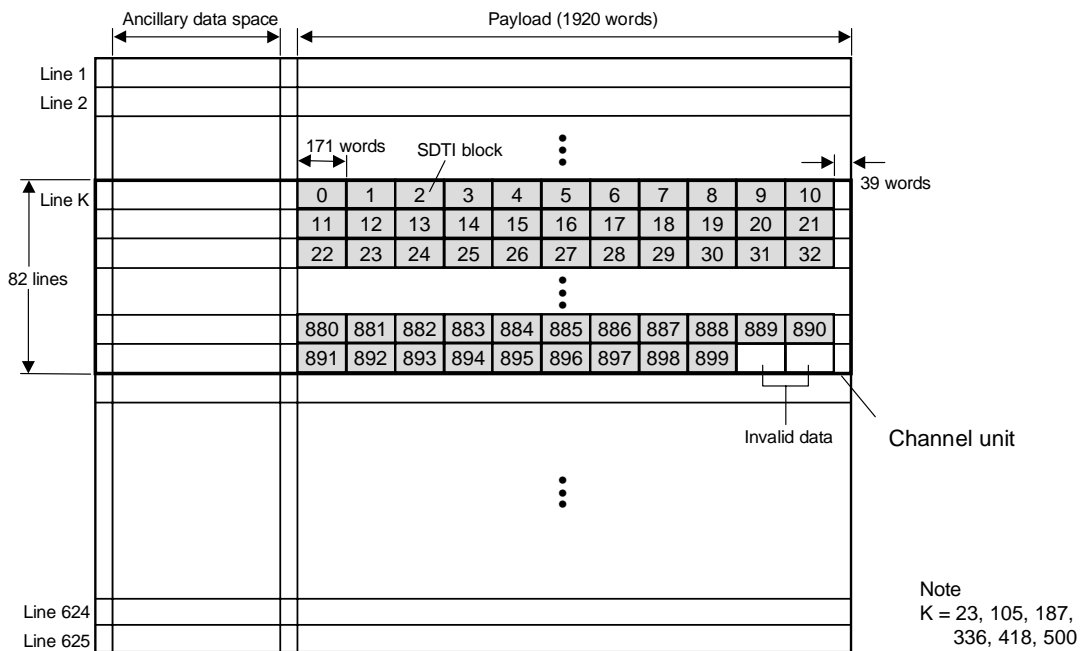

b) for 360 Mb/s system

Figure 11 – Channel unit mapping for the 25-Mb/s structure (625/50 SDTI system)



**Table 1 – Start lines of channel units**

525/60 SDTI system	270-Mb/s interface	21, 115, 284, 378
	360-Mb/s interface	21, 90, 159, 284, 353, 422
625/50 SDTI system	270-Mb/s interface	23, 136, 336, 449
	360-Mb/s interface	23, 105, 187, 336, 418, 500

In the case of synchronized multichannel unit transmission, the mapping of channel units shall be in fixed positions as shown in figures 12 and 13. One SDTI frame shall contain 4-channel units with the 270-Mb/s interface or 6-channel units with the 360-Mb/s interface.

In the case of 50-Mb/s structure transmission, one frame shall use two adjacent channel units as shown in figures 14 and 15. The first part of one frame shall use the first channel unit and the second part of the frame shall use the second channel unit.

In the 525/60 system, 1500 SDTI data blocks are mapped into 188 lines for the 270-Mb/s interface or into 138 lines for the 360-Mb/s interface.

In the 625/50 system, 1800 SDTI data blocks are mapped into 226 lines for the 270-Mb/s interface or into 164 lines for the 360-Mb/s interface.

In the case of 100-Mb/s structure transmission, one frame shall use four adjacent channel units as shown in figures 16 and 17. The first part of one frame shall use the first channel unit, the second part of the frame shall use the second channel unit, the third part of the frame shall use the third channel unit, and the fourth part of the frame shall use the fourth channel unit.

In the 525/60 SDTI system, 3000 SDTI data blocks are mapped into 376 lines for the 270-Mb/s interface or into 276 lines for the 360-Mb/s interface.

In the 625/50 SDTI system, 3600 SDTI data blocks are mapped into 452 lines for the 270-Mb/s interface or into 328 lines for the 360-Mb/s interface.

In the case of faster-than-real-time transmission, SDTI data blocks are mapped into adjacent multiple channel units.

SMPTE 321M-2002

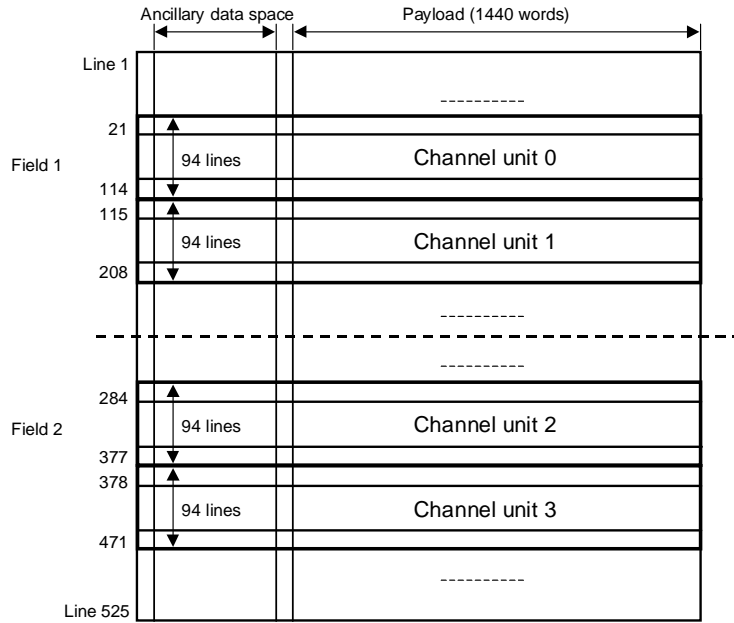

a) for 270 Mb/s system

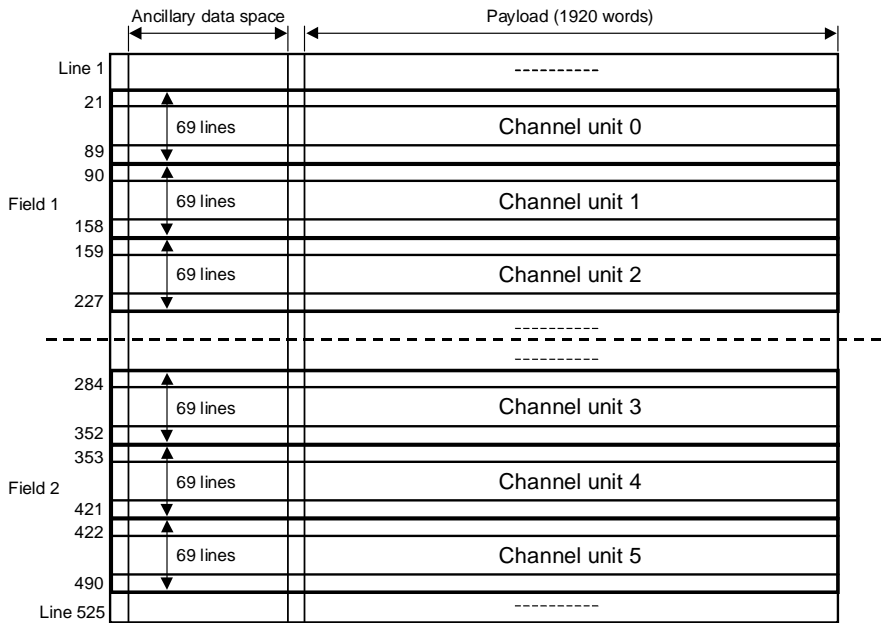

b) for 360 Mb/s system

Figure 12 – Channel unit mapping in a synchronized multichannel unit transmission (525/60 SDTI system)

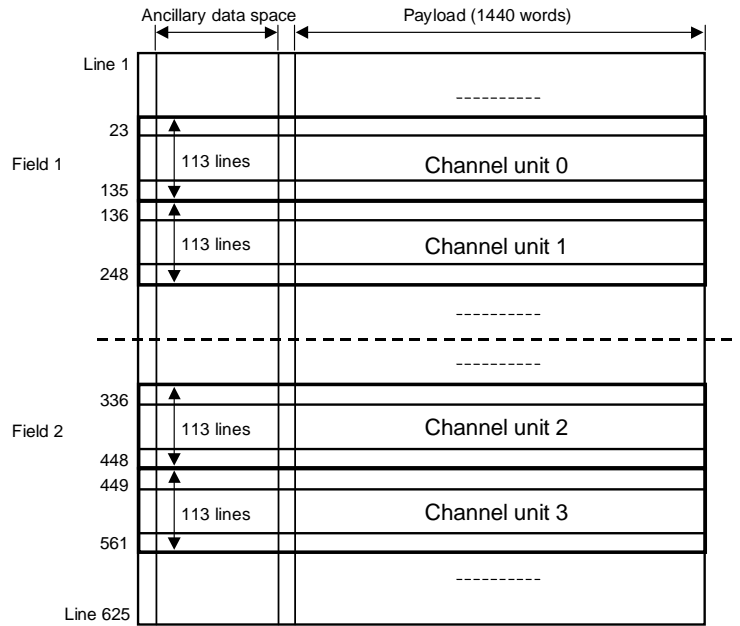

a) for 270 Mb/s system

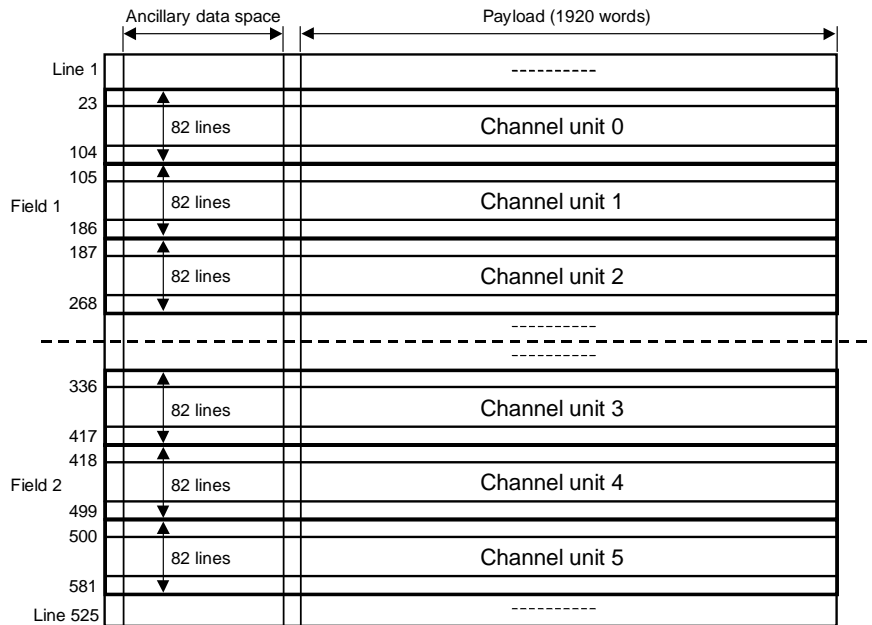

b) for 360 Mb/s system

Figure 13 – Channel unit mapping in a synchronized multichannel unit transmission (625/50 SDTI system)

SMPTE 321M-2002

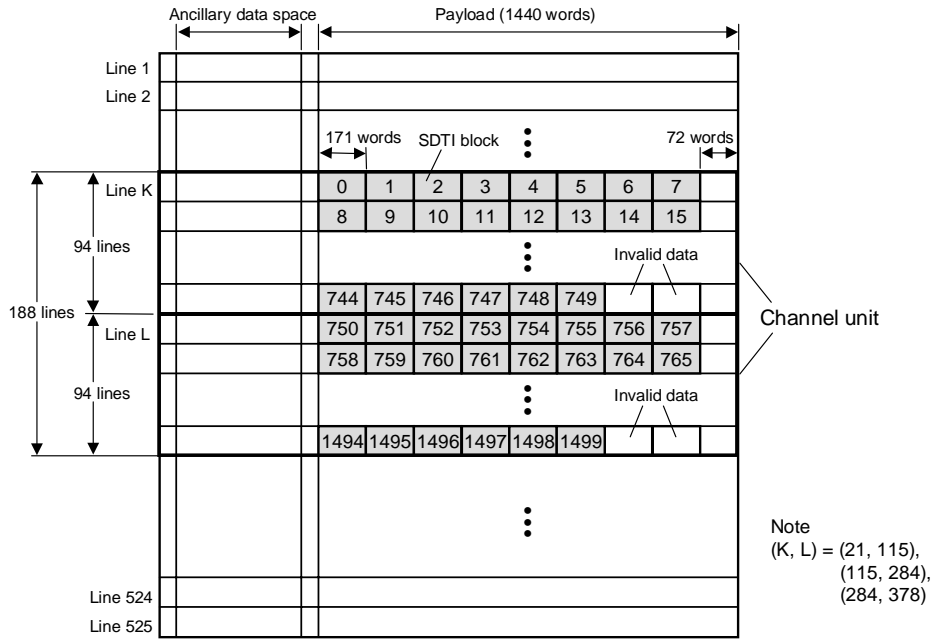

a) for 270 Mb/s system

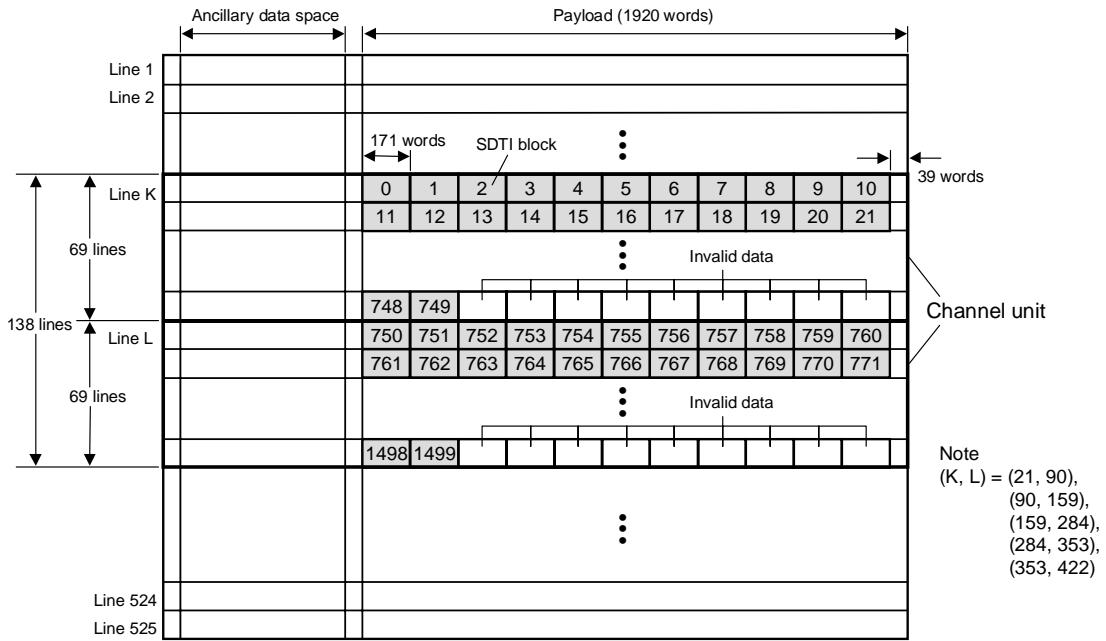

b) for 360 Mb/s system

Figure 14 – Channel unit mapping for the 50-Mb/s structure (525/60 SDTI system)

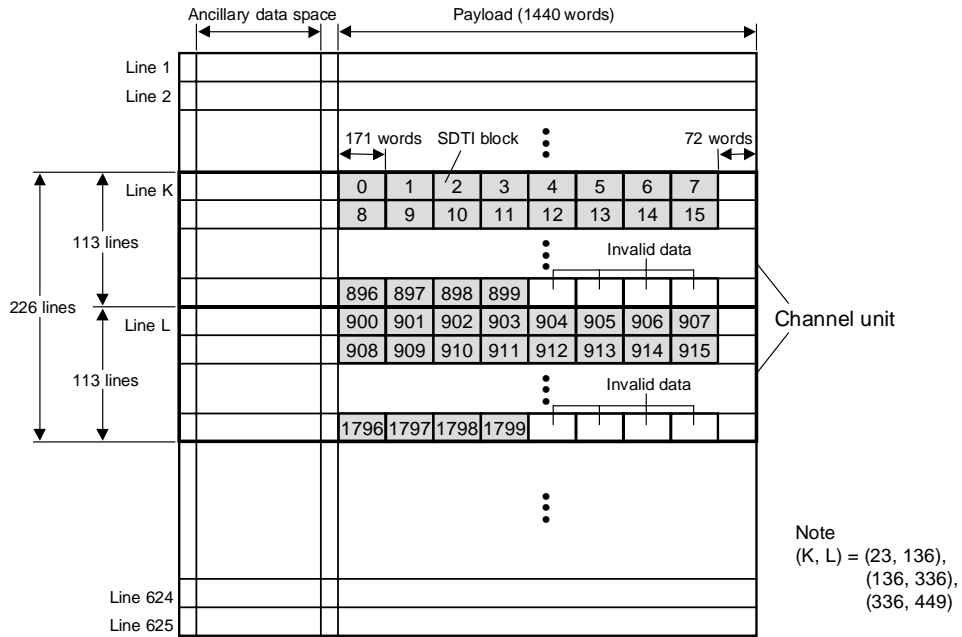

a) for 270 Mb/s system

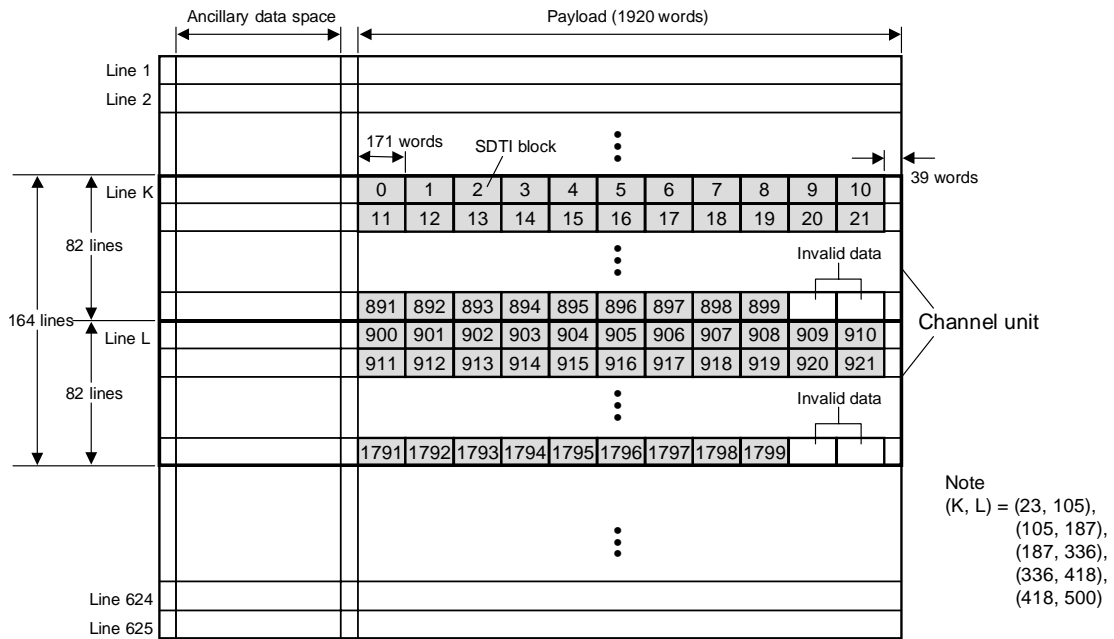

b) for 360 Mb/s system

Figure 15 – Channel unit mapping for the 50-Mb/s structure (625/50 SDTI system)

SMPTE 321M-2002

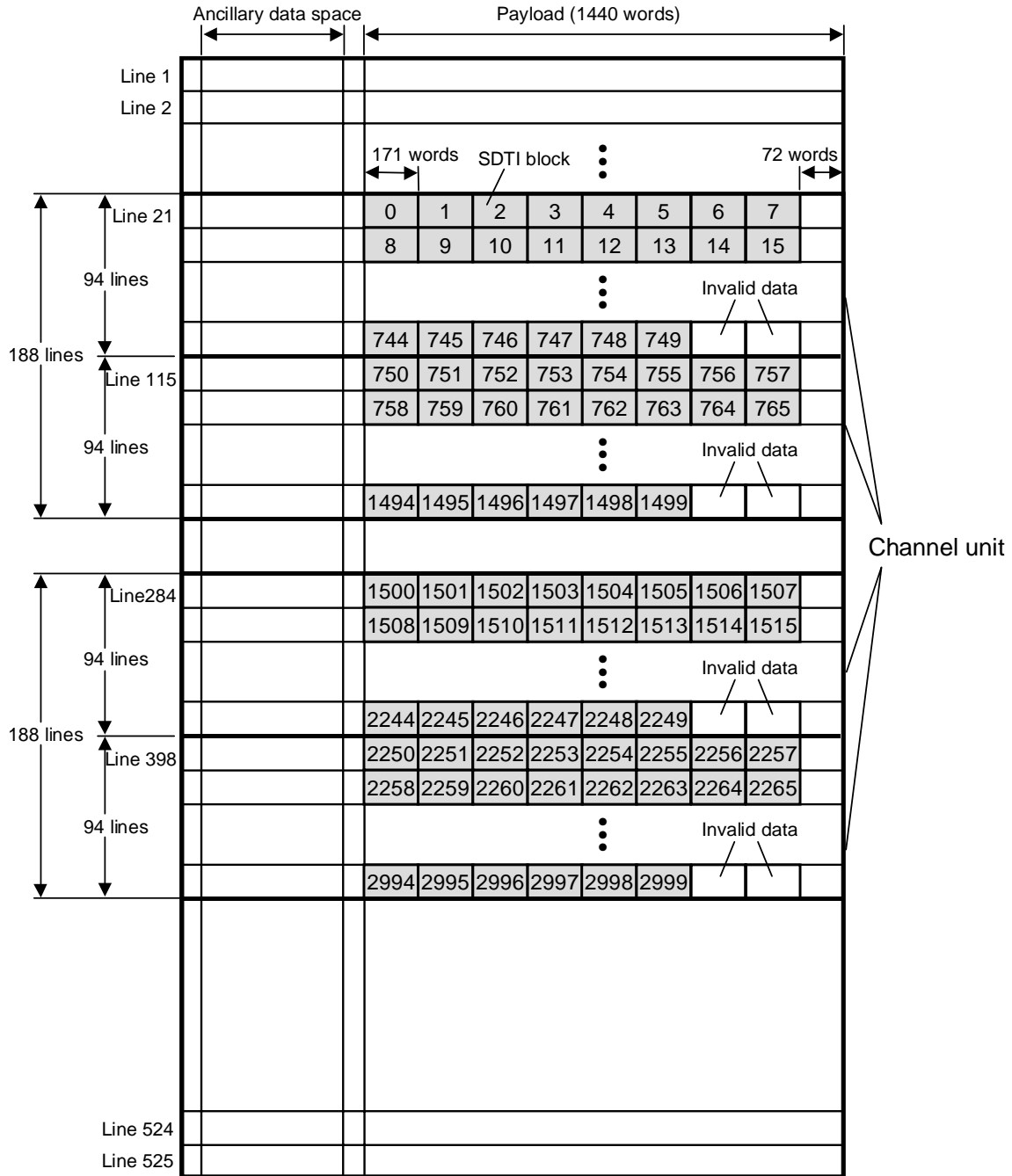

a) for 270 Mb/s system

Figure 16a – Channel unit mapping for the 100-Mb/s structure (525/60 SDTI system)

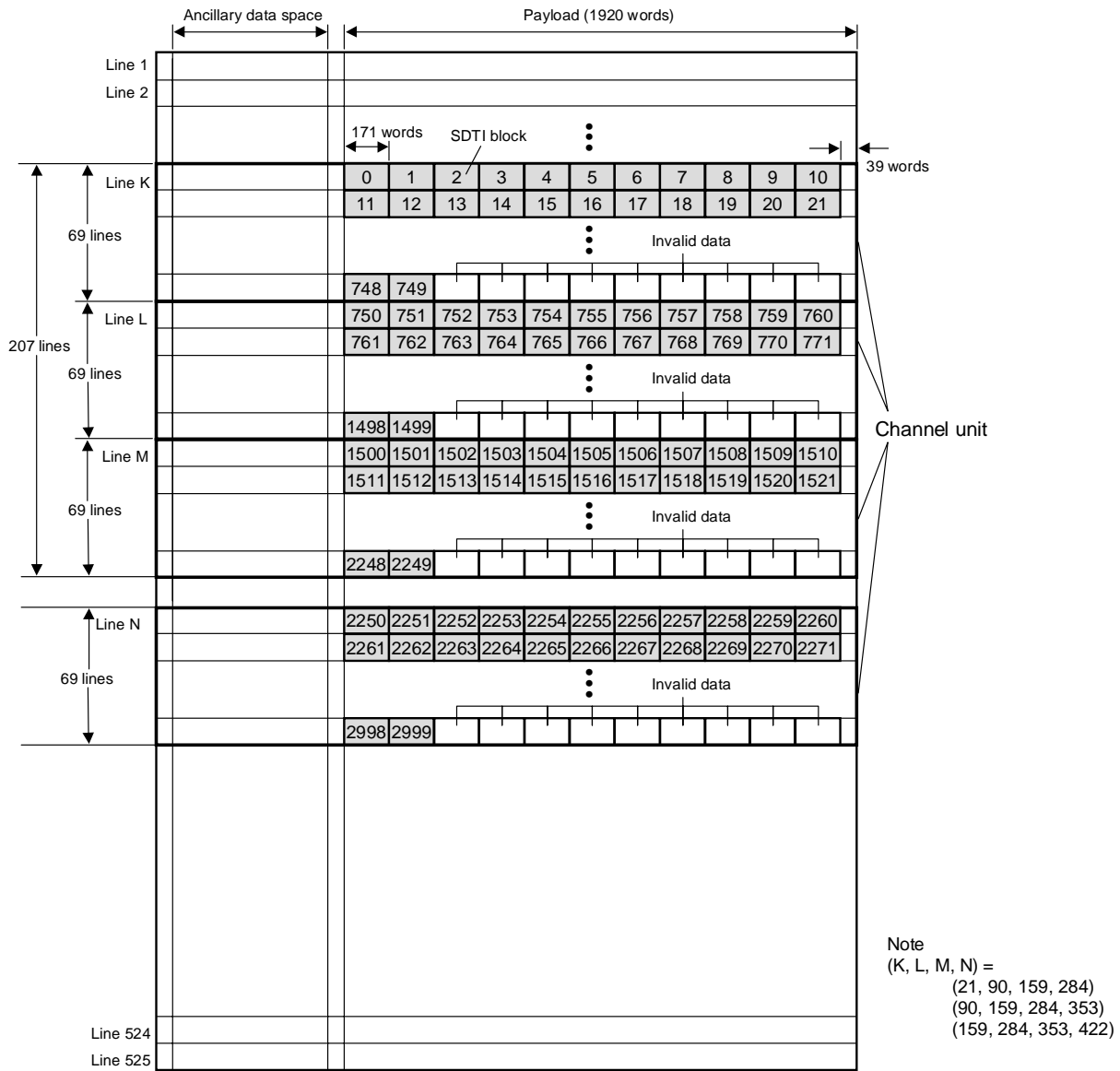

b) for 360 Mb/s system

Figure 16b – Channel unit mapping for the 100-Mb/s structure (525/60 SDTI system)

SMPTE 321M-2002

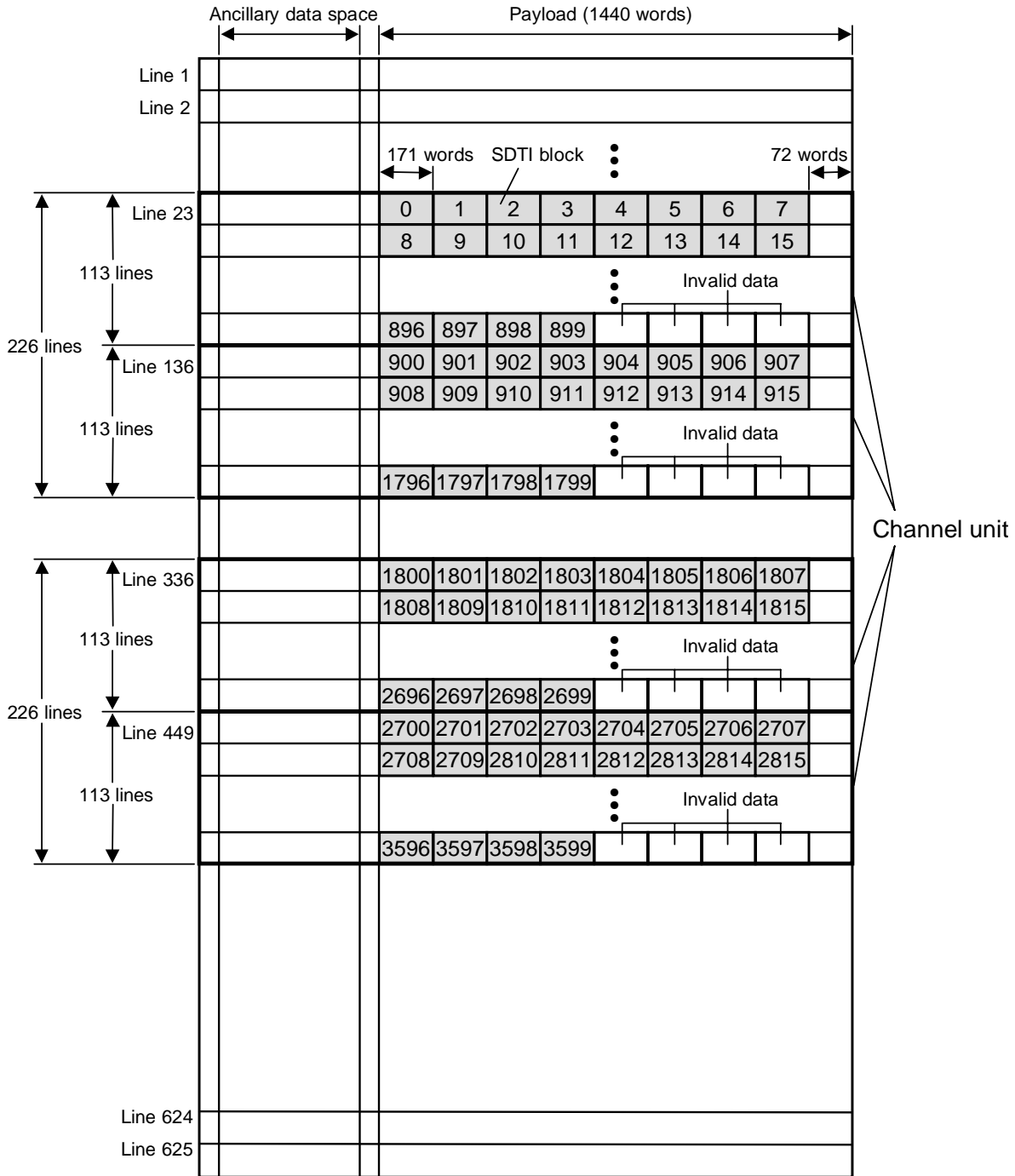

a) for 270 Mb/s system

Figure 17a – Channel unit mapping for the 100-Mb/s structure (625/50 SDTI system)



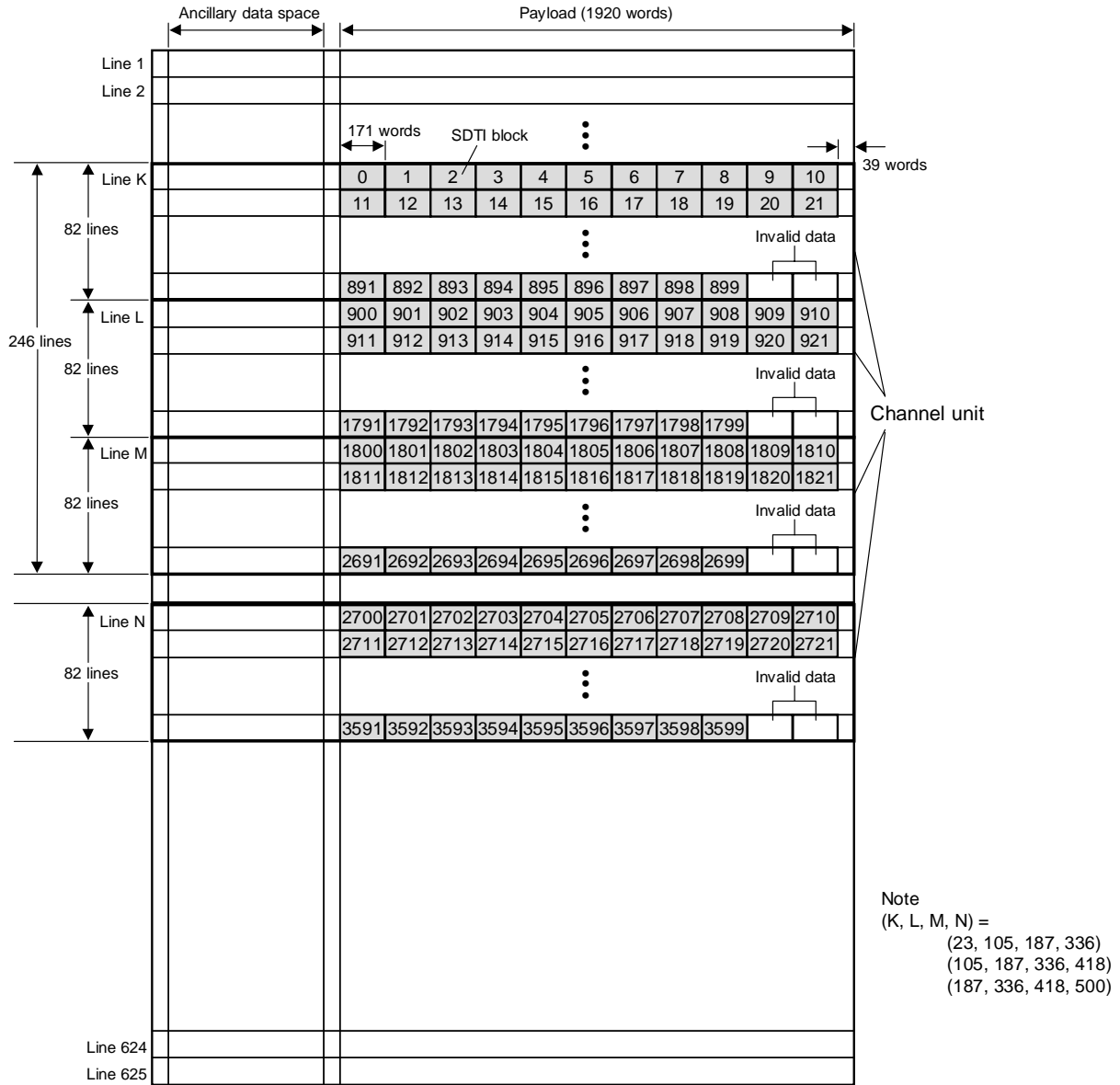

b) for 360 Mb/s system

Figure 17b – Channel unit mapping for the 100-Mb/s structure (625/50 SDTI system)

SMPTE 321M-2002

### Annex A (informative)

#### Abbreviations and acronyms

SDI:	Serial digital interface
SDTI:	Serial data transport interface
ECC:	Error correction code
DIF:	Digital interface
ST:	Signal type
STVF:	Signal type of video frame
FF:	Field/frame frequency flag
DVF:	DIF valid flag
FSNF:	Frame sequence number flag
TRF:	Transmission rate flag
TT:	Transmission type

### Annex B (informative)

#### Bibliography

ANSI/SMPTE 125M-1995, Television — Component Video Signal 4:2:2 — Bit-Parallel Digital Interface

ANSI/SMPTE 244M-1995, Television — System M/NTSC Composite Video Signals — Bit-Parallel Digital Interface

ANSI/SMPTE 259M-1997, Television — 10-Bit 4:2:2 Component and  $4f_{sc}$  Composite Digital Signals — Serial Digital Interface

ANSI/SMPTE 267M-1995, Television — Bit-Parallel Digital Interface — Component Video Signal 4:2:2 16×9 Aspect Ratio

SMPTE 291M-1998, Television — Ancillary Data Packet and Space Formatting

SMPTE 294M-2001, Television — 720 × 483 Active Line at 59.94-Hz Progressive Scan Production — Bit-Serial Interfaces

SMPTE 306M-2002, Television Digital Recording — 6.35-mm Type D-7 Component Format — Video Compression at 25 Mb/s and 50 Mb/s — 525/60 and 625/50

SMPTE 316M-1999, Television Digital Recording — 12.65-mm Type D-9 Component Format — Video Compression — 525/60 and 625/50

SMPTE 322M-1999, Television — Format for Transmission of DV Compressed Video, Audio and Data Over a Serial Data Transport Interface

IEC 61834-1 (1998-08), Recording — Helical-Scan Digital Video Cassette Recording System Using 6,35 mm Magnetic Tape for Consumer Use (525-60, 625-50, 1125-60 and 1250-50 Systems) — Part 1: General Specifications

IEC 61834-2 (1998-08), Recording — Helical-Scan Digital Video Cassette Recording System Using 6,35 mm Magnetic Tape for Consumer Use (525-60, 625-50, 1125-60 and 1250-50 Systems) — Part 2: SD Format for 525-60 and 625-50 Systems

# SMPTE STANDARD

**SMPTE 296M-2001**

Revision of  
ANSI/SMPTE 296M-1997

## for Television — 1280 × 720 Progressive Image Sample Structure — Analog and Digital Representation and Analog Interface



Page 1 of 14 pages

### Contents

- 1 Scope
- 2 Normative references
- 3 General
- 4 Timing
- 5 System colorimetry
- 6 Raster structure
- 7 Digital representation
- 8 Digital timing reference sequences (SAV, EAV)
- 9 Ancillary data
- 10 Bit-parallel interface
- 11 Analog sync
- 12 Analog interface
- Annex A Production aperture
- Annex B Pre- and post-filtering characteristics
- Annex C Bibliography

### 1 Scope

1.1 This standard defines a family of progressive image sample systems for the representation of stationary or moving two-dimensional images sampled temporally at a constant frame rate and having an image format of 1280 pixels by 720 lines and an aspect ratio of 16:9 as given in table 1. All systems in the table have the common characteristic that all the samples gathered within a single temporal unit, a frame, shall be spatially contiguous and provide a complete description of that frame (4.2) This standard specifies:

- R'G'B' color encoding;
- R'G'B' analog and digital representation;
- Y'P'B<sub>P</sub>R color encoding, analog representation, and analog interface; and
- Y'C<sub>B</sub>C<sub>R</sub> color encoding and digital representation.

**Table 1 – Image sampling systems**

	System nomenclature	Luma or R'G'B' samples per active line (S/AL)	Active lines per frame (AL/F)	Frame rate, Hz	Luma or R'G'B' sampling frequency (fs), MHz	Luma sample periods per total line (S/TL)	Total lines per frame
1	1280 × 720/60	1280	720	60	74.25	1650	750
2	1280 × 720/59.94	1280	720	60/1.001	74.25/1.001	1650	750
3	1280 × 720/50	1280	720	50	74.25	1980	750
4	1280 × 720/30	1280	720	30	74.25	3300	750
5	1280 × 720/29.97	1280	720	30/1.001	74.25/1.001	3300	750
6	1280 × 720/25	1280	720	25	74.25	3960	750
7	1280 × 720/24	1280	720	24	74.25	4125	750
8	1280 × 720/23.98	1280	720	24/1.001	74.25/1.001	4125	750

NOTE – For systems 4 through 8, analog video interface is not preferred. See clause 12.

## SMPTE 296M-2001

Designers should be aware that serial digital interfaces for formats other than Y'C'B'C'R have not been defined.

A bit-parallel digital interface is incorporated by reference in clause 10.

NOTE – Throughout this standard, references to signals represented by a single primed letter (e.g., R', G', and B') are equivalent to the nomenclature in earlier documents of the form E<sub>R'</sub>, E<sub>G'</sub>, and E<sub>B'</sub>, which in turn refer to signals to which the transfer characteristics in 5.4 have been applied. Such signals are commonly described as being gamma corrected.

**1.2** This standard specifies multiple system formats (table 1). It is not necessary for an implementation to support all formats to be compliant with this standard. However, an implementation must state which of the system formats are supported.

## 2 Normative references

The following standards contain provisions which, through reference in this text, constitute provisions of this standard. At the time of publication, the editions indicated were valid. All standards are subject to revision, and parties to agreements based on this standard are encouraged to investigate the possibility of applying the most recent edition of the standards listed below.

SMPTE 274M-1998, Television — 1920 × 1080 Scanning and Analog and Parallel Digital Interfaces for Multiple Picture Rates

SMPTE 291M-1998, Television — Ancillary Data Packet and Space Formatting

SMPTE RP 160-1997, Three-Channel Parallel Analog Component High-Definition Video Interface

SMPTE RP 177-1993 (R1997), Derivation of Basic Television Color Equations

CIE Publication 15.2 (1986), Colorimetry, Second Edition

IEC 60169-8 (1978-01), Radio Frequency Connectors, Part 8: R.F. Coaxial Connectors with Inner Diameter of Outer Conductor 6.5 mm (0.256 in) with Bayonet Lock — Characteristic Impedance 50 Ohms (Type BNC) plus amendments IEC 60169-8-am1 (1996-03) and IEC 60169-8-am2 (1997-11)

ITU-R BT.709-4 (09/00), Parameter Values for the HDTV Standards for Production and International Programme Exchange

## 3 General

**3.1** The specification of a system claiming compliance with this standard shall state:

- which of the systems of table 1 are implemented;

- which of the analog R'G'B' or Y'P'B'P'R and/or which of the digital R'G'B' or Y'C'B'C'R interfaces are implemented; and

- whether the digital representation employs eight bits or 10 bits per sample in its uniformly quantized (linear) PCM coding.

**3.2** Digital codeword values in this standard are expressed as decimal values in the 10-bit representation. An eight-bit system shall either round or truncate to the most significant eight bits as specified in 7.10.

## 4 Timing

**4.1** Timing shall be based on a reference clock of the sampling frequency indicated in table 1, which shall be maintained to a tolerance of ± 10 ppm.

**4.2** A frame shall comprise the indicated total lines per frame, each line of equal duration as determined by the sampling frequency (fs) and the samples per total line (S/TL). Samples may be obtained in an optoelectronic conversion process sequentially, simultaneously, or via a combination of both, provided all samples in the frame are contiguous in the image and obtained within the same temporal frame period. The samples within each line shall be uniformly delivered to and collected from the interface in a spatially left-to-right sequence; lines in a frame shall be uniformly delivered to and collected from the interface in a spatially top-to-bottom sequence. Lines are numbered in time sequence according to the raster structure described in clause 6.

**4.3** Timing instants in each line shall be defined with respect to a horizontal datum denoted by 0<sub>H</sub> which is established by horizontal synchronizing (sync) information in clauses 8 and 11. Each line shall be

divided into a number of reference clock intervals, of equal duration, as specified by the column S/TL in table 1. The time between any two adjacent sample instants is called the reference clock interval T.  $T = 1/fs$ .

## 5 System colorimetry

**5.1** Equipment shall be designed in accordance with the colorimetric analysis and optoelectronic transfer function defined in this clause. This corresponds to ITU-R BT.709.

**5.2** Picture information shall be linearly represented by red, green, and blue tristimulus values (RGB), lying in the range 0 (reference black) to 1 (reference white), whose colorimetric attributes are based upon reference primaries with the following chromaticity coordinates, in conformance with ITU-R BT.709, and whose white reference conforms to CIE D<sub>65</sub> as defined by CIE 15.2:

	CIE <i>x</i>	CIE <i>y</i>
Red primary	0.640	0.330
Green primary	0.300	0.600
Blue primary	0.150	0.060
Reference white	0.3127	0.3290

**5.3** From the red, green, and blue tristimulus values, three nonlinear primary components, R', G', and B', shall be computed according to the optoelectronic transfer function of ITU-R BT.709, where L denotes a tristimulus value and V' denotes a nonlinear primary signal:

$$V' = \begin{cases} 4.5L, & 0 \leq L < 0.018 \\ 1.099L^{0.45} - 0.099, & 0.018 \leq L \leq 1.0 \end{cases}$$

**5.4** To ensure the proper interchange of picture information between analog and digital representations, signal levels shall be completely contained in the range specified between reference black and reference white specified in 7.6 and 12.4, except for overshoots and undershoots due to processing.

**5.5** The Y' component shall be computed as a weighted sum of nonlinear R'G'B' primary components, using coefficients calculated from the reference primaries according to the method of SMPTE RP 177:

$$Y' = 0.2126R' + 0.7152G' + 0.0722B'$$

NOTE – Because the Y' component is computed from nonlinear R'G'B' primary components rather than from the linear tristimulus RGB values, it does not represent the true luminance value of the signal, but only an approximation. To distinguish it from luminance, the term luma is used for the Y' signal. For more information, see e.g. Poynton, *A Technical Introduction to Digital Video*.

**5.6** Color-difference component signals P'B and P'R, having the same excursion as the Y' component, shall be computed as follows:

$$P'B = \frac{0.5}{1 - 0.0722} (B' - Y')$$

$$P'R = \frac{0.5}{1 - 0.2126} (R' - Y')$$

P'B and P'R are filtered and may be coded as C'B and C'R components for digital transmission. Example filter templates are given in figure B.2.

## 6 Raster structure

**6.1** For details of vertical timing, see figures 1 and 2.

**6.2** In a system according to this standard, each frame shall comprise 750 lines including:

- Vertical blanking: lines 1 through 25 inclusive (including vertical sync, lines 1 through 5 inclusive) and lines 746 through 750 inclusive; and

- Picture: 720 lines, lines 26 through 745 inclusive.

**6.3** Ancillary signals, as distinct from ancillary data, may be conveyed during vertical blanking, lines 7 through 25 inclusive. The portion within each of these lines that may be used for ancillary data is defined in 9.3. Ancillary signals shall not convey picture information although they may be employed to convey other related or unrelated signals, coded similarly to picture information. Further specification of ancillary signals is outside the scope of this standard.

**6.4** During time intervals not otherwise used, the R', G', B' or Y', P'B, C'B, P'R, and C'R components shall have a blanking level corresponding to zero.

**6.5** The production aperture defines a region 1280 samples by 720 lines. The horizontal extent of the production aperture shall have the

SMPTE 296M-2001

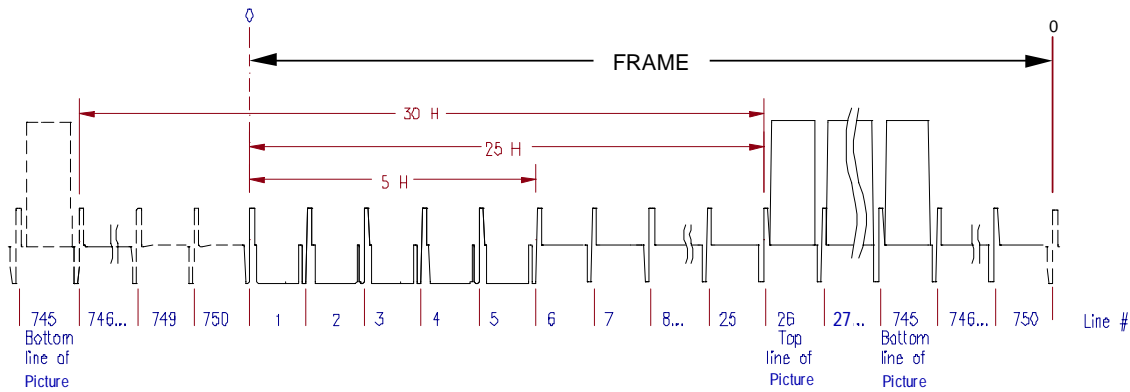

Figure 1 – Vertical timing (analog representation)

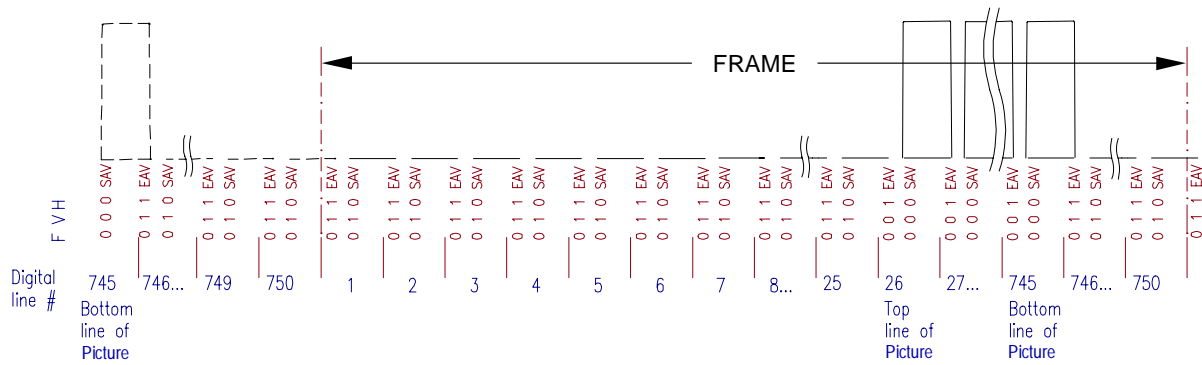

Figure 2 – Vertical timing (digital representation)

50% point of its leading transition at reference luma sample 0 and the 50% point of its trailing transition at luma sample 1279. The production aperture defines the maximum extent of picture information. For further information, consult annex A.

**6.6** The aspect ratio of the image represented by the production aperture shall be 16:9. The sample aspect ratio is 1:1 (square pixels).

**6.7** The center of the picture shall be located at the center of the production aperture, midway between samples 639 and 640, and midway between lines 385 and 386.

**6.8** Each edge of the picture width, measured at the 50% amplitude point, shall lie within six reference clock intervals of the production aperture.

## 7 Digital representation

**7.1** Digital representation shall employ either R'G'B' or Y'C<sub>B</sub>C<sub>R</sub> components, as defined in clause 5 or clause 6, uniformly sampled.

NOTE – Each component is prepared as an individual channel. Combinations of channels may be presented to an appropriate interface for signal interchange. For example, the Y' channel and the multiplexed C<sub>B</sub>/C<sub>R</sub> channel data together comprise a source format for the serial interface specified in SMPTE 292M.

**7.2** The digital signals described here are assumed to have been filtered to reduce or prevent aliasing upon sampling. For information regarding filtering, consult annex B.

**7.3** The characteristics of the digital signals are based on the assumption that the location of any required sin(x)/x correction is at the point where the signal is converted to an analog format.

**7.4** R'G'B' signals and the Y' signal of the Y'C'B'C'R interface shall be sampled orthogonally, line- and picture-repetitive, at the sampling frequency,  $f_s$ . The period of the sampling clock shall be denoted T. R'G'B' samples shall be cosited with each other.

**7.5** A luma sampling number in a line is denoted in this standard by a number from 0 through one less than the total number of samples in a line. Luma sample number zero shall correspond to the first active video sample. The luma sample numbering is shown in figure 3. Note that the distance between 0<sub>H</sub> and the start of SAV is 256 samples.

NOTE – The active video digital representation is 1280 clock periods (0-1279) in length.

**7.6** Digital R', G', B', and Y' components shall be computed as follows:

$$L'_D = \text{Floor}(219DL' + 16D + 0.5); D = 2^{n-8}$$

where L' is the component value in abstract terms from zero to unity, n takes the value 8 or 10 corresponding to the number of bits to be represented, and L'<sub>D</sub> is the resulting digital code. The unary function Floor yields the largest integer not greater than its argument.

NOTE – This scaling places the extrema of R', G', B', and Y' components at codewords 64 and 940 in a 10-bit representation or codewords 16 and 235 in an eight-bit representation.

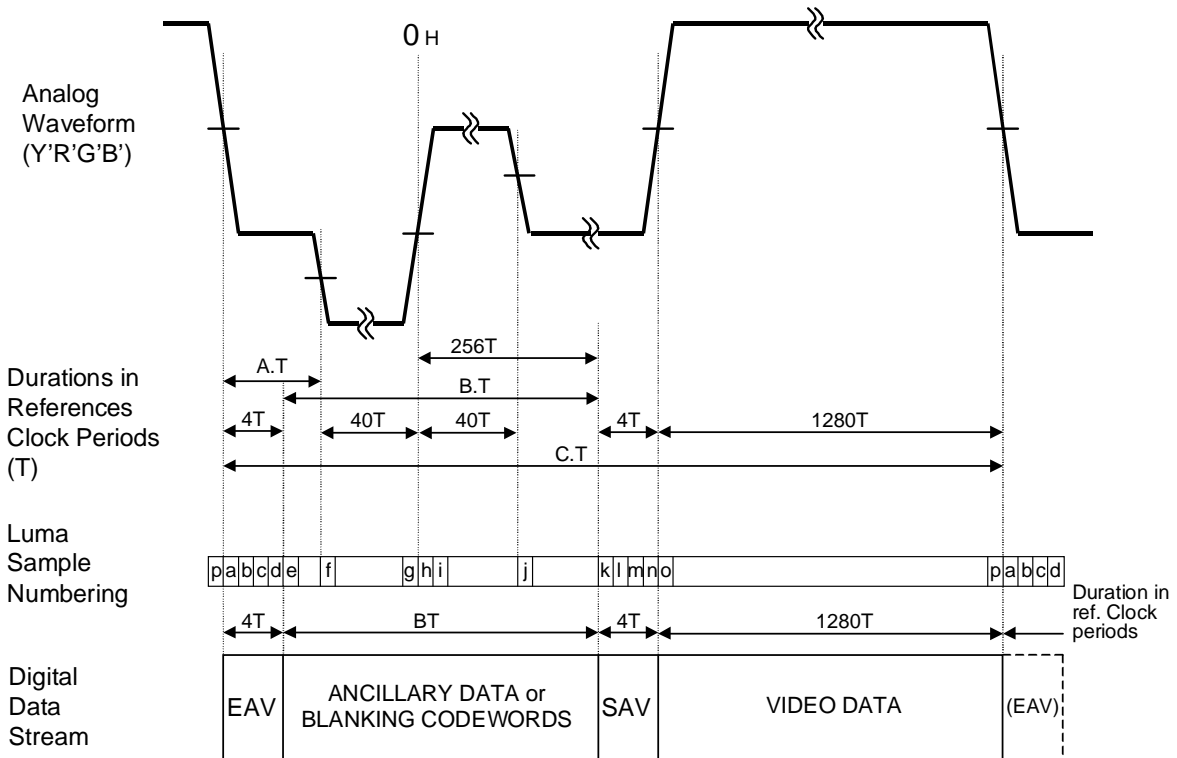

- NOTES
- 1 Horizontal axis not to scale.
  - 2  $0_H$  is the analog horizontal timing reference point, and in the analog domain, is regarded as the start of the line.
  - 3 A line of digital video extends from the first word of EAV to the last word of video data.

Figure 3 – Analog and digital timing relationships

## SMPTE 296M-2001

**7.7** Digital  $C'_B$  and  $C'_R$  components of the  $Y'C'_BC'_R$  set shall be computed as follows:

$$C'_D = \text{Floor}(224DC' + 128D + 0.5); D = 2^{n-8}$$

where  $C'$  is the component value in abstract terms from  $-0.5$  to  $+0.5$ , and  $C'_D$  is the resulting digital code. The unary function Floor yields the largest integer not greater than its argument.

NOTE – This scaling places the extrema of  $C'_B$  and  $C'_R$  at codewords 64 and 960 in a 10-bit representation or codewords 16 and 240 in an eight-bit representation.

**7.8**  $C'_B$  and  $C'_R$  signals shall be horizontally subsampled by a factor of two with respect to the  $Y'$  component.  $C'_B$  and  $C'_R$  samples shall be cosited with even-numbered  $Y'$  samples. The sample number zero of  $C'_B$  and  $C'_R$  corresponds to the first active video 0 sample. For information regarding filtering, consult annex B.

The subsampled  $C'_B$  and  $C'_R$  signals shall be time-multiplexed on a sample basis, in the order  $C'_BC'_R$ . The first data word of an active line shall be a  $C'_B$  sample. The multiplexed signal is referred to as  $C'_B/C'_R$ .

NOTE – Systems 7 and 8 have 2063  $C'_B$  sample periods and 2062  $C'_R$  sample periods per line. The  $C'_B/C'_R$  multiplexer must be reset every line at sample number zero.

**7.9** Code values having the eight most significant bits all zero or all one — that is, 10-bit codes 0, 1, 2, 3, 1020, 1021, 1022, and 1023 — are employed for synchronizing purposes and shall be prohibited from video, ancillary signals, and ancillary data.

**7.10** A system having an eight-bit interface shall address the conversion of 10-bit video data to eight bits with an appropriate process that minimizes video artifacts such as quantization noise. Ancillary data in 10-bit format shall be converted to eight-bit format by truncating the two least significant bits. In both cases, when converting eight-bit data to 10-bit data, the two least significant bits of the 10-bit word shall be set to 0.

NOTE – SMPTE is addressing rounding for all eight-bit/10-bit digital video standards. SMPTE 291M describes the

handling of ancillary data between eight-bit and 10-bit interfaces in annex D.

**7.11** For  $Y'$ ,  $R'$ ,  $G'$ , and  $B'$  signals, undershoot and overshoot in video processing may be accommodated by the use of codewords 4 through 63 and codewords 941 through 1019 in a 10-bit system, or codewords 1 through 15 and codewords 236 through 254 in an eight-bit system.

For  $C'_B$  and  $C'_R$  signals, undershoot and overshoot in video processing may be accommodated by the use of codewords 4 through 63 and codewords 961 through 1019 in a 10-bit system, or codewords 1 through 15 and codewords 241 through 254 in an eight-bit system.

## 8 Digital timing reference sequences (SAV, EAV)

**8.1** SAV (start of active video) and EAV (end of active video) digital synchronizing sequences shall define synchronization across the digital interface. Figures 2, 3, and 4 show the relationship of the SAV and EAV sequences to digital and analog video.

**8.2** An SAV or EAV sequence shall comprise four consecutive codewords: a codeword of all ones, a codeword of all zeros, another codeword of all zeros, and a codeword including F (frame), V (vertical), H (horizontal), P3, P2, P1, and P0 (parity) bits. An SAV sequence shall be identified by having  $H = 0$ ; EAV shall have  $H = 1$  (tables 3 and 4 show details of the coding).

**8.3** When digitized, every line shall include a four-sample EAV sequence commencing 110 clocks prior to  $0_H$  (for systems 1 and 2); 440 clocks prior to  $0_H$  (for system 3); 1760 clocks prior to  $0_H$  (for systems 4 and 5); 2420 clocks prior to  $0_H$  (for system 6); and 2585 clocks prior to  $0_H$  (for systems 7 and 8). When digitized, every line shall include a four-sample SAV sequence commencing 256 clocks after  $0_H$  (for all systems [1, 2, 3, 4, 5, 6, 7, and 8]). The EAV sequence immediately preceding the  $0_H$  datum of line 1 shall be considered to be the start of the digital frame as shown in figure 2.



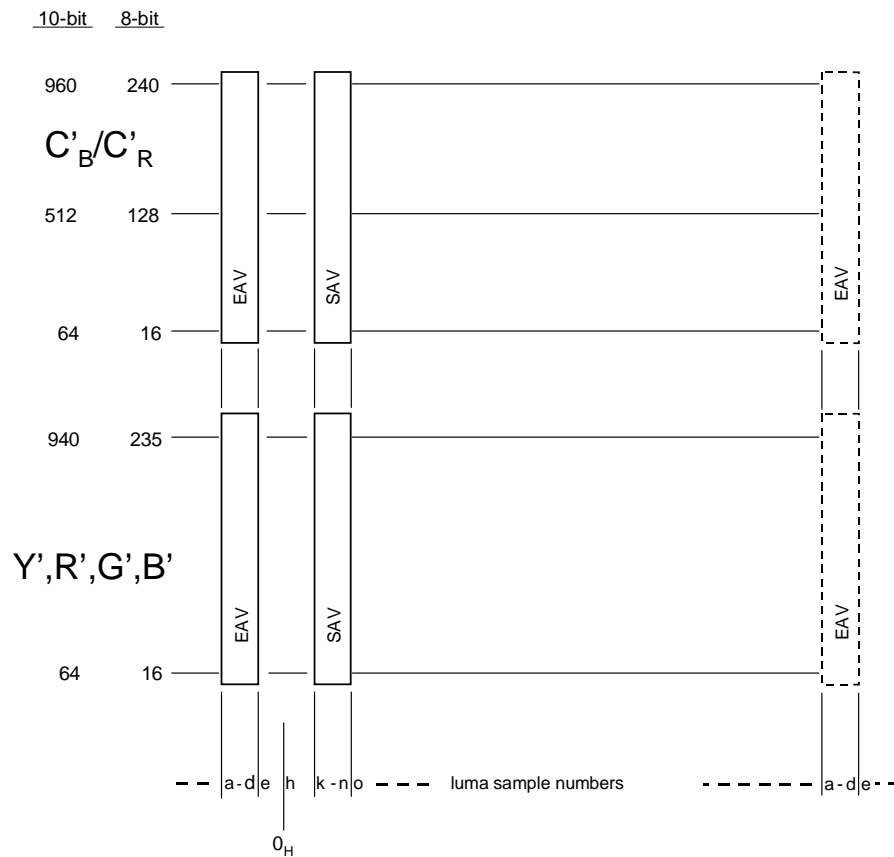

NOTES

- 1 Figure 3/table 2 show numbering of luma sample numbers for each of the systems covered in this standard.
- 2  $0_H$  is the analog horizontal timing reference point.

Figure 4 – Digital representation — Horizontal timing details

Table 2 – Values for figures 3 and 4 and table 5 for different systems

Systems	Luma sample numbering															
	a	b	c	d	e	f	g	h	i	j	k	l	m	n	o	p
1,2	1280	1281	1282	1283	1284	1350	1389	1390	1391	1430	1646	1647	1648	1649	0	1279
3	1280	1281	1282	1283	1284	1680	1719	1720	1721	1760	1976	1977	1978	1979	0	1279
4,5	1280	1281	1282	1283	1284	3000	3039	3040	3041	3080	3296	3297	3298	3299	0	1279
6	1280	1281	1282	1283	1284	3660	3699	3700	3701	3740	3956	3957	3958	3959	0	1279
7,8	1280	1281	1282	1283	1284	3825	3864	3865	3866	3905	4121	4122	4123	4124	0	1279
System	Duration in reference clock periods (T)															
	A			B			C									
1,2	70			362			1650									
3	400			692			1980									
4,5	1720			2012			3300									
6	2380			2672			3960									
7,8	2545			2837			4125									

NOTE – Figure 3 and table 2 representations show nominal relationship values between the analog and digital representations. See figure 5 and table 5 for tolerance values for the analog sync including rise and fall tolerances.

SMPTE 296M-2001

Table 3 – Video timing reference codes

Bit number		9 (MSB)	8	7	6	5	4	3	2	1	0 (LSB)
Word	Value										
0	1023	1	1	1	1	1	1	1	1	1	1
1	0	0	0	0	0	0	0	0	0	0	0
2	0	0	0	0	0	0	0	0	0	0	0
3		1	F	V	H	P3	P2	P1	P0	0	0

Table 4 – Protection bits for SAV and EAV

Bit number		9	8	7	6	5	4	3	2	1	0
Function		1 Fixed	F	V	H	P3	P2	P1	P0	0 Fixed	0 Fixed
Value of (F/V/H)	0	1	0	0	0	0	0	0	0	0	0
	1	1	0	0	1	1	1	0	1	0	0
	2	1	0	1	0	1	0	1	1	0	0
	3	1	0	1	1	0	1	1	0	0	0

#### 8.4 F/V/H flags

- The EAV and SAV of all lines shall have F = 0.
- The EAV and SAV of lines 1 through 25 inclusive and lines 746 through 750 inclusive shall have V = 1.
- The EAV and SAV of lines 26 through 745 inclusive shall have V = 0.
- The EAV of line 1 shall be considered the start of the digital frame.

**8.5** A line which in the analog representation is permitted to convey ancillary signals may convey digitized ancillary signals.

### 9 Ancillary data

**9.1** Ancillary data may optionally be included in the blanking intervals of a digital interface according to this standard.

**9.2** The interval between the end of EAV and the start of SAV may be employed to convey ancillary data packets. Designers should be aware that when SMPTE 292M serial interface

is employed, the first four samples after EAV are reserved for other usage.

**9.3** The interval between the end of SAV and the start of EAV of any line that is outside the vertical extent of the picture (as defined in clause 6.2), and that is not employed to convey digitized ancillary signals, may be employed to convey ancillary data packets.

NOTE – Currently SMPTE is defining the switching point(s) for all serial digital video interfaces. The reader is cautioned to be aware that ancillary data should be placed taking into account the switching point.

**9.4** Ancillary data packets may be conveyed across each of the three R', G', and B' channels, or across each of the three Y', C'B/C'R channels.

**9.5** In the case of 10-bit representation, intervals not used to convey SAV, video data, EAV, ancillary signals, or ancillary data shall convey the codeword 64 (black) in the R', G', B', Y' channels, or 512 in the C'B/C'R channels. They shall be 16 and 128, respectively, in the case of 8-bit representation.

9.6 For specifications of the details of ancillary data, see SMPTE 291M.

**10 Bit-parallel interface**

The electrical and mechanical parameters of the bit-parallel interface are specified in clauses 10, 11, 12, and 13 of SMPTE 274M, which are incorporated by reference. It is anticipated that in future revisions of SMPTE 274M that auxiliary component A will be eliminated.

**11 Analog sync**

11.1 Details of analog sync timing are shown in figures 1, 3, and 5 and are summarized in table 5.

11.2 A positive zero-crossing of a trilevel sync pulse shall define the  $0_H$  datum for each line. A negative-going transition precedes this instant by 40 reference clock intervals, and another negative-going transition follows this instant by 40 reference clock intervals.

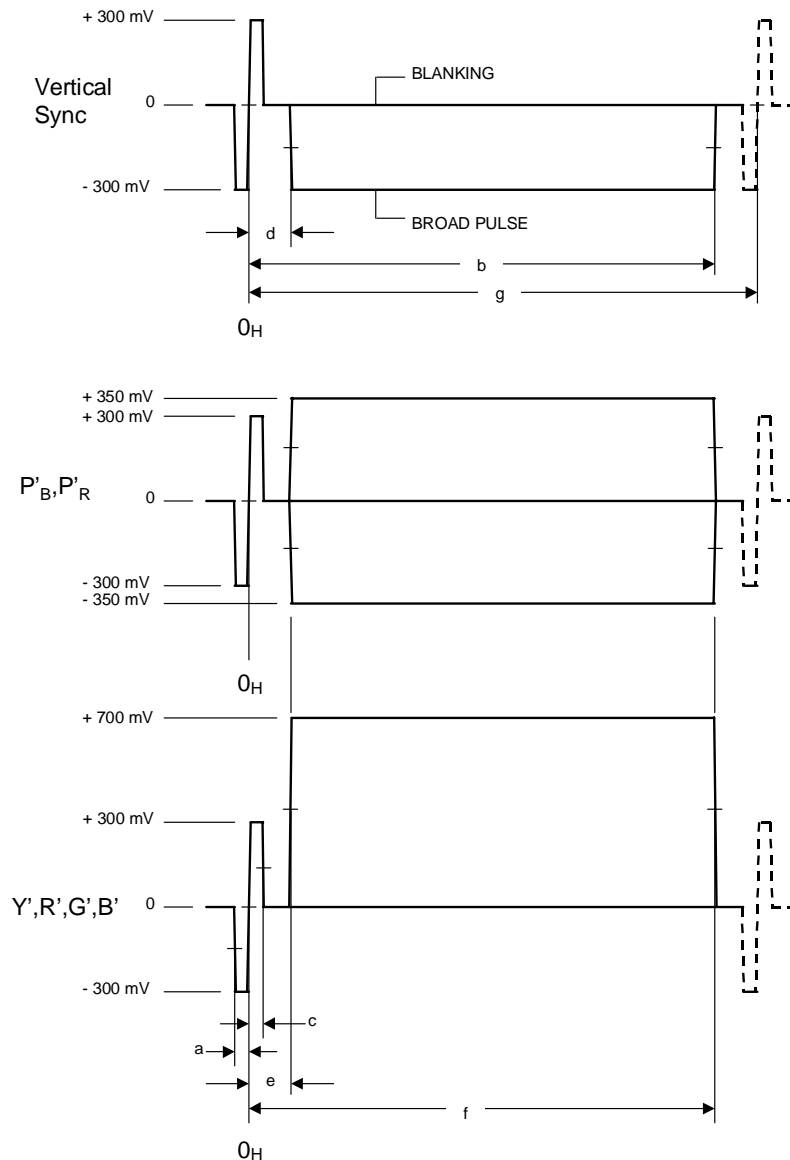

Figure 5 – Analog levels and timing

SMPTE 296M-2001

**Table 5 – Analog sync timing  
(Systems 1 - 8)**

		Duration (T)	Tolerance (T)
a	See figure 5	40	$\pm 3$
b	See figure 5	1540	$- 6$ $+ 0$
c	See figure 5	40	$\pm 3$
d	See figure 5	260	$- 0$ $+ 6$
e	See figure 5	260	$- 0$ $+ 6$
f	See figure 5	1540	$- 6$ $+ 0$
	Sync rise and fall time	4	$\pm 1.5$
g	Total line	Table 2 'C'	
	Active line	1280	$- 12$ $+ 0$

**11.3** Positive transition of a trilevel sync pulse shall be skew-symmetric with a rise time from 10% to 90% of  $4 \pm 1.5$  reference clock periods. The 50% (midpoint) point of each negative transition shall be coincident with its ideal time within a tolerance of  $\pm 3$  reference clock periods.

**11.4** The trilevel sync pulse shall have structure and timing according to figures 3 and 5. The positive peak of the trilevel sync pulse shall have a level of  $+300 \text{ mV} \pm 6 \text{ mV}$ ; its negative peak shall have a level of  $-300 \text{ mV} \pm 6 \text{ mV}$ . The amplitude difference between positive and negative sync peaks shall be less than 6 mV.

**11.5** Each line that includes a vertical sync pulse shall maintain blanking level, here denoted zero, except for the interval(s) occupied by sync pulses. During the horizontal blanking interval, areas not occupied by sync shall be maintained at blanking level, here denoted zero.

**11.6** Each frame shall commence with five vertical sync lines, each having a broad pulse. The leading 50% point of a broad pulse shall be 260T after the preceding trilevel zero crossing. The trailing 50% point of a broad pulse shall be 1540T after the preceding trilevel zero crossing.

## 12 Analog interface

NOTE – This clause applies to all frame rates in table 1. However, direct analog interconnection of slow-rate systems (30 Hz and below) is not preferred, except for synchronizing signals.

**12.1** An analog interface according to this standard may employ either the R'G'B' component set or the Y'P'B'P'R component set.

**12.2** R'G'B' and Y' channels shall have a nominal bandwidth of 30 MHz.

**12.3** Each component signal shall be conveyed electrically as a voltage on an unbalanced coaxial cable into a pure resistive impedance of 75  $\Omega$ .

**12.4** For the Y', R', G', and B' components, reference black (zero) in the expressions of 5.5 shall correspond to a level of 0 Vdc, and reference white (unity) shall correspond to 700 mV.

**12.5** P'B and P'R components are analog versions of the C'B and C'R components of 5.6, in which zero shall correspond to a level of 0 Vdc and reference peak level (value 0.5 of equations in 5.6) shall correspond to a level of +350 mV.

**12.6** Trilevel sync according to clause 11 shall be added to each analog component.

**12.7** Each of the electrical signals in an analog interface employs a connector that shall conform to IEC 60169-8, with the exception that the impedance of the connector may be 75  $\Omega$ , or to SMPTE RP 160.

**Annex A (informative)**  
**Production aperture**

**A.1 Production aperture**

A production aperture for the studio digital signal defines an active picture area of 1280 pixels × 720 lines as produced by signal sources such as cameras, telecines, digital video tape recorders, and computer-generated pictures conforming to this standard.

**A.2 Analog blanking tolerance**

**A.2.1** The duration of the maximum active analog video signal measured at the 50% points is standardized as 1280 clock periods. However, the analog blanking period may differ from equipment to equipment and the digital blanking may not coincide with the analog blanking in actual implementation.

**A.2.2** To maximize the active video duration in picture origination sources, it is desirable to have analog blanking match digital blanking. However, recognizing the need for reasonable tolerance in implementation, analog blanking may be wider than digital blanking (see figures 3 and 5).

**A.2.3** To accommodate a practical implementation of analog blanking within various studio equipment, a tolerance of six clock periods is provided at the start and end of active video. Accordingly, the analog tolerance to parameters b and e of table 5 are as follows:

Parameter	Definition	Nominal value (T)	Tolerance (T)
b	0H to end of active video	1540	- 6 + 0
e	0H to start of active video	260	- 0 + 6

Preferred practice is to provide a full production aperture signal at the output of an analog source prior to first digitization, reserving the tolerance for possible subsequent analog processes.

**A.2.4** The relationship of the associated analog representation (inclusive of this tolerance) with the production aperture is shown in figure 5.

**A.3 Transient regions**

**A.3.1** This standard defines a picture aspect ratio of 16:9 with 1280 pixels per active line and 720 active lines per frame. However, digital processing and associated spatial filtering can produce various forms of transient effects at picture blanking edges and within adjacent active video that should be taken into account to allow practical implementation of the studio standard.

**A.3.2** Analog transients. The following factors contribute to these effects:

- Bandwidth limitation of component analog signals (most noticeably, the ringing on color-difference signals);
- Analog filter implementation;

- Amplitude clipping of analog signals due to the finite dynamic range imposed by the quantization process;
- Use of digital blanking in repeated analog-digital-analog conversions; and
- Tolerance in analog blanking.

**A.4 Clean aperture**

**A.4.1** The bandwidth limitation of an analog signal (pre- and post-filtering) can introduce transient ringing effects which intrude into the active picture area. Also, multiple digital blanking operations in an analog-digital-analog environment can increase transient ringing effects. Furthermore, cascaded spatial filtering and/or techniques for handling the horizontal and vertical edges of the picture (associated with complex digital processing in post-production) can introduce transient disturbances at the picture boundaries, both horizontally and vertically. It is not possible to impose any bounds on the number of cascaded processes which might be encountered in the practical post-production system. Hence, recognizing the reality of those picture edge transient effects, the definition of a system design guideline is introduced in the form of a subjectively artifact-free area, called clean aperture.

**A.4.2** The clean aperture defines an area within which picture information is subjectively uncontaminated by all edge transient distortions. In order to minimize the effects on subsequent compression or transmission processes, the contaminated area should be confined within 16 pixels and 9 lines of the production aperture edges.

**A.4.3** The clean aperture of the picture defines a region 1248 samples in width by 702 lines high, symmetrically located in the production aperture. The clean aperture shall be substantially free from transient effects due to blanking and picture processing. An encroachment of 6 samples maximum on each of the left and right edges of the production aperture is allowed for horizontal blanking errors generated by analog processing. Vertical blanking shall be as specified with zero tolerance.

**A.4.4** This yields a minimum clean aperture of 1248 horizontal active pixels by 702 active lines whose quality is guaranteed for final release. The clean aperture lies within the production aperture as shown in figure A.1.

**A.4.5** It is good practice to minimize variations in analog blanking and to use techniques in digital processing that minimize or prevent transients in the allowed contaminated area as well as inside the clean aperture.

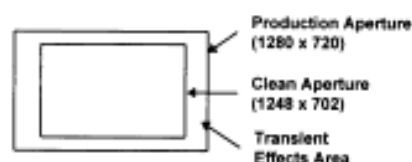

**Figure A.1 – Clean aperture**

SMPTE 296M-2001

**Annex B (informative)**  
**Pre- and post-filtering characteristics**

**B.1** Figure B.1 depicts example filter characteristics for pre- and post-filtering of Y', R', G', and B' component signals. Figure B.2 depicts example filter characteristics for pre- and post-filtering of P'B and P'R component signals.

**B.2** The passband frequency of the component Y', R', G', and B' signals is nominally 30 MHz.

**B.3** The value of the amplitude ripple tolerance in the passband is  $\pm 0.05$  dB relative to the insertion loss at 100 kHz.

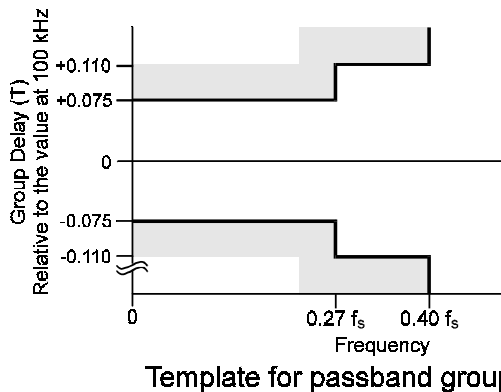
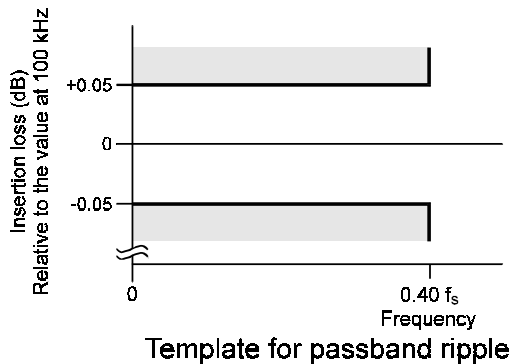
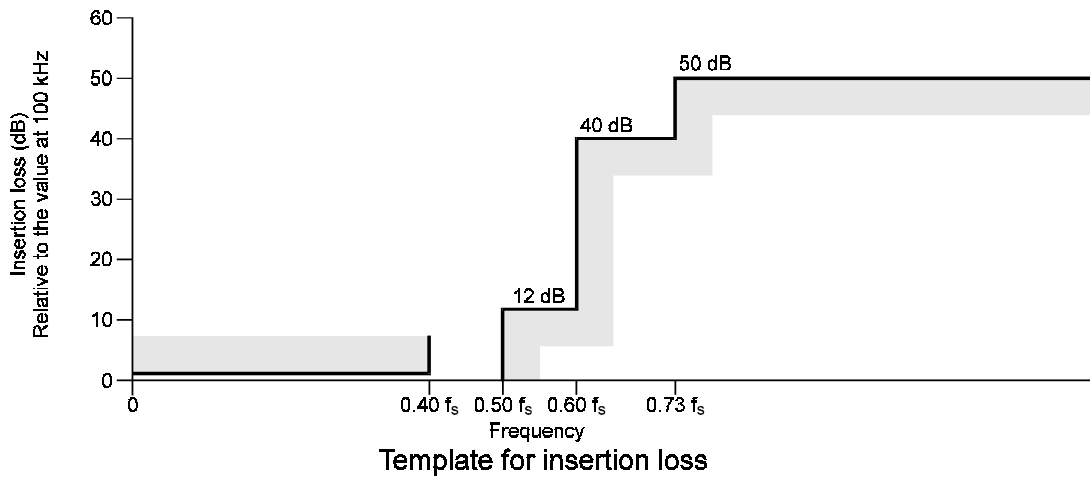

NOTE - The value of  $f_s$  is given in table 1

**Figure B.1 – Example filter template for Y' and R'G'B' components**

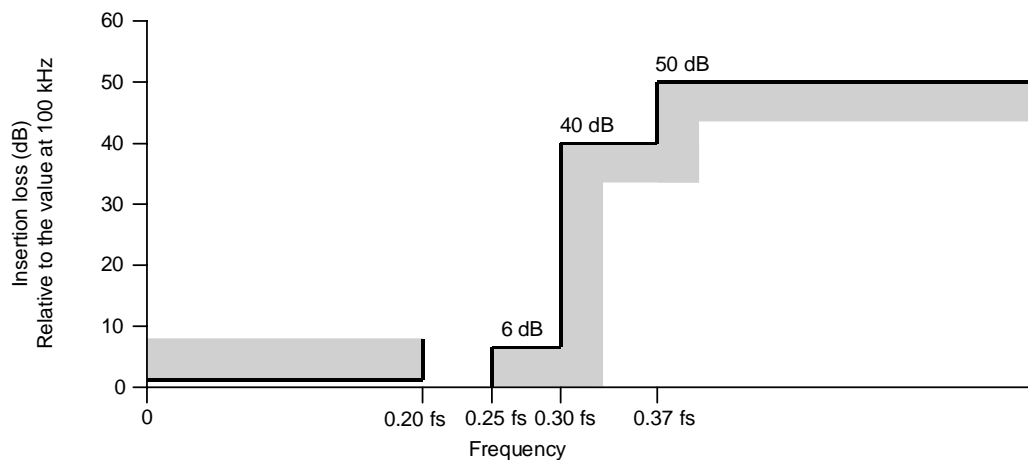

Template for insertion loss

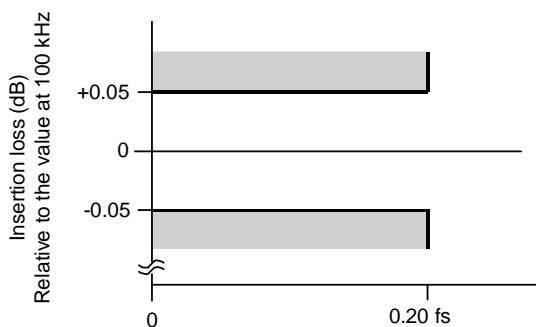

Template for passband ripple

NOTE - The value of fs is given in table 1

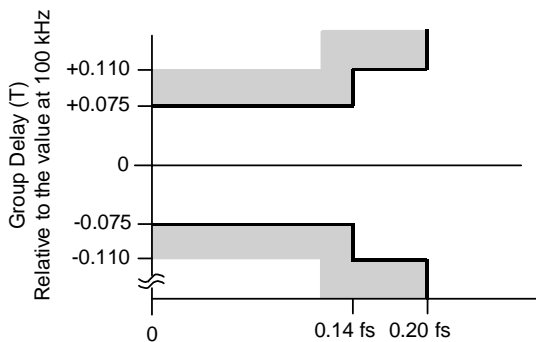

Template for passband group-delay

Figure B.2 – Example filter template for P<sub>B</sub> and P<sub>R</sub> components

**B.4** The insertion loss characteristics of the filters are frequency-scaled from the characteristics of ITU-R BT.601. Insertion loss is 12 dB or more at half the sampling frequency of the Y', R', G', and B' components, and 6 dB or more at half the sampling frequency of the P<sub>B</sub> and P<sub>R</sub> components relative to the insertion loss at 100 kHz.

**B.5** The specifications for group-delay in the filters are sufficiently tight to produce good performance while allowing the practical implementation of the filters.

SMPTE 296M-2001

**Annex C (informative)**  
**Bibliography**

SMPTE 292M-1998, Television — Bit-Serial Digital Interface for High-Definition Television Systems

ITU-R BT.601-5 (10/95), Studio Encoding Parameters of Digital Television for Standard 4:3 and Wide-Screen 16:9 Aspect Ratios

ITU-R BT.1361 (1998), Worldwide Unified Colorimetry and Related Characteristics of Future Television and Imaging Systems

Poynton, Charles. *A Technical Introduction to Digital Video*. John Wiley & Sons