

## RECOMMENDATION ITU-R BT.1379-2

**Safe areas of wide-screen 16:9 and standard 4:3 aspect ratio productions to achieve a common format during a transition period to wide-screen 16:9 broadcasting**

(1998-2001-2007)

**Scope**

This Recommendation provides guidelines on safe areas of 625-line, 1 080-line and 720-line formats of wide-screen 16:9 and standard 4:3 aspect ratio production to achieve a common format during a transition period to wide-screen 16:9 broadcasting.

The ITU Radiocommunication Assembly,

*considering*

- a) that standard definition television will in time undergo a transition from the conventional 4:3 aspect ratio to the newer wide-screen 16:9 aspect ratio;
- b) that during a transition period wide-screen 16:9 aspect ratio images will need to be broadcast in a conventional 4:3 aspect ratio service;
- c) that similarly, conventional 4:3 aspect ratio images will need to be broadcast in a new wide-screen 16:9 aspect ratio service;
- d) that although pan-scan techniques can be used to obtain a 4:3 image from one of 16:9, the technique is expensive and is difficult with live programmes;
- e) that although a 16:9 image can be displayed as a compatible letter-box on 4:3 displays, this technique is not universally accepted by all broadcasters and viewers;
- f) that although a 4:3 image can be displayed centrally within a 16:9 display, this technique may not be universally accepted by all broadcasters and viewers;
- g) that by framing for a 14:9 (shoot and protect) image, a 16:9 image can be extracted from the 4:3 source with minimal loss of important action, and similarly a 4:3 image can be extracted from a 16:9 source with minimal loss of important action;
- h) that there would be economic and practical benefits arising from the use of a single video chain capable of producing a programme suitable for transmission in either conventional 4:3 aspect ratio or enhanced 16:9 aspect ratio services;
- j) that the use of component digital 16:9 video chains will provide viewers watching 16:9 services with the optimum picture quality;
- k) that the ability to use a 16:9 chain for the transmission of a programme in 4:3 will encourage the introduction of new 16:9 equipment;
- l) that the ability to use a single master for simultaneous transmission to both digital 16:9 and analog 4:3 services would encourage the transition to 16:9 broadcasting;
- m) that wide-screen formats may include 1 080-line and 720-line as well as lower resolution,

*recommends*

- 1 that during a transition period where a standard definition electronic video chain may be required to be used for programmes intended to be suitable for simultaneous and non-simultaneous transmission in an aspect ratio of either 4:3 or 16:9, account should be taken of the need to protect the safe areas of the 14:9 central zone, either in image acquisition or post-production, according to the principles described in Annex 1;
- 2 that, in the case of programmes intended for 625-line transmission, account should be taken of the guidelines for safe areas described in Annex 2;
- 3 that, in the case of programmes intended for 1 080-line transmission, account should be taken of the guidelines for safe areas described in Annex 3;
- 4 that, in the case of programmes intended for 720-line transmission, account should be taken of the guidelines for safe areas described in Annex 4,

*further recommends*

- 5 that in these circumstances it should be desirable that 14:9 graticules are optionally available for use on viewfinders in 4:3 and 16:9 electronic cameras, including HDTV cameras;
- 6 that in these circumstances captions should be kept within the graphics safe area of the 14:9 image;
- 7 that, where available, the use of a fully component electronic production chain in the 16:9 aspect ratio should be preferred.

## Annex 1

### **Safe areas to allow a common format for 16:9 and 4:3 television programmes during a transition period to wide-screen 16:9 broadcasting**

Until such time as the 16:9 format is fully established as the norm for broadcasting, broadcasters will have to choose the aspect ratio to use for productions which have overseas potential and long shelf life, particularly drama, bearing in mind the usage of 16:9 and 4:3 television receivers and the penetration of wide-screen enhanced analog and digital services. For television production, the choice is either 4:3 (i.e. 12:9) or 16:9. The programme might be shot on video, or on Super 16 mm or 35 mm film.

Video production aspect ratio is determined by the physical dimensions of camera sensors, and in practice is either 4:3 or 16:9. For film, the Super 16 mm format has an aspect ratio of 15:9, whereas the full image area of 35 mm film is standardized for the Academy format at approximately 4:3. Film, however, can subsequently be transferred to video at almost any aspect ratio in the telecine.

A method of framing is proposed which enables producers of electronic video productions to enjoy similar flexibility to that of film producers. In the short term, this increases the amount of programme material potentially available for transmission in the 16:9 format; it also provides encouragement for programme makers to commission productions in the 16:9 format, and for existing 4:3 aspect ratio equipment to be replaced by new production chains operating in the 16:9 format.

It should be recognized that the optimum picture quality for transmission by 16:9 aspect ratio enhanced analog or digital services is obtained when the complete production chain is itself in the 16:9 format. Nevertheless, to achieve flexibility and to obtain consistency, until such time as the dominant aspect ratio for both production and transmission is 16:9, it is suggested that for electronic television production and post-production, *the major action is framed for a mean aspect ratio of 14:9*; that is, wholly contained within the source format, i.e. within 16:9 or 4:3. By this means, the production format within the television studio will be in a chosen aspect ratio of either 16:9 or 4:3. For subsequent transmission, it is a relatively simple matter to extract either 16:9 or 4:3 with minimal loss or extension to the action area.

Appendices 1 and 2 to Annex 1 illustrate how the framing can be achieved in the cases of 16:9 camera sources and 4:3 camera sources, respectively. The transfer to 14:9, if required, is part of the transmission pre-processing and the production formats within the studio will always be 16:9 or 4:3. In the case of a transfer from 16:9 to 14:9, the exact number of active lines may be chosen at the discretion of the producer. In some cases, it may be preferred to retain a full letter-box format for transmission of 16:9 programmes; producers can have the freedom to decide whether to transmit the material in 4:3 or in any compromise aspect ratio up to 16:9.

## Appendix 1 to Annex 1

14:9 framing with 16:9 camera source (figures drawn to scale)

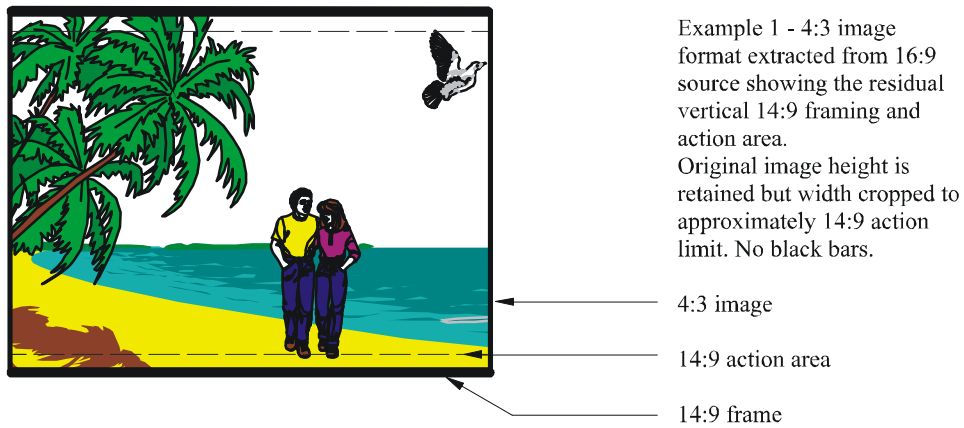
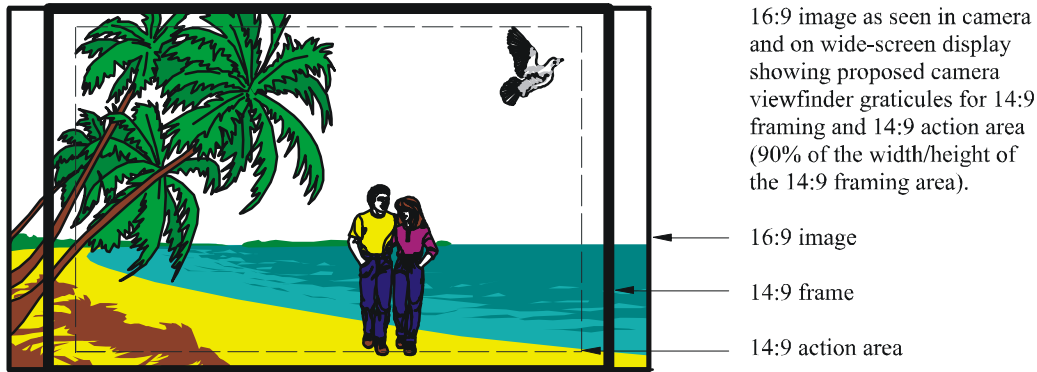

*Note 1* - Two examples are given to illustrate some of the possible options for conversion to 4:3 -

Example 1 has no black bars, Example 2 has small black bars at the top/bottom.

*Note 2* - Depending on the production format, the horizontal resolution capability of the 4:3 display might not be fully exploited.

*Note 3* - If a 625-line system is used for 16:9 production and for extraction/display in 4:3, then the 16:9 display and the 4:3 display of Example 1 have 576 active lines, while the 4:3 display in Example 2 has 494 active lines.

## Appendix 2 to Annex 1

14:9 framing with 4:3 camera source (figures drawn to scale)



4:3 image as seen in camera and on standard display showing proposed camera viewfinder graticules for 14:9 framing and 14:9 action area (90% of the width/height of the 14:9 framing area).

14:9 frame

14:9 action area

4:3 image



Example 3 - 16:9 image format extracted from 4:3 source showing the residual horizontal 14:9 framing and action area. Original image width retained, height cropped to approx. 14:9 action limit. No black bars.

16:9 image

14:9 frame

14:9 action area



Example 4 - 16:9 image format extracted from 4:3 source showing the residual horizontal 14:9 framing and action area. Small black bars at the sides.

16:9 image

14:9 action area

14:9 frame

*Note 1* - The vertical resolution capability of the 16:9 display is not fully exploited in Example 3.

*Note 2* - If a 625-line system is used for 4:3 production and for extraction/display in 16:9, then the 4:3 and 16:9 displays have 576 active lines.

## Annex 2

### Safe areas for television programmes intended for wide-screen 625-line transmission

These guidelines are aimed at those involved in any stage of the programme-making process and at manufacturers of production equipment for programmes intended to be broadcast using 625-line transmission systems, particularly where simulcasting on 16:9 and 4:3 networks from a single programme master is involved.

Depending on the type of programme, priority for 16:9 productions may be given to protecting the content of the overall 16:9 wide-screen picture area or to protecting the 4:3 central zone. However, protection of the 14:9 central zone as a compromise option for programmes expected to be viewed on both 16:9 and 4:3 television displays has been found to work well in practice on most types of programme material.

In each case, within the chosen priority zone, two safe areas are needed. All essential action is placed inside an action safe area, and all graphics inside a graphics safe area.

For programmes made in the 16:9 wide-screen format protected for the compromise 14:9 central zone, these areas are specified in Appendix 1 to this Annex.

For programmes made in the 16:9 wide-screen format protected for the 4:3 central zone, these areas are specified in Appendix 2 to this Annex. This type of protection is useful where it is required to ensure that protection of a 16:9 picture is acceptable to international broadcasters who require a 4:3 version to have exactly the same protection as an original 4:3 production. This has been found to be particularly useful for some types of sport, and where certain types of international supply contracts exist.

Where there is no requirement to provide compatibility with a 4:3 display, the areas are specified in Appendix 3 to this Annex. Productions made in this way are currently in a minority, but their number could be expected to increase over a period of a number of years as the penetration of wide-screen television receivers grows, and as we move closer to the conclusion of the transition period to wide-screen broadcasting.

For programmes made in the 4:3 format protected for the 14:9 central zone, these areas are specified in Appendix 4 to this Annex.

All the safe areas have been specified on the premise that the overscan on modern domestic television receiver displays will normally be in the range  $3.5 \pm 1\%$  of overall picture width or height, but for any one picture edge, the overscan should not exceed 4% of total picture width or height. No account is taken of the possibility that viewers might choose to make use of the manual zoom functions available on many wide-screen receivers.

## Appendix 1 to Annex 2

### Safe areas for television programmes made in the 16:9 wide-screen format: Shoot-to-protect the compromise 14:9 central zone

Clearly the aspect ratios of 16:9 images and 4:3 displays are mutually incompatible. However, a number of broadcasters consider a 14:9 letter-box presentation provides a good compromise for many programme genres when a 16:9 wide-screen production is viewed on a 4:3 display. The wide-screen pictures must be framed to protect the 14:9 central zone.

The action safe area is within the 14:9 zone. However, for the time being, the graphics safe area should be constrained within the 4:3 central zone to ensure that graphics and captions are adequately protected when viewed under the least favourable conditions.

Table 1 shows how the action and graphics areas are defined to protect the 14:9 central zone in a 16:9 wide-screen image.

TABLE 1

	Vertical	Horizontal		
		16:9 image	14:9 zone	4:3 zone
Action safe margin (14:9) (%) <sup>1,2</sup>	3.5	10	4.2	–
Graphics safe margin (4:3) (%) <sup>3,4</sup>	5	15.9	11	4.5

Figure 1 shows these areas in more detail.

The definitions of the safe areas are given in numbers of lines and pixels, which are more definitive than the percentages used previously. However, percentages are also included because they are the basis on which comparisons are made. The line numbering has been calculated on the basis that field 1 is paired with the field 2 line below it, and the line from field 1 which is just inside the percentage box is defined as the edge of active picture.

Thus the drawings give the first and last lines and the first and last pixels which are inside the safe areas.

- 
- <sup>1</sup> The action safe margin is 3.5% at the top and bottom of the original 16:9 image. Since the height of the image does not change in 14:9 or 4:3 conversion, the vertical margin is the same in all three cases.
  - <sup>2</sup> The action safe margin is 10% at each side of the original 16:9 image. This is derived approximately from a 14:9 image reduced by 3.5% at each side. This is cropped to 4.2% at each side in 14:9 conversion as 1/16 of the image is lost at each side. Since the action safe area extends beyond the sides of the 4:3 converted image, there is no action safe margin for this image.
  - <sup>3</sup> The graphics safe margin is 5% at the top and bottom of the original 16:9 image. Since the height of the image does not change in 14:9 or 4:3 conversion, the vertical margin is the same in all three cases.
  - <sup>4</sup> The graphics safe margin is 15.9% at each side of the original 16:9 image. This is derived approximately from a 14:9 image reduced by 5% at each side. This is cropped to 11% at each side in 14:9 conversion as 1/16 of the image is lost at each side. It is further cropped to 4.5% at each side in 4:3 conversion as a further 1/16 of the image is lost at each side.

FIGURE 1

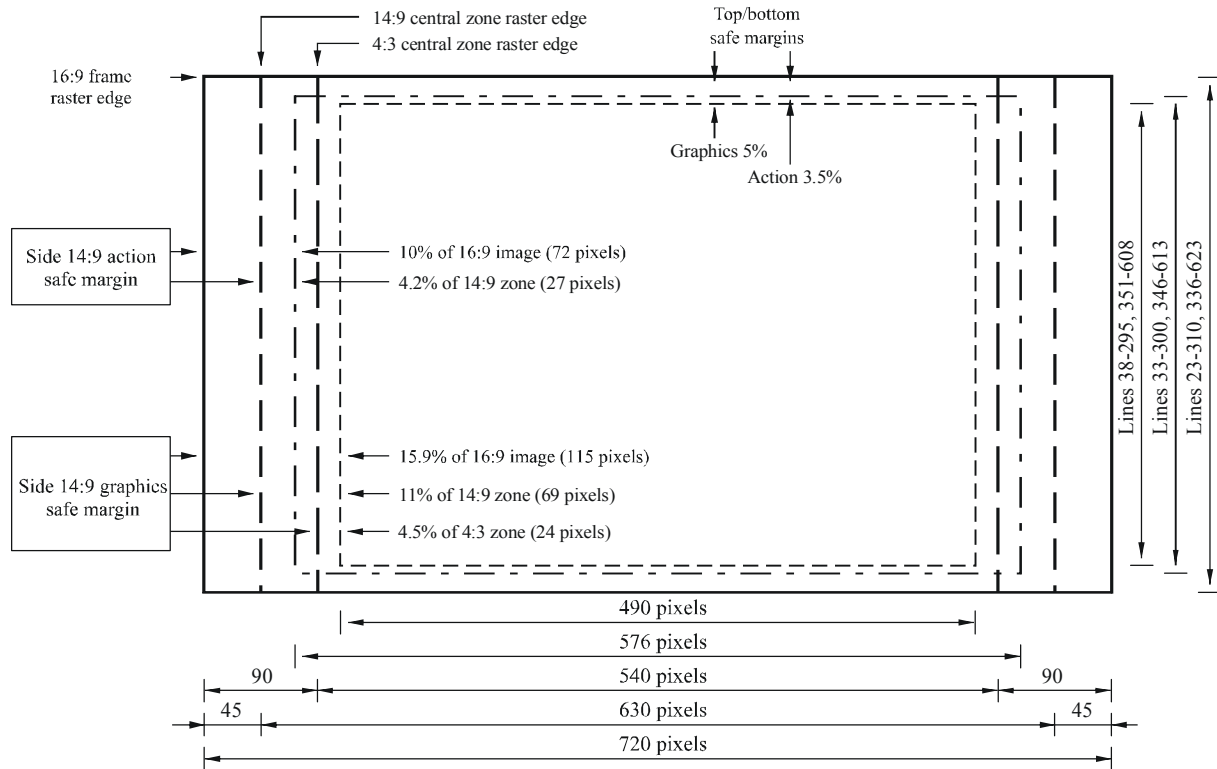
**16:9 shoot-to-protect 14:9 action and graphics safe areas**

1379-01

## Appendix 2 to Annex 2

### Safe areas for television programmes made in the 16:9 wide-screen format: Shoot-to-protect the 4:3 central zone

For certain programme genre there is a requirement to fully protect the 4:3 central zone for action and graphics. This may include sports productions, or where a fully compatible 4:3 image is required for international sales or on-passing to another broadcaster.

If the policy of the programme maker and/or the commissioner is to present 16:9 images on 4:3 services in the full screen mode, the 4:3 central zone should be protected. This will ensure that 16:9 pictures are 4:3 compatible. That is, the extracted 4:3 pictures will:

- frame the main subject of the 16:9 picture;
- comply with the normal artistic practice of framing in 4:3.

Table 2 shows how the action and graphics areas are defined to protect the 4:3 central zone in a 16:9 wide-screen image.



TABLE 2

	Vertical	Horizontal	
		16:9 image	4:3 zone
Action safe margin (%) <sup>5, 6</sup>	3.5	15	3.3
Graphics safe margin (%) <sup>7, 8</sup>	5	17.5	6.7

Figure 2 shows these areas in more detail.

FIGURE 2

16:9 shoot-to-protect 4:3 action and graphics safe areas

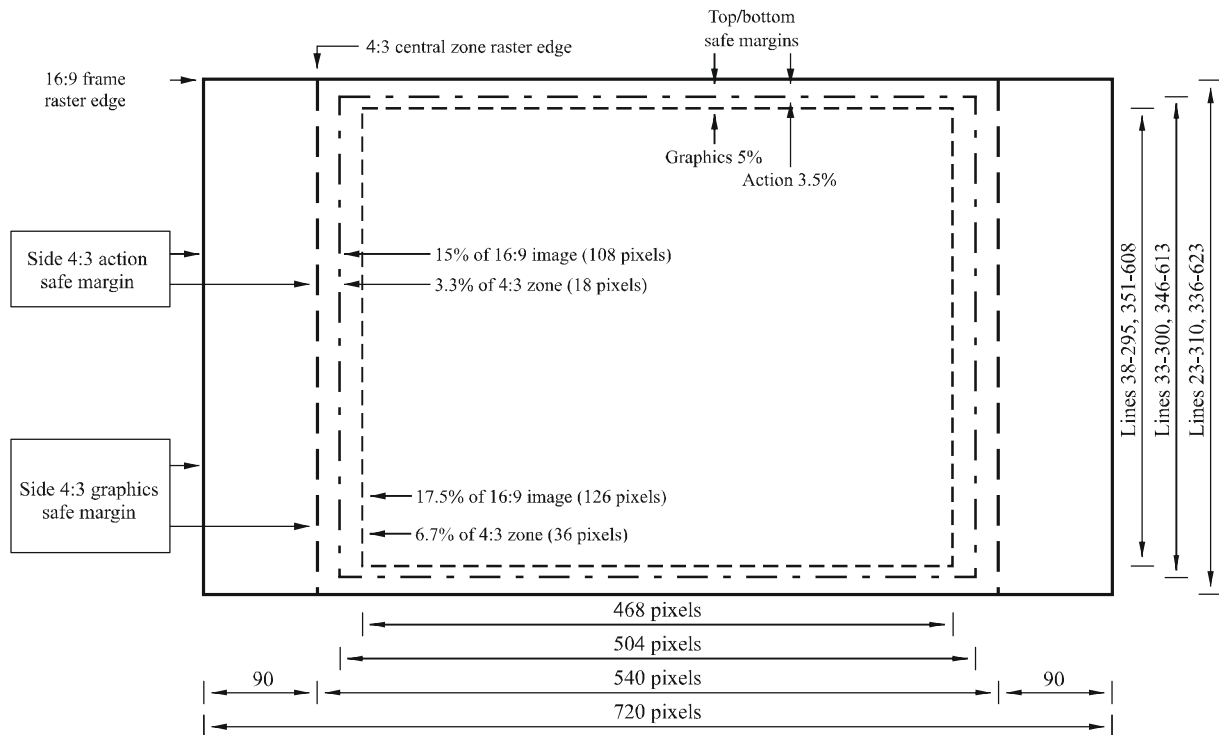

1379-02

The definitions of the safe areas are given in numbers of lines and pixels, which are more definitive than the percentages used previously. However, percentages are also included because they are the basis on which comparisons are made. The line numbering has been calculated on the basis that

- <sup>5</sup> The action safe margin is 3.5% at the top and bottom of the original 16:9 image. Since the height of the image does not change in 4:3 conversion, the vertical margin is the same in both cases.
- <sup>6</sup> The action safe margin is 15% at each side of the original 16:9 image. This is derived approximately from a 4:3 image reduced by 3.5% at each side. This is cropped to 3.3% at each side in 4:3 conversion as 1/8 of the image is lost at each side.
- <sup>7</sup> The graphics safe margin is 5% at the top and bottom of the original 16:9 image. Since the height of the image does not change in 4:3 conversion, the vertical margin is the same in both cases.
- <sup>8</sup> The graphics safe margin is 17.5% at each side of the original 16:9 image. This is derived approximately from a 4:3 image reduced by 5% at each side. This is cropped to 6.7% at each side in 4:3 conversion as 1/8 of the image is lost at each side.

field 1 is paired with the field 2 line below it, and the line from field 1 which is just inside the percentage box is defined as the edge of active picture.

Thus the drawings give the first and last lines and the first and last pixels which are inside the safe areas.

### Appendix 3 to Annex 2

#### Safe areas for television programmes made in the 16:9 wide-screen format: Shoot-to-protect the 16:9 full image

Table 3 shows how the action and graphics areas are defined to protect the full 16:9 wide-screen image. The horizontal graphics safe area is narrower to take account of the greater overscan on older receivers, which may affect wide-screen pictures when viewed in letter-box presentation.

TABLE 3

	Vertical	Horizontal
Action safe margin (%)	3.5	3.5
Graphics safe margin (%)	5	10

Figure 3 shows these areas in more detail.



The definitions of the safe areas are given in numbers of lines and pixels, which are more definitive than the percentages used previously. However, percentages are also included because they are the basis on which comparisons are made. The line numbering has been calculated on the basis that field 1 is paired with the field 2 line below it, and the line from field 1 which is just inside the percentage box is defined as the edge of active picture.

Thus the drawings give the first and last lines and the first and last pixels which are inside the safe areas.

## Appendix 4 to Annex 2

### Safe areas for television programmes made in the 4:3 format: Shoot-to-protect the 14:9 central zone

For certain programmes shot in 4:3 there is a requirement to protect the 14:9 central zone for action and graphics; for example, in cases where it is required that the 14:9 central zone be placed in a 16:9 frame for digital transmission.

Table 4 shows how the action and graphics areas are defined to protect the central 14:9 zone in a 4:3 image.

TABLE 4

	Vertical		Horizontal
	4:3 image	14:9 zone	
Action safe margin (%) <sup>9, 10</sup>	10	3.3	5
Graphics safe margin (%) <sup>11, 12</sup>	11.5	5	10

Figure 4 shows these areas in more detail.

The side safe areas are a compromise, but they allow protection of graphics when the 14:9 image is placed in a 16:9 wide-screen frame, and when such transmissions are viewed in the least favourable conditions by extraction of a 4:3 central zone cut-out. In such circumstances there is a minimal loss of safe action area. Figure 5 shows this situation in more detail.

---

<sup>9</sup> The action safe margin is 5% at the sides of the original 4:3 image. Since the sides remain unchanged in the 14:9 conversion, the action safe margin remains at 5% in the converted image.

<sup>10</sup> The action safe margin is 3.3% at the top and bottom of the 14:9 zone. Since 1/14 of the picture is cropped at the top and bottom, this becomes 10% of the original 4:3 picture.

<sup>11</sup> The graphics safe margin is 10% at the sides of the original 4:3 image. Since the sides remain unchanged in the 14:9 conversion, the action safe margin remains at 10% in the converted image.

<sup>12</sup> The graphics safe margin is 5% at the top and bottom of the 14:9 zone. Since 1/14 of the picture is cropped at the top and bottom, this becomes 11.5% of the original 4:3 picture.

The definitions of the safe areas are given in numbers of lines and pixels, which are more definitive than the percentages used previously. However, percentages are also included because they are the basis on which comparisons are made. The line numbering has been calculated on the basis that field 1 is paired with the field 2 line below it, and the line from field 1 which is just inside the percentage box is defined as the edge of active picture.

Thus the drawings give the first and last lines and the first and last pixels which are inside the safe areas.

FIGURE 4  
4:3 shoot-to-protect 14:9 action and graphics safe areas

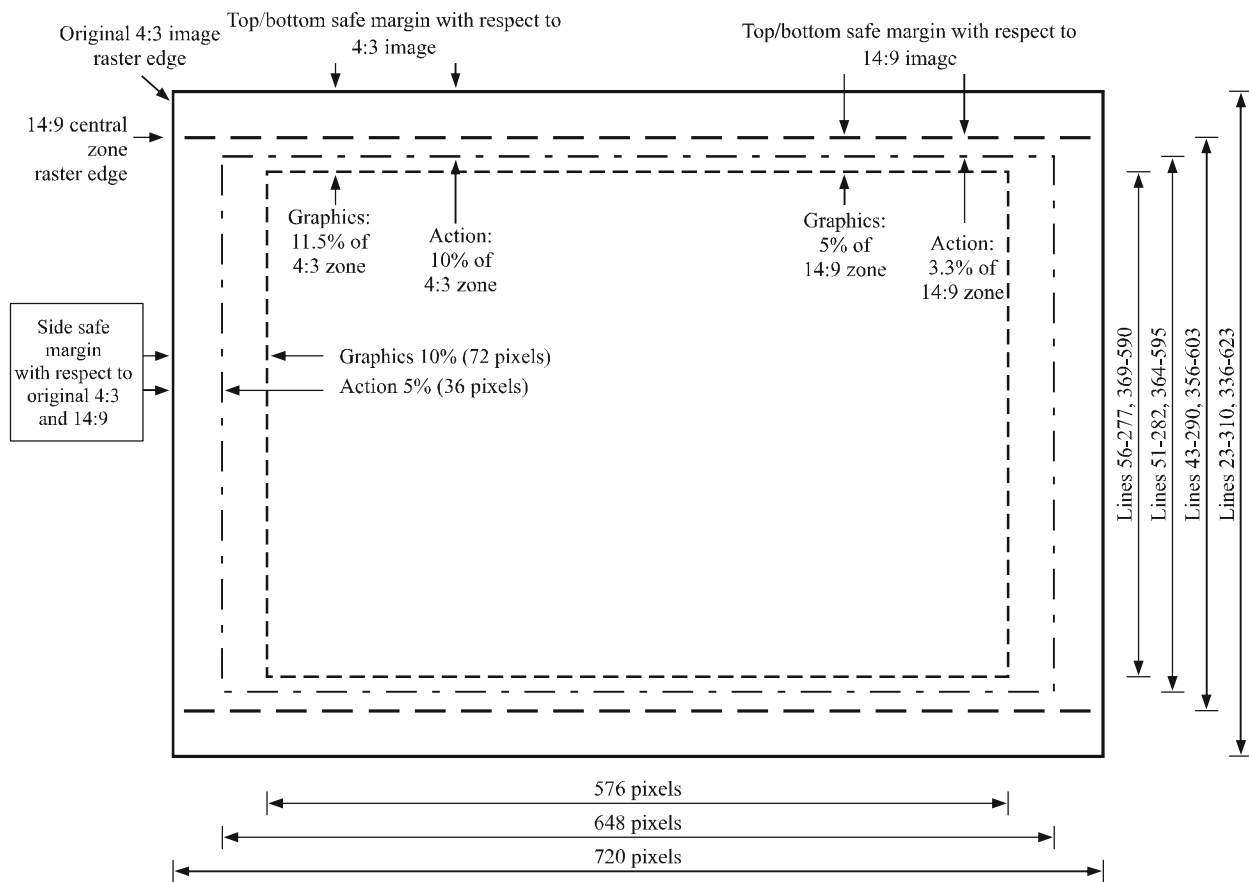
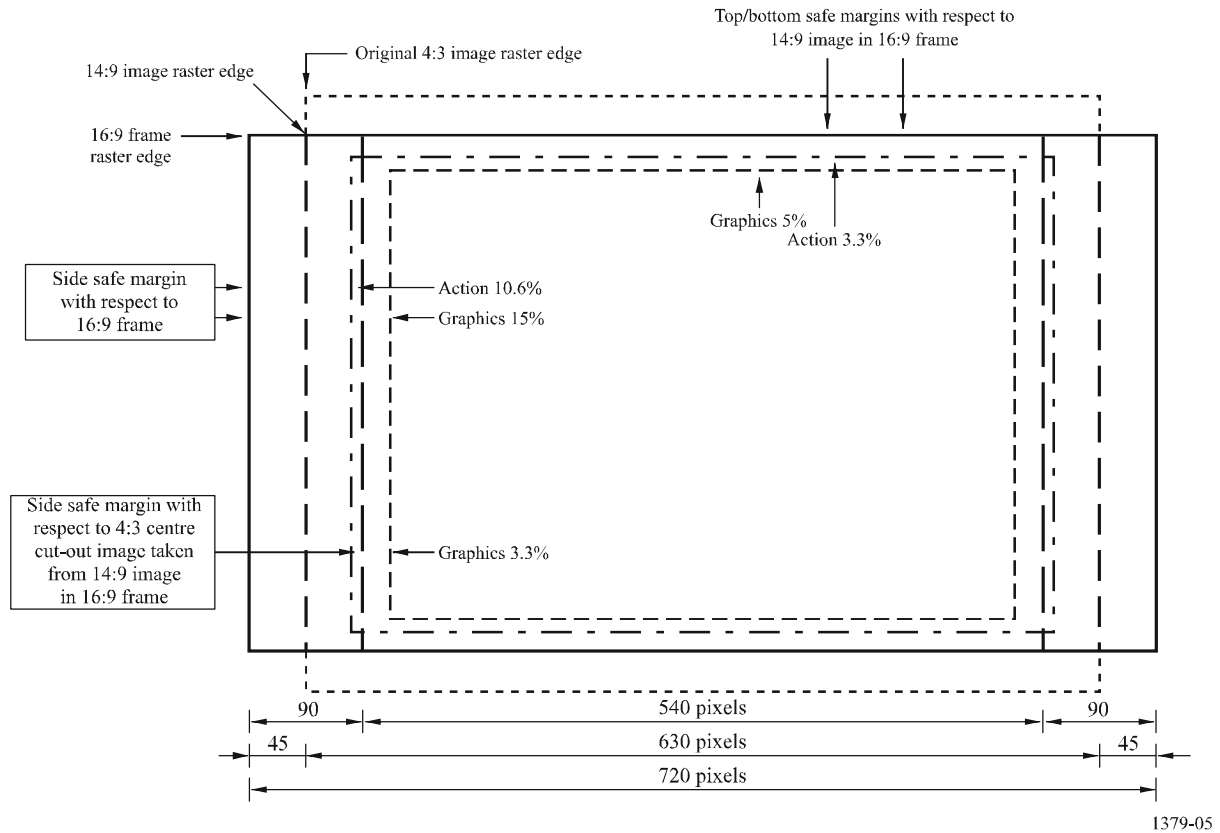

FIGURE 5  
**4:3 shoot-to-protect 14:9 action and graphics safe areas:  
 resulting 14:9 image when transmitted within 16:9 frame**



1379-05

### Annex 3

#### Safe areas for television programmes intended for wide-screen 1 080-line transmission

This Annex shows similar information to Annex 2 but with the lines and pixels numbered in accordance with 1 080-line format.

## Appendix 1 to Annex 3

### Safe areas for television programmes made in the 16:9 wide-screen format: Shoot-to-protect the compromise 14:9 central zone

Clearly the aspect ratios of 16:9 images and 4:3 displays are mutually incompatible. However, a number of broadcasters consider a 14:9 letter-box presentation provides a good compromise for many programme genres when a 16:9 wide-screen production is viewed on a 4:3 display. The wide-screen pictures must be framed to protect the 14:9 central zone.

The action safe area is within the 14:9 zone. However, for the time being, the graphics safe area should be constrained within the 4:3 central zone to ensure that graphics and captions are adequately protected when viewed under the least favourable conditions.

Table 5 shows how the action and graphics areas are defined to protect the 14:9 central zone in a 16:9 wide-screen image.

TABLE 5<sup>13</sup>

	Vertical	Horizontal		
		16:9 image	14:9 zone	4:3 zone
Action safe margin (14:9) (%)	3.5	10	4.2	–
Graphics safe margin (4:3) (%)	5	15	10	3.3

Figure 6 shows these areas in more detail.

The definitions of the safe areas are given in numbers of lines and pixels, which are more definitive than the percentages used previously. However, percentages are also included because they are the basis on which comparisons are made. The line numbering has been calculated on the basis that field 1 is paired with the field 2 line below it, and the line from field 1 which is just inside the percentage box is defined as the edge of active picture.

Thus the drawings give the first and last lines and the first and last pixels which are inside the safe areas.

---

<sup>13</sup> See notes to Table 1.

FIGURE 6  
16:9 shoot-to-protect 14:9 action and graphics safe areas, 1080 lines

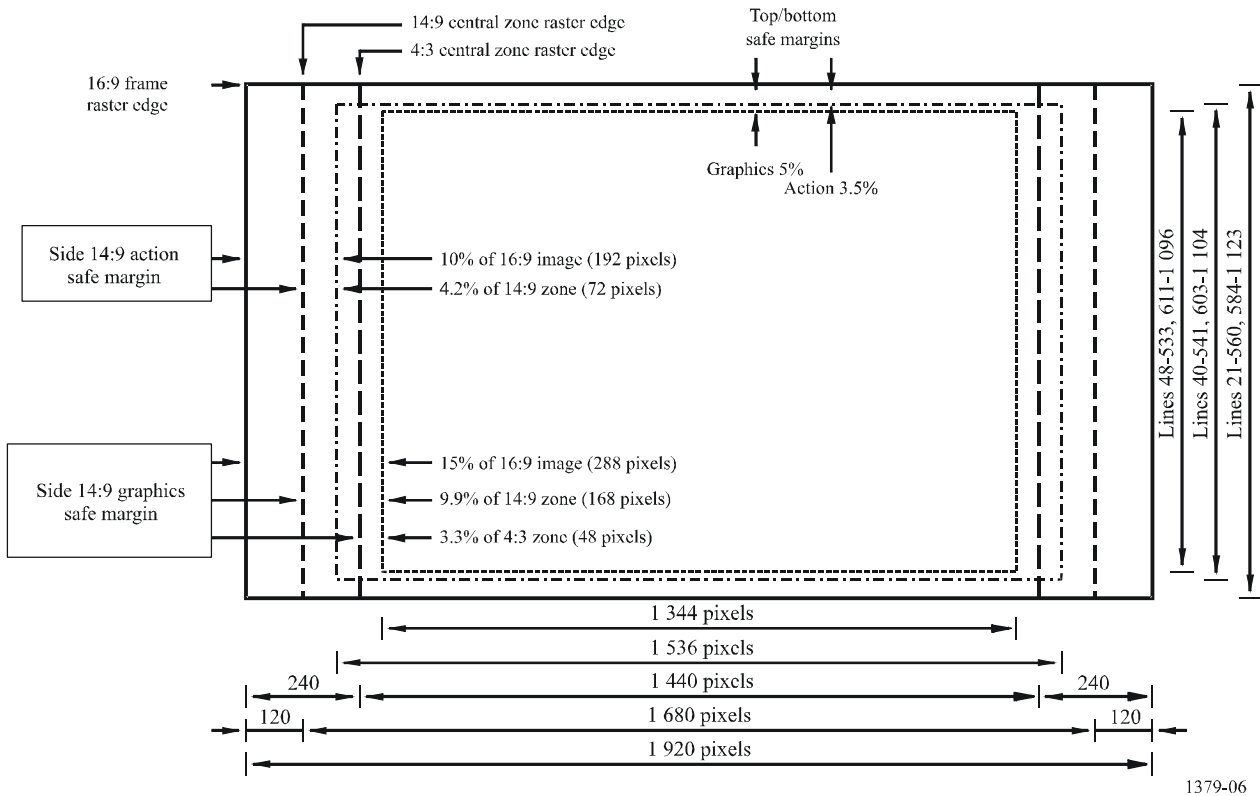

## Appendix 2 to Annex 3

### Safe areas for television programmes made in the 16:9 wide-screen format: Shoot-to-protect the 4:3 central zone

For certain programme genre there is a requirement to fully protect the 4:3 central zone for action and graphics. This may include sports productions, or where a fully compatible 4:3 image is required for international sales or on-passing to another broadcaster.

If the policy of the programme maker and/or the commissioner is to present 16:9 images on 4:3 services in the full screen mode, the 4:3 central zone should be protected. This will ensure that 16:9 pictures are 4:3 compatible. That is, the extracted 4:3 pictures will:

- frame the main subject of the 16:9 picture;
- comply with the normal artistic practice of framing in 4:3.

Table 6 shows how the action and graphics areas are defined to protect the 4:3 central zone in a 16:9 wide-screen image.

TABLE 6<sup>14</sup>

	Vertical	Horizontal	
		16:9 image	4:3 zone
Action safe margin (%)	3.5	15	3.3
Graphics safe margin (%)	5	17.5	6.7

Figure 7 shows these areas in more detail.

FIGURE 7  
16:9 shoot-to-protect 4:3 action and graphics safe areas, 1080 lines

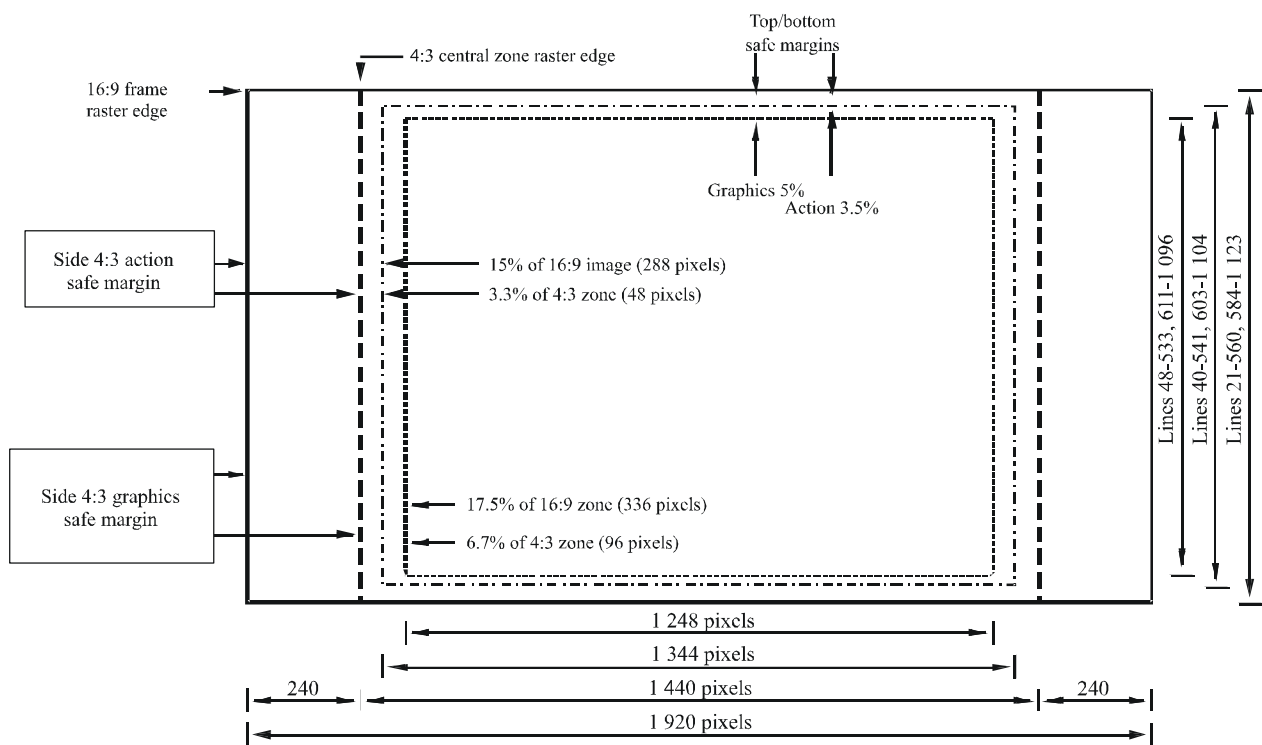

1379-07

The definitions of the safe areas are given in numbers of lines and pixels, which are more definitive than the percentages used previously. However, percentages are also included because they are the basis on which comparisons are made. The line numbering has been calculated on the basis that field 1 is paired with the field 2 line below it, and the line from field 1 which is just inside the percentage box is defined as the edge of active picture.

Thus the drawings give the first and last lines and the first and last pixels which are inside the safe areas.

<sup>14</sup> See notes to Table 2



## Annex 4

### Safe areas for television programmes intended for wide-screen 720-line transmission

This Annex shows similar information to Annex 2 but with the lines and pixels numbered in accordance with 720-line format.

### Appendix 1 to Annex 4

#### Safe areas for television programmes made in the 16:9 wide-screen format: Shoot-to-protect the compromise 14:9 central zone

Clearly the aspect ratios of 16:9 images and 4:3 displays are mutually incompatible. However, a number of broadcasters consider a 14:9 letter-box presentation provides a good compromise for many programme genres when a 16:9 wide-screen production is viewed on a 4:3 display. The wide-screen pictures must be framed to protect the 14:9 central zone.

The action safe area is within the 14:9 zone. However, for the time being, the graphics safe area should be constrained within the 4:3 central zone to ensure that graphics and captions are adequately protected when viewed under the least favourable conditions.

Table 7 shows how the action and graphics areas are defined to protect the 14:9 central zone in a 16:9 wide-screen image.

TABLE 7<sup>15</sup>

	Vertical	Horizontal		
		16:9 image	14:9 zone	4:3 zone
Action safe margin (14:9) (%)	3.5	10	4.2	–
Graphics safe margin (4:3) (%)	5	15	10	3.3

Figure 8 shows these areas in more detail.

The definitions of the safe areas are given in numbers of lines and pixels, which are more definitive than the percentages used previously. However, percentages are also included because they are the basis on which comparisons are made.

Thus the drawings give the first and last lines and the first and last pixels which are inside the safe areas.

---

<sup>15</sup> See notes to Table 1.

FIGURE 8  
16:9 shoot-to-protect 14:9 action and graphics safe areas, 720 lines

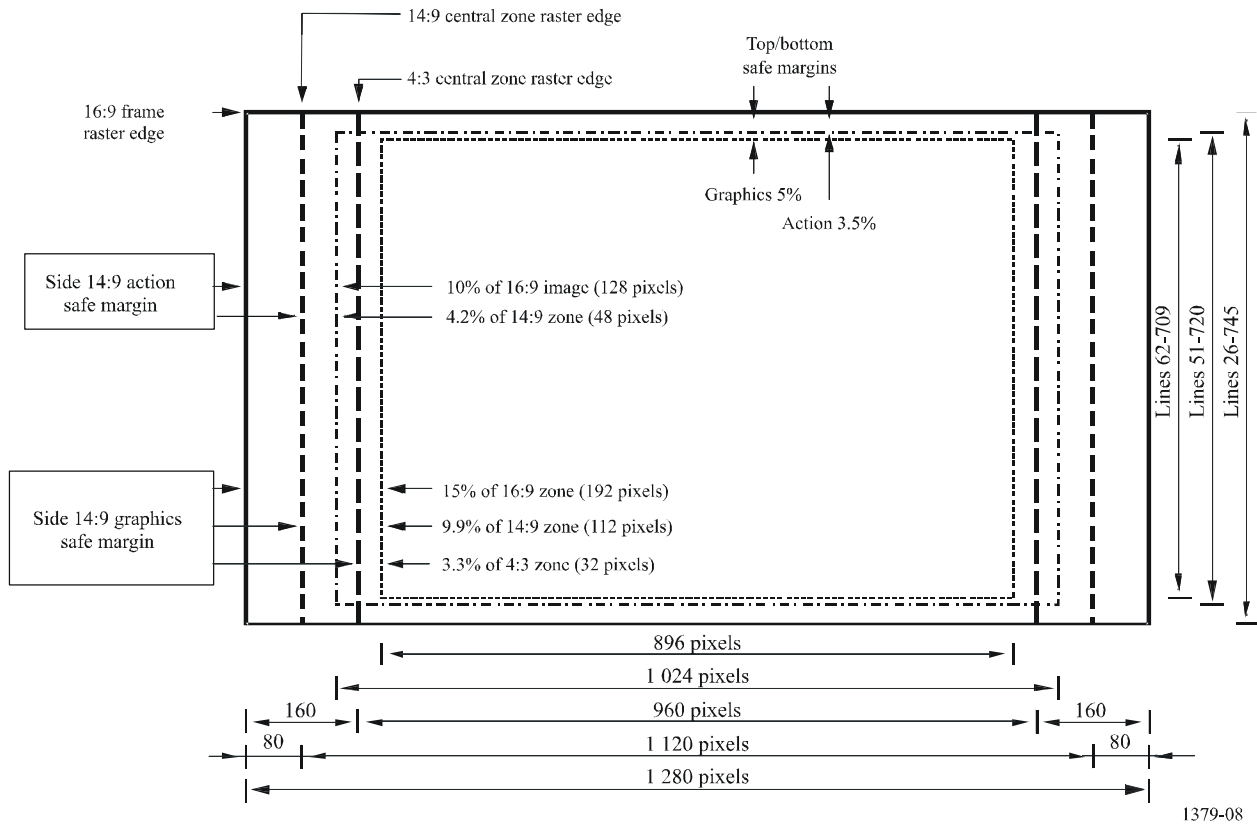

## Appendix 2 to Annex 4

### Safe areas for television programmes made in the 16:9 wide-screen format: Shoot-to-protect the 4:3 central zone

For certain programme genre there is a requirement to fully protect the 4:3 central zone for action and graphics. This may include sports productions, or where a fully compatible 4:3 image is required for international sales or on-passing to another broadcaster.

If the policy of the programme maker and/or the commissioner is to present 16:9 images on 4:3 services in the full screen mode, the 4:3 central zone should be protected. This will ensure that 16:9 pictures are 4:3 compatible. That is, the extracted 4:3 pictures will:

- frame the main subject of the 16:9 picture;
- comply with the normal artistic practice of framing in 4:3.

Table 8 shows how the action and graphics areas are defined to protect the 4:3 central zone in a 16:9 wide-screen image.

TABLE 8<sup>16</sup>

	Vertical	Horizontal	
		16:9 image	4:3 zone
Action safe margin (%)	3.5	15	3.3
Graphics safe margin (%)	5	17.5	6.7

Figure 9 shows these areas in more detail.

FIGURE 9  
16:9 shoot-to-protect 4:3 action and graphics safe areas, 720 lines

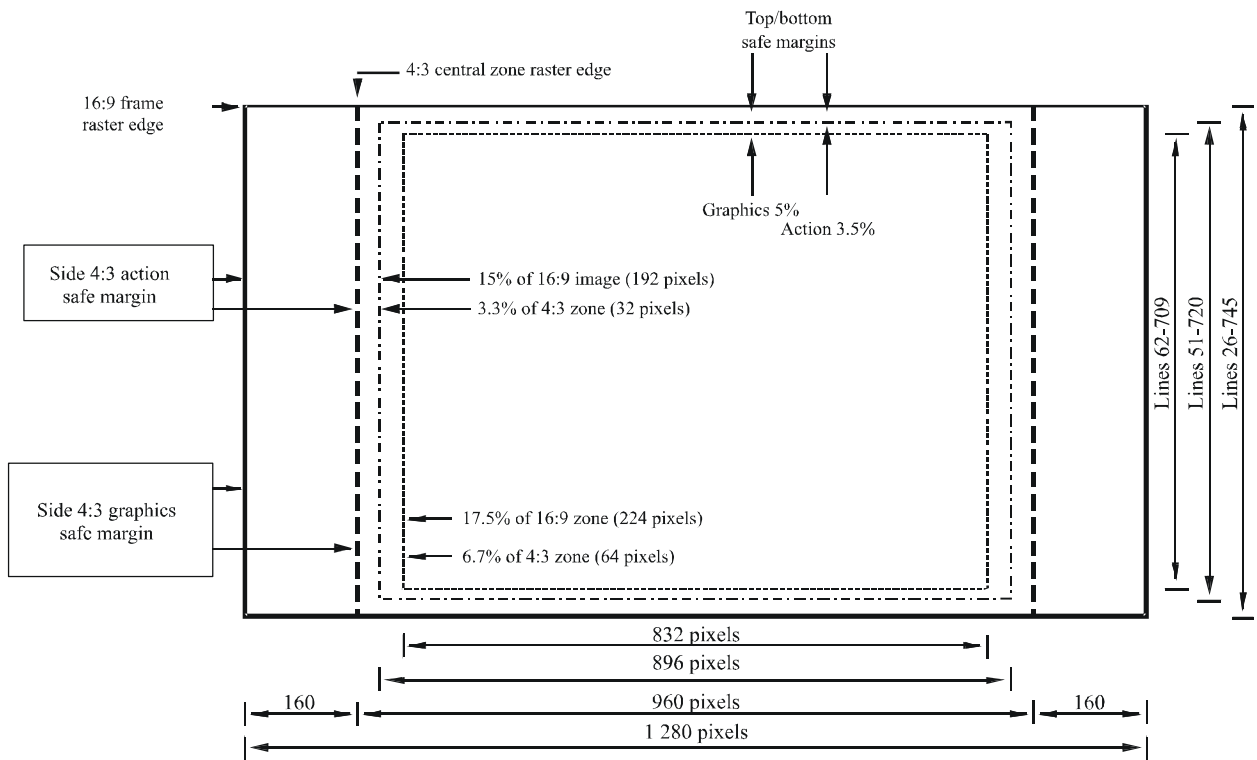

1379-08

The definitions of the safe areas are given in numbers of lines and pixels, which are more definitive than the percentages used previously. However, percentages are also included because they are the basis on which comparisons are made.

Thus the drawings give the first and last lines and the first and last pixels which are inside the safe areas.

<sup>16</sup> See notes to Table 2.