

International Telecommunication Union

ITU-R
Radiocommunication Sector of ITU

Recommendation ITU-R BT.1364-2
(03/2010)

**Format of ancillary data signals carried in
digital component studio interfaces**

BT Series
Broadcasting service
(television)



Foreword

The role of the Radiocommunication Sector is to ensure the rational, equitable, efficient and economical use of the radio-frequency spectrum by all radiocommunication services, including satellite services, and carry out studies without limit of frequency range on the basis of which Recommendations are adopted.

The regulatory and policy functions of the Radiocommunication Sector are performed by World and Regional Radiocommunication Conferences and Radiocommunication Assemblies supported by Study Groups.

Policy on Intellectual Property Right (IPR)

ITU-R policy on IPR is described in the Common Patent Policy for ITU-T/ITU-R/ISO/IEC referenced in Annex 1 of Resolution ITU-R 1. Forms to be used for the submission of patent statements and licensing declarations by patent holders are available from <http://www.itu.int/ITU-R/go/patents/en> where the Guidelines for Implementation of the Common Patent Policy for ITU-T/ITU-R/ISO/IEC and the ITU-R patent information database can also be found.

Series of ITU-R Recommendations

(Also available online at <http://www.itu.int/publ/R-REC/en>)

Series	Title
BO	Satellite delivery
BR	Recording for production, archival and play-out; film for television
BS	Broadcasting service (sound)
BT	Broadcasting service (television)
F	Fixed service
M	Mobile, radiodetermination, amateur and related satellite services
P	Radiowave propagation
RA	Radio astronomy
RS	Remote sensing systems
S	Fixed-satellite service
SA	Space applications and meteorology
SF	Frequency sharing and coordination between fixed-satellite and fixed service systems
SM	Spectrum management
SNG	Satellite news gathering
TF	Time signals and frequency standards emissions
V	Vocabulary and related subjects

Note: This ITU-R Recommendation was approved in English under the procedure detailed in Resolution ITU-R 1.

Electronic Publication
Geneva, 2010

© ITU 2010

All rights reserved. No part of this publication may be reproduced, by any means whatsoever, without written permission of ITU.

RECOMMENDATION ITU-R BT.1364-2

**Format of ancillary data signals carried
in digital component studio interfaces**

(Question ITU-R 130/6)

(1998-2005-2010)

Scope

This Recommendation defines the data structure for packetized data that may be carried as part of the payload in serial digital interfaces as defined in Recommendations ITU-R BT.656, ITU-R BT.799 and ITU-R BT.1120. Applications defining the content of the data packets are defined by other ITU Recommendations as listed in Appendix 4.

The ITU Radiocommunication Assembly,

considering

- a) that most digital television production facilities are based on the use of digital video components conforming to Recommendations ITU-R BT.601, ITU-R BT.656 and ITU-R BT.799;
- b) that most HDTV production systems are using digital interfaces based on interfaces conforming to Recommendation ITU-R BT.1120;
- c) that there exists the capacity within the serial digital interfaces conforming to Recommendations ITU-R BT.656, ITU-R BT.799 or ITU-R BT.1120 for additional data signals to be multiplexed along with the video data;
- d) that there are operational and economic benefits to be achieved by the multiplexing of ancillary data signals within the serial digital interface;
- e) that the operational benefits are increased if a minimum of different formats are used for ancillary data signals;
- f) that many applications are already using ancillary data signals carried in the serial digital interface,

recommends

- 1** that the ancillary data signal format described in Annex 1 should be used;
- 2** that compliance with this Recommendation is voluntary. However, the Recommendation may contain certain mandatory provisions (to ensure e.g. interoperability or applicability) and compliance with the Recommendation is achieved when all of these mandatory provisions are met. The words “shall” or some other obligatory language such as “must” and the negative equivalents are used to express requirements. The use of such words shall in no way be construed to imply partial or total compliance with this Recommendation.

Annex 1

Ancillary data signal format

1 General description of the ancillary data signal format

The format specified provides a mechanism for the transport of ancillary data signals through digital video component interfaces in the digital blanking portion of the digital video data signal. The ancillary data is carried in packets, each packet carrying its own identification. A packet comprises:

- a fixed preamble to enable an ancillary data packet to be detected;
- data identification to enable packets carrying a particular type of ancillary signal to be identified;
- a packet length indication;
- a continuity indication;
- the ancillary data, up to 255 words in each packet;
- a checksum to permit error detection.

Provision is made for ancillary data exceeding 255 words to be carried in two or more linked packets, not necessarily contiguous with each other.

A protocol is described which permits a number of different ancillary data packets to be carried within the space available in the digital blanking intervals of the digital component interface signal and allows for the insertion and deletion of ancillary data packets. The ancillary data packets may either be in horizontal ancillary data space, or vertical ancillary data space.

During a horizontal interval of every television line, the ancillary data space that is located between EAV and SAV markers is called horizontal ancillary data space (HANC space).

During a vertical interval of each frame, the ancillary data space located between SAV and EAV markers is called vertical ancillary data space (VANC space).

NOTE 1 – Attention is drawn to the existence of other ancillary data signals, such as digitized time code and checksum, for error detection and status information, which occupy specific locations in the digital line- and field-blanking areas. These locations should not be used for the insertion of further ancillary data signals. Attention is drawn to the fact that signal switching disturbances will affect certain parts on the field and line-blanking areas and these locations should also not be used for the insertion of ancillary data signals (see Appendix 3).

NOTE 2 – The integrity of a data path for ancillary signals through all equipment cannot be assumed.

NOTE 3 – To avoid confusion between 8-bit and 10-bit representations of word values, the eight most-significant bits are considered to be an integer part while the two additional bits, if present, are considered to be fractional parts.

For example, the bit pattern 10010001 would be expressed as 145_d or 91_h , whereas the pattern 1001000101 would be expressed as 145.25_d or 91.4_h .

Where no fractional part is shown, it can be assumed to have the binary value 00.

2 8-bit considerations

The parallel and serial digital video component interfaces described in Recommendation ITU-R BT.656 are capable of passing 10-bit data words. Some legacy interfaces may only pass 8 bits.

The passage of a 10-bit signal through such an 8-bit equipment results in truncation and the loss of the two LSBs, while serializing an 8-bit signal for transmission through the 10-bit serial interface results in two additional bits – usually zeros – being appended to the signal data bits.

By taking the above considerations into account, provision is made for a limited number of applications in which ancillary data will not be corrupted by either truncation or setting the two LSBs to zero (see Appendix 1).

For digital HDTV interfaces conforming to Recommendation ITU-R BT.1120, only 10-bit operation is suggested.

3 Ancillary data packet format

3.1 Ancillary data packet types

Ancillary data packets are divided into Type 1 and Type 2, where Type 1 uses a single word for data identification and Type 2 uses two words for this purpose: this allows a wide range of identification values to be used.

A total of 189 data identification values are reserved for 8-bit applications, as described in § 3.4, whereas approximately 29 000 values are provided for 10-bit applications.

The two types are shown in Fig. 1.

The two types of data identification in the ancillary data packet format are specified below:

- *Type 1*: Uses a single word data identification, defined as data ID (DID), which is followed by data block number (DBN) and data count (DC).
- *Type 2*: Uses a two word data identification, defined as a combination of data ID (DID) and a secondary data ID (SDID) which is followed by a data count (DC).

Ancillary data is defined as 10-bit words. This is required by the structure of the signal format and its interface.

FIGURE 1
Ancillary data packet types

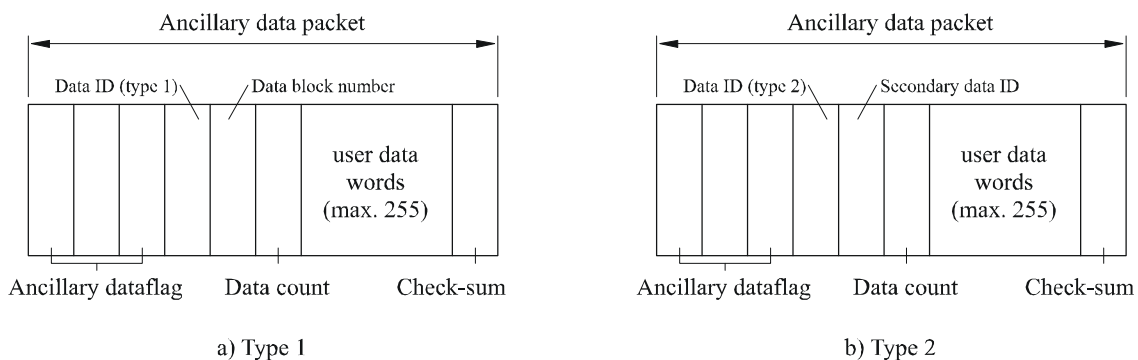

1364-01

3.1.1 Type 1 ancillary data packets

Ancillary data packets of Type 1 are composed of:

- an ancillary data flag (ADF) which marks the beginning of the ancillary data packet;

- a data ID (DID) which defines the nature of the data carried in the user data words of the ancillary data packet;
- a data block number (DBN) word for Type 1 only, which distinguishes successive ancillary data packets with a common data ID;
- a data count (DC) number which defines the quantity of user data words in the ancillary data packet;
- the user data words (UDW), maximum of 255 words in each ancillary data packet: the user data format is defined in a specific application text;
- a checksum (CS) word.

3.1.2 Type 2 ancillary data packets

Ancillary data packets of Type 2 are composed of the same elements as Type 1 ancillary data packets except for the DBN, which is replaced by a secondary data identification word (SDID).

3.2 Ancillary data flag

The ancillary data flag (ADF) consists of a three-word sequence having the values: 00.0_h FF.C_h FF.C_h.

NOTE 1 – To maximize compatibility between 8-bit and 10-bit equipment, it is recommended that data values of 00.0_h-00.C_h and FF.0_h-FF.C_h be processed identically. References in this Recommendation to specific data values in either of those two ranges should apply to all data values within the same range (see Appendix 1).

3.3 Data identification word

The data identification word (DID) consists of 10 bits, of which 8-bits carry the identification value, as shown in Table 1, and the remaining bits carry even parity and its inverse as shown:

- bits b7 (MSB)-b0 (LSB) form the identification value (00_h-FF_h);
- bit b8 is even parity for b7-b0;
- bit b9 = not b8.

DID words are divided into Type 1 and Type 2 categories. In general, the setting of bit b7=1 indicates Type 1 and b7=0 indicates Type 2 data identification. The exception to this categorization is word 00_h which identifies an undefined format (see § 3.4.1).

3.3.1 Reserved data identification words

DID words shown in Table 1 as “internationally registered” are for ancillary data packets of interest to most organizations and are registered with the standards-setting organizations listed in Appendix 2.

DID words shown as “user application” are not registered and are restricted to values in the range shown. They may be assigned by the user and/or by the manufacturer of the specified equipment.

DID words shown as “reserved for 8-bit applications” are restricted to three values in the range shown. Out of the values 04_h-0F_h reserved for 8-bit applications, the only valid values are 04_h, 08_h, and 0C_h. Other values in the reserved range would be truncated to these three values DID words shown as “reserved” are reserved for future use.

TABLE 1
Identification value assignment

a) DID		
Data type	Data value	Data assignment
Type 2 (2-word ID)	00 _h	Undefined format
	01 _h 02 _h 03 _h	Reserved ¹⁾
	04 _h : 0F _h	Reserved for 8-bit applications ²⁾
	10 _h : 3F _h	Reserved
	40 _h : 4F _h	Internationally registered
	50 _h : 5F _h	User application
	60 _h : 7F _h	Internationally registered
Type 1 (1-word ID)	80 _h	Marked for deletion
	81 _h 82 _h 83 _h	Reserved ¹⁾
	84 _h	End marker
	85 _h 86 _h 87 _h	Reserved ¹⁾
	88 _h	Start marker
	89 _h 8A _h 8B _h	Reserved ¹⁾
	8C _h : 9F _h	Reserved
	A0 _h : BF _h	Internationally registered
	C0 _h : CF _h	User application
	D0 _h : FF _h	Internationally registered

3.4 Secondary data identification word (Type 2 data only)

The secondary data identification (SDID) word consists of 10 bits, comprising an 8-bit identification value plus parity and its inverse as shown:

- bits b7 (MSB)-b0 (LSB) form the identification 8-bit value ($00_{\text{h}}\text{-FF}_{\text{h}}$);
- bit b8 is even parity for b7-b0;
- bit b9 = not b8.

For 10-bit applications, SDID words which are part of the Type 2 data identification format may be in the range from $01_{\text{h}}\text{-FF}_{\text{h}}$ as shown in Table 1. Value 00_{h} is reserved for an undefined format.

In 8-bit applications, only six bits are available in the SDID, giving 64 possible values, as indicated below:

$$x0_{\text{h}}, x4_{\text{h}}, x8_{\text{h}}, xC_{\text{h}}$$

where x may be any value in the range $0_{\text{h}}\text{-F}_{\text{h}}$.

Setting aside the value 00_{h} for the undefined format (see Table 1), the remaining 63 values, combined with the 3 values available in the DID, give a maximum of 189 different identification values.

3.4.1 Data identification for an undefined format

The identification value of 00_{h} for an undefined format is provided for compatibility with some existing equipment and must not be used in new applications.

3.5 Data block number (Type 1 data only)

The data block number (DBN) is incremented by 1 for each consecutive, related Type 1 data packet sharing a common DID and requiring continuity indication.

The DBN value in the Type 1 data identification system is carried in 8 bits and is incremented from 1 to 255 where:

- bits b7 (MSB)-b0 (LSB), carry the data block (packet) number value;
- bit b8 is even parity for b7-b0;
- bit b9 = not b8.

NOTE 1 – If more than 255 packets are required for a particular ancillary data signal, then the DBN is cycled continuously from 1 to 255 with subsequent groups of packets.

When bits b7-b0 of the DBN are set to zero, the DBN is inactive and is not used by the receiver to indicate data continuity.

3.6 Data count

The data count (DC) word represents the number of UDWs to follow, in the range 0-255 words. In 10-bit applications it comprises:

- bits b7 (MSB)-b0 (LSB), carry the data count value;
- bit b8 is even parity for b7-b0;
- bit b9 = not b8.

When an ancillary data packet is intended to be used in, or is generated by, an 8-bit application, bits b0 and b1 are either not present (8-bit interface) or are set to zero. Consequently, the DC consists of the following:

- bit b7 (MSB)-b2 (LSB) are the 6 MSBs of the data count;
- bit b8 is the even parity bit for b7-b2;
- bit 9 = not b8.

NOTE 1 – As a result of two LSBs being set to zero, the number of user data words (UDWs) in the packet can be resolved only in increments of four data words. As a result, the number of UDWs in the packet must be an integral number of four words, with padding employed if necessary to meet this requirement.

3.7 User data words

UDW are used to convey information as identified by the DID and must not include the protected codes: 00.0_h, 00.4_h, 00.8_h, 00.C_h, and FF.C_h, FF.8_h, FF.4_h, FF.0_h (00_h and FF_h in 8-bit applications).

The method to be used for avoiding the occurrence of protected codes in the UDWs is not part of this Recommendation but should be specified for each application.

In 8-bit applications, the UDW values are carried in bits b9-b2.

The maximum number of UDWs in a single packet is 255.

3.8 Checksum word

The checksum word (CS) word is used to determine the validity of the ancillary data packet from the DID through the UDWs. It consists of 10 bits, a 9-bit value and bit b9, as defined below:

- bits b8 (MSB)-b0 (LSB) are the checksum value;
- bit b9 = not b8.

In 10-bit applications the CS value is equal to the nine least significant bits of the sum of the nine least significant bits of the DID, the DNB or the SDID, the DC and all UDWs in the packet.

In 8-bit applications, where the two LSBs of every 10-bit word in the packet are set to zeros, the CS word is calculated in the same way as for 10-bit applications. (The LSBs produce a zero sum themselves and produce no carry bit.)

Prior to the start of the CS count cycle all CS and carry bits are pre-set to zero. Any carry resulting from the CS count cycle is ignored.

The CS word provides a limited capability for error detection and none for error correction. Where required, an appropriate error detection/correction algorithm should be employed on the user data.

4 Protocol for the use of ancillary data space

One or more ancillary data packets may be inserted in any area defined as available for ancillary data, i.e. the digital line blanking intervals (HANC) and field blanking intervals (VANC) except those areas already assigned to other uses (see § 1, Note 1).

In interfaces conforming to Recommendation ITU-R BT.1120, the data words corresponding to the luminance and colour-difference channels are considered to form two independent ancillary data spaces, each of which begins with its own timing reference signal (and line number and CRCC).

Ancillary data packets must follow immediately after the EAV or SAV timing reference signals (including the line number and CRCC words in interfaces conforming to Recommendation ITU-R BT.1120) indicating the start of an ancillary data space. Consequently, if the first three

words in that space is not an ADF (00.0_h 00.0_h FF.C_h), it can be assumed that no ancillary data packets are present and that the entire area is available for the insertion of data packets. Timing reference signals must not be overwritten.

When an interface conforming to Recommendation ITU-R BT.1120 is used for the transport of embedded audio in the line-blanking area of the colour-difference channel, this area should not be used for any other purpose.

Within an available area, ancillary data packets must be contiguous with each other.

Ancillary data packets must be wholly contained within the ancillary space in which they are inserted: they must not be split between ancillary data spaces.

Apart from these requirements, the particular protocol employed for the insertion and deletion of ancillary data signals is at the discretion of individual users. A possible form of protocol is given in Appendix 3.

NOTE 1 – Checksums for error detection and status information, as specified in Recommendation ITU-R BT.1304 are located in fixed positions within the ancillary data space and therefore are not overwritten or appended to other ancillary data packets or subject to the contiguity requirements of this specification.

Appendix 1 to Annex 1

Eight- and ten-bit considerations

1 Introduction

The parallel and serial digital video component interfaces described in Recommendation ITU-R BT.656 are capable of passing 10-bit data words. Some legacy equipment may only pass 8 bits.

The passage of a 10-bit signal through such an 8-bit equipment results in truncation and the loss of the two LSBs. Whilst this can be tolerated for digital video data, it has the effect of destroying the ancillary data signal unless precautions are taken. The subsequent serializing of the truncated 8-bit signal for transmission through the 10-bit serial interface results in two additional bits – usually zeros – being appended to the signal data bits (see Fig. 2).

FIGURE 2

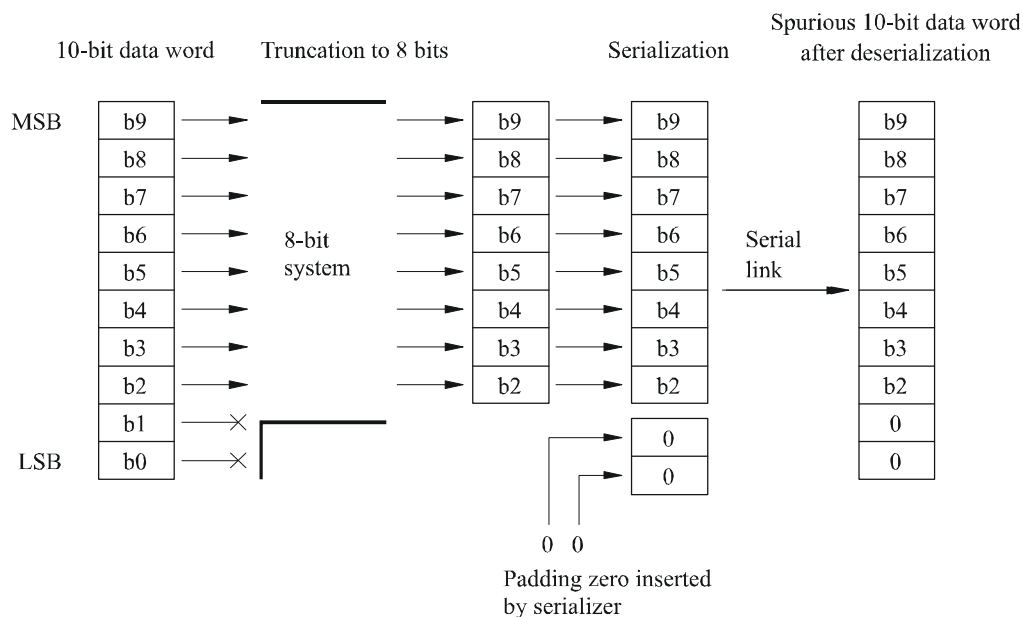
Corruption of a data word

1364-02

Similarly, data words originated in 8-bit form become extended to 10-bit form as a result of passage through a serial interface according to Recommendation ITU-R BT.656.

Whilst the two additional bits are usually both zeros, this cannot be guaranteed always. Consequently, for detection of the timing reference signals (TRS) and ancillary data flags (ADF), data values in the ranges $00.0_h-00.C_h$ and $FF.0_h-FF.C_h$ should be processed identically as 00.0_h and $FF.C_h$ respectively.

2 Eight-bit compatibility

It is possible to design an ancillary data signal that is usable in both 8-bit and 10-bit systems, provided recognition is given to the effects of passage through eight- and ten-bit systems.

2.1 Data identification

Ancillary data signals designed for 8-bit applications are Type 2 signals and contain both DID and SDID data-words.

DID words shown in Table 1 as “reserved for 8-bit applications” are restricted to three values in the range shown. Out of the values 04_h-0F_h reserved for 8-bit applications, the only valid values are 04_h , 08_h , and $0C_h$. Other values in the reserved range would be truncated to these three values.

The two most-significant bits of the data-words used for SDID carry an even parity bit and its inverse. Consequently, in 8-bit applications, only six bits are available in the SDID data-words as shown in Fig. 3. This results in 64 possible values, as indicated below:

$$x0_h, x4_h, x8_h, xC_h$$

where x may be any value in the range 0_h-F_h .

Setting aside the value 00_h for the undefined format, the remaining 63 values in the SDID, combined with the 3 assigned values available in the DID for eight-bit applications, give a maximum of 189 different identification values.

FIGURE 3
Coding range for 8-bit DID, SDID, DC

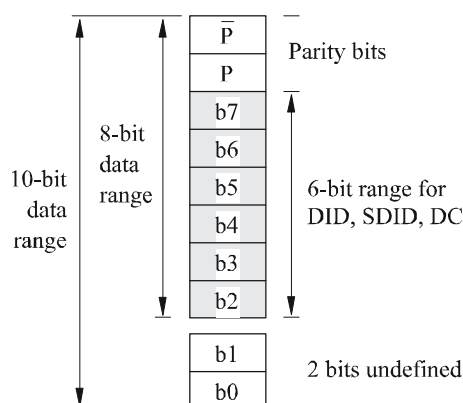

1364-03

2.2 Data count

When an ancillary data packet is intended to be used in, or is generated by, an 8-bit application, bits b0 and b1 are either not present (8-bit interface) or are set to zero. Consequently, the DC consists of the following:

- bit b7 (MSB)-b2 (LSB) are the 6 MSBs of the data count;
- bit b8 is the even parity bit for b7-b2;
- bit 9 = not b8.

Only six bits are available in the DC to specify the number of user data words in an eight-bit ancillary data signal. Consequently, if the maximum number of user data words in a packet is not to be reduced from 256 words to 64 then the DC can be specified only in blocks of four words. For example a DC of 14 would indicate 56 data-words and a DC of 15 would indicate 60 data-words.

The number of user data words in an ancillary data packet for eight-bit applications is justified to an integer number of 4-word blocks by insertion of padding words if necessary.

2.3 User data words

It is a requirement that the protected values 00_h and FF_h do not appear in the user data words. The method used to achieve this is not part of this Recommendation but should be specified for each application. As examples, one method is the use of two bits in each word as for DID, SDID, DBN and DC. A second method is the use of seven data bits plus a single odd parity bit, while a third would be to restrict the coding range to exclude the protected values as is done for video data.

2.4 Checksum

In 10-bit applications the checksum value is equal to the nine least significant bits of the sum of the nine least significant bits of the DID, the DBN or the SDID, the DC and all UDWs in the packet.

In 8-bit applications, where the two LSBs of every 10-bit word in the packet are set to zeros, the CS word is calculated in the same way as for 10-bit applications. The LSBs produce a zero sum themselves and hence produce no carry bit to affect the checksum.

Appendix 2 to Annex 1

Internationally registered ancillary data identification

The following organization is a registration authority for ancillary data identifications referred to as “internationally registered” in § 3.3.1 of this Recommendation. The registration authority coordinates the assignment of DID and SDID numbers.

Registration authority:

Society of Motion Picture and
Television Engineers (SMPTE)
3 Barker Avenue
5th Floor
White Plains
NY 10601
United States of America

Users of this Recommendation should check the following URL for the latest registered values of DID/SDID assignments < www.smp-te-ra.org >.

Appendix 3 to Annex 1

A protocol for the use of ancillary data space

1 General

One or more ancillary data packets may be inserted in any area defined as available for ancillary data, i.e. the digital line and field blanking intervals except those areas already assigned to other uses.

Ancillary data packets must follow immediately after the EAV or SAV timing reference signals indicating the start of the available area. If the first three-word sequence of an available area is not an ancillary data flag it can be assumed that no ancillary data packets are present and that the entire area is available for the insertion of data packets. Timing reference signals must not be overwritten.

Within an available area, ancillary data packets must be contiguous with each other.

NOTE 1 – It is recommended that ancillary data packets are not transmitted within the ancillary spaces listed in Table 2, as switching disturbances are likely to corrupt any ancillary data present.

TABLE 2
Ancillary data space affected by switching

Sampling frequency	Line standard	Ancillary space affected
13.5	525	10/273 words 0-1 439 11/274 words 1 444-1 711
13.5	625	6/319 words 0-1 439 7/320 words 1 444-1 723
74.25 (74.25/1.001)	1125	7/569 words 0-1 919 8/570 words 1 928-2 195 and 0-1 919

2 Inclusion of non-conforming ancillary data packets

The use of ancillary data packets not conforming to the format described in this Recommendation, such as those requiring unbroken user data word sequences longer than 255 words, is not recommended.

If their use cannot be avoided, provision is made for their inclusion as non-standard packets in a sequence of ancillary data packets, but they may be corrupted by equipment that does not incorporate these provisions.

The insertion of a non-conforming ancillary data packet must be preceded by the insertion of a start marker packet and followed by either an end marker packet or a conforming ancillary data packet. Start markers and end markers are conforming packets and have a length of 7 words, including the ADF: they are identified as follows:

- start marker packet DID = 88_h;
- end marker packet DID = 84_h.

The use of start and end marker packets is illustrated in Fig. 4.

The DC and the DBN for these packets shall be set to zero (0). The length of these packets shall be constant and equal to four words excluding the ADF.

NOTE 1 – After passing through an 8-bit interface, serializing the signal will result in the two LSBs being undefined in the 10-bit domain. Consequently, DIDs in the range 88_h-8B_h must all be interpreted as identifying start marker packets and those in the range 84_h-87_h must be interpreted as identifying end marker packets.

3 Protocol for the insertion of an ancillary data packet

3.1 Determination of space available for insertion of ancillary data packet

Ancillary data space begins with an EAV or SAV code depending on whether it is contained within the line blanking or field blanking periods.

FIGURE 4
Insertion of non-conforming ancillary data packet

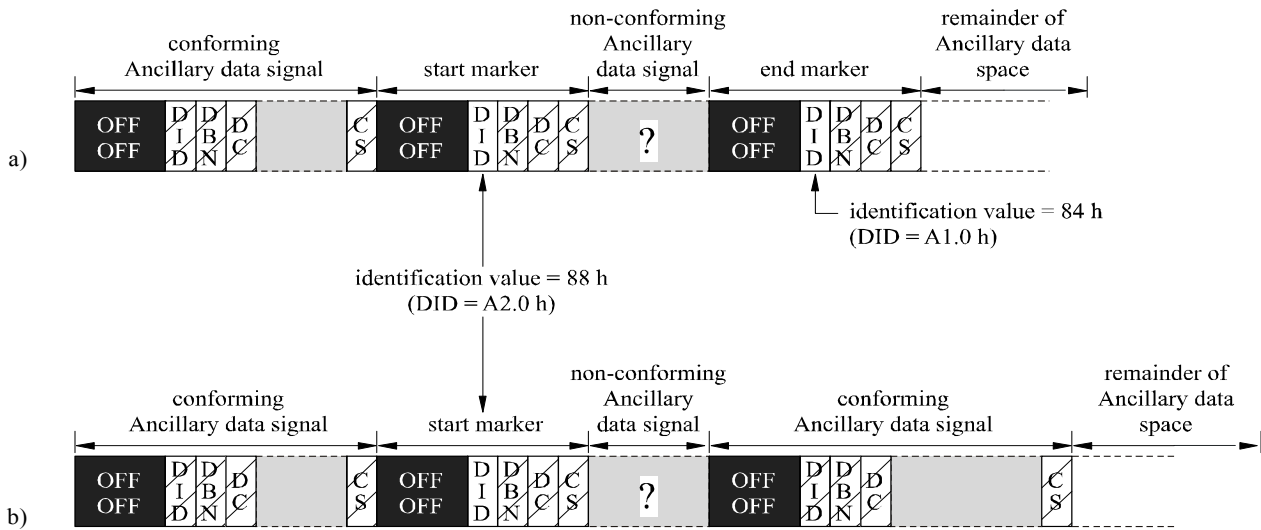

a) end denoted by end Marker

b) end denoted by conforming ancillary data signal.

1364-04

Starting at the beginning of a particular ancillary data space, the data words are tested for the presence of any of the following:

- A conforming ADF – if not, the entire remaining space is available and insertion must begin immediately after the EAV or SAV code.
- If an ancillary data signal is present, the identification value is tested to determine whether that ANC data signal is an end marker or a deletion marker or a start marker.
- If a start marker is detected, each subsequent data word is tested until an ADF is detected or the end of the ancillary data space is reached.
- If an end marker is detected, the space occupied by the end marker plus the remaining space in that ancillary data space is available.
- If a packet marked for deletion is detected, it may be replaced by a new ancillary data signal, subject to the procedures in § 3.2 d) being followed.
- If a standard ancillary data signal is detected, the DC of that signal is used to locate the end of the data packet, whereupon the remaining space is tested as above.

3.2 Insertion of an ancillary data packet

- a) Sufficient space must be available for the entire packet to be inserted within the same ancillary data space.
- b) An end marker is replaced by a new inserted ancillary data packet or by a start marker in the case of the insertion of a non-standard ancillary data packet.
- c) If a non-standard ancillary data packet is to be inserted, it must be followed immediately by an end marker.

- d) If a packet is marked for deletion, and a new ancillary data packet replaces part of the space occupied by the to-be-deleted packet, an additional ancillary data packet must be created occupying the residual space in order to preserve the contiguity of ancillary data packets (see § 4).

4 Protocol for the deletion of an ancillary data packet

Deletion of an ancillary data packet is achieved by replacing the DID of the ancillary data packet with a data identification value of 80_h and inserting a recalculated checksum for the packet. This serves to mark the packet as deleted whilst retaining contiguity of data packets within the ancillary space.

It is possible to insert a new ancillary data packet in the space occupied by a packet marked for deletion. However, it is necessary to maintain contiguity of packets by the insertion of a further packet to fill the space remaining after insertion. This further packet will have a data identification value of 80_h and a length equal to the space remaining after insertion of the new packet. A new checksum value must be calculated. Since the minimum size of an ancillary data packet is 7 words, it is necessary to verify that this amount of space will remain in the space made available.

This procedure is illustrated in Fig. 5.

NOTE 1 – After passing through an 8-bit interface, serializing the signal will result in the two LSBs being undefined in the 10-bit domain. Consequently, DIDs in the range 80_h-83_h must all be interpreted as identifying packets for deletion.

FIGURE 5
Deletion of an ancillary packet and re-use of ancillary data space

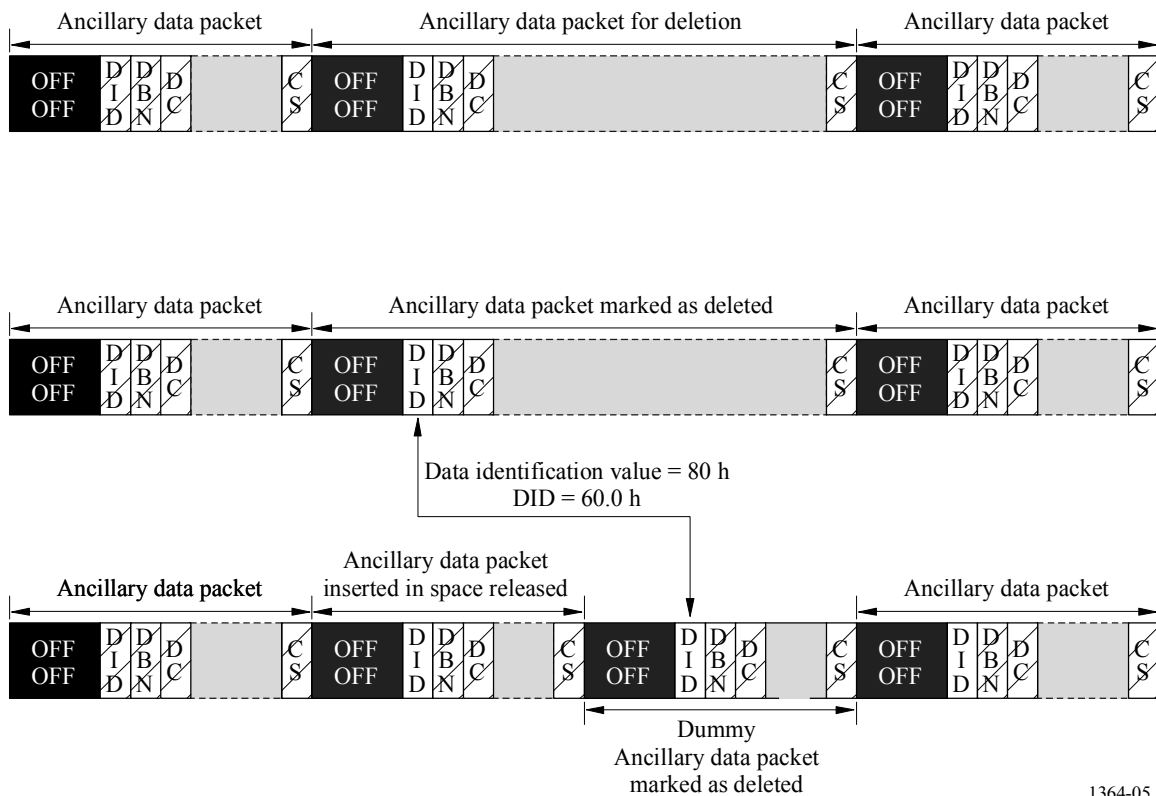

Appendix 4 to Annex 1

Assigned ancillary ID codes for ancillary packets with payload formats defined in ITU-R Recommendations

Tables 3 and 4 provide a list of assigned ancillary identification codes for applications utilizing ancillary data as defined by this Recommendation. Each payload format is defined in the relevant ITU-R Recommendation.

TABLE 3

Assigned ancillary ID codes Type 1 data

DID	Application	Recommendation ITU-R
00 _h	Undefined data	BT.1364
80 _h	Packet marked for deletion	
84 _h	End packet	
88 _h	Start packet	
E0 _h	Audio control packet (HDTV), group 4	BT.1365
E1 _h	Audio control packet (HDTV), group 3	
E2 _h	Audio control packet (HDTV), group 2	
E3 _h	Audio control packet (HDTV), group 1	
E4 _h	Audio data packet (HDTV), group 4	
E5 _h	Audio data packet (HDTV), group 3	
E6 _h	Audio data packet (HDTV), group 2	
E7 _h	Audio data packet (HDTV), group 1	BT.1305
EC _h	Audio control packet (SDTV), group 4	
ED _h	Audio control packet (SDTV), group 3	
EE _h	Audio control packet (SDTV), group 2	
EF _h	Audio control packet (SDTV), group 1	BT.1304
F4 _h	Error detection data packet	BT.1305
F8 _h	Audio extended data packet (SDTV), group 4	
F9 _h	Audio data packet (SDTV), group 4	
FA _h	Audio extended data packet (SDTV), group 3	
FB _h	Audio data packet (SDTV), group 3	
FC _h	Audio extended data packet (SDTV), group 2	
FD _h	Audio data packet (SDTV), group 2	
FE _h	Audio extended data packet (SDTV), group 1	
FF _h	Audio data packet (SDTV), group 1	

TABLE 4
Assigned ancillary ID codes Type 2 data

DID	SDID	Application	Recommendation ITU-R
00 _h	00 _h	Undefined data	BT.1364
40 _h	01 _h	SDTI	BT.1381
40 _h	02 _h	HD-SDTI	BT.1577
41 _h	01 _h	Video payload identifier	BT.1614
43 _h	01 _h	Inter-station control data packet	BT.1685
60 _h	60 _h	Ancillary time code packet	BT.1366
61 _h	01 _h	Closed captioning (EIA-708-D)	BT.1619
61 _h	02 _h	EIA- 608-E data	
62 _h	01 _h	DTV programme description	
62 _h	02 _h	DTV data broadcast	
62 _h	03 _h	VBI data	
80 _h	00 _h	Packet marked for deletion	BT.1364
84 _h	00 _h	End packet	
88 _h	00 _h	Start packet	

Appendix 5 to Annex 1

Assigned ancillary ID codes for ancillary packets with payload formats defined as part of the DID/SDID registration process

Tables 5 and 6 reflect registered DID/SDID values as of November 2009. Readers are encouraged to check later registered values at <www.smpte-ra.org>.

TABLE 5
Assigned ancillary ID codes type 1 data

DID	Application	Source
F0	Camera position data (HANC or VANC space)	SMPTE 315M

TABLE 6
Assigned ancillary ID codes Type 2 data

DID	SDID	Application	Source
00 _h	00 _h	Undefined data	BT.1364
88 _h	00 _h	Start packet	
80 _h	00 _h	Packet marked for deletion	
84	00	End packet	
08 _h	08 _h	Video recoding data packet (V-ANC)	SMPTE 353
08 _h	0C _h	Video recoding data packet (H-ANC)	
40 _h	01 _h	SDTI	BT.1381
40 _h	02 _h	HD-SDTI	BT.1577
40 _h	04 _h	Link Encryption Message 1	SMPTE 427
40 _h	05 _h	Link Encryption Message 2	
40 _h	06 _h	Link Encryption Metadata	
41 _h	01 _h	Video payload identifier	BT.1614
41 _h	05 _h	AFD and Bar Data	SMPTE 2016-3
41 _h	06 _h	Pan and Scan data	SMPTE S2016-4
41 _h	07 _h	ANSI/SCTE 104 messages	SMPTE RP2010
41 _h	08 _h	DVB/SCTE VBI data	SMPTE S2031
43 _h	01 _h	Inter-station control data packet	BT.1685
43 _h	02 _h	Subtitling distribution package (SDP) http://www.freetv.com.au/media/Engineering/OP_47_Issues_4_-_Storage_and_Distribution_of_Teletext_Subtitle_and_VBI_Data_for_High_Definition_Television_December_2008.pdf	OP47 Free TV Australia
43 _h	03 _h	Transport of multi-packet ANC data http://www.freetv.com.au/media/Engineering/OP_47_Issues_4_-_Storage_and_Distribution_of_Teletext_Subtitle_and_VBI_Data_for_High_Definition_Television_December_2008.pdf	OP47 Free TV Australia
43 _h	04 _h	http://www.arib.or.jp/english/html/overview/doc/8-TR-B29v1_0-E1.pdf	ARIB-TR-B29
44 _h	04 _h	K LV Metadata transport in VANC space	SMPTE RP214
44 _h	14 _h	K LV Metadata transport in HANC space	
44 _h	44 _h	Packing UMID and Program Identification Label Data into Ancillary Data Packets	SMPTE RP 223
45 _h	01 _h	Compressed Audio Metadata Data	SMPTE 2020-1
45 _h	02 _h	Compressed Audio Metadata Data	
45 _h	03 _h	Compressed Audio Metadata Data	
45 _h	04 _h	Compressed Audio Metadata Data	
45 _h	05 _h	Compressed Audio Metadata Data	
45 _h	06 _h	Compressed Audio Metadata Data	
45 _h	07 _h	Compressed Audio Metadata Data	
45 _h	08 _h	Compressed Audio Metadata Data	
45 _h	09 _h	Compressed Audio and Metadata Data	
50 _h	01 _h	WSS data per RDD 8	
51 _h	01 _h	Film Codes in VANC space	SMPTE RP215
51 _h	02 _h	Acquisition Metadata Sets for Video Camera Parameters	SMPTE RDD 18
60 _h	60 _h	Ancillary Time Code	BT.1366
61 _h	01 _h	EIA 708D Data mapping into VANC space	SMPTE 334

TABLE 6 (*end*)

DID	SDID	Application	Source
61 _h	02 _h	EIA 608 Data mapping into VANC space	SMPTE 334
62 _h	01 _h	Program Description in VANC space	SMPTE RP207
62 _h	02 _h	Data broadcast (DTV) in VANC space	SMPTE 334-1
62 _h	03 _h	VBI Data in VANC space	SMPTE RP208
64 _h	64 _h	Use is not now encouraged	
64 _h	7F _h	Use is not now encouraged	
