



**Recommendation ITU-R BS.1114-11**  
(06/2019)

**Systems for terrestrial digital sound  
broadcasting to vehicular, portable  
and fixed receivers in the frequency  
range 30-3 000 MHz**

**BS Series**  
**Broadcasting service (sound)**

## Foreword

The role of the Radiocommunication Sector is to ensure the rational, equitable, efficient and economical use of the radio-frequency spectrum by all radiocommunication services, including satellite services, and carry out studies without limit of frequency range on the basis of which Recommendations are adopted.

The regulatory and policy functions of the Radiocommunication Sector are performed by World and Regional Radiocommunication Conferences and Radiocommunication Assemblies supported by Study Groups.

## Policy on Intellectual Property Right (IPR)

ITU-R policy on IPR is described in the Common Patent Policy for ITU-T/ITU-R/ISO/IEC referenced in Resolution ITU-R 1. Forms to be used for the submission of patent statements and licensing declarations by patent holders are available from <http://www.itu.int/ITU-R/go/patents/en> where the Guidelines for Implementation of the Common Patent Policy for ITU-T/ITU-R/ISO/IEC and the ITU-R patent information database can also be found.

### Series of ITU-R Recommendations

(Also available online at <http://www.itu.int/publ/R-REC/en>)

Series	Title
<b>BO</b>	Satellite delivery
<b>BR</b>	Recording for production, archival and play-out; film for television
<b>BS</b>	<b>Broadcasting service (sound)</b>
<b>BT</b>	Broadcasting service (television)
<b>F</b>	Fixed service
<b>M</b>	Mobile, radiodetermination, amateur and related satellite services
<b>P</b>	Radiowave propagation
<b>RA</b>	Radio astronomy
<b>RS</b>	Remote sensing systems
<b>S</b>	Fixed-satellite service
<b>SA</b>	Space applications and meteorology
<b>SF</b>	Frequency sharing and coordination between fixed-satellite and fixed service systems
<b>SM</b>	Spectrum management
<b>SNG</b>	Satellite news gathering
<b>TF</b>	Time signals and frequency standards emissions
<b>V</b>	Vocabulary and related subjects

*Note: This ITU-R Recommendation was approved in English under the procedure detailed in Resolution ITU-R 1.*

Electronic Publication  
Geneva, 2019

© ITU 2019

All rights reserved. No part of this publication may be reproduced, by any means whatsoever, without written permission of ITU.

## RECOMMENDATION ITU-R BS.1114-11

**Systems for terrestrial digital sound broadcasting to vehicular, portable and fixed receivers in the frequency range 30-3 000 MHz**

(Question ITU-R 56/6)

(1994-1995-2001-2002-2003-2004-2007-2011-2014-2015-2017-2019)

**Scope**

This Recommendation describes several systems for terrestrial digital sound broadcasting to vehicular, portable and fixed receivers in the frequency range 30-3 000 MHz. The main features of each system, such as source coding, channel coding, modulation, transmission structure and threshold levels to achieve good quality of service, are described.

**Keywords**

Digital Sound Broadcasting, DAB, ISDB-TSB, IBOC, DRM, CDR, RAVIS

The ITU Radiocommunication Assembly,

*considering*

- a)* that there is an increasing interest worldwide for terrestrial digital sound broadcasting (DSB) to vehicular, portable and fixed receivers in the frequency range 30-3 000 MHz for local, regional and national coverage;
- b)* that the ITU-R has already adopted Recommendations ITU-R BS.774 and ITU-R BO.789 to indicate the necessary requirements for DSB systems to vehicular, portable and fixed receivers for terrestrial and satellite delivery, respectively;
- c)* that Recommendations ITU-R BS.774 and ITU-R BO.789 recognize the benefits of complementary use of terrestrial and satellite systems, and call for a DSB system allowing for a common receiver with common processing very large scale integration (VLSI) circuits and manufacturing of low-cost receivers through mass production;
- d)* that Digital System A described in Annex 2 meets all the requirements of Recommendations ITU-R BS.774 and ITU-R BO.789, and that the system has been field-tested and demonstrated in various frequency bands between 200 MHz and 1 500 MHz in a number of countries;
- e)* that Digital System F described in Annex 3 meets the requirements of Recommendation ITU-R BS.774, and that the system has been field-tested and demonstrated in the 188-192 MHz and 2 535-2 655 MHz bands in more than one country;
- f)* that Digital System C described in Annex 4 meets the requirements of Recommendation ITU-R BS.774, and that the system has been field-tested and demonstrated in the 88-108 MHz band;
- g)* that Digital System G described in Annex 5 meets the requirements of Recommendation ITU-R BS.774, and that the system with Mode E has been successfully field-tested and demonstrated in VHF Band I (47-68 MHz), in VHF Band II (87.5-108 MHz) and in VHF Band III (174-230 MHz);
- h)* that Digital System H described in Annex 6 meets the requirements of Recommendation ITU-R BS.774, and that the system has been field-tested and demonstrated in the 88-108 MHz band;
- i)* that Digital System I described in Annex 7 meets the requirements of Recommendation ITU-R BS.774, and that the system has been field-tested and demonstrated in the 66-74 MHz and 87.5-108 MHz bands;

j) that at the 7<sup>th</sup> World Conference of Broadcasting Unions (México, 27-30 April 1992), the World Broadcasting Unions unanimously resolved:

“1 that efforts should be made to agree on a unique worldwide standard for DAB and  
2 to urge administrations to give consideration to the benefits for the consumer of common source and channel coding and implementation of Digital Sound Broadcasting on a worldwide basis at 1.5 GHz;”

k) that the MPEG-2 transport stream (MPEG-2 TS) is widely applied as containers of digitally coded information;

l) that a standardization process in Europe has resulted in the adoption of Digital System A (Eureka 147 as an ETSI Standard EN 300 401) for BSS (sound) broadcasting sound to vehicular, portable and fixed receivers;

m) that a standardization process in Japan has resulted in the adoption of Digital System F for integrated services digital broadcasting-terrestrial for sound broadcasting (ISDB-T<sub>SB</sub>) for digital terrestrial sound broadcasting system to vehicular, portable and fixed receivers;

n) that ISDB techniques can be used to implement services exploiting the full advantages of digital broadcasting, and that Recommendation ITU-R BT.1306 includes the ISDB-T system for digital terrestrial television broadcasting;

o) that a standardization process in the United States of America has resulted in the adoption of Digital System C (the IBOC system) as NRSC-5 for digital terrestrial sound broadcasting to vehicular, portable and fixed receivers;

p) that a standardization process in Europe has resulted in the adoption of Digital System G (DRM as an ETSI Standard ES 201 980) for digital terrestrial sound broadcasting system to vehicular, portable and fixed receivers;

q) that a standardization process in the People's Republic of China has resulted in the adoption of Digital System H (the CDR system) standard (GY/T 268.1-2013) for digital terrestrial sound broadcasting to vehicular, portable and fixed receivers;

r) that a standardization process in Russian Federation has resulted in the adoption of National standard (GOST R 54309-2011) for Digital System I (the RAVIS system) for digital terrestrial sound and multimedia broadcasting to vehicular, portable and fixed receivers,

*noting*

a) that a summary of digital systems is presented in Annex 1;

b) that the condensed system descriptions for Digital Systems A, C, F, G, H and I are given in Annexes 2, 3, 4, 5, 6 and 7, respectively;

c) that complete system descriptions of Digital Systems A, F and C are contained in the Digital Sound Broadcasting Handbook,

*recommends*

1 that Digital Systems A, F, C, G, H and/or I, as described in Annexes 2, 3, 4, 5, 6 and 7, respectively, should be used for terrestrial DSB services to vehicular, portable and fixed receivers in the frequency range 30-3 000 MHz as appropriate;

2 that administrations that wish to implement terrestrial DSB services meeting some or all of the requirements as stated in Recommendation ITU-R BS.774, should use Table 1 to evaluate the respective merits of Digital Systems A, F, C, G, H and I in selecting systems,

*invites the ITU membership and radio-receiver manufacturers to consider*

- 1** economically viable, portable, multiband, multistandard radio receivers designed to work, through manual or preferably automatic selection, with all the different analogue and digital radio broadcasting systems currently in use in all the relevant frequency bands;
- 2** digital radio receivers allowing downloading of upgrades for some of their specific functionalities, such as decoding, navigation, management capability etc.;
- 3** a simple indicator of the received RF field level and of the bit error rate.

TABLE 1

**Performance of Digital Systems A, F, C, G, H and I evaluated on the basis of the recommended technical and operating characteristics listed in Recommendation ITU-R BS.774**

<b>Characteristics from Rec. ITU-R BS.774 (condensed wording)</b>	<b>Digital System A</b>	<b>Digital System F</b>	<b>Digital System C</b>	<b>Digital System G</b>	<b>Digital System H</b>	<b>Digital System I</b>
Range of audio quality and types of reception	<p>Range is from 8 to 384 kbit/s per audio channel in increments of 8 kbit/s with up to 64 services per ensemble (but typically between 10 and 20). MPEG-2 Layer II or MPEG-4 HE-AACv2 audio decoder typically operating in the range 32 to 192 kbit/s is implemented in receivers.</p> <p>The system is intended for vehicular, portable and fixed reception.</p>	<p>Range is from phone quality to CD quality. It is also capable of 5.1 multi-channel audio. MPEG-2 advanced audio coding (AAC) decoder typically operates at 144 kbit/s for stereo.</p> <p>The system is intended for vehicular, portable and fixed reception.</p>	<p>Range is from 12 kbit/s to 96 kbit/s using the HD Codec<sup>(1)</sup> decoder, including support of various formats of multichannel audio.</p> <p>The system is intended for vehicular<sup>(2)</sup>, portable and fixed reception.</p>	<p>Range of the useful content bit rate is from 37-186 kbit/s for the whole multiplex ensemble with a maximum of four services in all modes.</p> <p>Using the MPEG-4 HE-AAC v2 audio decoder CD quality is achieved. It is also capable of 5.1 multichannel audio.</p> <p>The system is intended for vehicular, portable and fixed reception<sup>(3)</sup>.</p>	<p>Range is from 16 (compatible with FM quality) to 320 kbit/s (CD quality and future 5.1 multi-channel audio).</p> <p>Using the DRA+ (GD/J 058-2014) audio decoder, CD quality is achieved at 96 kbit/s.</p> <p>The system is intended for vehicular, portable and fixed reception.</p>	<p>Range of the useful bit rate is from 52 to 800 kbit/s for the whole multiplex.</p> <p>Using the MPEG-4 HE-AAC v2 audio decoder CD quality is achieved. It is also capable of multichannel and immersive audio.</p> <p>The system is intended for vehicular, portable and fixed reception.</p>



TABLE 1 (continued)

<b>Characteristics from Rec. ITU-R BS.774 (condensed wording)</b>	<b>Digital System A</b>	<b>Digital System F</b>	<b>Digital System C</b>	<b>Digital System G</b>	<b>Digital System H</b>	<b>Digital System I</b>
<p>Spectrum efficiency better than FM</p>	<p>FM stereo quality achievable in less than 200 kHz bandwidth; co-channel and adjacent channel protection requirements much less than those for FM. Efficiency is especially high in the case of repeaters reusing the same frequency. (Orthogonal multi-carrier modulation with convolution error correcting coding, coded orthogonal frequency division multiplex (COFDM)).</p>	<p>FM stereo quality achievable in less than 200 kHz bandwidth; co-channel and adjacent channel protection requirements much less than those for FM. Efficiency is especially high in the case of repeaters reusing the same frequency. It can be more effective by using 16/64-quadrature amplitude modulation (QAM) carrier modulation. (Orthogonal frequency division multiplex (OFDM) with concatenated block and convolutional error correcting coding).</p>	<p>FM stereo quality and data achievable without additional spectrum; co-channel and adjacent channel protection requirements much less than those for FM. System is interleaved to mitigate first adjacent channel issues and is more robust in the presence of co-channel analogue digital interference.</p>	<p>FM stereo quality and data achievable within 100 kHz bandwidth; co-channel and adjacent channel protection requirements much less than those for FM. Further improvement in the efficiency of spectrum use can be achieved by operating multiple transmitters on the same frequency (i.e. SFN single frequency network). Efficiency is especially high in the case of repeaters reusing the same frequency. It can be more efficient by using 16-quadrature amplitude modulation (QAM) carrier modulation besides 4-QAM. (Orthogonal frequency division multiplex (OFDM) with multilevel error correcting coding).</p>	<p>The system defines simulcast mode and all digital mode to meet the different needs at every stage of the digital switch-off. Using simulcast mode, FM stereo (or CD) quality and data achievable without additional spectrum; co-channel and adjacent channel protection requirements are much less than those for FM. System is interleaved to mitigate first adjacent channel interference and is more robust in the presence of co-channel analogue digital interference. After switch-off, the system can make use more spectrum and provide more high quality services (such as several CD quality services and 5.1 multi-channel services).</p>	<p>FM stereo quality and data achievable within 100, 200, 250 kHz bandwidth; co-channel and adjacent channel protection requirements much less than those for FM. Further improvement in the efficiency of spectrum use can be achieved by operating multiple transmitters on the same frequency (i.e. SFN single frequency network). Efficiency is especially high in the case of repeaters reusing the same frequency. High efficiency is achieved by using of orthogonal frequency division multiplex (OFDM) with multilevel error correcting coding and quadrature amplitude modulation (QAM) – 4-QAM, 16-QAM, 64-QAM.</p>

TABLE 1 (continued)

Characteristics from Rec. ITU-R BS.774 (condensed wording)	Digital System A	Digital System F	Digital System C	Digital System G	Digital System H	Digital System I
					<p>Further improvement in the spectrum efficiency can be achieved by multiple transmitters on the same frequency (i.e. SFN single frequency network). Efficiency is especially high in the case of repeaters reusing the same frequency. It can be more efficient by using 16/64-quadrature amplitude modulation (QAM) carrier modulation besides 4-QAM. (Orthogonal frequency division multiplex (OFDM) with multi-level error correcting coding).</p>	



<b>Characteristics from Rec. ITU-R BS.774 (condensed wording)</b>	<b>Digital System A</b>	<b>Digital System F</b>	<b>Digital System C</b>	<b>Digital System G</b>	<b>Digital System H</b>	<b>Digital System I</b>
Performance in multipath and shadowing environments	System is especially designed for multipath operation. It works on the basis of a power summation of echoes falling within a given time interval. This feature allows use of on-channel repeaters to cover terrain shadowed areas	System is especially designed for multipath environment. It works on the basis of a power summation of echoes falling within a given time interval. This feature allows the use of on-channel repeaters to cover terrain shadowed areas	System is especially designed for multipath operation. It is OFDM modulated thereby achieving a high degree of performance in multipath. This feature allows the use of on-channel repeaters to cover terrain shadowed areas	System is especially designed for multipath environment. It works on the basis of a power summation of echoes falling within a given time interval. This feature allows the use of on-channel repeaters to cover terrain shadowed areas	System is especially designed for multipath environment. It works on the basis of a power summation of echoes falling within a given time interval. This feature allows the use of on-channel repeaters to cover terrain shadowed areas	System is especially designed for multipath environment. It works on the basis of a power summation of echoes falling within a given time interval. This feature allows the use of on-channel repeaters to cover terrain shadowed areas
Common receiver signal processing for satellite (S) and terrestrial (T) broadcasting	Not applicable. Terrestrial only	Not applicable. Terrestrial only	Not applicable. Terrestrial only	Not applicable. Terrestrial only	Not applicable. Terrestrial only	Not applicable. Terrestrial only

TABLE 1 (continued)

Characteristics from Rec. ITU-R BS.774 (condensed wording)	Digital System A	Digital System F	Digital System C	Digital System G	Digital System H	Digital System I
Reconfiguration and quality vs. number of programmes tradeoff	Service multiplex is based on 64 sub-channels of capacity varying from 8 kbit/s to about 1 Mbit/s, depending on the error protection level, and is totally reconfigurable in a dynamic fashion. Each sub-channel can also contain an unlimited number of variable capacity data packet channels.	Multiplexing of payload data is based on MPEG-2 systems. Audio data rate can be selected in any step in order to trade off programme audio quality against the number of services. Transmission parameters such as modulation and error correction are dynamically reconfigurable by transmission and multiplexing configuration control (TMCC).	Content bit rate is up to 144 kbit/s. Bits can be dynamically re-allocated to audio or data using the HDC transport functionalities at the discretion of the broadcaster. Within that range, content multiplexing allows up to 8 audio programs and up to 32 data services. The receiver dynamically re-configures to match the transmission mode of operation.	Service multiplex can support up to four streams, the capacity of which can vary according to broadcaster needs and is totally reconfigurable in a dynamic fashion. Each stream may carry audio or data content with the packet size configurable by the broadcaster to maximize efficiency. The receiver dynamically reconfigures to match the transmission mode of operation.	Service multiplex can support up to fifteen streams, the capacity of which can vary according to broadcaster needs and is totally reconfigurable in a dynamic fashion. Each stream may carry audio or data content with the packet size configurable by the broadcaster to maximize efficiency. The receiver can be dynamically reconfigured to match the transmission mode.	Service multiplex can support more than 20 streams, the capacity of which can vary according to broadcaster needs and is totally reconfigurable in a dynamic fashion. Each stream may carry audio, video and/or data content with the packet size configurable by the broadcaster to maximize efficiency. The receiver dynamically reconfigures to match the transmission mode of operation.
Extent of coverage vs. number of programme trade-offs	Five levels of protection for MPEG-2 audio and eight levels of protection for MPEG-4 audio and data services are available through using punctured convolutional coding for each of the 64 sub-channels (forward error correction (FEC) ranges from 1/4 to 3/4)	Four kinds of modulation and five levels of protection are available. (Carrier modulation: differential quaternary phase shift keying (DQPSK), QPSK, 16-QAM, 64-QAM, coding rate: 1/2, 2/3, 3/4, 5/6, 7/8)	The system maintains uniform coverage for all programs. Secondary carriers may have reduced range in presence of adjacent channel interference. (Carrier modulation: QPSK)	Two kinds of modulation (4-QAM, 16-QAM) and different levels of protection (two levels for the SDC and four levels for the MSC) are available. Each stream may be dynamically configured. Forward error correction (FEC) ranges from 1/4 to 5/8)	Three kinds of modulation (4-QAM, 16-QAM and 64-QAM) and different levels of protection (four levels for the MSC) are available. Forward error correction (FEC) ranges from 1/4 to 3/4)	Three kinds of modulation (4-QAM, 16-QAM and 64-QAM) and different levels of protection (three levels for the MSC) are available. Forward error correction (FEC) ranges from 1/2 to 3/4.

TABLE 1 (continued)

<b>Characteristics from Rec. ITU-R BS.774 (condensed wording)</b>	<b>Digital System A</b>	<b>Digital System F</b>	<b>Digital System C</b>	<b>Digital System G</b>	<b>Digital System H</b>	<b>Digital System I</b>
<p>Common receiver for different means of programme delivery – Terrestrial services</p>	<p>Allows local, subnational and national terrestrial services with the same modulation with a single transmitter or multiple transmitters operating in a single frequency network to take advantage of a common receiver</p>	<p>Allows local, subnational and national terrestrial services with the same modulation with a single transmitter or multiple transmitters operating in a single frequency network to take advantage of a common receiver</p>	<p>System uses common antenna and front end that is compatible with existing analogue FM broadcast services. Allows for local service as well as subnational and national terrestrial services with a single transmitter or multiple transmitters operating in a single frequency network in the case of the digital portion of the hybrid mode or the all digital mode. Allows for common delivery of FM programming that makes a seamless transition from digital to analogue and back. Permits simulcasting of identical programming in analogue and digital mode (hybrid operation)</p>	<p>Allows local, subnational and national terrestrial services with the same modulation with a single transmitter or multiple transmitters operating in a single frequency network to take advantage of a common receiver. Designed as a terrestrial digital only system</p>	<p>System uses common antenna and front end that is compatible with the existing analogue FM broadcast services. Allows for local service as well as subnational and national terrestrial services with a single transmitter or multiple transmitters operating within a single frequency network in the case of the digital portion of the simulcast mode or all digital modes</p>	<p>Allows local, subnational and national terrestrial services with the same modulation with a single transmitter or multiple transmitters operating in a single frequency network to take advantage of a common receiver. Designed as a terrestrial digital only system</p>

TABLE 1 (continued)

Characteristics from Rec. ITU-R BS.774 (condensed wording)	Digital System A	Digital System F	Digital System C	Digital System G	Digital System H	
<ul style="list-style-type: none"> <li>– Mixed/hybrid</li> <li>– Cable distribution</li> </ul>	Signal can be carried transparently by cable	Allows the use of the same band as terrestrial sound broadcasting (mixed) as well as the use of terrestrial on-channel repeaters to reinforce the satellite coverage (hybrid) resulting in all these channels being received transparently by a common receiver. Signal can be carried transparently by cable	Signal can be carried transparently by cable	Signal can be carried transparently by cable	Signal can be carried transparently by cable	Signal can be carried transparently by cable

TABLE 1 (continued)

<b>Characteristics from Rec. ITU-R BS.774 (condensed wording)</b>	<b>Digital System A</b>	<b>Digital System F</b>	<b>Digital System C</b>	<b>Digital System G</b>	<b>Digital System H</b>	<b>Digital System I</b>
<p>Programme-associated data (PAD) capability</p>	<p>PAD channel from 0.33 kbit/s to 64 kbit/s capacity is available through a reduction of any audio channel by the corresponding amount. Dynamic label for programme and service identification showing only receiver alphanumeric display is available to all receivers. Basic hypertext markup language (HTML) decoding and Joint Photographic Experts Group (JPEG) picture decoding is available on receivers with graphic displays (1/4 video graphic array (VGA)), etc.</p>	<p>PAD multiplexing is based on MPEG-2 systems</p>	<p>PAD is an integral part of the system and can be provided through opportunistic data without any reduction of audio quality or data channels. Dynamic label for programme and service identification showing on any receiver alphanumeric display is available to all receivers</p>	<p>PAD with broadcaster selected capacity is available. Dynamic label for programme and service identification showing on any receiver alphanumeric display is available to all receivers (DRM TextMessages; programme accompanying labels (Unicode)); Electronic programme guide; advanced text-based information service (Unicode), supporting all classes of receivers, triggers interactivity and geo-awareness; programme accompanying images + animation traffic information small-scale video</p>	<p>PAD with broadcaster selected capacity is available. Dynamic labels for programme and service identification showing on any receiver alphanumeric display are available to all receivers. Electronic programme guide; advanced text-based information service.</p>	<p>PAD with broadcaster selected capacity is available. Dynamic labels for programme and service identification showing on any receiver alphanumeric display are available to all receivers. Electronic programme guide; advanced text-based information service.</p>

TABLE 1 (continued)

<b>Characteristics from Rec. ITU-R BS.774 (condensed wording)</b>	<b>Digital System A</b>	<b>Digital System F</b>	<b>Digital System C</b>	<b>Digital System G</b>	<b>Digital System H</b>	<b>Digital System I</b>
Flexible assignment of services	The multiplex can be dynamically re-configured in a fashion transparent to the user	The multiplex can be dynamically re-configured in a fashion transparent to the user	The system automatically reconfigures between audio and data in a fashion transparent to user	The multiplex can be dynamically reconfigured in a fashion transparent to the user	The multiplex can be dynamically reconfigured in a fashion transparent to the user	The multiplex can be dynamically reconfigured in a fashion transparent to the user
Compatibility of multiplex structure with open system interconnection (OSI)	The system multiplex structure is compliant with the OSI layered model, especially for the data channels, except for the unequal error protection features of the MPEG-2 Layer II audio channel	The system multiplex structure is fully compliant with MPEG-2 systems architecture	The system is based on an OSI layered model including both data and audio except for the unique error protection afforded the audio codec	The system multiplex structure is compliant with the OSI layered model for all services	The system multiplex structure is compliant with the OSI layered model for all services	The system multiplex structure is compliant with the OSI layered model for all services
Value-added data capability	Any sub-channel (out of 64) not used for audio can be used for programme-independent data services	Capacity at any rate up to the full payload capacity can be assigned to independent data for the delivery of business data, paging, still pictures graphics, etc. under conditional access control if desired	Capacity at any rate up to the full payload capacity can be assigned to independent data for the delivery of business data, paging still pictures graphics, etc. under conditional access control if desired	Capacity at any rate up to the full payload capacity can be assigned to independent data for the delivery of business data, paging still pictures graphics, etc. under conditional access control if desired	Capacity at any rate up to the full payload capacity can be assigned to independent data for the delivery of business data, paging still pictures graphics, etc. under conditional access control if desired	Capacity at any rate up to the full payload capacity can be assigned to independent data for the delivery of business data, paging still pictures graphics, etc. under conditional access control if desired

TABLE 1 (end)

Characteristics from Rec. ITU-R BS.774 (condensed wording)	Digital System A	Digital System F	Digital System C	Digital System G	Digital System H	Digital System I
Receiver low-cost manufacturing	Allows for mass-production manufacturing and low-cost consumer receivers	The system was specifically optimized to enable an initial low complexity vehicular receiver deployment. Standardization group has been established to achieve low cost receivers based on large scale integration (LSI) mass production techniques	The system was specifically optimized to enable an initial low complexity vehicular receiver deployment. 3rd generation IC solutions allow for single-chip implementation compatible with low-cost portable receivers and mobile devices.	Allows for mass-production manufacturing and low-cost consumer receivers	Allows for mass-production manufacturing and low-cost consumer receivers	Allows for mass-production manufacturing and low-cost consumer receivers

- (1) Additional information about the HD Codec (HDC) can be found at [www.iberiquity.com](http://www.iberiquity.com).
- (2) The modes implemented in the in-band on-channel (IBOC) chipset (Digital System C) do not support vehicular operation at frequencies above 230 MHz.
- (3) The system was successfully tested in Regions 1 and 3. With respect to Region 2, field test data is not available to demonstrate compatibility with analogue broadcasting in areas with significant co- and adjacent-channel interference.



## Annex 1

### Summaries of Digital Systems

#### 1 Summary of Digital System A

Digital System A, also known as the Eureka 147 digital audio broadcasting (DAB) system, was developed for both satellite and terrestrial broadcasting applications in order to allow a common low-cost receiver to be used. The system has been designed to provide vehicular, portable and fixed reception with low gain omni-directional receive antennas located at 1.5 m above ground. Actually DAB is used for terrestrial broadcasting for portable and mobile reception. It especially offers improved performance in multipath and shadowing environments which are typical of urban reception conditions by the use of on-channel terrestrial repeaters to serve as gap-fillers. Digital System A is capable of offering various levels of sound quality up to high quality sound comparable to that obtained from consumer digital recorded media. It can also offer various data services and different levels of conditional access and the capability of dynamically re-arranging the various services contained in the multiplex.

#### 2 Summary of Digital System F

Digital System F, also known as the ISDB-TSB system, is designed to provide high-quality sound and data broadcasting with high reliability even in mobile reception. The system is also designed to provide flexibility, expandability, and commonality for multimedia broadcasting using terrestrial networks. The system is a rugged system which uses OFDM modulation, two-dimensional frequency-time interleaving and concatenated error correction codes. The OFDM modulation used in the system is called band segmented transmission (BST)-OFDM. The system has commonality with the ISDB-T system for digital terrestrial television broadcasting in the physical layer. The system has a wide variety of transmission parameters such as carrier modulation scheme, coding rates of the inner error correction code, and length of time interleaving. Some of the carriers are assigned to TMCC carriers which transmit the information on the transmission parameters for receiver control. Digital System F can use high compression audio coding methods such as MPEG-2 AAC. And also, the system adopts MPEG-2 systems. It has commonality and interoperability with many other systems which adopt MPEG-2 systems such as ISDB-S, ISDB-T, DVB-S and DVB-T.

#### 3 Summary of Digital System C

Digital System C, also known as the IBOC DSB system, is a fully developed system. The system was designed to provide vehicular<sup>1</sup>, portable, mobile phone and fixed reception using terrestrial transmitters. Although Digital System C can be implemented in unoccupied spectrum, a significant feature of the system is its ability to offer simul-casting of analogue and digital signals in the existing FM broadcasting band. This system feature would allow for a rational transition for existing FM broadcasters seeking to transition from analogue to digital broadcasting. The system offers improved performance in multipath environments resulting in greater reliability than is offered by existing analogue FM operations. Digital System C offers enhanced audio quality comparable to that obtained from consumer digital recorded media. Moreover, the system incorporates flexibility for broadcasters to offer new data-casting services in addition to the enhanced audio programming. In addition, the

---

<sup>1</sup> The modes implemented in the IBOC chipset (Digital System C) do not support vehicular operation at frequencies above 230 MHz.

system allows for allocation of bits between audio and data-casting capacity to maximize the data-casting capabilities.

#### **4 Summary of Digital System G**

Digital System G, also known as the Digital Radio Mondiale (DRM) system, has been developed for terrestrial broadcasting applications in all the frequency bands allocated worldwide for analogue sound broadcasting. It respects the ITU-defined spectrum masks, allowing a smooth transition from analogue to digital broadcasting. The system is designed as a digital-only system. In the bands above 30 MHz, it defines Robustness Mode E (also known as DRM+) to offer audio quality comparable to that obtained from consumer digital recorded media. In addition, Digital System G also offers various data services, including images and electronic programme guides, and the capability of dynamically rearranging the various services contained in the multiplex without loss of audio.

#### **5 Summary of Digital System H**

Digital System H, also known as the Convergent Digital Radio (CDR) system, has been developed for smoothly switch-off from the currently analogue FM to digital radio. The system was designed to provide vehicular, portable and fixed reception using terrestrial transmitters. During simulcast stage, Digital System H can make full use the unoccupied spectrum in currently FM channel, provide several additional digital radio services, the system offers improved performance in multipath environments resulting in greater reliability than is offered by existing analogue FM operations. After switch-off is finished, Digital System H can provide more high quality digital audio services (such as CD quality or 5.1 multichannel services) as well as various data services, and the system also can support the nation-wide coverage by using single frequency network (SFN).

#### **6 Summary of Digital System I**

Digital System I, also known as the RAVIS system (Real-time AudioVisual Information System), has been developed for terrestrial broadcasting applications in all the frequency bands allocated worldwide for analogue FM sound broadcasting. It respects the ITU-defined spectrum masks, allowing a smooth transition from analogue to digital broadcasting. The system is designed as a digital-only system. It offers audio quality comparable to that obtained from consumer digital recorded media or better. In addition, Digital System I also offer video service and various data services, including images and electronic programme guides, and the capability of dynamically rearranging the various services contained in the multiplex.

## **Annex 2**

### **Digital System A**

#### **1 Introduction**

Digital System A is designed to provide high-quality, multi-service digital radio broadcasting for reception by vehicular, portable and fixed receivers. It is designed to operate at any frequency up to 3000 MHz for terrestrial and cable broadcast delivery. The system is also designed as a flexible,

general-purpose ISDB system which can support a wide range of source and channel coding options, sound-programme associated data and independent data services, in conformity with the flexible and broad-ranging service and system requirements given in Recommendations ITU-R BO.789 and ITU-R BS.774, supported by the Digital Sound Broadcasting Handbook and Report ITU-R BS.1203.

This System is a rugged, yet highly spectrum- and power-efficient, sound and data broadcasting system. It uses advanced digital techniques to remove redundancy and perceptually irrelevant information from the audio source signal, then applies closely-controlled redundancy to the transmitted signal for error correction. The transmitted information is then spread in both the frequency and time domains so that a high quality signal is obtained in the receiver, even when working in conditions of severe multipath propagation, whether stationary or mobile. Efficient spectrum utilization is achieved by interleaving multiple programme signals and a special feature of frequency reuse permits broadcasting networks to be extended, virtually without limit, using additional transmitters all operating on the same radiated frequency.

Digital System A was developed by the Eureka 147 DAB Consortium. It has been actively supported by the European Broadcasting Union (EBU). It has seen substantial success in many European countries and digital switchover is planned in Norway in 2017 and in Switzerland between 2020 and 2024. Regular services are also on air in Australia and many trials have been undertaken on all continents. In Annex 2, Digital System A is referred to as "System A". The full system specification is available as European Telecommunications Standard EN 300 401.

## 2 Use of a layered model

The System A is capable of complying with the International Organization for Standardization (ISO) OSI basic reference model described in ISO 7498 (1984). The use of this model is recommended in Recommendation ITU-R BT.807 and Report ITU-R BT.1207, and a suitable interpretation for use with layered broadcasting systems is given in the Recommendation. In accordance with this guidance, the System A will be described in relation to the layers of the model, and the interpretation applied here is illustrated in Table 2.

Descriptions of many of the techniques involved are most easily given in relation to the operation of the equipment at the transmitter, or at the central point of a distribution network in the case of a network of transmitters.

TABLE 2  
Interpretation of the OSI layered model

Name of layer	Description	Features specific to the System
Application layer	Practical use of the System	System facilities Audio quality Transmission modes
Presentation layer	Conversion for presentation	Audio encoding and decoding Audio presentation Service information
Session layer	Data selection	Programme selection Conditional access
Transport layer	Grouping of data	Programme services Main service multiplex Ancillary data Association of data

TABLE 2 (*end*)

Name of layer	Description	Features specific to the System
Network layer	Logical channel	ISO audio frames Programme associated data
Data link layer	Format of the transmitted signal	Transmission frames Synchronization
Physical layer	Physical (radio) transmission	Energy dispersal Convolutional encoding Time interleaving Frequency interleaving Modulation by DQPSK OFDM Radio transmission

The fundamental purpose of System A is to provide sound programmes to the radio listener, so the order of sections in the following description will start from the application layer (use of the broadcast information), and proceed downwards to the physical layer (the means for radio transmission).

### 3 Application layer

This layer concerns the use of System A at the application level. It considers the facilities and audio quality which System A provides and which broadcasters can offer to their listeners, and the different transmission modes.

#### 3.1 Facilities offered by the System

System A provides a signal which carries a multiplex of digital data, and this conveys several programmes at the same time. The multiplex contains audio programme data, and ancillary data comprising PAD, multiplex configuration information (MCI) and service information (SI). The multiplex may also carry general data services which may not be related to the transmission of sound programmes.

In particular, the following facilities are made available to users of the System A:

- the audio signal (i.e. the programme) being provided by the selected programme service;
- the optional application of receiver functions, for example dynamic range control, which may use ancillary data carried with the programme;
- a text display of selected information carried in the SI. This may be information about the selected programme, or about others which are available for optional selection;
- options which are available for selecting other programmes, other receiver functions, and other SI;
- one or more general data services, for example a traffic message channel (TMC).

System A includes facilities for conditional access, and a receiver can be equipped with digital outputs for audio and data signals.

#### 3.2 Audio quality

Within the capacity of the multiplex, the number of programme services and, for each, the presentation format (e.g. stereo, mono, surround-sound, etc.), the audio quality and the degree of error protection (and hence ruggedness) can be chosen to meet the needs of the broadcasters.

The following range of options is available for the audio quality:

- very high quality, with audio processing margin;
- subjectively transparent quality, sufficient for the highest quality broadcasting;
- high quality, equivalent to good FM service quality;
- medium quality, equivalent to good AM service quality;
- speech-only quality.

System A provides full quality reception within the limits of transmitter coverage; beyond these limits reception degrades in a subjectively graceful manner.

## **4 Presentation layer**

This layer concerns the conversion and presentation of the broadcast information.

### **4.1 Audio source encoding**

The original audio source encoding method used by the System is ISO/IEC MPEG-Audio Layer II, given in the ISO Standard 11172-3. This sub-band coding compression system is also known as the MUSICAM system. This audio source encoding was augmented in 1997 by the addition of ISO Standard ISO/IEC 13818-3 which allowed increased subjective quality at low bitrates. In 2007 the DAB+ audio source coding was introduced, standardized as ETSI TS 102 563, which uses the more efficient HE-AACv2 audio codec, standardized as ISO Standard ISO/IEC 14496-3. This audio source coding option is now the preferred choice of broadcasters launching System A services, and many broadcasters who began services with MPEG-2 audio have moved to using MPEG-4 audio to increase the spectrum efficiency of their output.

System A accepts a number of PCM audio signals at a sampling rate of 16, 24, 32 or 48 kHz, each with the option of additional programme associated data (PAD/XPAD). The number of possible audio sources depends on the bit rate and the error protection profile. The audio encoders can work at bit rates from 8 to 192 kbit/s per monophonic channel. In stereophonic or dual channel mode, the encoder produces twice the bit rate of a mono channel.

### **4.2 Audio decoding**

Decoding in the receiver is straightforward and economical using a simple signal processing technique, requiring only de-multiplexing, expanding and inverse-filtering operations.

### **4.3 Audio presentation**

Audio signals may be presented monophonically or stereophonically, or audio channels may be grouped for surround-sound. Programmes may be linked to provide the same programme simultaneously in a number of different languages. In order to satisfy listeners in both hi-fi and noisy environments, the broadcaster can optionally transmit a dynamic range control (DRC) signal which can be used in the receiver in a noisy environment to compress the dynamic range of the reproduced audio signal. Note that this technique can also be beneficial to listeners with impaired hearing.

### **4.4 Presentation of service information**

With each programme transmitted by the system, the following elements of SI can be made available for display on a receiver:

- basic programme label (i.e. the name of the programme);
- time and date;

- cross-reference to the same, or similar programme (e.g. in another language) being transmitted in another ensemble or being simulcast by an AM or FM service;
- extended service label for programme-related services;
- programme information (e.g. the names of performers);
- language;
- programme type (e.g. news, sport, music, etc.).

Transmitter network data can also be included for internal use by broadcasters.

## **5 Session layer**

This layer concerns the selection of, and access to, broadcast information.

### **5.1 Programme selection**

In order that a receiver can gain access to any or all of the individual services with a minimum overall delay, information about the current and future content of the multiplex is carried by the FIC. This information is the MCI, which is machine-readable data. Data in the FIC are not time-interleaved, so the MCI is not subject to the delay inherent in the time-interleaving process applied to audio and general data services. However, these data are repeated frequently to ensure their ruggedness. When the multiplex configuration is about to change, the new information, together with the timing of the change is sent in advance in the MCI.

The user of a receiver can select programmes on the basis of textual information carried in the SI, using the programme service name, the programme type identity or the language. The selection is then implemented in the receiver using the corresponding elements of the MCI.

If alternative sources of a chosen programme service are available and an original digital service becomes untenable, then linking data carried in the SI (i.e. the “cross reference”) may be used to identify an alternative (e.g. on an FM service) and switch to it. However, in such a case, the receiver will switch back to the original service as soon as reception is possible.

### **5.2 Conditional access**

Provision is made for both synchronization and control of conditional access.

Conditional access can be applied independently to the service components, services or the whole multiplex.

## **6 Transport layer**

This layer concerns the identification of groups of data as programme services, the multiplexing of data for those services and the association of elements of the multiplexed data.

### **6.1 Programme services**

A programme service generally comprises an audio service component and optionally additional audio and/or data service components, provided by one service provider. The whole capacity of the multiplex may be devoted to one service provider (e.g. a national public broadcaster), or it may be divided amongst several service providers (e.g. a group of independent commercial, public and community broadcasters).

## 6.2 Main service multiplex

The data representing each of the programmes being broadcast (digital audio data with some ancillary data, and maybe also general data) are subjected to convolutional encoding (see § 9.2) and time-interleaving, both for error protection. Time-interleaving improves the ruggedness of data transmission in a changing environment (e.g. reception by a moving vehicular receiver) and imposes a predictable transmission delay. The interleaved and encoded data are then fed to the main service multiplexer where, each 24 ms, the data are gathered in sequence into the multiplex frame. The combined bit stream output from the multiplexer is known as the MSC which has a gross capacity of 2.3 Mbit/s. Depending on the chosen code rate (which can be different from one service component to another), this gives a net bit rate ranging from approximately 0.8 to 1.7 Mbit/s, through a 1.5 MHz bandwidth. The main service multiplexer is the point at which synchronized data from all of the programme services using the multiplex are brought together.

General data may be sent in the MSC as an unstructured stream or organized as a packet multiplex where several sources are combined. The data rate may be any multiple of 8 kbit/s, synchronized to the system multiplex, subject to sufficient total multiplex capacity, taking into account the demand for audio services.

The FIC is external to the MSC and is not time-interleaved.

## 6.3 Ancillary data

There are two areas where ancillary data may be carried within the system multiplex:

- there is special provision for a moderate amount of PAD to be carried within each audio channel;
- all remaining ancillary data are treated as a separate service within the MSC. The presence of this information is signalled in the MCI.

## 6.4 Association of data

A precise description of the current and future content of the MSC is provided by the MCI, which is carried by the FIC. Essential items of SI which concern the content of the MSC (i.e. for programme selection) must also be carried in the FIC. More extensive text, such as a list of all the day's programmes, must be carried separately as a general data service. Thus, the MCI and SI contain contributions from all of the programmes being broadcast.

The PAD, carried within each audio channel, comprises mainly the information which is intimately linked to the sound programme and therefore cannot be sent in a different data channel which may be subject to a different transmission delay. This data may be simple text or images related to the programme content, advance programme guide information, or other data applications related to the audio content.

## 7 Network layer

This layer concerns the identification of groups of data as programmes.

### 7.1 ISO audio frames

The processes in the audio source encoder are carried out during ISO audio frames of various durations which may be multiplexed into audio super frames that fit with the system frame duration of 24 ms (i.e. 24 ms, 48 ms and 120 ms). The bit allocation, which varies from frame to frame, and the scale factors are coded and multiplexed with the sub-band samples in each ISO audio frame. The frame packing unit assembles the actual bit stream from the output data of the quantizer and coding



unit, and adds other information, such as header information, CRC words for error detection, and PAD, which travel along with the coded audio signal. Each audio channel contains a PAD channel having a variable capacity, which can be used to convey information which is intimately linked to the sound programme.

## 8 Data link layer

This layer provides the means for receiver synchronization.

### 8.1 The transmission frame

In order to facilitate receiver synchronization, the transmitted signal is built up with a regular frame structure (see Fig. 1). The transmission frame comprises a fixed sequence of symbols. The first is a null symbol to provide a coarse synchronization (when no RF signal is transmitted), followed by a fixed reference symbol to provide a fine synchronization, automatic gain control (AGC), automatic frequency control (AFC) and phase reference functions in the receiver; these symbols make up the synchronization channel. The next symbols are reserved for the FIC, and the remaining symbols provide the MSC. The total frame duration  $T_F$  is 96 ms. The details of the transmission mode are given in Table 3.

FIGURE 1  
Multiplex frame structure

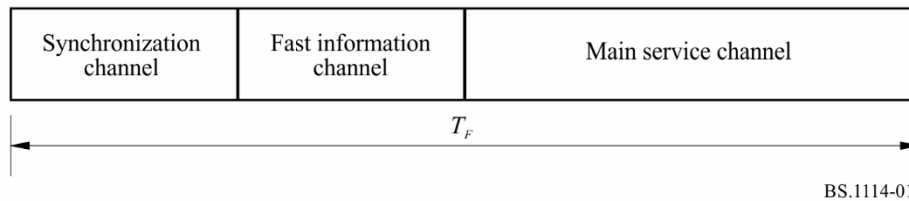

TABLE 3

Transmission parameters of System A

Transmission frame duration, $T_F$	96 ms
Null symbol duration, $T_{NULL}$	1.297 ms
Duration of OFDM symbols, $T_s$	1.246 ms
Inverse of the carrier spacing, $T_u$	1 ms
Duration of the time interval called guard interval, $\Delta$ ( $T_s = T_u + \Delta$ )	246 $\mu$ s
Number of transmitted carriers, $K$	1 536

Each audio service within the MSC is allotted a fixed time slot in the frame.

## 9 The physical layer

This layer concerns the means for radio transmission (i.e. the modulation scheme and the associated error protection).

### 9.1 Energy dispersal

In order to ensure appropriate energy dispersal in the transmitted signal, the individual sources feeding the multiplex are scrambled.

### 9.2 Convolutional encoding

Convolutional encoding is applied to each of the data sources feeding the multiplex to ensure reliable reception. The encoding process involves adding deliberate redundancy to the source data bursts (using a constraint length of 7). This gives “gross” data bursts.

In the case of a DAB audio signal (MPEG-2), greater protection is given to some source-encoded bits than others, following a preselected pattern known as the unequal error protection (UEP) profile. The average code rate, defined as the ratio of the number of source-encoded bits to the number of encoded bits after convolutional encoding, may take a value from  $1/3$  (the highest protection level) to  $3/4$  (the lowest protection level). Different average code rates can be applied to different audio sources, subject to the protection level required and the bit rate of the source-encoded data. For example, the protection level of audio services carried by cable networks may be lower than that of services transmitted in radio-frequency channels.

DAB+ audio signals (MPEG-4) and general data services are convolutionally encoded using one of a selection of uniform rates which may take values from  $1/4$  to  $3/4$ . Data in the FIC are encoded at a constant  $1/3$  rate.

### 9.3 Time interleaving

Time interleaving with an interleaving depth of 16 frames is applied to the convolutionally encoded data in order to provide further assistance to a mobile receiver.

### 9.4 Frequency interleaving

In the presence of multipath propagation, some of the carriers are enhanced by constructive signals, while others suffer destructive interference (frequency selective fading). Therefore, the system provides frequency interleaving by a rearrangement of the digital bit stream amongst the carriers, such that successive source samples are not affected by a selective fade. When the receiver is stationary, the diversity in the frequency domain is the prime means to ensure successful reception.

### 9.5 Modulation by 4-DPSK OFDM

System A uses DQPSK OFDM. This scheme meets the exacting requirements of high bit-rate digital broadcasting to mobile, portable and fixed receivers, especially in multipath environments.

The basic principle consists of dividing the information to be transmitted into a large number of bit streams having low bit rates individually, which are then used to modulate individual carriers. The corresponding symbol duration becomes larger than the delay spread of the transmission channel. In the receiver any echo shorter than the guard interval will not cause intersymbol interference but rather contribute positively to the received power (see Fig. 2). The large number  $K$  of carriers is known collectively as an ensemble.

FIGURE 2  
Constructive contribution of echoes

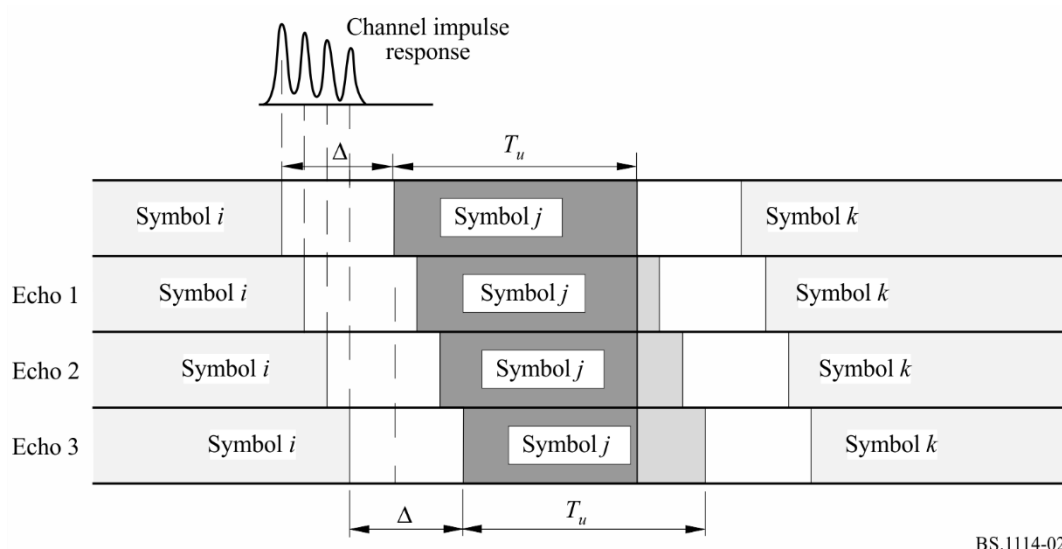

In the presence of multipath propagation, some of the carriers are enhanced by constructive signals, while others suffer destructive interference (frequency selective fading). Therefore, System A includes a redistribution of the elements of the digital bit stream in time and frequency, such that successive source samples are affected by independent fades. When the receiver is stationary, the diversity in the frequency domain is the only means to ensure successful reception; the time diversity provided by time-interleaving does not assist a static receiver. For System A, multipath propagation is a form of space-diversity and is considered to be a significant advantage, in stark contrast to conventional FM or narrow-band digital systems where multipath propagation can completely destroy a service.

In any system able to benefit from multipath, the larger the transmission channel bandwidth, the more rugged the system. In System A, an ensemble bandwidth of 1.5 MHz was chosen to secure the advantages of the wideband technique, as well as to allow planning flexibility. Table 3 also indicates the number of OFDM carriers within this bandwidth.

A further benefit of using OFDM is that high spectrum and power efficiency can be obtained with single frequency networks for large area coverage and also for dense city area networks. Any number of transmitters providing the same programmes may be operated on the same frequency, which also results in an overall reduction in the required operating powers. As a further consequence distances between different service areas are significantly reduced.

Because echoes contribute to the received signal, all types of receiver (i.e. portable, home and vehicular) may utilize simple, non-directional antennas.

## 9.6 Transmission signal spectrum of System A

As an example, the theoretical spectrum of System A is illustrated in Fig. 3.

FIGURE 3

Theoretical transmission signal spectrum for transmission Mode II of System A

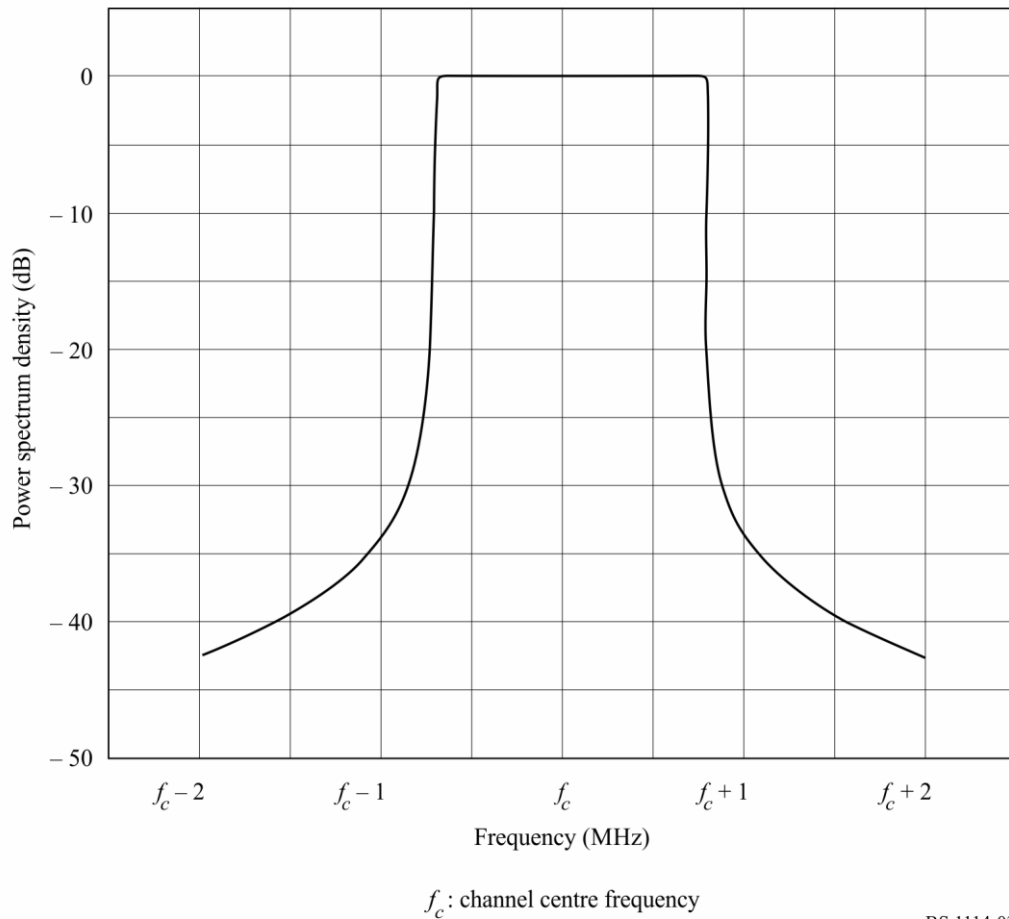

The out-of-band radiated signal spectrum in any 4 kHz band should be constrained by one of the masks defined in Fig. 4 (see also Table 4).

FIGURE 4  
Out-of-band spectrum masks for a transmission signal of System A

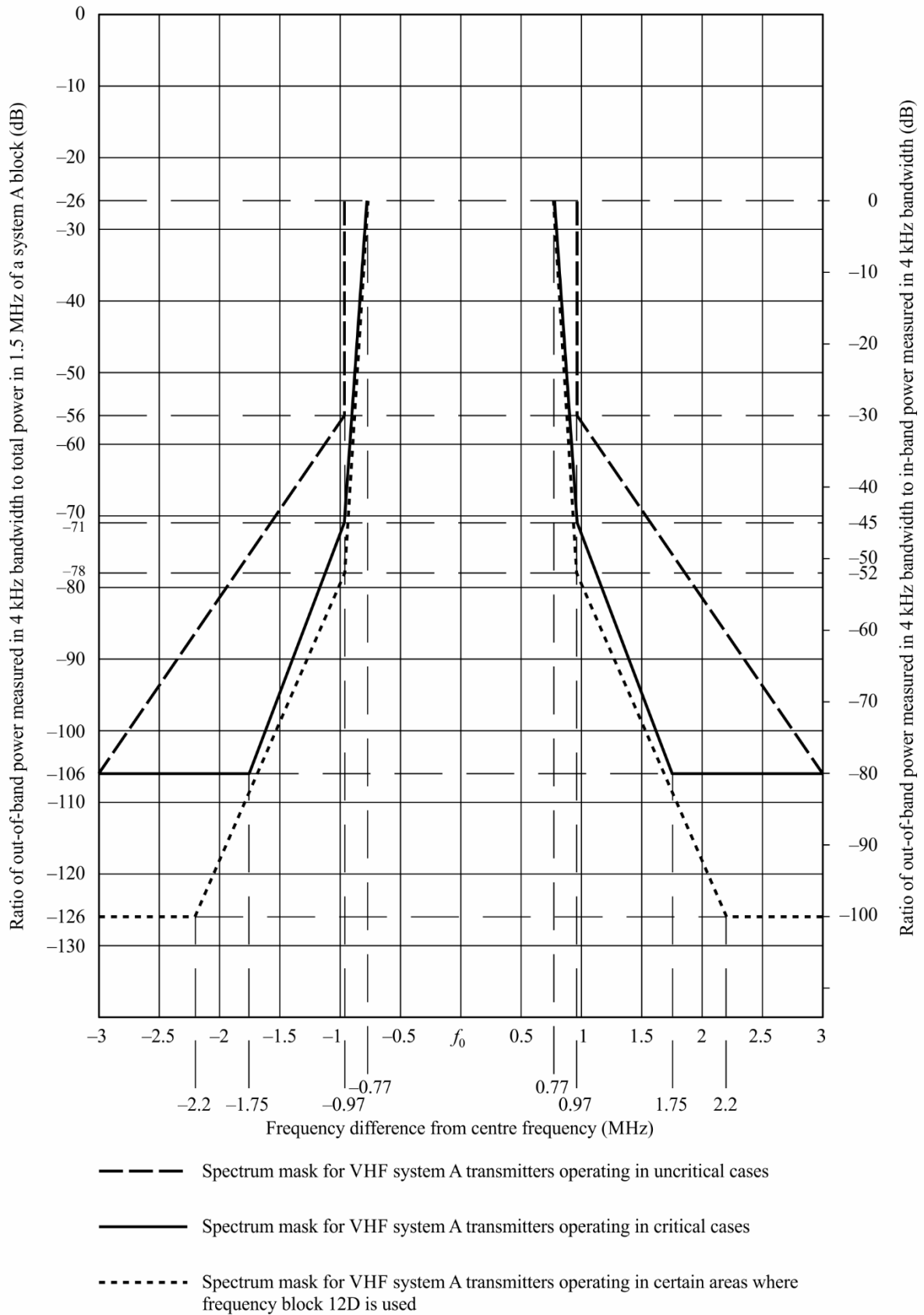

The solid line mask should apply to VHF transmitters operating in critical cases. The dashed line mask should apply to VHF transmitters operating in uncritical cases and the dotted line mask should apply to VHF transmitters operating in certain areas where frequency block 12D is used.

The level of the signal at frequencies outside the normal 1.536 MHz bandwidth can be reduced by applying an appropriate filtering.

TABLE 4  
Out-of-band spectrum table for a transmission signal of System A

	Frequency relative to the centre of the 1.54 MHz channel (MHz)	Relative level (dB)
Spectrum mask for VHF System A transmitters operating in uncritical cases	$\pm 0.97$	-26
	$\pm 0.97$	-56
	$\pm 3.0$	-106
Spectrum mask for VHF System A transmitters operating in critical cases	$\pm 0.77$	-26
	$\pm 0.97$	-71
	$\pm 1.75$	-106
	$\pm 3.0$	-106
Spectrum mask for VHF System A transmitters operating in certain areas where frequency block 12D is used	$\pm 0.77$	-26
	$\pm 0.97$	-78
	$\pm 2.2$	-126
	$\pm 3.0$	-126

## 10 RF performance characteristics of System A

RF evaluation tests have been carried out on System A at 226 MHz for a variety of conditions representing mobile and fixed reception. Measurements of bit error ratio (BER) vs.  $S/N$  in the transmission channel were made on a data channel using the following conditions:

$$D = 64 \text{ kbit/s}, \quad R = 0.5$$

$$D = 24 \text{ kbit/s}, \quad R = 0.375$$

where:

$D$ : source data rate

$R$ : average channel code rate.

### 10.1 BER vs. $S/N$ (in 1.5 MHz) in a Gaussian channel

Additive, Gaussian white noise was added to set the  $S/N$  at the input of the receiver. The results are shown in Fig. 5. As an example, for  $R = 0.5$ , the measured results in Fig. 5 can be compared with those from a software simulation, to show the inherent performance of the system. It can be seen that an implementation margin of less than 1.0 dB is obtained at a BER of  $1 \times 10^{-4}$ .

FIGURE 5  
**BER vs. S/N for System A**  
**Gaussian channel**

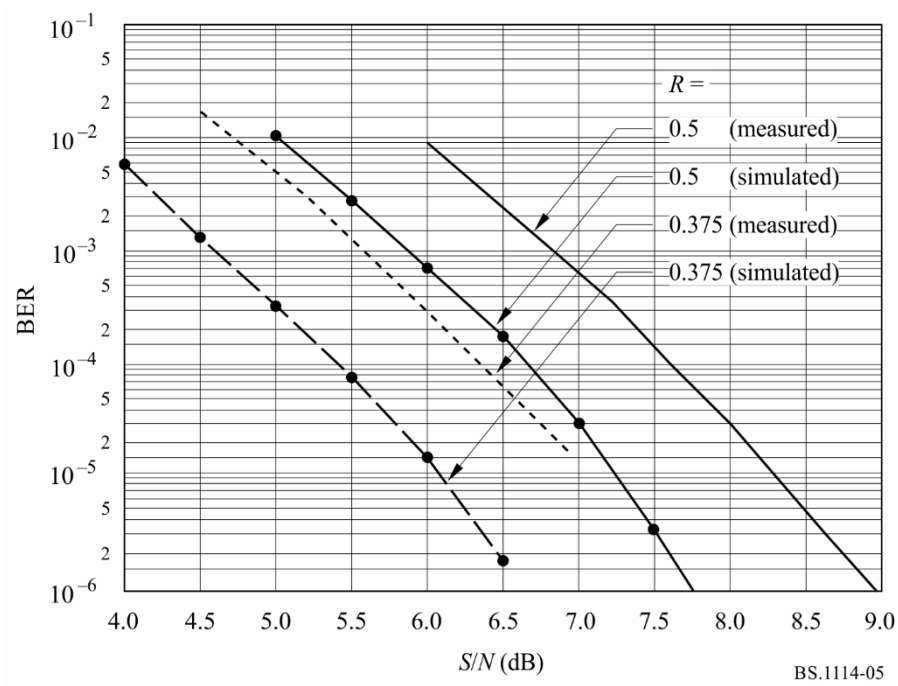

**10.2 BER vs. S/N (in 1.5 MHz) in a Rayleigh channel simulated in urban environment**

Measurements of BER vs. S/N were made on the data channels, using a fading channel simulator. The Rayleigh channel simulations correspond to Fig. 6 in Cost 207 documentation (typical urban area, 0-0.5 μs) and the receiver travelling at a speed of 15 km/h.

The results are shown in Fig. 6.



FIGURE 6

**BER vs.  $S/N$  for System A  
(Transmission Mode I, 226 MHz)**

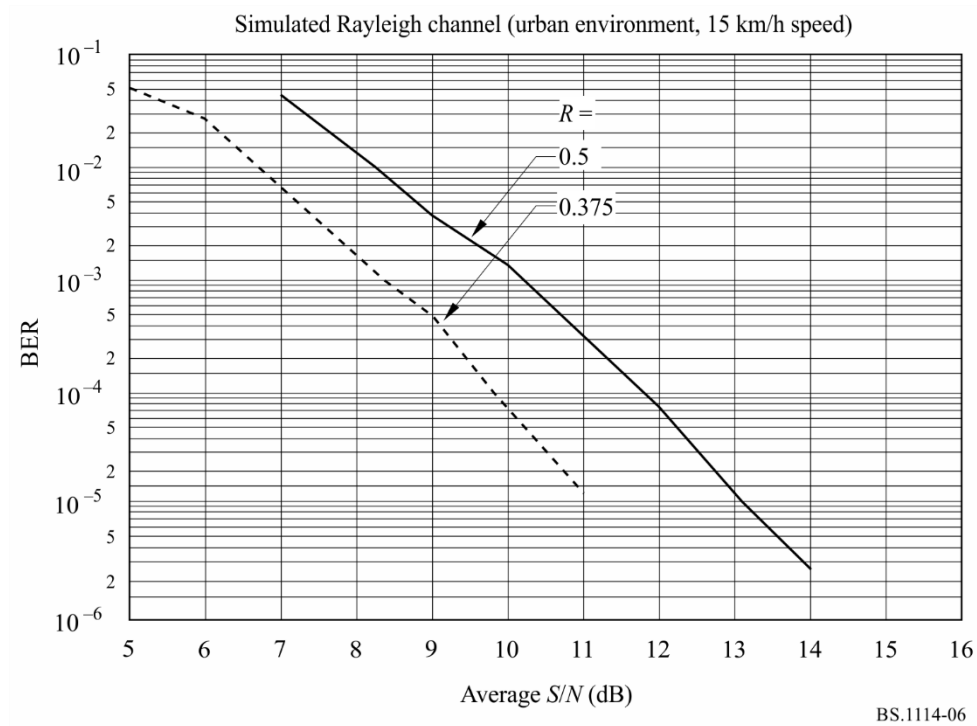

### 10.3 BER vs. $S/N$ (in 1.5 MHz) in a Rayleigh channel simulated in rural environment

Measurements of BER vs.  $S/N$  were made on the data channels using a fading channel simulator. The Rayleigh channel simulations correspond to Fig. 6 in Cost 207 documentation (rural area, non-hilly, 0-5  $\mu$ s) and the receiver travelling at 130 km/h. The results are shown in Fig. 7.

FIGURE 7

**BER vs. S/N for System A**  
(Transmission Mode I, 226 MHz)

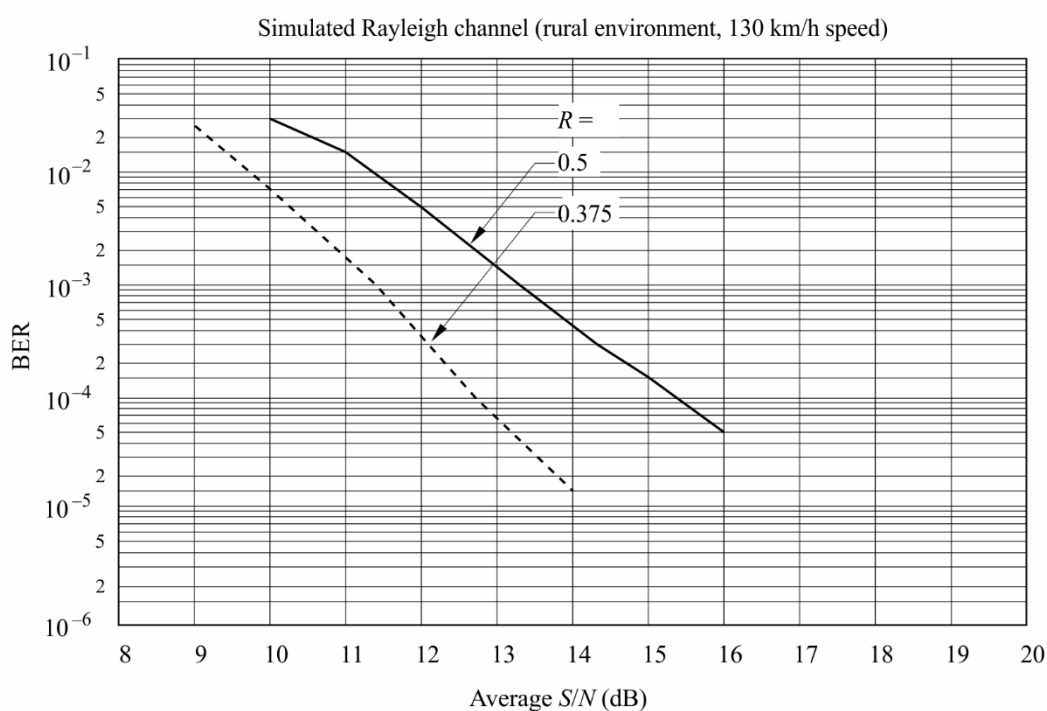

## Annex 3

### Digital System F

#### 1 Introduction

Digital System F (System F), also known as the ISDB-T<sub>SB</sub> system, is designed to provide high-quality sound and data broadcasting with high reliability even in mobile reception. System F is also designed to provide flexibility, expandability, and commonality for multimedia broadcasting using terrestrial networks, and conform to system requirements given in Recommendation ITU-R BS.774.

System F is a rugged system which uses OFDM modulation, two-dimensional frequency-time interleaving and concatenated error correction codes. The OFDM modulation used in System F is called band segmented transmission (BST)-OFDM. System F has commonality with the ISDB-T system for digital terrestrial television broadcasting in the physical layer. The bandwidth of an OFDM block called OFDM-segment is approximately 500 kHz. System F consists of one or three OFDM-segments, therefore the bandwidth of the system is approximately 500 kHz or 1.5 MHz.

System F has a wide variety of transmission parameters such as carrier modulation scheme, coding rates of the inner error correction code, and length of time interleaving. Some of the carriers are assigned to control carriers which transmit the information on the transmission parameters. These control carriers are called TMCC carriers.

System F can use high compression audio coding methods such as MPEG-2 Layer II, AC-3 and MPEG-2 AAC. Also, the system adopts MPEG-2 systems. It has commonality and interoperability with many other systems which adopt MPEG-2 systems such as ISDB-S, ISDB-T, DVB-S and DVB-T.

Figure 8 shows the ISDB-T<sub>SB</sub> and full-band ISDB-T transmission concept and its reception.

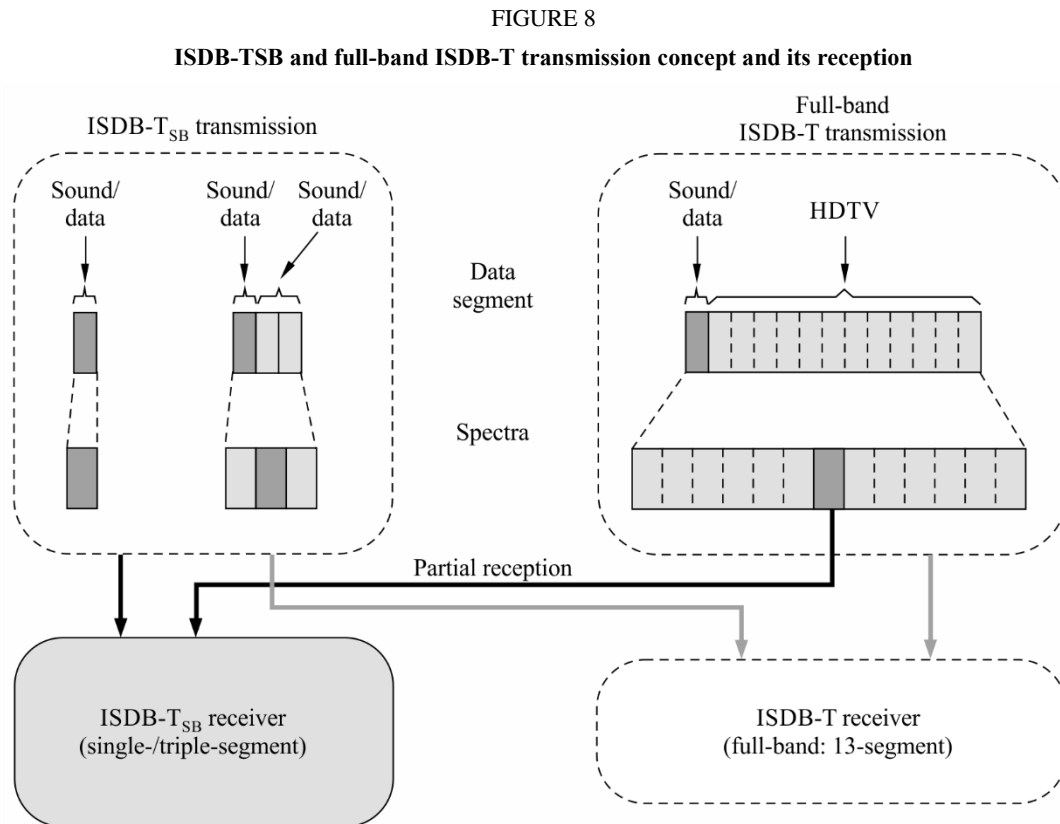

HDTV: High definition television

BS.1114-08

## 2 Features of System F

### 2.1 Ruggedness of System F

System F uses OFDM modulation, two-dimensional frequency-time interleaving and concatenated error correction codes. OFDM is a multi-carrier modulation method, and it is a multipath-proof modulation method, especially adding a guard interval in the time domain. The transmitted information is spread in both the frequency and time domains by interleaving, and then the information is corrected by the Viterbi and Reed-Solomon (RS) decoder. Therefore a high quality signal is obtained in the receiver, even when working in conditions of severe multipath propagation, whether stationary or mobile.

### 2.2 Wide variety of transmission

System F adopts BST-OFDM, and consists of one or three OFDM-segments. That is single-segment transmission and triple-segment transmission. A bandwidth of OFDM-segment is defined in one of three ways depending on the reference channel raster of 6, 7 or 8 MHz. The bandwidth is a fourteenth of the reference channel bandwidth (6, 7 or 8 MHz), that is, 429 kHz (6/14 MHz), 500 kHz

(7/14 MHz) or 571 kHz (8/14 MHz). The bandwidth of OFDM-segment should be selected in compliance with the frequency situation in each country.

The bandwidth of single-segment is around 500 kHz, therefore the bandwidth of single-segment transmission and triple-segment transmission is approximately 500 kHz and 1.5 MHz.

System F has three alternative transmission modes which allow the use of a wide range of transmitting frequencies, and four alternative guard interval lengths for the design of the distance between SFN transmitters. These transmission modes have been designed to cope with Doppler spread and delay spread, for mobile reception in presence of multipath echoes.

### **2.3 Flexibility**

System F multiplex structure is fully compliant with MPEG-2 systems architecture. Therefore various digital contents such as sound, text, still picture and data can be transmitted simultaneously.

In addition, according to the broadcaster's purpose, they can select the carrier modulation method, error correction coding rate, length of time interleaving, etc. of the system. There are four kinds of carrier modulation method of DQPSK, QPSK, 16-QAM and 64-QAM, five kinds of coding rate of 1/2, 2/3, 3/4, 5/6 and 7/8, and five kinds of time interleaving length from 0 to approximately 1 s. The TMCC carrier transmits the information to the receiver indicating the kind of modulation method and coding rate that are used in the system.

### **2.4 Commonality and interoperability**

System F uses BST-OFDM modulation and adopts MPEG-2 systems. Therefore the system has commonality with the ISDB-T system for digital terrestrial television broadcasting (DTTB) in the physical layer, and has commonality with the systems such as ISDB-T, ISDB-S, DVB-T and DVB-S which adopt MPEG-2 Systems in the transport layer.

### **2.5 Efficient transmission and source coding**

System F uses a highly-spectrum efficient modulation method of OFDM. Also, it permits frequency reuse broadcasting networks to be extended using additional transmitters all operating on the same radiated frequency.

In addition, the channels of independent broadcasters can be transmitted together without guardbands from the same transmitter as long as the frequency and bit synchronization are kept the same between the channels.

System F can adopt MPEG-2 AAC. Near CD quality can be realized at a bit rate of 144 kbit/s for stereo.

### **2.6 Independency of broadcasters**

System F is a narrow-band system for transmission of one sound programme at least. Therefore broadcasters can have their own RF channel in which they can select transmission parameters independently.

### **2.7 Low-power consumption**

Almost all devices can be made small and light weight by developing LSI chips. The most important aspect of efforts to reduce battery size is that the power consumption of a device must be low. The slower the system clock, the lower the power consumption. Therefore, a narrow-band, low bit rate system like single-segment transmission can allow for the receiver to be both portable and lightweight.

## 2.8 Hierarchical transmission and partial reception

In the triple-segment transmission, both one layer transmission and hierarchical transmission can be achieved. There are two layers of A and B in the hierarchical transmission. The transmission parameters of carrier modulation scheme, coding rates of the inner code and a length of the time interleaving can be changed in the different layers.

The centre segment of hierarchical transmission is able to be received by single-segment receiver. Owing to the common structure of an OFDM segment, a single-segment receiver can partially receive a centre segment of full-band ISDB-T signal whenever an independent program is transmitted in the centre segment.

Figure 9 shows an example of hierarchical transmission and partial reception.

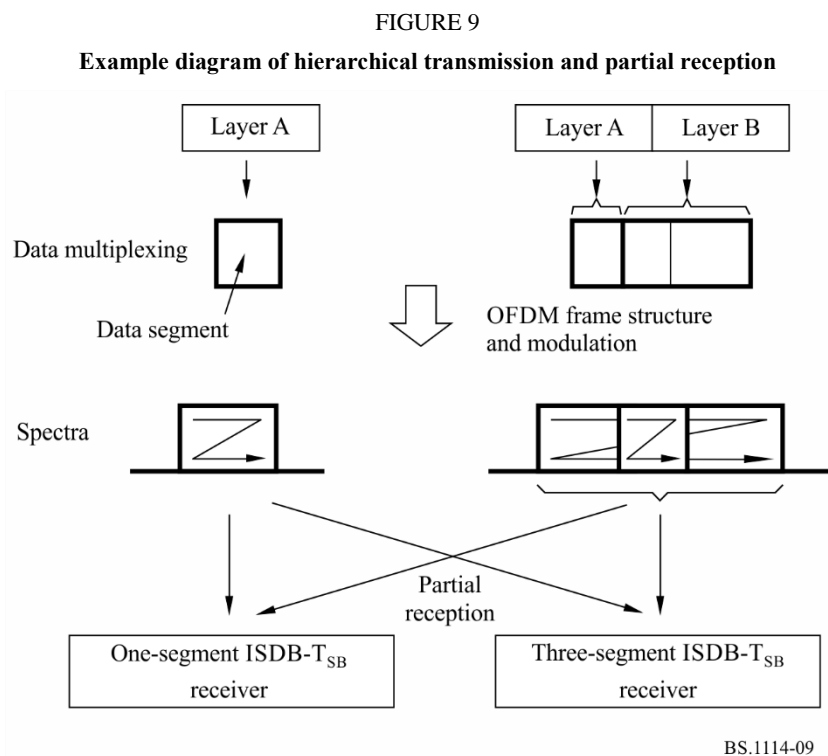

## 3 Transmission parameters

System F can be assigned to 6 MHz, 7 MHz or 8 MHz channel raster. Segment bandwidth is defined to be a fourteenth of channel bandwidth, therefore that is 429 kHz (6/14 MHz), 500 kHz (7/14 MHz) or 571 kHz (8/14 MHz). However, the segment bandwidth should be selected in compliance with the frequency situation in each country.

The transmission parameters for the ISDB-T<sub>SB</sub> system are shown in Table 5.

TABLE 5  
Transmission parameters for the ISDB-Tsb

Mode		Mode 1	Mode 2	Mode 3
Total number of segments <sup>(1)</sup> ( $N_s = n_d + n_c$ )		1, 3		
Reference channel raster ( $BW_f$ ) (MHz)		6, 7, 8		
Segment bandwidth ( $BW_s$ ) (kHz)		$BW_f \times 1000/14$		
Used bandwidth ( $BW_u$ ) (kHz)		$BW_s \times N_s + C_s$		
Number of segments for differential modulation		$n_d$		
Number of segments for coherent modulation		$n_c$		
Carrier spacing ( $C_s$ ) (kHz)		$BW_s/108$	$BW_s/216$	$BW_s/432$
Number of carriers	Total	$108 \times N_s + 1$	$216 \times N_s + 1$	$432 \times N_s + 1$
	Data	$96 \times N_s$	$192 \times N_s$	$384 \times N_s$
	SP <sup>(2)</sup>	$9 \times n_c$	$18 \times n_c$	$36 \times n_c$
	CP <sup>(2)</sup>	$n_d + 1$	$n_d + 1$	$n_d + 1$
	TMCC <sup>(3)</sup>	$n_c + 5 \times n_d$	$2 \times n_c + 10 \times n_d$	$4 \times n_c + 20 \times n_d$
	AC1 <sup>(4)</sup>	$2 \times N_s$	$4 + N_s$	$8 \times N_s$
	AC2 <sup>(4)</sup>	$4 \times n_d$	$9 \times n_d$	$19 \times n_d$
Carrier modulation		DQPSK, QPSK, 16-QAM, 64-QAM		
Number of symbol per frame		204		
Useful symbol duration ( $T_u$ ) ( $\mu$ s)		$1000/C_s$		
Guard interval duration ( $T_g$ )		$1/4, 1/8, 1/16$ or $1/32$ of $T_u$		
Total symbol duration ( $T_s$ )		$T_u + T_g$		
Frame duration ( $T_f$ )		$T_s \times 204$		
FFT samples ( $F_s$ )		$256 (N_s = 1)$ $512 (N_s = 3)$	$512 (N_s = 1)$ $1024 (N_s = 3)$	$1024 (N_s = 1)$ $2048 (N_s = 3)$
FFT sample clock ( $F_{sc}$ ) (MHz)		$F_{sc} = F_s/T_u$		
Inner code		Convolutional code (Coding rate = $1/2, 2/3, 3/4, 5/6, 7/8$ ) (Mother code = $1/2$ )		
Outer code		(204,188) RS code		
Time interleave parameter ( $I$ )		0, 4, 8, 16, 32	0, 2, 4, 8, 16	0, 1, 2, 4, 8
Length of time interleaving		$I \times 95 \times T_s$		

FFT: fast Fourier transform

- (1) System F uses 1 or 3 segments for sound services, while any number of segments may be used for other services such as television services. (Compare with System C of Recommendation ITU-R BT.1306.)
- (2) SP (scattered pilot), and CP (continual pilot) can be used for frequency synchronization and channel estimation. The number of CP includes CPs on all segments and a CP for higher edge of whole bandwidth.
- (3) TMCC carries information on transmission parameters.
- (4) AC (auxiliary channel) carries ancillary information for network operation.

## 4 Source coding

System F multiplex structure is fully compliant with MPEG-2 systems architecture, therefore MPEG-2 transport stream packets (TSPs) containing compressed digital audio signal can be transmitted. Digital audio compression methods such as MPEG-2 Layer II audio specified in ISO/IEC 13818-3, AC-3 (Digital Audio Compression Standard specified in ATSC Document A/52) and MPEG-2 AAC specified in ISO/IEC 13818-7 can be applied to System F.

## 5 Multiplexing

The multiplex of System F is compatible with MPEG-2 TS ISO/IEC 13818-1. In addition, multiplex frame and TMCC descriptors are defined for hierarchical transmission with single TS.

Considering maximum interoperation among a number of digital broadcasting systems, e.g. ISDB-S recommended in Recommendation ITU-R BO.1408, ISDB-T recommended in Recommendation ITU-R BT.1306 (System C) and broadcasting-satellite service (sound) system using the 2.6 GHz band recommended in Recommendation ITU-R BO.1130 (System E), these systems can exchange broadcasting data streams with other broadcasting systems through this interface.

### 5.1 Multiplex frame

To achieve hierarchical transmission using the BST-OFDM scheme, the ISDB-T<sub>SB</sub> system defines a multiplex frame of TS within the scope of MPEG-2 systems. In the multiplex frame, the TS is a continual stream of 204-byte RS-TSP composed of 188-byte TSP and 16 bytes of null data or RS parity.

The duration of the multiplex frame is adjusted to that of the OFDM frame by counting RS-TSPs using a clock that is two times faster than the inverse FFT (IFFT) sampling clock in the case of single-segment transmission. In the case of the triple-segment transmission the duration of the multiple frame is adjusted to that of the OFDM frame by counting RS-TSPs using a clock that is four times faster than the IFFT sampling clock.

## 6 Channel coding

This section describes the channel coding block, which receives the packets arranged in the multiplex frame and passes the channel-coded blocks forward to the OFDM modulation block.

### 6.1 Functional block diagram of channel coding

Figure 10 shows the functional block diagram of channel coding of the ISDB-T<sub>SB</sub> system.

The duration of the multiplex frame coincides with the OFDM frame by counting the bytes in the multiplex frame using a faster clock than IFFT-sampling rate described in the previous section.

At the interface between the multiplex block and the outer coding block, the head byte of the multiplex frame (corresponding to the sync-byte of TSP) is regarded as the head byte of the OFDM frame. In bit-wise description, the most significant bit of the head byte is regarded as the synchronization bit of OFDM frame.

For the triple-segment layered transmission, the RS-TSP stream is divided into two layers in accordance with the transmission-control information. In each layer, coding rate of the inner error correction code, carrier-modulation scheme, and time-interleaving length can be specified independently.



FIGURE 10  
Channel coding diagram

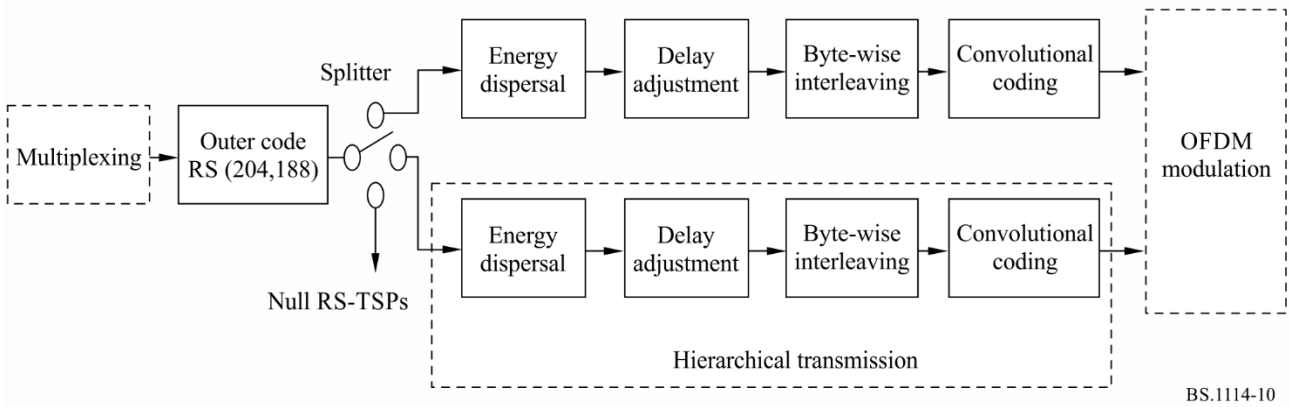

**6.2 Outer coding**

RS (204,188) shortened code is applied to each MPEG-2 TSP to generate an error protected TSP that is RS-TSP. The RS (208,188) code can correct up to eight random erroneous bytes in a received 204-byte word.

Field generator polynomial:  $p(x) = x^8 + x^4 + x^3 + x^2 + 1$

Code generator polynomial:  $g(x) = (x - \lambda^0)(x - \lambda^1)(x - \lambda^2)(x - \lambda^3) \dots (x - \lambda^{15})$

where  $\lambda = 02_h$

It should be noted that null TSPs from the multiplexer are also coded to RS (204,188) packets.

MPEG-2 TSP and RS-TSP (RS error protected TSP) are shown in Fig. 11. RS error protected TSP is also called transmission TSP.

FIGURE 11  
MPEG-2 TSP and RS-TSP (transmission TSP)

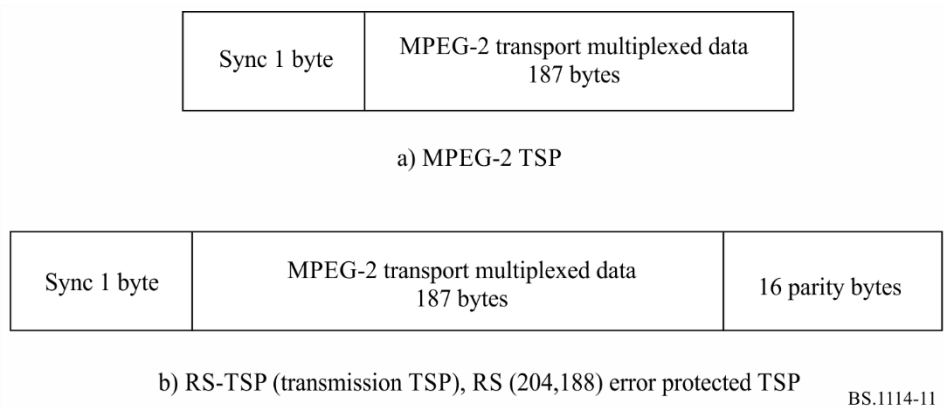

**6.3 Energy dispersal**

In order to ensure adequate binary transitions, the data from the splitter is randomized with pseudo-random binary sequence (PRBS).

The polynomial for the PRBS generator shall be:

$$g(x) = x^{15} + x^{14} + 1$$

#### 6.4 Delay adjustment

In the byte-wise interleaving, the delay caused in the interleaving process differs from stream to stream of different layers depending on its properties (i.e. modulation and channel coding). In order to compensate for the delay difference including de-interleaving in the receiver, the delay adjustment is carried out prior to the byte-wise interleaving on the transmission side.

#### 6.5 Byte-wise interleaving (inter-code interleaving)

Convolutional byte-wise interleaving with length of  $I = 12$  is applied to the 204-byte error protected and randomized packets. The interleaving may be composed of  $I = 12$  branches, cyclically connected to the input byte-stream by the input switch. Each branch  $j$  shall be a first-in first-out (FIFO) shift register, with length of  $j \times 17$  bytes. The cells of the FIFO shall contain 1 byte, and the input and output switches shall be synchronized.

The de-interleaving is similar, in principle, to the interleaving, but the branch indices are reversed. Total delay caused by interleaving and de-interleaving is  $17 \times 11 \times 12$  bytes (corresponding to 11 TSPs).

#### 6.6 Inner coding (convolutional codes)

System F shall allow for a range of punctured convolutional codes, based on a mother convolutional code of rate  $1/2$  with 64 states. Coding rates of the codes are  $1/2$ ,  $2/3$ ,  $3/4$ ,  $5/6$  and  $7/8$ . This will allow selection of the most appropriate property of error correction for a given service or data rate in the ISDB-T<sub>SB</sub> services including mobile services. The generator polynomials of the mother code are  $G_1 = 171_{\text{oct}}$  for X output and  $G_2 = 133_{\text{oct}}$  for Y output.

### 7 Modulation

Configuration of the modulation block is shown in Figs 12 and 13. After bit-wise interleaving, data of each layer are mapped to the complex domain.

#### 7.1 Delay adjustment for bit interleave

Bit interleave causes the delay of 120 complex data ( $I + jQ$ ) as described in the next section. By adding proper delay, total delay in transmitter and receiver is adjusted to the amount of two OFDM symbols.

#### 7.2 Bit interleaving and mapping

One of the carrier modulation schemes among DQPSK, QPSK, 16-QAM and 64-QAM is selectable for this System. The serial bit-sequence at the output of the inner coder is converted into a 2-bit parallel sequence to undergo  $\pi/4$ -shift DQPSK mapping or QPSK mapping, by which  $n$  bits of I-axis and Q-axis data are delivered. The number  $n$  may depend on the hardware implementation. In the case of 16-QAM, the sequence is converted into a 4-bit parallel sequence. In 64-QAM, it is converted into a 6-bit parallel sequence. After the serial-to-parallel conversion, bit-interleaving is carried out by inserting maximum 120-bit delay.

#### 7.3 Data segment

Data segment is defined as a table of addresses for complex data, on which rate conversion, time interleaving, and frequency interleaving shall be executed. The data segment corresponds to the data portion of OFDM segment.

FIGURE 12  
Modulation block diagram

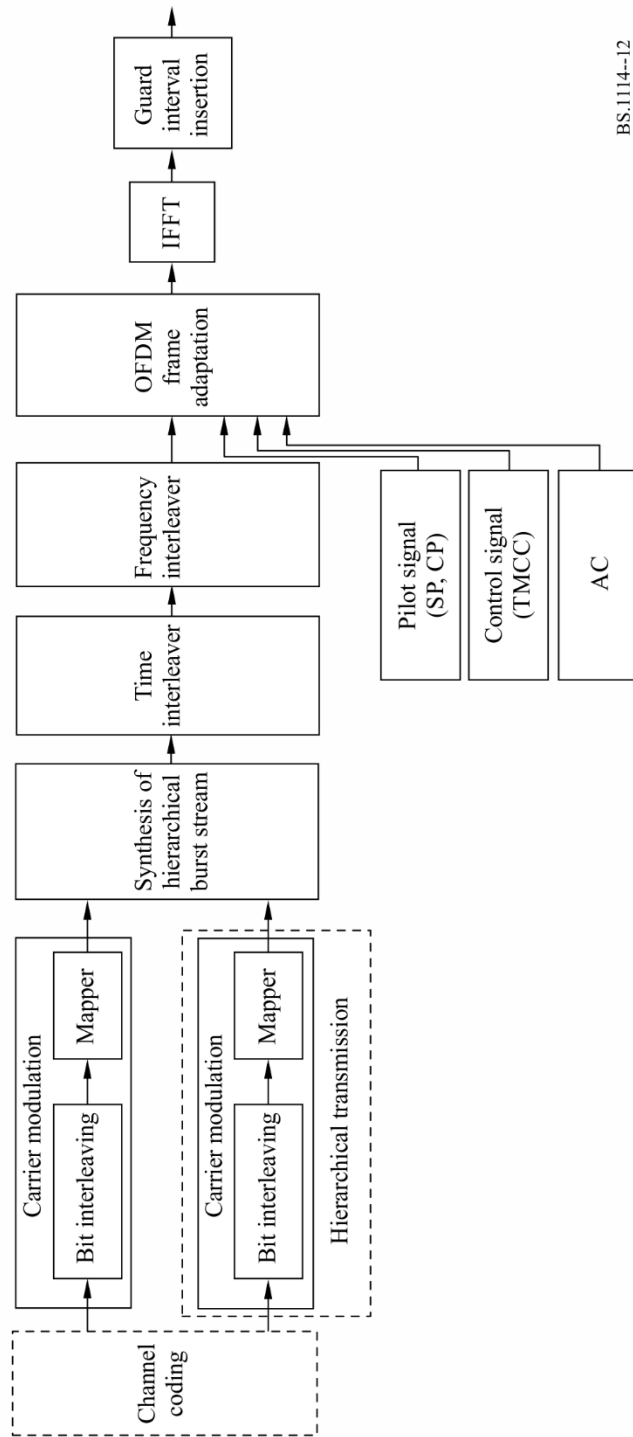

BS.1114-12

FIGURE 13

Configuration of carrier modulation block

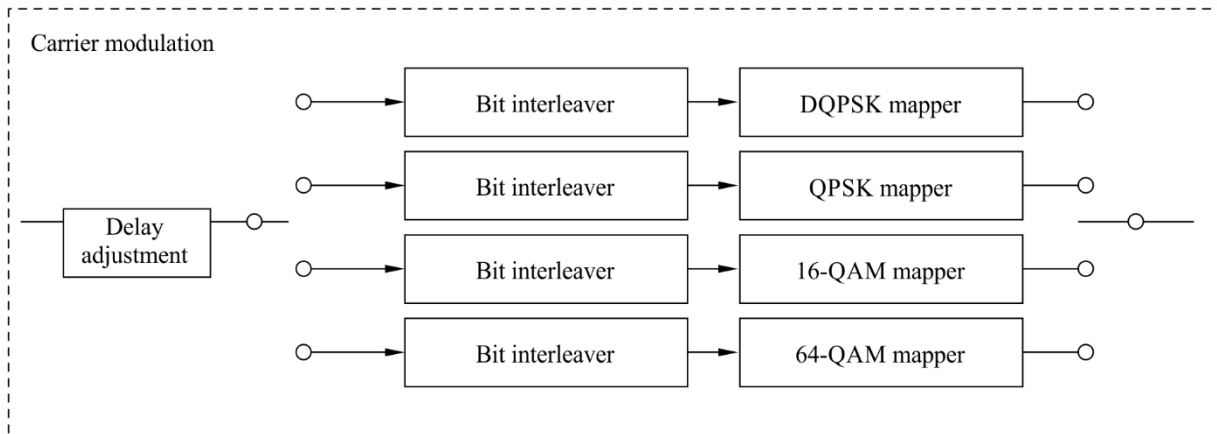

BS.1114-13

#### 7.4 Synthesis of layer-data streams

After being channel-coded and mapped, complex data of each layer are inputted every one symbol to pre-assigned data-segments.

The data stored in all data segments are cyclically read with the IFFT-sample clock; then rate conversions and synthesis of layer data streams are carried out.

#### 7.5 Time interleaving

After synthesis, symbol-wise time interleaving is carried out. The length of time-interleaving is changeable from 0 to approximately 1 s, and shall be specified for each layer.

#### 7.6 Frequency interleaving

Frequency interleaving consists of inter-segment frequency interleaving, intra-segment carrier rotation, and intra-segment carrier randomization. Inter-segment frequency interleaving is taken among the segments having the same modulation scheme. Inter-segment frequency interleaving can be carried out only for triple-segment transmission. After carrier rotation, carrier randomization is performed depending on the randomization table.

#### 7.7 OFDM segment-frame structure

Data segments are arranged into OFDM segment-frame every 204 symbols by adding pilots such as CP, SP, TMCC and AC. The modulation phase of CP is fixed at every OFDM symbol. SP is inserted in every 12 carriers and in every 4 OFDM symbols in the case of coherent modulation method. The TMCC carrier carries transmission parameters such as carrier modulation, coding rate and time interleaving for the receiver control. The AC carrier carries the ancillary information.

### 8 Spectrum mask

The radiated signal spectrum of single-segment transmission for 6/14 MHz segment system should be constrained by the mask defined in Fig. 14 and Table 6. The level of the signal at frequencies outside the 429 kHz bandwidth (6/14 MHz) can be reduced by applying an appropriate filtering.

FIGURE 14  
**Spectrum mask for single-segment ISDB-TSB signal**  
 (segment bandwidth = 6/14 MHz)

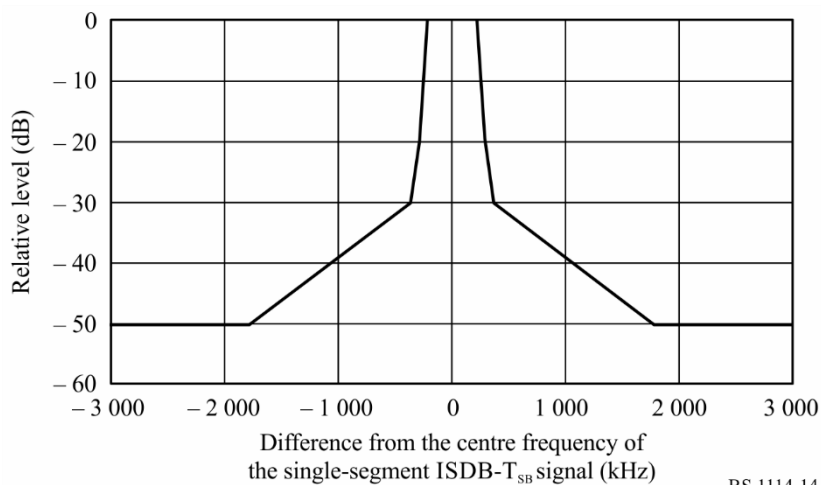

BS.1114-14

TABLE 6  
**Breakpoints of the spectrum mask for the single-segment transmission**  
 (segment bandwidth = 6/14 MHz)

Frequency difference from the centre frequency of the transmitted signal (kHz)	Relative level (dB)
±220	0
±290	-20
±360	-30
±1 790	-50

NOTE 1 – The radiated signal spectrum is measured by the spectrum analyser. A resolution bandwidth of the spectrum analyser should be set to 10 kHz or 3 kHz. Concerning the video bandwidth, it is between 300 Hz and 30 kHz, and video averaging is desirable. The frequency span is set to the minimum value required for measuring the transmission spectrum mask.

Figure 15 and Table 7 define the spectrum mask of triple-segment transmission for 6/14 MHz segment system.

NOTE 1 – The spectrum mask of 7/14 MHz and 8/14 MHz segment systems should be modified in accordance with the spectrum shape of its system.

FIGURE 15

Spectrum mask for triple-segment ISDB-T<sub>SB</sub> signal  
(segment bandwidth = 6/14 MHz)

TABLE 7

Breakpoints of the spectrum mask for the triple-segment  
transmission (segment bandwidth = 6/14 MHz)

Difference from the centre frequency of the terrestrial digital sound signal (kHz)	Relative level (dB)
±650	0
±720	-20
±790	-30
±2 220	-50

## 9 RF performance characteristics

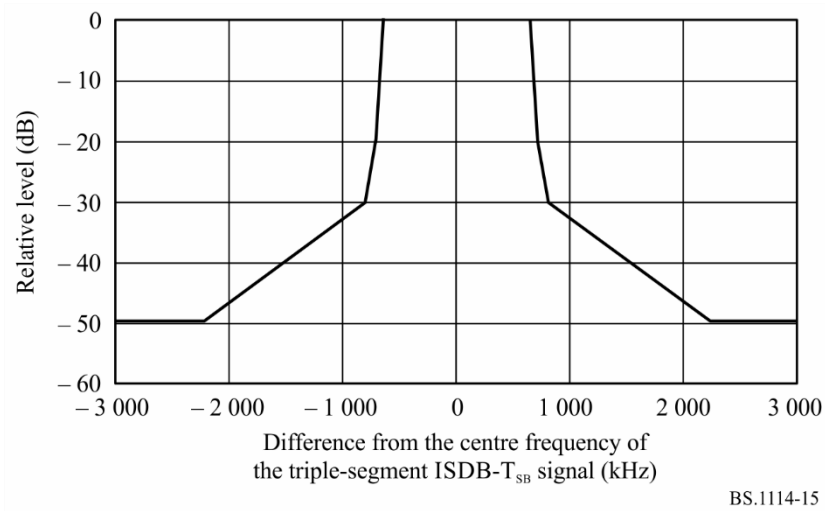
RF evaluation tests have been carried out on the ISDB-T<sub>SB</sub> system for a variety of transmission conditions. The results of laboratory tests are described in this section.

Laboratory transmission experiments for BER performance against random noise and multipath fading were conducted. Measurements of BER vs.  $C/N$  in the transmission channel were made under the following conditions (see Table 8).

### 9.1 BER vs. $C/N$ in a Gaussian channel

Additive white Gaussian noise was added to set the  $C/N$  at the input of the receiver. The results are shown in Figs 16, 17 and 18. These Figures can be compared with those obtained from computer simulation to show the inherent performance of the system. It can be seen that an implementation margin loss of less than 1 dB was obtained at a BER of  $2 \times 10^{-4}$  before RS decoding.

TABLE 8  
**Transmission parameters for laboratory tests**

Number of segments	1 (bandwidth: 429 kHz)
Transmission mode	3 (useful symbol duration: 1.008 ms)
Number of carriers	433
Carrier modulations	DQPSK, 16-QAM, and 64-QAM
Guard interval	63 $\mu$ s (guard interval ratio: 1/16)
Coding rates of inner code	1/2, 2/3, 3/4, and 7/8
Time interleaving	0 and 407 ms

FIGURE 16

**BER before RS decoding vs. C/N**

(Transmission mode: 3, carrier modulation: DQPSK, time interleaving: 407 ms): Gaussian channel

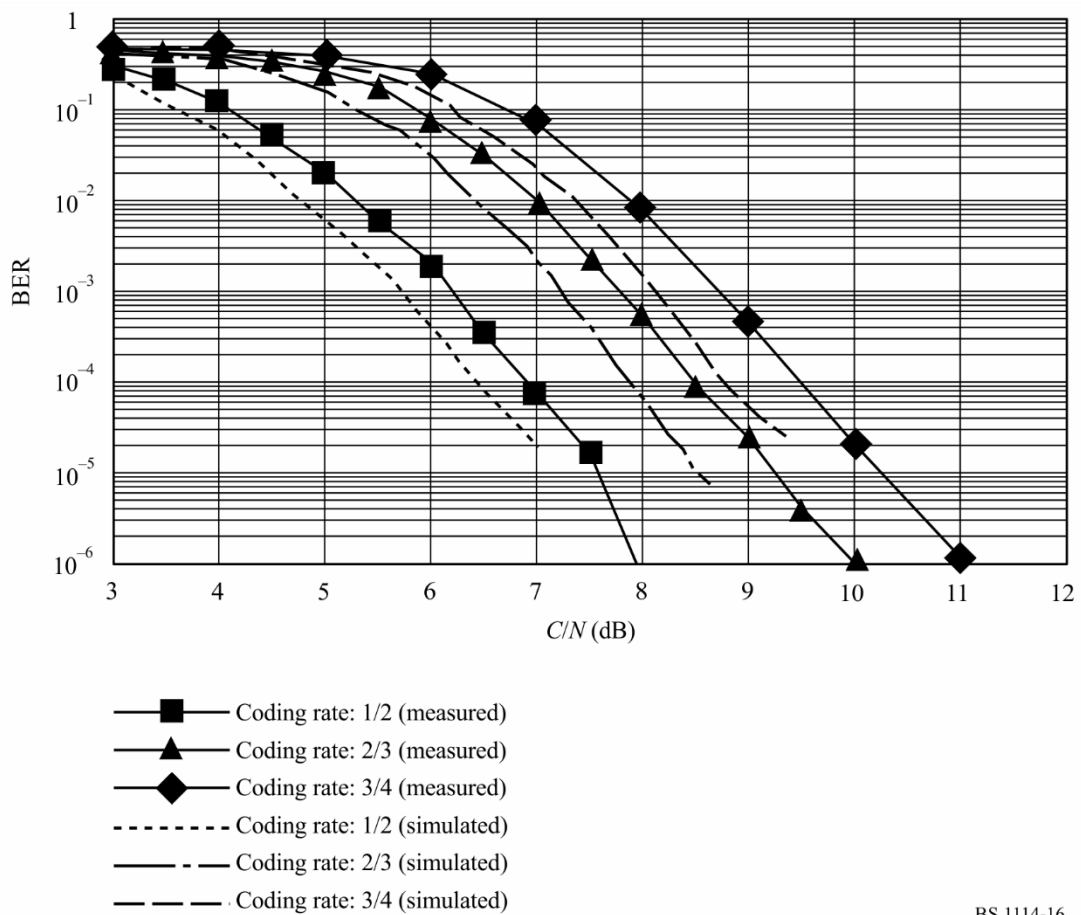
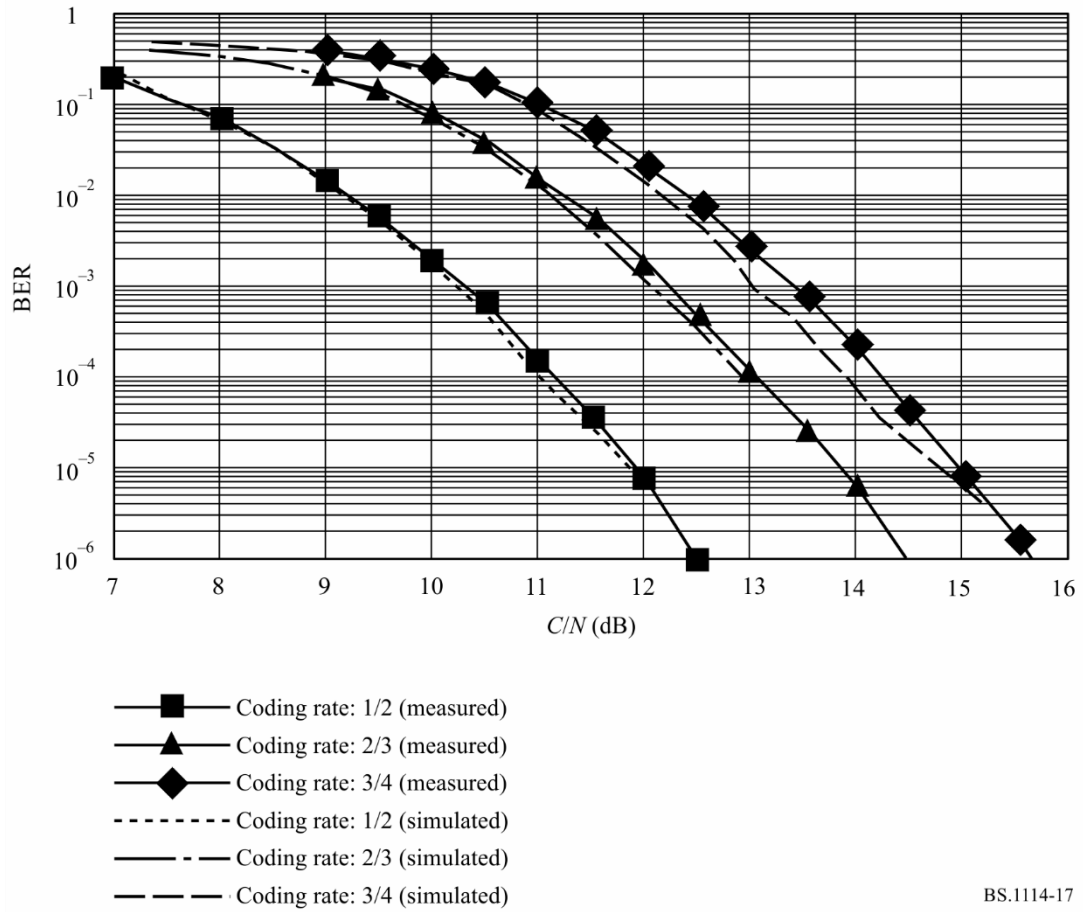

FIGURE 17

BER before RS decoding vs.  $C/N$ 

(Transmission mode: 3, carrier modulation: 16-QAM, time interleaving: 407 ms): Gaussian channel



BS.1114-17



FIGURE 18

BER before RS decoding vs.  $C/N$

(Transmission mode: 3, carrier modulation: 64-QAM, time interleaving: 407 ms): Gaussian channel

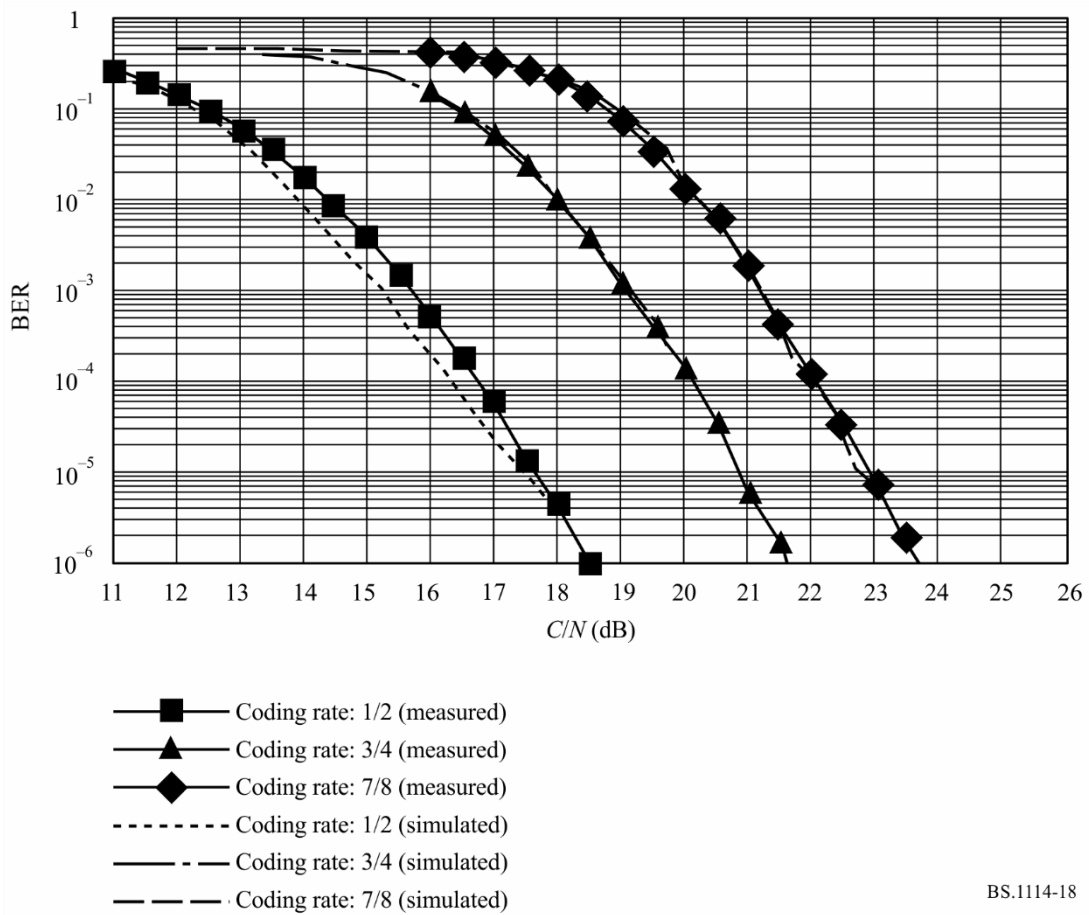

BS.1114-18

**9.2 BER vs.  $C/N$  in a multipath channel**

Measurements of BER vs.  $C/N$  were made using a multipath channel simulator. The desired signal level to undesired or interfering signal level ratio  $D/U$  of the main signal and a delay signal were set to 3 and 10 dB. The delay time of a delayed signal relative to the main signal was set to 15  $\mu$ s. The results are shown in Fig. 19.

FIGURE 19

BER before RS decoding vs.  $C/N$   
 (Transmission mode: 3, coding rate: 1/2, time interleaving: 407 ms): multipath channel

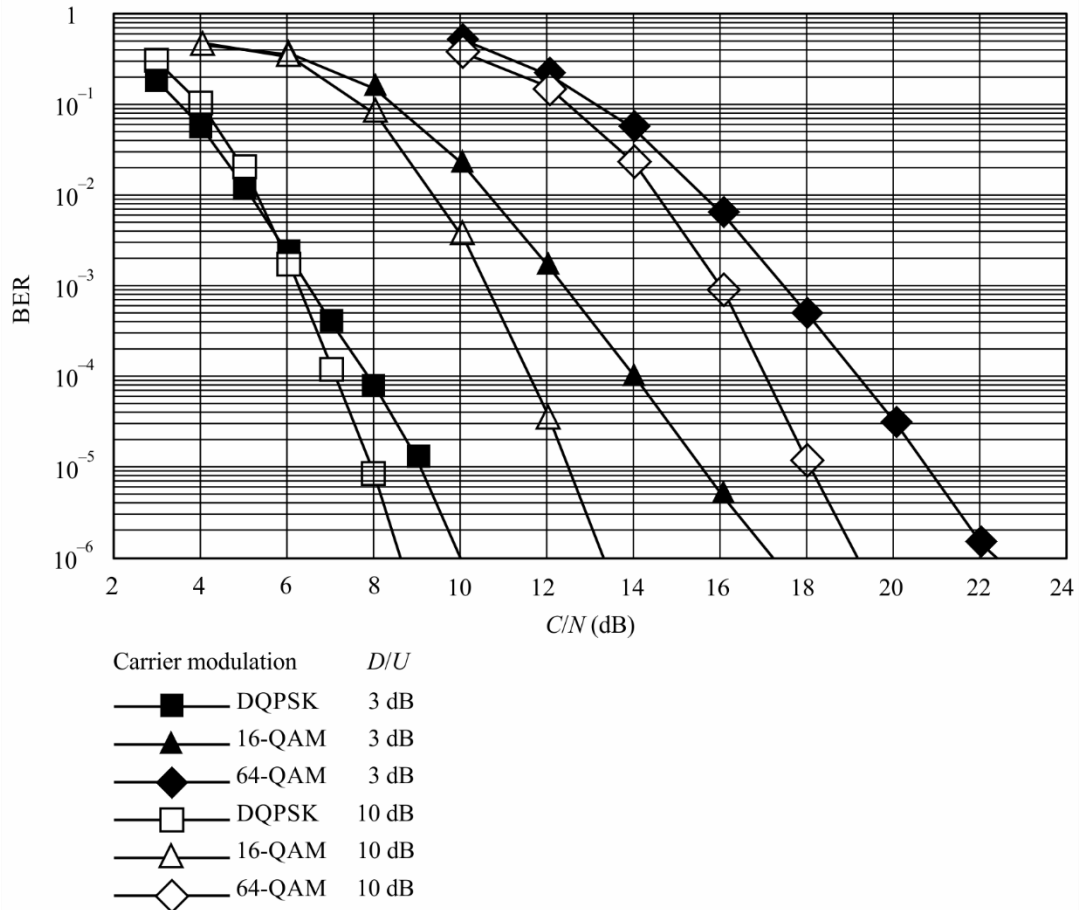

BS.1114-19

### 9.3 BER vs. $C/N$ in a Rayleigh channel

Measurements of BER vs.  $C/N$  were made using a fading channel simulator. The channel was set to two-path Rayleigh fading channel, and the  $D/U$  of the two paths was set to 0 dB. The time of the delayed signal was set to 15  $\mu$ s. The maximum Doppler frequencies of the signal were set to 5 and 20 Hz. The results are shown in Fig. 20.

FIGURE 20

BER before RS decoding vs. C/N

(Transmission mode: 3, carrier modulation: DQPSK, coding rate: 1/2): 2-path Rayleigh channel

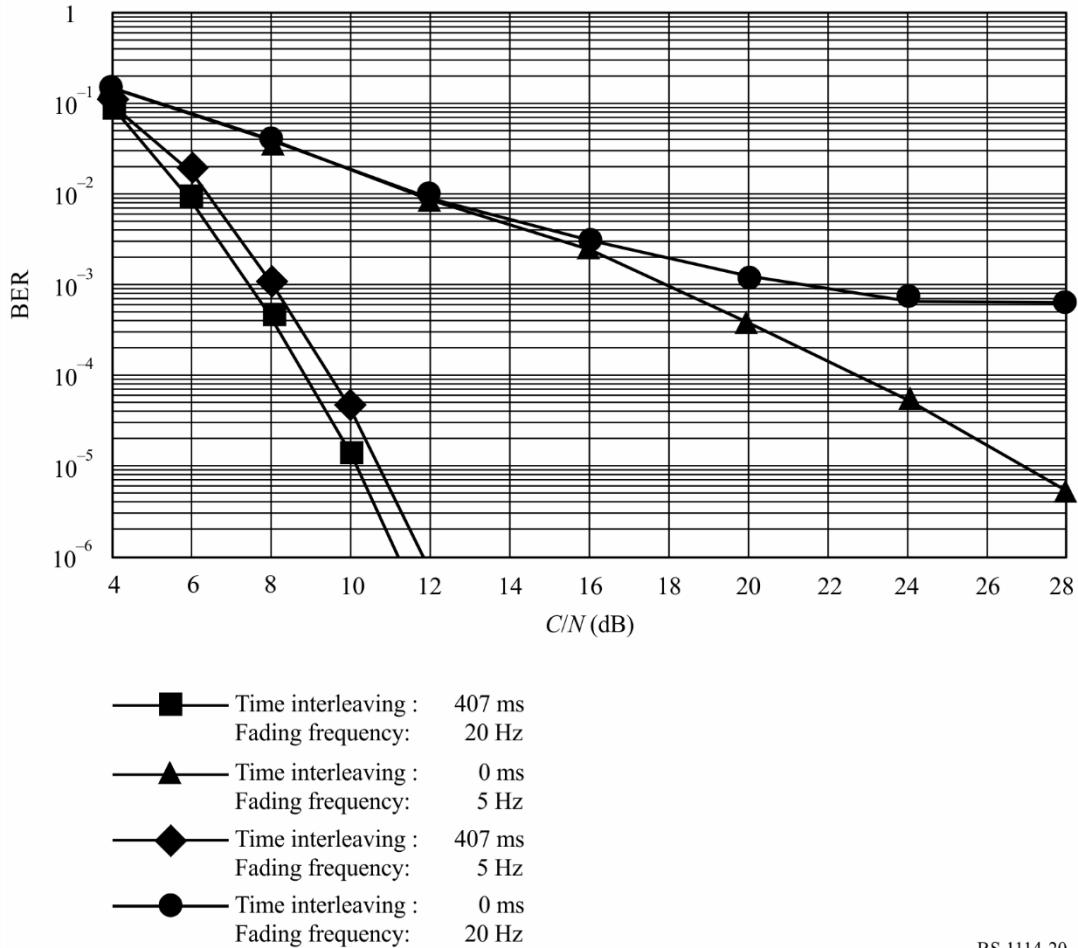

BS.1114-20

## Annex 4

### Digital System C

#### 1 System overview

Digital System C employs IBOC technology to facilitate the introduction of DSB. It offers broadcasters the ability to upgrade their analogue service by adding new audio and data services, providing enhanced audio fidelity, and supporting improved signal robustness. IBOC technology allows broadcasters to introduce these upgrades without the need for new spectrum allocations for the digital signals. IBOC also allows existing stations to broadcast the same programming in analogue and digital. This provides a spectrally efficient means to make a rational transition from the existing analogue environment to a digital future. The IBOC broadcasting system overview is shown in Fig. 21.

FIGURE 21  
 IBOC broadcasting system overview

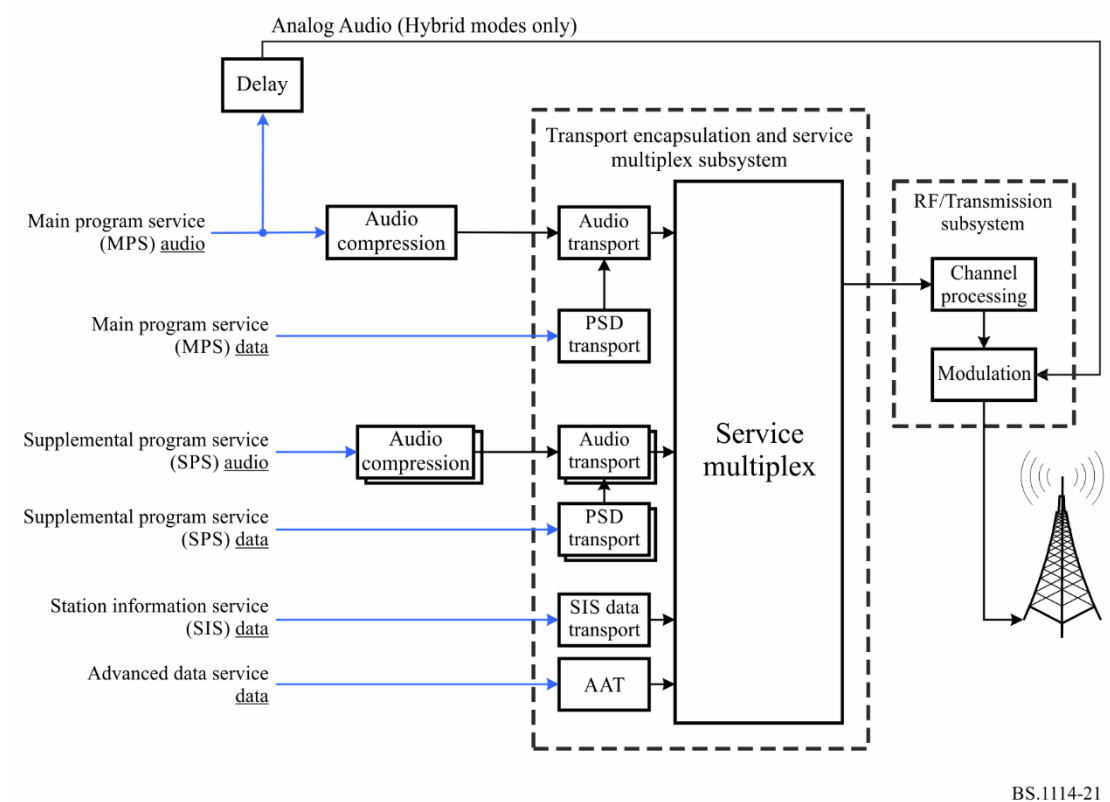

The IBOC implementation preserves the analogue broadcast located on the main frequency assignment. It retains the power of the analogue signal and adds low-level digital signal bands immediately adjacent to the analogue signal. These digital signals, immediately adjacent to the analogue, may be on either side of the analogue signal or on both sides. The power of each such digital signal may be individually adjusted, making possible controllable tradeoffs between coverage of the digital signal and co-existence with certain high density of pre-existing FM signals.

The operation of the digital signals may be associated with two modes: “Hybrid” and “All Digital”.

When the digital band, or multiple digital bands, are introduced and operated in the presence of the pre-existing and fully retained analogue signal, then the digital signal is perceived as the IBOC Hybrid configuration.

When the digital band, or multiple digital bands, are introduced but the existing analogue signal is terminated, then the digital signal is perceived as the IBOC All Digital configuration. No changes are required to the placement of the digital band or multiple digital bands.

Broadcasters may use the Hybrid mode during rollout of the technology to permit the continued operation of analogue-only receivers while new IBOC receivers deliver the new enhanced services as well as the existing analogue reception. At a future time, when the market is fully capable of receiving digital signals, broadcasters may switch to the All Digital mode

## 2 IBOC layers

The IBOC detailed performance specifications are organized in terms of the ISO OSI layered model. Each OSI layer of the broadcasting system, as shown in Fig. 22, has a corresponding layer, termed a peer, in the receiving system. The functionality of these layers is such that the combined result of lower layers is to effect a virtual communication between a given layer and its peer on the other side.

## 2.1 Layer 1

Layer 1 (L1) of Digital System C converts information and system control from Layer 2 (L2) into the IBOC waveform for transmission in the VHF band. The information and control is transported in discrete transfer frames via multiple logical channels through the L1 service access points (SAPs). These transfer frames are also referred to as L2 service data units (SDUs) and service control units (SCUs), respectively.

The L2 SDUs vary in size and format depending on the service mode. The service mode, a major component of system control, determines the transmission characteristics of each logical channel. After assessing the requirements of their candidate applications, higher protocol layers select service modes that most suitably configure the logical channels. The plurality of logical channels reflects the inherent flexibility of the system, which supports simultaneous delivery of various classes of digital audio and data.

L1 also receives system control as SCUs from L2. System control is processed in the system control processor.

FIGURE 22  
**IBOC FM System Protocol Stack block diagram**

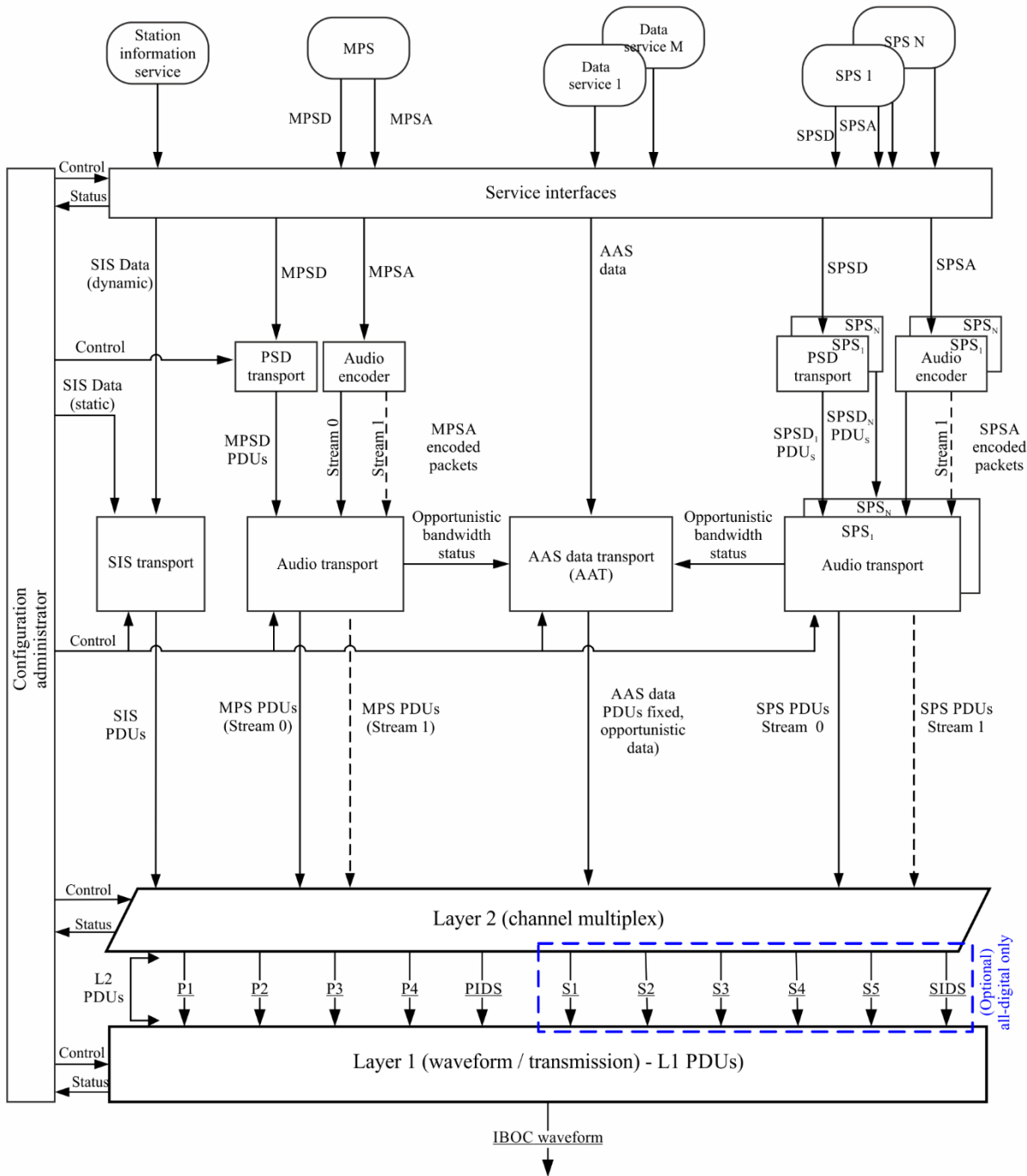

BS.1114-22

## 2.2 Waveforms and spectra

The design provides a flexible means of introducing to a digital broadcast system by providing two new waveform composition types: hybrid, and all digital. The hybrid composition can be further characterized by different bandwidth configurations termed main and extended. The various hybrid waveform composition types retain the analogue FM signal, while the all digital type does not. All digital waveforms operate well below allocated spectral emissions mask as currently defined by the Federal Communications Commission (FCC).

The digital signal is modulated using orthogonal frequency division multiplexing (OFDM). OFDM is inherently flexible, readily allowing the mapping of logical channels to different groups of subcarriers.

The OFDM symbol and fundamental IBOC system physical layer parameters are defined in Table 9.

TABLE 9  
IBOC System physical layer parameters

Parameter name	Symbol	Units	Exact value	Computed value (to 4 significant figures)
OFDM subcarrier spacing	$\Delta f$	Hz	1 488 375/4 096	363.4
Cyclic prefix width	$\alpha$	None	7/128	$5.469 \times 10^{-2}$
Cyclic prefix duration	$T_\alpha$	s	$(7/128) \cdot (4\,096/1\,488\,375)$	$1.586 \times 10^{-4}$
OFDM symbol duration	$T_s$	s	$(1 + \alpha) / \Delta f =$ $(135/128) \cdot (4\,096/1\,488\,375)$	$2.902 \times 10^{-3}$
OFDM symbol rate	$R_s$	Hz	$= 1/T_s$	344.5
L1 frame duration	$T_f$	s	$65\,536/44\,100 = 512 \cdot T_s$	1.486
L1 frame rate	$R_f$	Hz	$= 1/T_f$	$6.729 \times 10^{-1}$
L1 block duration	$T_b$	s	$= 32 \cdot T_s$	$9.288 \times 10^{-2}$
L1 block rate	$R_b$	Hz	$= 1/T_b$	10.77
L1 block pair duration	$T_p$	s	$= 64 \cdot T_s$	$1.858 \times 10^{-1}$
L1 block pair rate	$R_p$	Hz	$= 1/T_p$	5.383
Diversity delay frames	$N_{dd}$	None	= number of L1 frames of diversity delay	3
Number of subcarriers	$N/A$	None	70 kHz band: 191 100 kHz band: 267	
Used bandwidth	$PL/PU$	kHz	1488.375/4 096 · 191 1488.375/4 096 · 267	70 kHz band: 69.4 100 kHz band: 97.0

### 2.2.1 Main hybrid waveform

The digital signal is transmitted in a primary main (PM) sideband on either side of the existing analogue FM signal, and spans approximately 70 kHz. It may consist of only the primary lower (PL) signal or only the primary upper (PU) signal or both, as shown in Fig. 23. The power level of each sideband is adjusted individually. As currently employed in the USA, the total power level of that digital signal (in any chosen composition of two sidebands of equal or different power levels, or only one sideband) is limited to approximately 10 dB below the total power in the analogue FM signal. In the exemplary composition of two equal power sidebands, the power level of each sideband is approximately 13 dB below the total power in the analogue FM signal. The analogue signal may be monophonic or stereo, and may include subsidiary communications authorization (SCA) channels.

FIGURE 23

## IBOC FM System main hybrid waveform examples

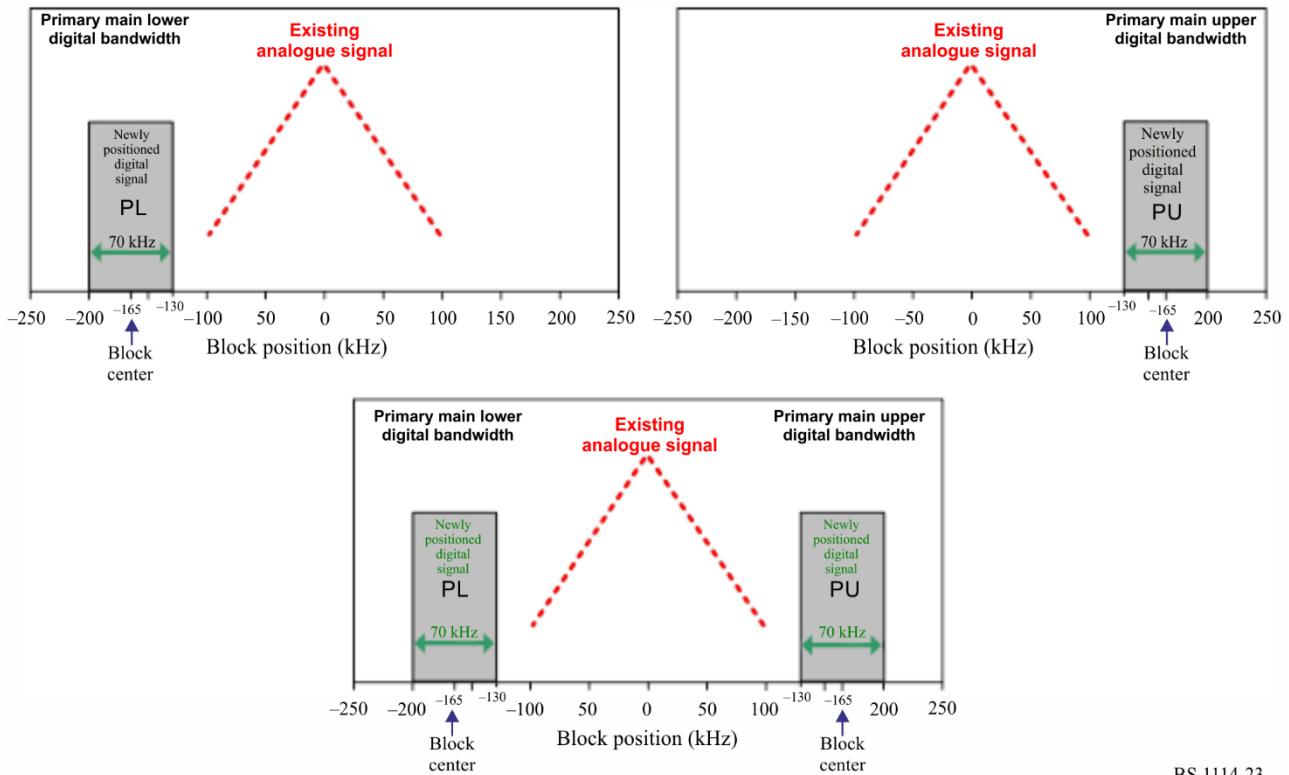

BS.1114-23

### 2.2.2 Extended hybrid waveform

In the extended hybrid waveform, the bandwidth of the hybrid sidebands can be extended toward the analogue FM signal, spanning up to approximately 100 kHz, in order to increase digital capacity. This additional spectrum, allocated to the inner edge of each primary main sideband, is termed the primary extended (PX) sideband. Examples for the expanded signal, including the main and the extended spectrum, are shown in Fig. 24. The power level of each sideband is adjusted individually. As currently employed in the USA, the total power level of that digital signal (in any chosen composition of two sidebands of equal or different power levels, or only one sideband) is limited to approximately 8.5 dB below the total power in the analogue FM signal. In the exemplary composition of two equal power sidebands, the power level of each sideband is approximately 11.5 dB below the total power in the analogue FM signal.



FIGURE 24

## IBOC FM System extended hybrid waveform examples

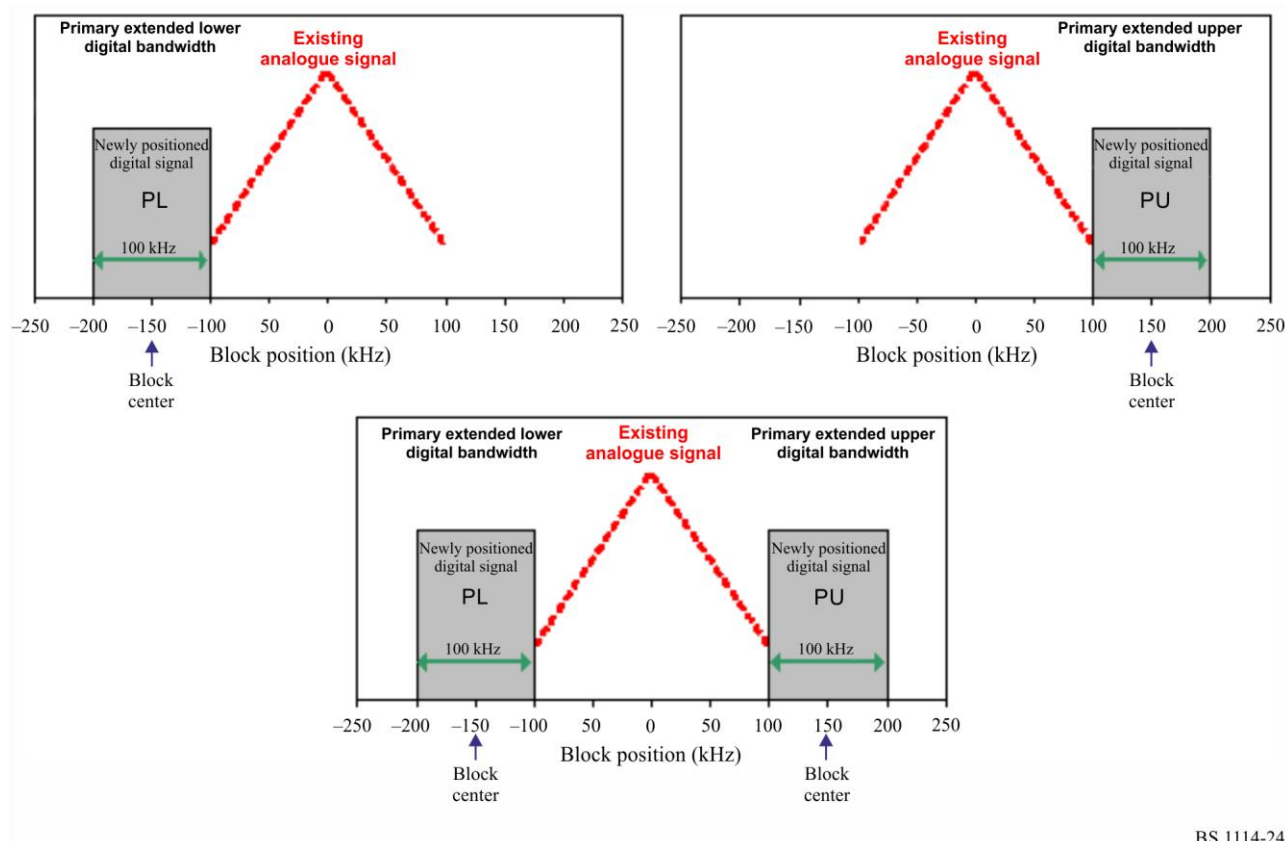

BS.1114-24

### 2.2.3 All digital waveform

The greatest system enhancements are realized with the all digital waveform, in which the analogue signal is removed and the bandwidth of the primary digital sidebands is fully extended as in the extended hybrid waveform. This is similar to the examples shown in Fig. 24, but without the now removed analogue FM signal. In addition, this waveform allows lower-power digital secondary sidebands to be transmitted in the spectrum vacated by the analogue FM signal.

## 2.3 System control channel

The system control channel (SCCH) transports control and status information. Primary and secondary service modes and diversity delay control are sent from L2 to L1, while synchronization information is sent from L1 to L2.

The service modes dictate all permissible configurations of the logical channels. The system allows for a total of sixty four service modes.

## 2.4 Logical channels

A logical channel is a signal path that conducts L2 SDUs in transfer frames into L1 with a specific grade of service, determined by the service mode. L1 of the Digital System C provides eleven logical channels to higher layer protocols. Not all logical channels are used in every service mode.

### 2.4.1 Primary logical channels

There are five primary logical channels which may be used with both the hybrid and all digital waveforms. They are denoted as P1, P2, P3, P4 and primary IBOC data service (PIDS). Table 10

shows the approximate theoretical information rate supported by each primary logical channel as a function of exemplary primary service mode.

TABLE 10

**Theoretical information rate examples of primary logical channels**

Service mode	Theoretical information rate (kbit/s)					Waveform
	P1	P2	P3	P4	PIDS	
MP1	98	0	0	0	1	Hybrid
MP2	98	0	12	0	1	Extended hybrid
MP3	98	0	25	0	1	Extended hybrid
MP11	98	0	25	25	1	Extended hybrid
MP12	98	0	0	0	1	Extended hybrid, all digital
MP5	25	74	25		1	Extended hybrid, all digital
MP6	49	49	0		1	Extended hybrid, all digital

### 2.4.2 Secondary logical channels

There are six secondary logical channels that are used only with the all digital waveform. They are denoted as S1, S2, S3, S4, S5, and secondary IBOC data service (SIDS). Table 11 shows the approximate theoretical information rate supported by each secondary logical channel as a function of secondary service mode.

TABLE 11

**Approximate theoretical information rate of secondary logical channels**

Service mode	Approximate information rate (kbit/s)						Waveform
	S1	S2	S3	S4	S5	SIDS	
MS1	0	0	0	98	6	1	All digital
MS2	25	74	25	0	6	1	All digital
MS3	49	49	0	0	6	1	All digital
MS4	25	98	25	0	6	1	All digital

### 2.4.3 Logical channel functionality

Logical channels P1 through P4 are designed to convey audio and data. S1 through S5 can be configured to carry data or audio. PIDS and SIDS logical channels are designed to carry IBOC data service (IDS) information.

The performance of each logical channel is completely described through three characterization parameters: transfer, latency, and robustness. Channel encoding, spectral mapping, interleaver depth, and diversity delay are the components of these characterization parameters. The service mode uniquely configures these components for each active logical channel, thereby allowing the assignment of appropriate characterization parameters.

In addition, the service mode specifies the framing and synchronization of the transfer frames through each active logical channel.

## **2.5 Layer 1 functional components**

Figure 25 describes a functional block diagram of L1 processing. Audio and data are passed from the higher OSI layers to the physical layer, the modem, through the L1 SAPs. Following the L1 processing diagram, a high-level description of each L1 functional block and the associated signal flow are provided.

### **2.5.1 Service access points**

The L1 SAPs define the interface between L2 and L1 of the system protocol stack. Each logical channel and the SCCH have their own SAP. Each channel enters L1 in discrete transfer frames, with unique size and rate determined by the service mode. These L2 transfer frames are typically referred to as L2 SDUs and SCUs.

### **2.5.2 Scrambling**

This function randomizes the digital data in each logical channel to “whiten” and mitigate signal periodicities when the waveform is demodulated in a conventional analogue FM demodulator.

### **2.5.3 Channel encoding**

IBOC Digital System uses convolutional codes with an effective coding rates as high as 4/5 and as low as 2/9. This convolutional encoding adds redundancy to the digital data in each logical channel to improve its reliability in the presence of channel impairments. The size of the logical channel vectors is increased in inverse proportion to the code rate. The encoding techniques are configurable by service mode. Diversity delay is also imposed on selected logical channels. At the output of the channel encoder, the logical channel vectors retain their identity.

### **2.5.4 Interleaving**

Interleaving in time and frequency is employed to mitigate the effects of burst errors. The interleaving techniques are tailored to the VHF fading environment and are configurable by service mode. Each logical channel is individually interleaved. The depth of the interleaver is based on the use of the channel. The length of the interleaver in the primary audio channels (P1 and P2) is equivalent to one L1 frame. In this process, the logical channels lose their identity. The interleaver output is structured in a matrix format; each matrix is comprised of one or more logical channels and is associated with a particular portion of the transmitted spectrum. Total diversity delay including interleaving is three L1 frames ( $3 \times 1.486$  s). The length of the interleaver in channels P3 and P4 is equivalent to two L1 frames. It is structured as contiguous mechanism with virtually no boundaries.

### **2.5.5 System control processing**

This function generates a matrix of system control data sequences which includes control configuration (such as service mode), for broadcast on the reference subcarriers. It also includes status for local use.

FIGURE 25  
FM air interface L1 functional block diagram

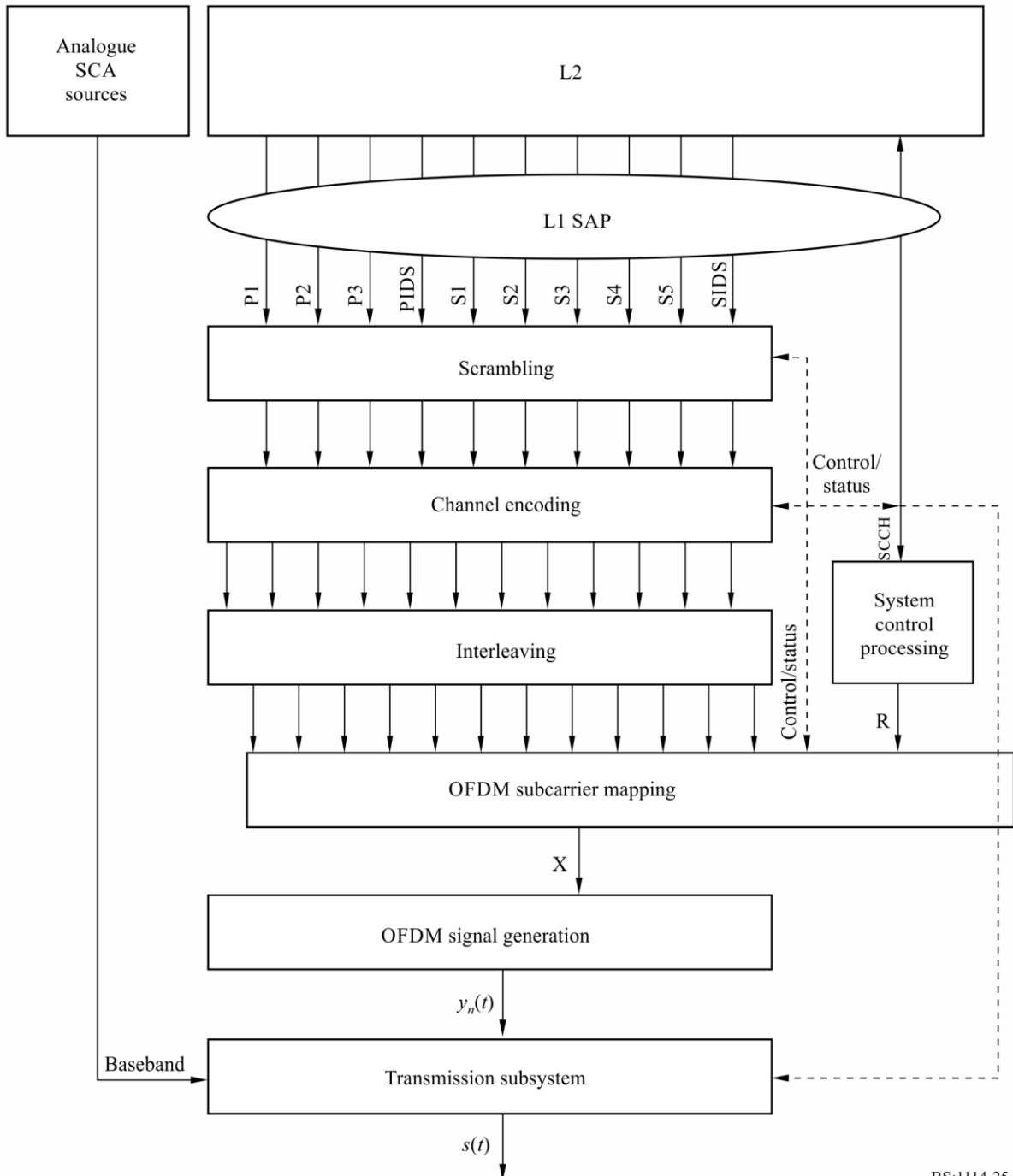

BS:1114-25

### 2.5.6 OFDM subcarrier mapping

This function assigns the interleaved matrices and the system control matrix to the OFDM subcarriers. One row of each active interleaver matrix is processed every OFDM symbol  $T_s$  to produce one output vector  $\mathbf{X}$ , which is a frequency-domain representation of the signal. The mapping is specifically tailored to the non-uniform interference environment and is a function of the service mode.

### 2.5.7 OFDM signal generation

This function generates the digital portion of the time-domain signal. The input vectors are transformed into a shaped time-domain baseband pulse,  $y_n(t)$ , defining one OFDM symbol.

### 2.5.8 Transmission subsystem

This function formats the baseband waveform for transmission through the VHF channel. Major sub-functions include symbol concatenation and frequency up-conversion. In addition, when transmitting the hybrid waveform, this function modulates the source, fully retains the analogue signal and combines it with the digital signal to form a composite hybrid signal,  $s(t)$ , ready for transmission.

## 3 Functional description

### 3.1 Introduction

OFDM signal generation receives complex, frequency-domain OFDM symbols from OFDM subcarrier mapping, and outputs time-domain pulses representing the digital portion of the Digital System C signal. A conceptual block diagram of OFDM signal generation is shown in Fig. 26.

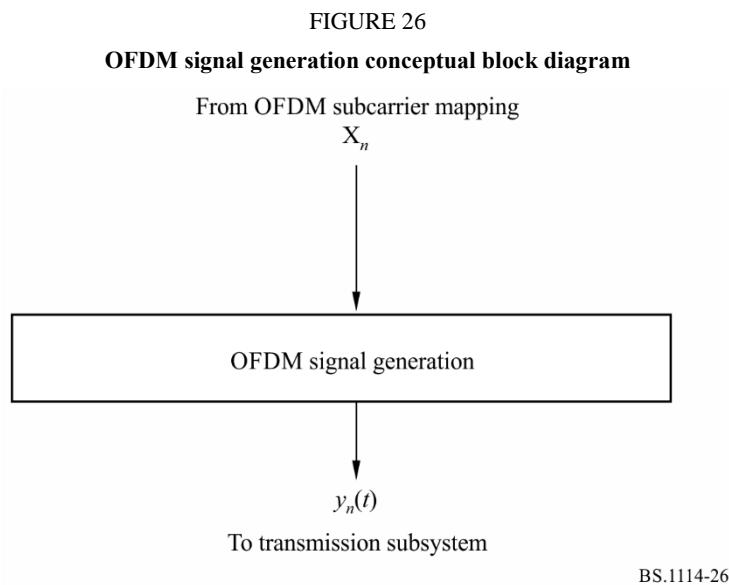

The input to OFDM signal generation is a complex vector  $\mathbf{X}_n$  of length  $L$ , representing the complex constellation values for each OFDM subcarrier in OFDM symbol  $n$ . The output of OFDM signal generation is a complex, baseband, time-domain waveform  $y_n(t)$ , representing the digital signal for OFDM symbol  $n$ .

### 3.2 Transmission subsystem

#### 3.2.1 Introduction

The transmission subsystem formats the baseband IBOC waveform for transmission through the VHF channel. Functions include symbol concatenation and frequency up-conversion. In addition, when transmitting the hybrid or extended hybrid waveforms, this function delays and modulates the baseband analogue signal before combining it with the digital waveform.

The input to this module is a complex, baseband, time-domain OFDM waveform,  $y_n(t)$ , from the OFDM signal generation function. A baseband analogue signal  $m(t)$  is also input from an analogue source, along with optional SCA signals, when transmitting the hybrid or extended hybrid waveform. In addition, analogue diversity delay (DD) control is input from L2 via the control channel. The output of this module is the IBOC waveform.

FIGURE 27

Hybrid/extended hybrid transmission subsystem functional block diagram

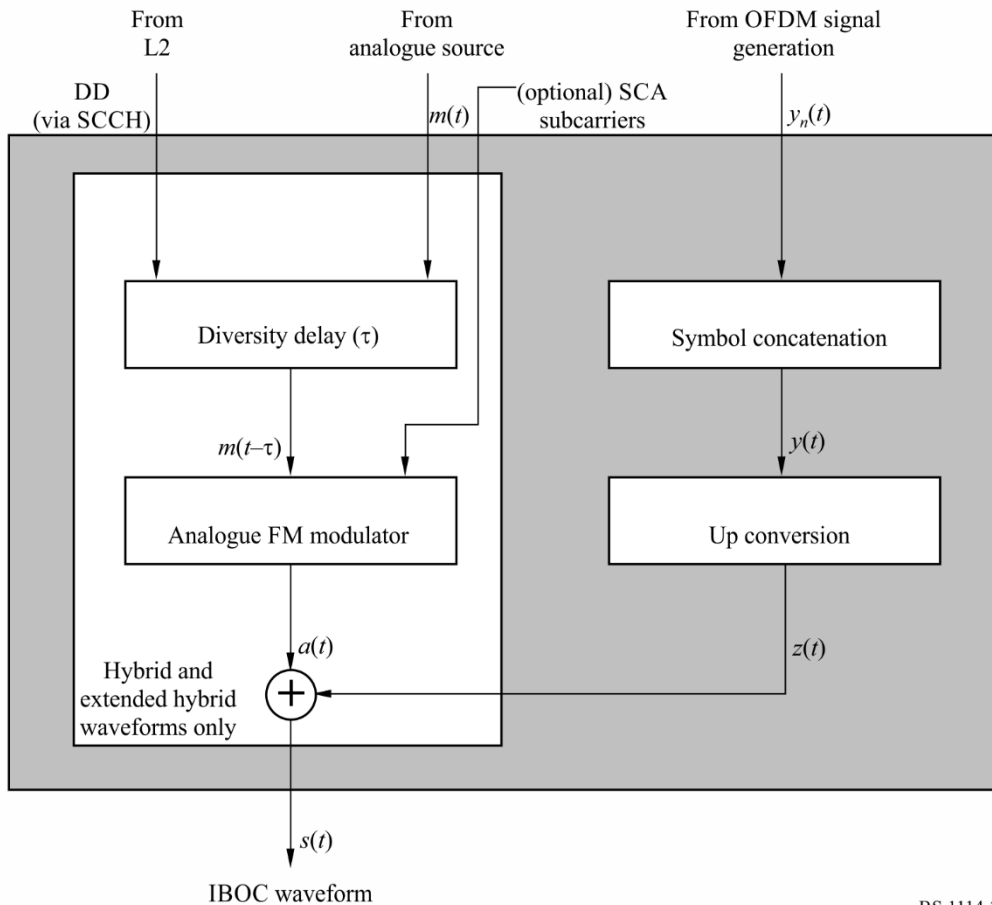

BS.1114-27

### 3.2.2 Diversity delay

When broadcasting the hybrid and extended hybrid waveforms, as shown in Fig. 27,  $z(t)$  is combined with the fully retained analogue FM signal  $a(t)$ . That digital signal  $z(t)$  already includes the analogue source audio  $m(t)$  in one of the provided audio services. The first step in generating  $a(t)$  is the application of DD to the baseband analogue signal  $m(t)$ . The analogue DD control bits received from L2 via the SCCH, are used by upper protocol layers to enable or disable the DD. When DD is enabled, an adjustable delay  $\tau$  is applied to the baseband analogue signal  $m(t)$ . The delay is set so that, at the output of the analogue/digital combiner,  $a(t)$  lags the corresponding digital signal  $z(t)$  by  $T_{dd}$ . Therefore, the Digital System audio programs include the same program as provided (with delay) by the analogue FM signal, thus allowing receivers for seamless transition between that audio being provided by the digital system to/from the same audio being provided by the analogue FM signal. The delay is adjustable to account for processing delays in the analogue FM and digital signal chains.

### 3.2.3 Analogue FM modulator

For the hybrid and extended hybrid waveforms, the appropriately delayed baseband analogue signal  $m(t-\tau)$  is frequency modulated to produce an RF analogue FM waveform identical to existing analogue signals.

### 3.2.4 Analogue/digital combiner

When broadcasting the hybrid or extended hybrid waveform, the analogue-modulated FM RF signal is combined with the digitally-modulated IBOC RF signal to produce the Digital System C signal,  $s(t)$ . Both the analogue and digital portions of the waveform are centred on the same carrier

frequency. The levels of each digital sideband in the output spectrum are appropriately scaled by OFDM subcarrier mapping.

### 3.2.5 All-digital signal

When broadcasting the all-digital waveform, the analogue processing chain, as shown in Fig. 27, including the FM signal  $a(t)$ , and the analogue/digital combiner, is not present. Then, the digital signal  $z(t)$  becomes the output signal  $s(t)$ .

### 3.3 Use of on channel repeaters

The use of OFDM modulation in Digital System C allows on-channel digital repeaters or a single frequency network to fill areas of desired coverage where signal losses due to terrain and/or shadowing are severe. A typical application would be where mountains or other terrain obstructions within the station's service areas limit analogue or digital performance.

Digital System C operates with an effective guard time between OFDM symbols of approximately  $150 \mu\text{s}^2$ . To avoid significant intersymbol interference the effective coverage in the direction of the primary transmission system should be limited to within 22 km. Specifically the ratio of the signal from the primary transmitter to the booster signal should be at least 10 dB at locations more than 22 km from the repeater in the direction of the primary antenna. Performance and distances between on-channel boosters can be improved through the use of directional antennas to protect the main station.

### 3.4 Global positioning system (GPS) synchronization

In order to ensure precise time synchronization, for rapid station acquisition and booster synchronization, each station is GPS locked. This is normally accomplished through synchronization with a signal synchronized in time and frequency to the GPS<sup>3</sup>. Transmissions that are not locked to GPS, would not be able to provide fast tuning at the receiver in the case of SFN since they cannot be synchronized with other stations<sup>4</sup>.

## 4 Digital sideband levels

An example for the amplitude scaling of each OFDM subcarrier within each digital sideband vs. the desired power spectral density is noted in Table 12 for the hybrid, extended hybrid and all digital waveforms. The power spectral density values for the hybrid waveforms are specified relative to the total power of the unmodulated analogue FM carrier (assumed equal to 1). The power spectral density values for the all digital waveform are specified relative to the total power of the unmodulated analogue FM carrier (assumed equal to 1) that would have been transmitted in the hybrid and extended hybrid modes.

---

<sup>2</sup>  $150 \mu\text{s}$  equates to a 45 km propagation distance.

<sup>3</sup> GPS locked stations are referred to as Level I: GPS-locked transmission facilities.

<sup>4</sup> Level II: non-GPS locked transmission facilities.

TABLE 12

## OFDM subcarrier scaling vs. power spectral density examples

Waveform	Mode	Sidebands	Amplitude scale factor notation	Amplitude scale factor (relative to total analogue FM power) per subcarrier	Power spectral density <sup>(1)</sup> in a 1 kHz bandwidth (dBc)
Hybrid	MP1	Primary	$a_{0L}/a_{0U}$	$5.123 \times 10^{-3}$	-41.39
Extended hybrid	MP2, MP3, MP11, MP12, MP5, MP6	Primary	$a_{0L}/a_{0U}$	$5.123 \times 10^{-3}$	-41.39
All digital	MP5, MP6, MP12	Primary	$a_2$	$1.67 \times 10^{-2}$	-31.39
		Secondary	$a_4$	$5.123 \times 10^{-3}$	-41.39
	MS1-MS4	Secondary	$a_5$	$3.627 \times 10^{-3}$	-44.39
		Secondary	$a_6$	$2.567 \times 10^{-3}$	-47.39
		Secondary	$a_7$	$1.181 \times 10^{-3}$	-50.39

<sup>(1)</sup> Power spectral density relative to the total analogue FM power of the present or vacant analogue FM signal.

For the hybrid and extended hybrid waveforms, the values noted in the examples in Table 12 were chosen so that the total average power in a primary digital sideband (upper or lower) is 23 dB to 21.5 dB (mode dependent) below the total power of unmodulated analogue FM carrier.

For the all digital waveform, the values noted in the examples in Table 12 were chosen so that the total average power in a primary digital sideband (upper or lower) is at least 10 dB above the total power in the hybrid primary digital sidebands. In addition, the values were chosen so that the total average power in the secondary digital sidebands (upper and lower) is at least 10 dB below the total power in the all digital primary digital sidebands.

TABLE 13

## Digital sideband power vs. total digital power examples

Total digital-to-analogue power ratio (dBc)				Digital sideband-to-analogue power ratio (dBc)							
MP1	MP3	MP11	MP12	MP1		MP3		MP11		MP12	
				L	U	L	U	L	U	L	U
-20.0	-19.2	-18.5	-	-23.0	-23.0	-22.2	-22.2	-21.5	-21.5	-	-
-14.0	-13.2	-12.5	-	-17.0	-17.0	-16.2	-16.2	-15.5	-15.5	-	-
-10.0	-9.2	-8.5	-	-13.0	-13.0	-12.2	-12.2	-11.5	-11.5	-	-
-10.0	-9.2	-8.5	-	-11.4	-15.4	-10.6	-14.6	-9.9	-13.9	-	-
-	-	-	-14	-	-	-	-	-	-	-14	-
-	-	-	-8.5	-	-	-	-	-	-	-	-8.5

The configuration examples in Table 13 demonstrate the flexibility in choosing the bandwidth and power for the desired operation. The system can be configured to satisfy the throughput and



robustness requirements along with the co-existence realities. That may be achieved by employing different bandwidth configurations, employing one or two sidebands, choosing the total digital signal power and individually setting the power level of each side band.

### 5 Spectrum for hybrid mode

The digital signal is transmitted in Primary Main sidebands on either side of the analogue FM signal. Each Primary Main sideband is comprised of ten frequency partitions, which are allocated among subcarriers 356 through 545, or -356 through -545 (see Fig. 28 and Table 14). Subcarriers 546 and -546, also included in the PM sidebands, are additional reference subcarriers. The amplitude of the subcarrier within a PM sideband is uniformly scaled by an amplitude scale factor.

FIGURE 28  
Spectrum of the hybrid waveform – Service mode MP1

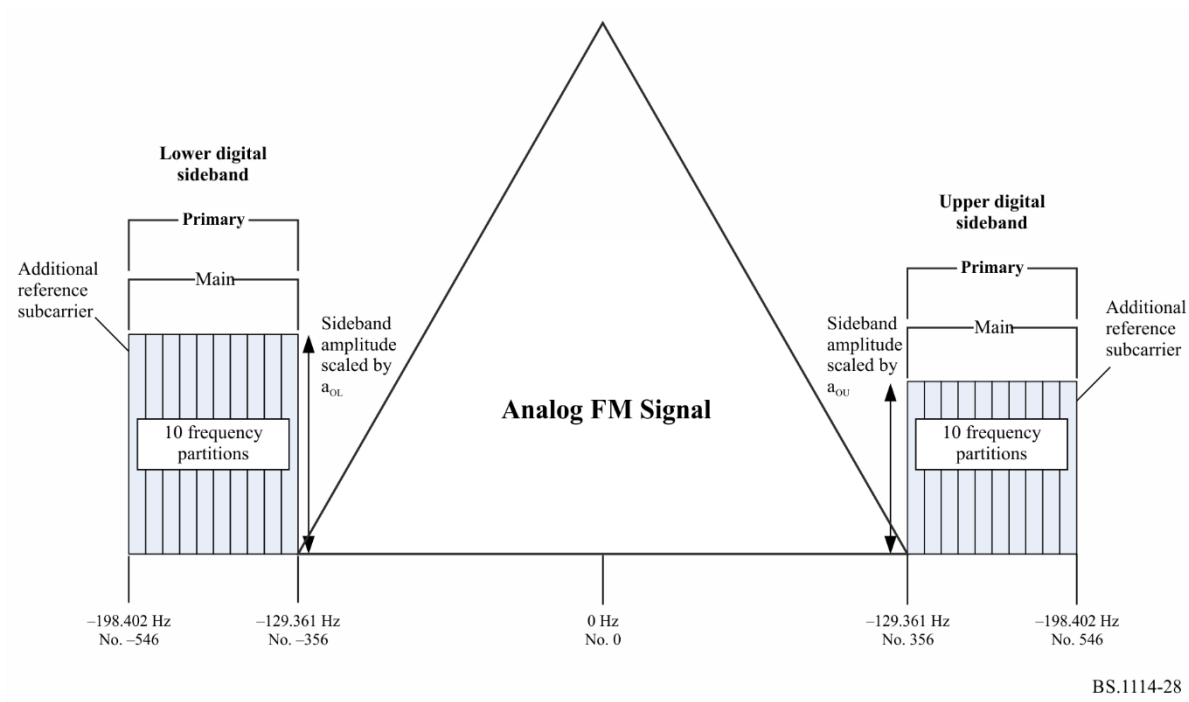

TABLE 14

## Hybrid waveform spectral summary – service mode MP1

Sideband	Number of frequency partitions	Frequency partition ordering	Subcarrier range	Subcarrier frequencies (from channel centre) (Hz)	Amplitude scale factor	Frequency span (Hz)	Comments
Upper PM	10	A	356 to 546	129 361 to 198 402	$a_{0U}$	69 041	Includes additional reference subcarrier 546
Lower PM	10	B	-356 to -546	-129 361 to -198 402	$a_{0L}$	69 041	Includes additional reference subcarrier -546

## 6 Spectrum for extended hybrid mode

The extended hybrid waveform is created by adding primary extended sidebands to the PM sidebands present in the hybrid waveform. Depending on the service mode, one, two, or four frequency partitions can be added to the inner edge of each PM sideband. Each PM sideband consists of ten frequency partitions and an additional reference subcarrier spanning subcarriers 356 through 546, or -356 through -546. The upper primary extended sidebands include subcarriers 337 through 355 (one frequency partition), 318 through 355 (two frequency partitions) or 280 through 355 (four frequency partitions). The lower primary extended sidebands include subcarriers -337 through -355 (one frequency partition), -318 through -355 (two frequency partitions) or -280 through -355 (four frequency partitions). The subcarriers within a primary extended sideband are uniformly scaled the same amplitude scale factor,  $a_{0L}$  or  $a_{0U}$ , as the PM sideband (see Fig. 29 and Table 15).

FIGURE 29

Spectrum of the extended hybrid waveform – Service modes MP2, MP3, MP11, MP12, MP5 and MP6

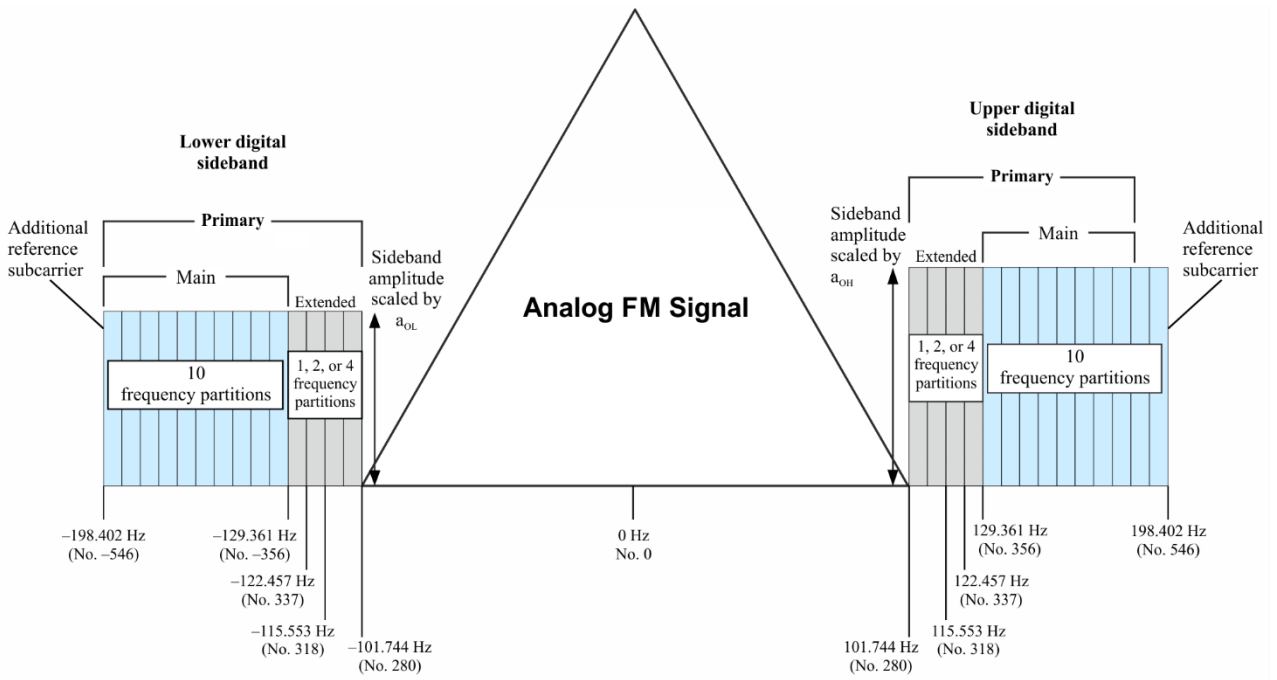

TABLE 15

**Extended hybrid waveform spectral summary – service modes MP2, MP3,  
MP11, MP12, MP5 and MP6**

Sideband	Number of frequency partitions	Frequency partition ordering	Subcarrier range	Subcarrier frequencies (from channel centre) (Hz)	Amplitude scale factor	Frequency span (Hz)	Comments
Upper PM	10	A	356 to 546	129 361 to 198 402	$a_{0U}$	69 041	Includes additional reference subcarrier 546
Lower PM	10	B	-356 to -546	-129 361 to -198 402	$a_{0L}$	69 041	Includes additional reference subcarrier -546
Upper primary extended (1 frequency partition)	1	A	337 to 355	122 457 to 128 997	$a_{0U}$	6 540	None
Lower primary extended (1 frequency partition)	1	B	-337 to -355	-122 457 to -128 997	$a_{0L}$	6 540	None
Upper primary extended (2 frequency partitions)	2	A	318 to 355	115 553 to 128 997	$a_{0U}$	13 444	None
Lower primary extended (2 frequency partitions)	2	B	-318 to -355	-115 553 to -128 997	$a_{0L}$	13 444	None
Upper primary extended (4 frequency partitions)	4	A	280 to 355	101 744 to 128 997	$a_{0U}$	27 253	None
Lower primary extended (4 frequency partitions)	4	B	-280 to -355	-101 744 to -128 997	$a_{0L}$	27 253	None

## 7 Spectrum for all digital mode

The all digital waveform is constructed by removing the analogue signal, fully expanding the bandwidth of the primary digital sidebands and adding lower-power secondary sidebands in the spectrum vacated by the analogue signal. The spectrum of the all digital waveform is shown in Fig. 30.

FIGURE 30

Spectrum of the all digital waveform – Service modes MP5, MP6 and MP12, MS1 through MS4

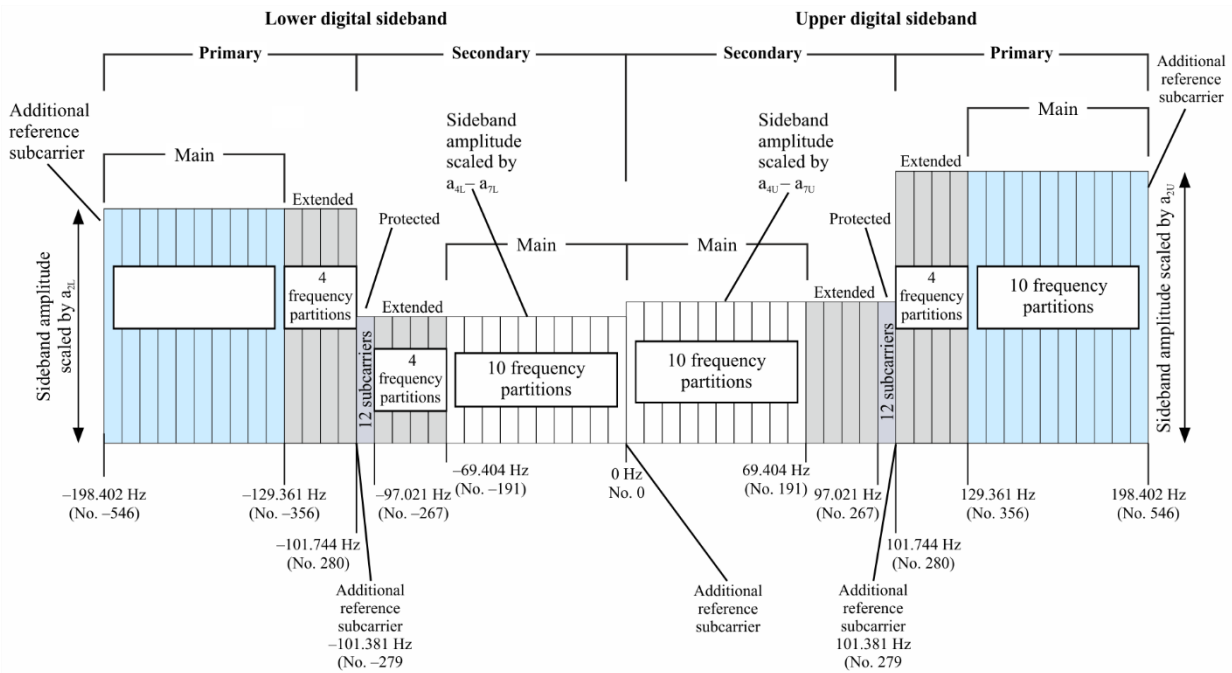

BS.1114-30

In addition to the ten main frequency partitions, all four extended frequency partitions are present in each employed primary sideband of the all digital waveform. Each employed secondary sideband also has ten secondary main (SM) and four secondary extended frequency partitions. Unlike the primary sidebands, however, the SM frequency partitions are mapped nearer to channel centre with the extended frequency partitions farther from the centre.

Each secondary sideband also supports a small secondary protected (SP) region consisting of 12 OFDM subcarriers and reference subcarriers 279 and -279. These sidebands are referred to as “protected” because they are located in the area of spectrum least likely to be affected by analogue or digital interference. An additional reference subcarrier is placed at the centre of the channel (0). Frequency partition ordering of the SP region does not apply since the SP region does not contain frequency partitions

Each SM sideband spans subcarriers 1 through 190 or -1 through -190. The upper secondary extended sideband includes subcarriers 191 through 266 and the upper SP sideband includes subcarriers 267 through 278, plus additional reference subcarrier 279. The lower secondary extended sideband includes subcarriers -191 through -266 and the lower SP sideband includes subcarriers -267 through -278, plus additional reference subcarrier -279. The total frequency span of the entire all digital spectrum is up to 396 803 Hz. The subcarriers within the PM and primary extended sidebands are scaled by an amplitude scale factor,  $a_{2L}$  or  $a_{2U}$ . The subcarriers within the SM, secondary extended and SP sidebands are uniformly scaled by an amplitude scale factor having four discrete levels  $a_{4L}$ - $a_{7L}$  or  $a_{4U}$ - $a_{7U}$  (see Fig. 30 and Table 16).

TABLE 16

**All digital waveform spectral summary – service modes MP5, MP6 and MP12, MS1 through MS4**

Sideband	Number of frequency partitions	Frequency partition ordering	Sub-carrier range	Sub-carrier frequencies (from channel centre) (Hz)	Amplitude scale factor	Frequency span (Hz)	Comments
Upper PM	10	A	356 to 546	129 361 to 198 402	$a_{2Y}$	69 041	Includes additional reference subcarrier 546
Lower PM	10	B	-356 to -546	-129 361 to -198 402	$a_{2L}$	69 041	Includes additional reference subcarrier -546
Upper primary extended	4	A	280 to 355	101 744 to 128 997	$a_{2U}$	27 253	None
Lower primary extended	4	B	-280 to -355	-101 744 to -128 997	$a_{2L}$	27 253	None
Upper SM	10	B	0 to 190	0 to 69 041	$a_{4U-a7U}$	69 041	Includes additional reference subcarrier 0
Lower SM	10	A	-1 to -190	-363 to -69 041	$a_{4L-a7L}$	68 678	None
Upper secondary extended	4	B	191 to 266	69 404 to 96 657	$a_{4U-a7U}$	27 253	None
Lower secondary extended	4	A	-191 to -266	-69 404 to -96 657	$a_{4L-a7L}$	27 253	None
Upper SP	Not applicable	Not applicable	267 to 279	97 021 to 101 381	$a_{4U-a7U}$	4 360	Includes additional reference subcarrier 279
Lower SP	Not applicable	Not applicable	-267 to -279	-97 021 to -101 381	$a_{4L-a7L}$	4 360	Includes additional reference subcarrier 279

## 8 Emission limitations

The adjustable sideband power level along with the digital subcarriers spectral shaping allow for fine tuning of the power spectrum density for the operating environment. It may be configured for adequately matching the emission limits which govern the operating location, special co-existence conditions, operating mode and the capabilities of specifically employed broadcasting equipment. Exemplary configurations for matching such different operation environments are provided.

### 8.1 Emission limits for IBOC operation with region II practiced analogue mask

Hybrid and all digital subcarriers power levels are operated well below the FM emissions masks. An example of one administration’s mask, from the United States of America, Code of Federal Regulations (CFR), Title 47 § 73.317 is summarized in Table 17.

TABLE 17  
Emission limits as a function of off-set from carrier frequency for FM channels in the United States of America

Offset from carrier frequency (kHz)	Power spectral density relative to unmodulated analogue FM carrier (dBc/kHz) <sup>(1)</sup>
120 to 240	-25
240 to 600	-35
Greater than 600	-80, or $-43 - 10 \log_{10} x$ , whichever is less, where $x$ is power (W) refers to the total unmodulated transmitter output carrier power

<sup>(1)</sup> Measurements are made by averaging the power spectral density in a 1 kHz bandwidth over a 10 s segment of time.

Figure 31 depicts the hybrid and extended hybrid waveform emission limits from all sources in dB relative to the power of the unmodulated analogue carrier, measured in a 1 kHz bandwidth. The emission limits composition results from jointly applying the individual emission limits for each digital sideband. This emission measurement is inclusive of all sources including:

- phase noise of the IBOC exciter and
- intermodulation products from the transmitter. In Tables 17, 18, 19 and 20 the levels have been adjusted to depict the level below the 0 dBc emissions mask.

TABLE 18  
IBOC digital carrier power limits<sup>(1)</sup>

Hybrid mode	All-digital mode	
	Main programme carriers	Secondary auxiliary service carriers
-31.39	-31.39	-36.39

<sup>(1)</sup> Nominal power spectral density in a 1 kHz bandwidth to the reference 0 dBc CFR mask.

#### 8.1.1 Emission limits for hybrid mode operation

Noise from all sources, excluding frequencies removed from the carrier between 100 to 200 kHz, including phase noise of the IBOC exciter and intermodulation products, conforms to the limits of Fig. 31 and Table 19. Requirements are summarized as follows, where dBc is relative to the exemplary analogue FM mask, as indicated in Table 17, in a 1 kHz bandwidth of the digital sidebands.

NOTE – The actual upper and lower sidebands may differ in power level. In certain configurations only one sideband may be employed.

FIGURE 31

IBOC hybrid mode emission limits\*

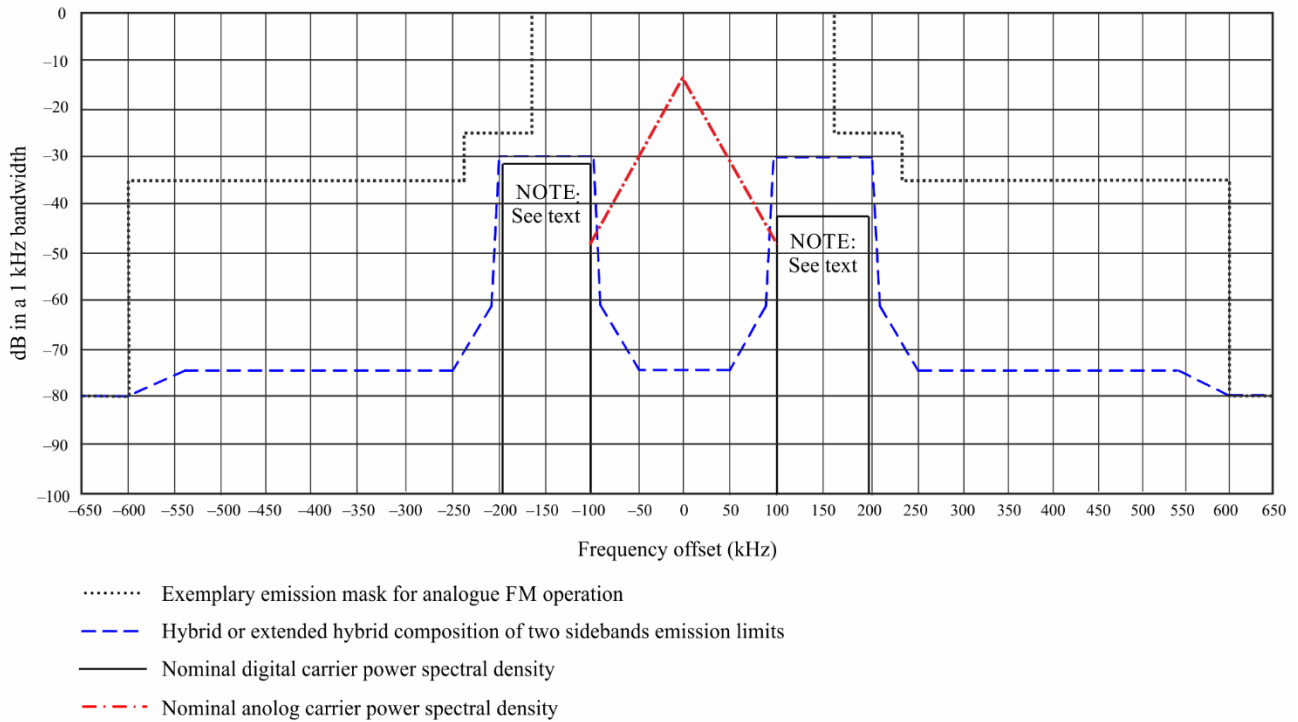

BS.1114-31

TABLE 19

Hybrid mode emission limits

Frequency offset relative to carrier (kHz)	Level (dBc/kHz)
0-50	-74.39
92.5	-61.39
100-200	-30
207.5	-61.39
250	-74.39
>600	-80

**8.1.2 Emission limits for all-digital mode operation**

Noise from all sources, for frequencies removed from the carrier by more than 200 kHz, including phase noise of the IBOC exciter and intermodulation products, shall conform to the limits of Fig. 32 and Table 20. In all-digital modes the previously present (and now removed) analogue FM signal may be replaced by additional (secondary) sidebands. However, the analogue FM mask is still considered when configuring the sideband power levels. Requirements are summarized as follows, where dBc is relative to the exemplary analogue FM mask, as indicated in Table 17, in a 1 kHz bandwidth of the digital sidebands.

NOTE – The actual upper and lower sidebands may differ in power level. In certain configurations only one sideband may be employed.



FIGURE 32  
All-digital emission limits\*

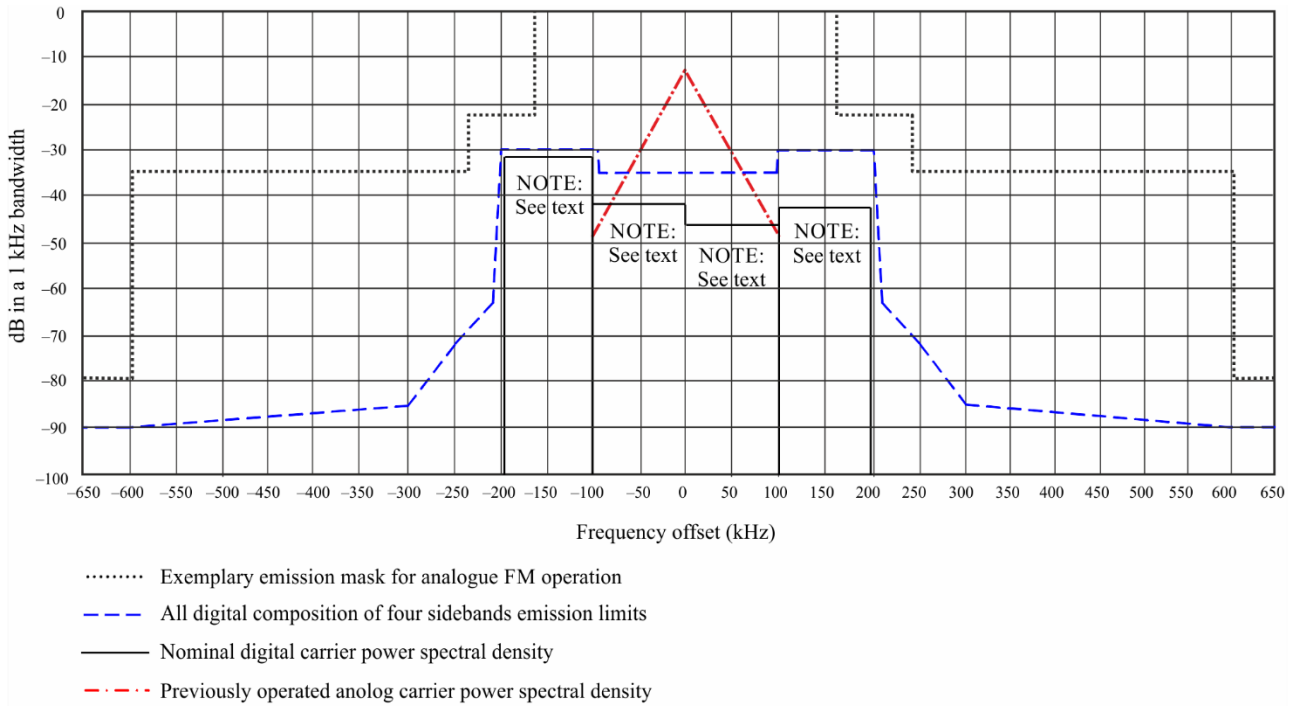

BS.1114-32

Requirements are summarized as follows, where dBc is relative to the exemplary analogue FM mask, as indicated in Table 17, in a 1 kHz bandwidth of the digital sidebands.

TABLE 20

All-digital emission limits

Frequency offset relative to carrier (kHz)	Level (dBc/kHz)
0-100	-35
100-200	-30
207.5	-63
250	-72
300	-85
>600	-90

## 8.2 Emission limits for IBOC operation with region I practiced analogue mask

An example of one administration’s mask as practiced in Europe, is provided in ETSI EN 302 018-1. The adjustable IBOC digital subcarriers spectral shaping is configured for satisfying the emission limits requirements, and the digital sideband complies with the mask. Such exemplary configurations of the IBOC sideband emission limits are described in Fig. 33 in respect to the administration’s analogue FM emission mask. The emission limits details are provided in Tables 21 and 22, where dBc is relative to the exemplary analogue FM mask.

FIGURE 33

IBOC sideband emission limits\*

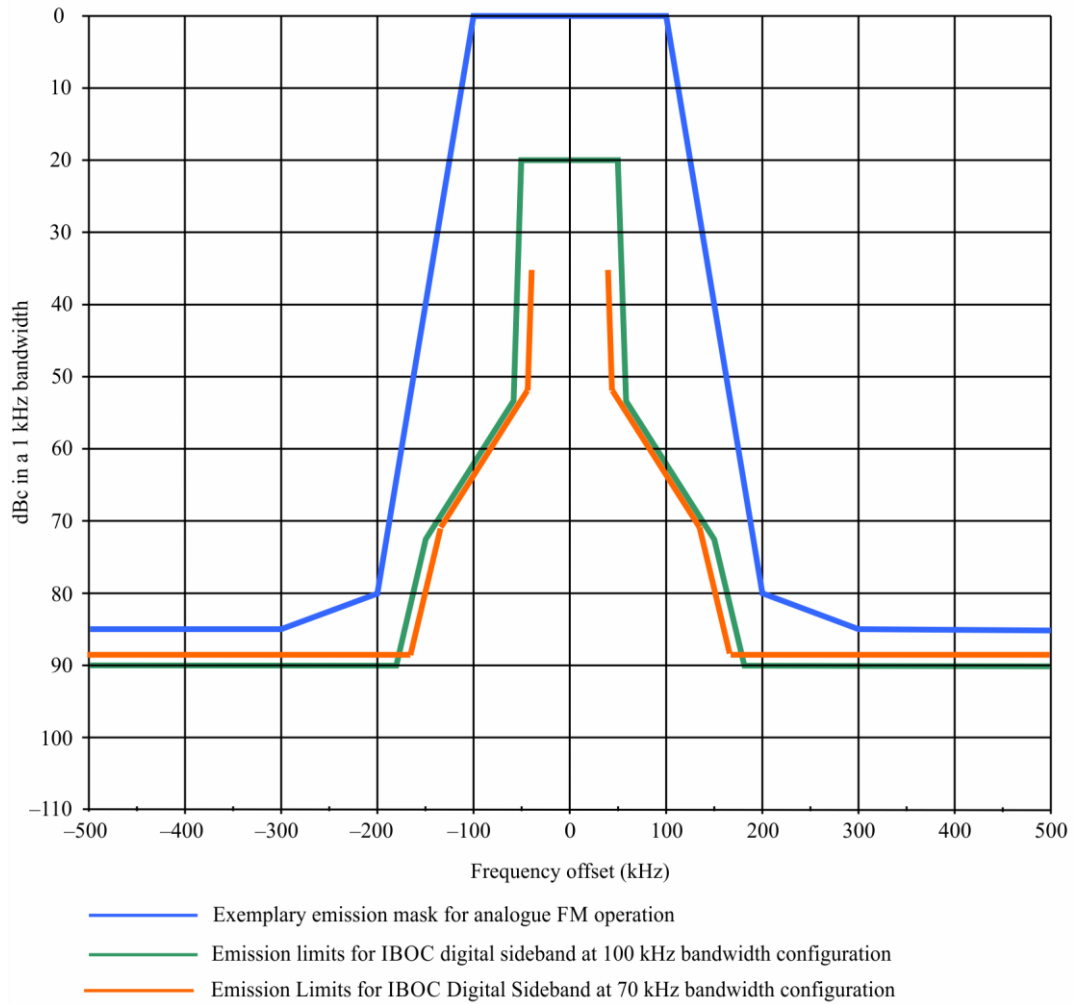

BS.1114-33

TABLE 21

IBOC sideband emission limits for 100 kHz sideband bandwidth modes

Frequency offset relative to carrier (kHz)	Level (dBc/kHz)
50 kHz	-20
57.5 kHz	-53
100 kHz	-62
150 kHz	-72.5
181 kHz	-90
500 kHz	-90

TABLE 22

## IBOC sideband emission limits for 70 kHz sideband bandwidth modes

Frequency offset relative to carrier (kHz)	Level (dBc/kHz)
35 kHz	-18.5
42.5 kHz	-51.5
100 kHz	-62
135 kHz	-71
166 kHz	-88.5
500 kHz	-88.5

## 9 Summary of laboratory test results

Laboratory tests of Digital System C are summarized below. The fading profiles used are denoted by urban fast (UF), urban slow (US), rural fast (RF), or terrain-obstructed (TO) fast and were independently applied to the desired signal and each of the interferers. The interference level is given in units of dB<sub>des</sub>, which is defined as dB relative to the total power of the desired hybrid signal. For each block error rate test, Table 23 lists the interference scenario under which it was run, the  $C_d/N_0$  (dB/Hz), the fading profile, the level of the interference and the measured block error rate.

TABLE 23

## FM hybrid IBOC DSB performance test results

Tests	Input parameters					Measurements		
						Digital performance	Analogue subjective evaluation at digital ToA	
	$C_d/N_0$ (dB/Hz)	Fading	Co-Channel (dB <sub>des</sub> )	1 <sup>st</sup> adjacent (dB <sub>des</sub> )	2 <sup>nd</sup> adjacent (dB <sub>des</sub> )	Block error rate	File	Subjective audio degradation
Gaussian noise no fading/ no interference	54.1					0.16	audio1.wav	Audible
	54.5					0.032		
	55.1					0.0029		
9-ray fading	55.4	UF				0.8	audio2.wav	Audible
	56.4					0.056		
	57.3					0.012		
	59.3	US				0.106	audio3.wav	Audible
	60.4					0.054		
	61.4					0.0202		
	55.9	RF				0.6	audio4.wav	Audible
	56.8					0.087		
	57.8					0.007		
	55.9	TO				0.317	audio5.wav	Audible
	56.9					0.026		
	57.8					0.001		

TABLE 23 (end)

Tests	Input parameters					Measurements		
						Digital performance	Analogue subjective evaluation at digital ToA	
	$C_d/N_0$ (dB/Hz)	Fading	Co-Channel (dB <sub>des</sub> )	1 <sup>st</sup> adjacent (dB <sub>des</sub> )	2 <sup>nd</sup> adjacent (dB <sub>des</sub> )	Block error rate	File	Subjective audio degradation
1 <sup>st</sup> adjacent interference	61.5	UF		-6.0		0.075	audio6.wav	Audible
	62.4					0.045		
	63.4					0.00842		
	59.4	UF		-18.0		0.077	audio7.wav	Audible
	60.3					0.012		
	61.3					0.006		
	58.2	UF		-24.0		0.0735	audio8.wav	Audible
	59.2					0.0109		
	60.1					0.005		
	57.2	UF		-30.0		0.0287	audio9.wav	Audible
58.2	0.0082							
2 <sup>nd</sup> adjacent interference	57.9	UF			20.0	0.1	audio10.wav	Audible
	58.9					0.018		
	60.5					0.00085		
Co-channel interference	60.2	UF	-10.0			0.013	audio11.wav	Beyond point of failure
	61.3					0.0097		
	65.3					0.00014		
	58.4	UF	-20.0			0.013	audio12.wav	Audible
	59.3					0.0011		
	60.4					0.00035		

### 9.1 Performance in Gaussian noise

This test measured an upper bound to system performance and recorded analogue audio at the digital threshold of audibility (ToA) in the presence of Gaussian noise, in the absence of Rayleigh fading and interference. Performance is shown in the block error rate curves of Fig. 34, and summarized in Table 23. Table 23 indicates that just prior to digital ToA, analogue audio quality is audibly degraded.

FIGURE 34  
 Block error rate results of the hybrid system in different types of 9-ray fading and additive white Gaussian noise (AWGN)

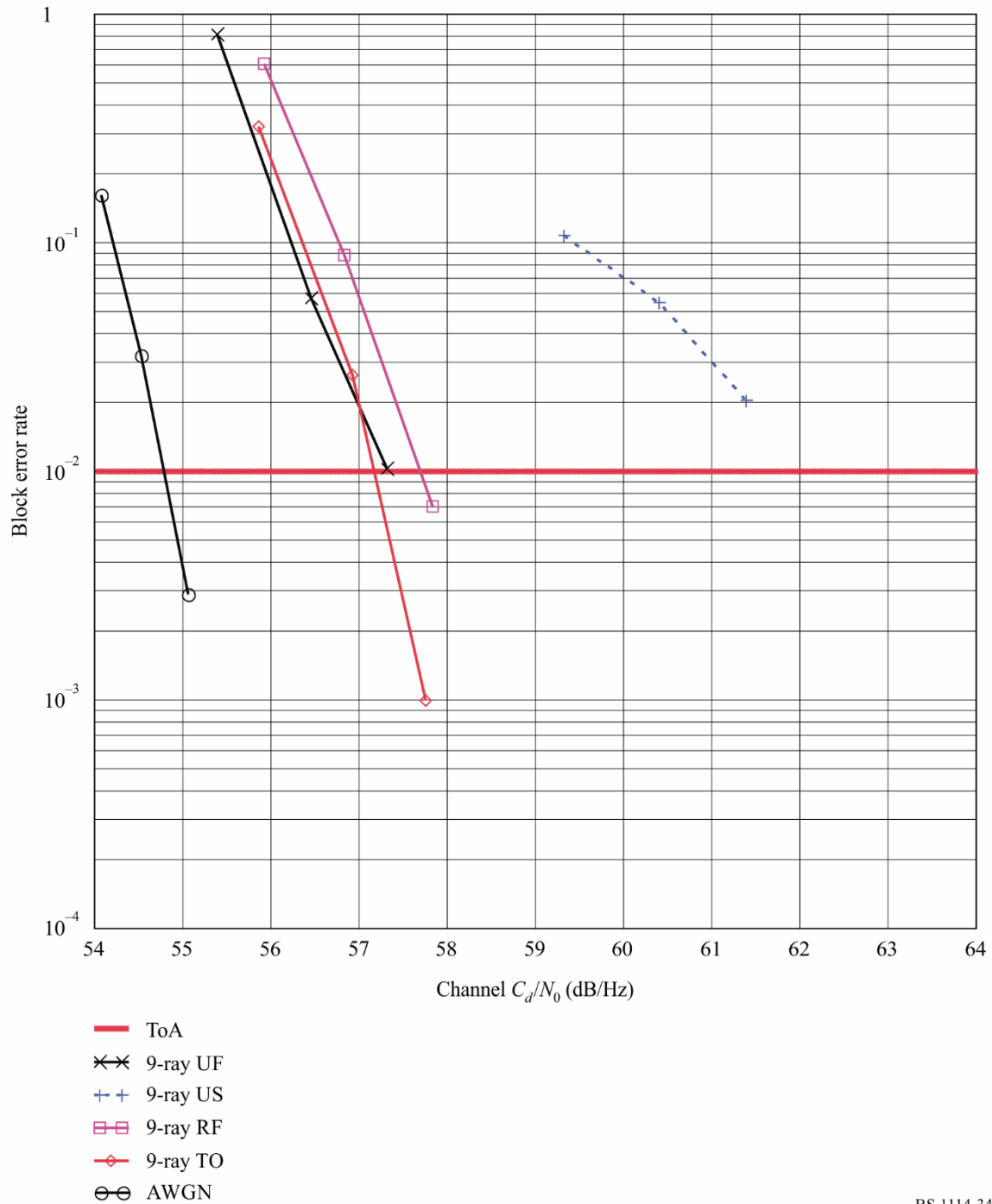

BS.1114-34

### 9.2 Performance in Rayleigh fading

This test measured system performance and recorded analogue audio at the digital ToA in Gaussian noise and in various types of Rayleigh fading. Performance is shown in the block error rate curves of Fig. 35 and summarized in Table 23. Results indicate an insensitivity to fading profile, except in the case of urban slow fading, which produces signal fades of very long duration. The urban slow fading profile produces particularly annoying outages in existing analogue transmissions.

FIGURE 35

Block error rate results of a hybrid system in 9-ray UF fading with an independently faded first-adjacent interferer

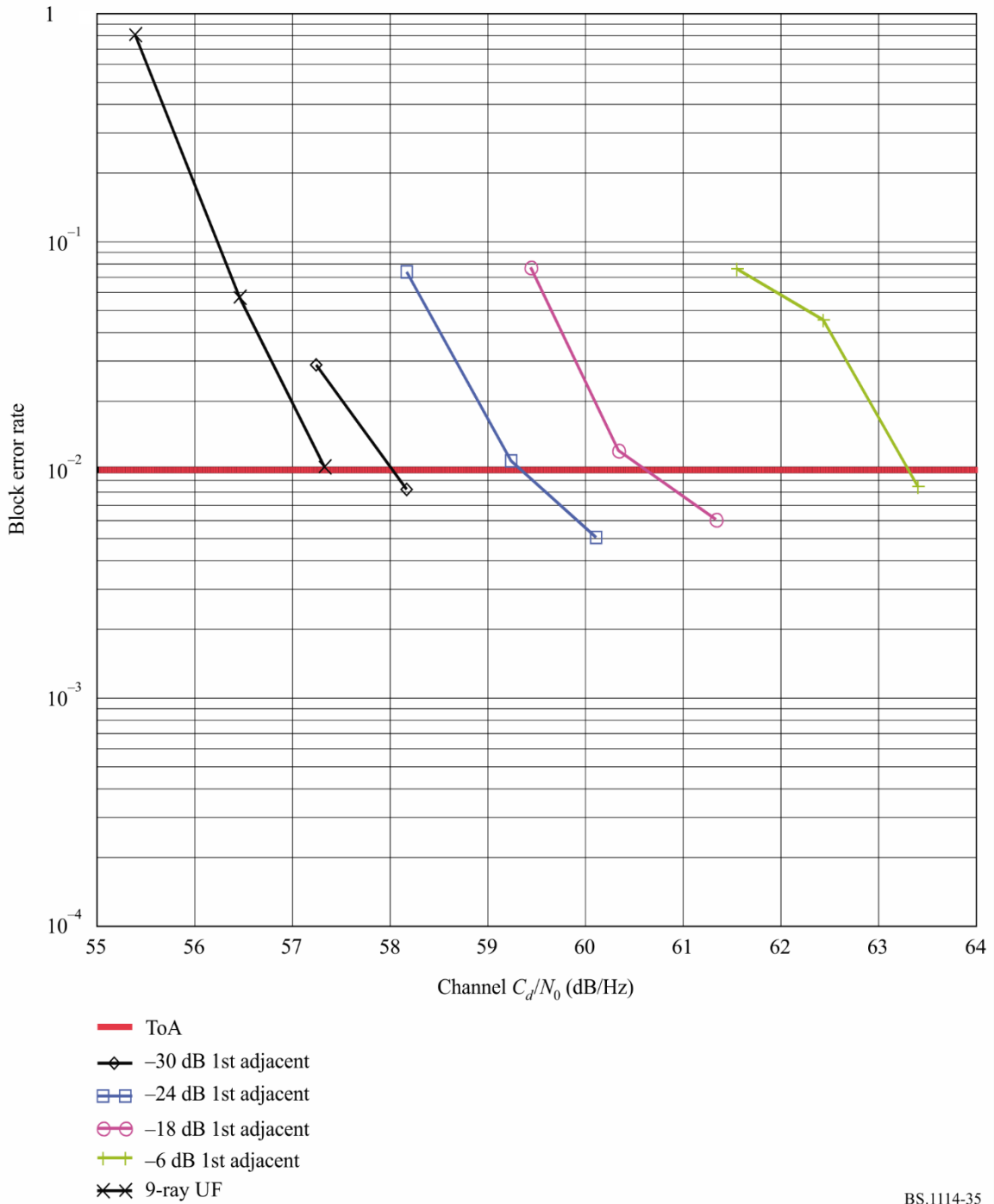

BS.1114-35

**9.2.1 Urban fast (UF)**

Table 23 gives the subjective analogue audio evaluation which indicates that, just prior to digital ToA, analogue audio quality is audibly degraded.

**9.2.2 Urban slow (US)**

Table 23 gives the subjective analogue audio evaluation which indicates that, just prior to digital ToA, analogue audio quality is audibly degraded.

### 9.2.3 Rural fast (RF)

Table 23 gives the subjective analogue audio evaluation which indicates that, just prior to digital ToA, analogue audio quality is audibly degraded.

### 9.2.4 Terrain obstructed fast (TO)

Table 23 gives the subjective analogue audio evaluation which indicates that, just prior to digital ToA, analogue audio quality is audibly degraded.

## 9.3 Performance in the presence of independently faded interference

This test measured system performance and recorded analogue audio in Gaussian noise and Rayleigh fading, in the presence of independently faded first-adjacent, second-adjacent, and co-channel hybrid IBOC interferers. Each interferer was passed through the same type of Rayleigh fading channel as the desired signal; however, all signals were independently faded, and were therefore uncorrelated.

### 9.3.1 Single first-adjacent interference

In the United States of America, properly spaced Class B stations are protected to the 54 dBu contour from first-adjacent channel interference exceeding 48 dBu in 50% of the locations for 10% of the time. As a result, tests were performed with first-adjacent hybrid interferers of varying power, up to a level that is 6 dB below that of the desired signal. The block error rate results are shown in Fig. 35 and summarized in Table 23. As might be expected, performance degrades as the interference level increases from  $-30 \text{ dB}_{\text{des}}$  to  $-6 \text{ dB}_{\text{des}}$ . However, the first-adjacent cancellation algorithm employed in the receiver ensures superior system performance, even with a high-level first-adjacent interferer in an urban fast-fading environment. Table 23 gives the subjective analogue audio evaluation, which indicates that, just prior to digital ToA, analogue audio quality is audibly degraded for all levels of first adjacents.

### 9.3.2 Single co-channel interference

In the United States of America, properly spaced Class B stations are protected to the 54 dBu contour from co-channel interference exceeding 34 dBu in 50% of the locations for 10% of the time. This means that 90% of the time at the 54 dBu contour the  $D/U$  exceeds 20 dB. Based on this information, a number of observations can be made regarding the character of co-channel interference. A hybrid co-channel interferer should have a minimal effect on the performance of the desired digital signal, since it will usually be at least 20 dB lower in power than the digital sidebands at the 54 dBu analogue protected contour. This has been verified via laboratory test. A  $-20 \text{ dB}_{\text{des}}$  hybrid co-channel interferer was applied to the desired hybrid signal in an urban fast-fading environment. The block error rate results are shown in Fig. 35 and are summarized in Table 23. Figure 36 indicates that adding a  $-20 \text{ dB}_{\text{des}}$  hybrid co-channel interferer degrades performance by only about 1 dB. Figure 35 also shows that, even if the level of the co-channel interferer were increased to  $-10 \text{ dB}_{\text{des}}$ , the incremental degradation would be limited to less than 3 dB. Table 23 gives the subjective analogue audio evaluation which indicates that, just prior to digital ToA, analogue audio quality is audibly degraded for a  $-20 \text{ dB}_{\text{des}}$  co-channel interferer. For a  $-10 \text{ dB}_{\text{des}}$  co-channel interferer, analogue audio quality is degraded beyond the point of failure before the digital audio even reaches its ToA.

FIGURE 36  
 Block error rate results of the hybrid system with an independently faded  
 10-channel interferer

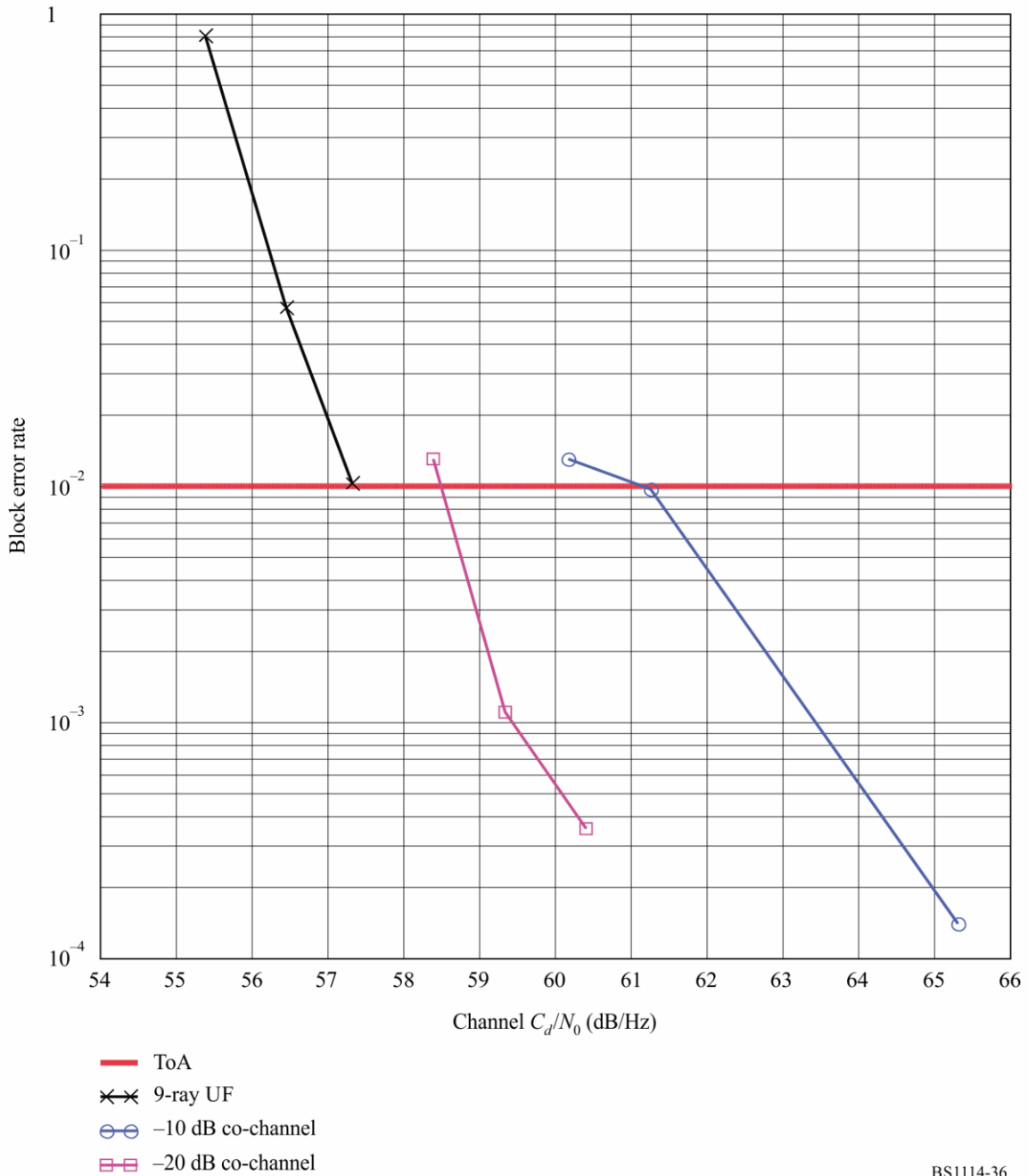

BS1114-36

### 9.3.3 Single second-adjacent interference

A hybrid IBOC second-adjacent interferer may have a slight effect on digital performance, since interference side lobes could spill into the desired digital sidebands. This effect has been quantified in laboratory tests. A single +20 dB hybrid second-adjacent interferer was applied to the desired hybrid signal in an urban fast-fading environment. The block error rate results are shown in Fig. 37 and are summarized in Table 23. Figure 37 indicates that adding a +20 dB hybrid second-adjacent interferer degrades performance by about 2 dB. Table 23 gives the subjective analogue audio evaluation which indicates that, just prior to digital ToA, analogue audio quality is audibly degraded.



FIGURE 37  
 Block error rate results of the hybrid system with an independently faded second-adjacent interferer

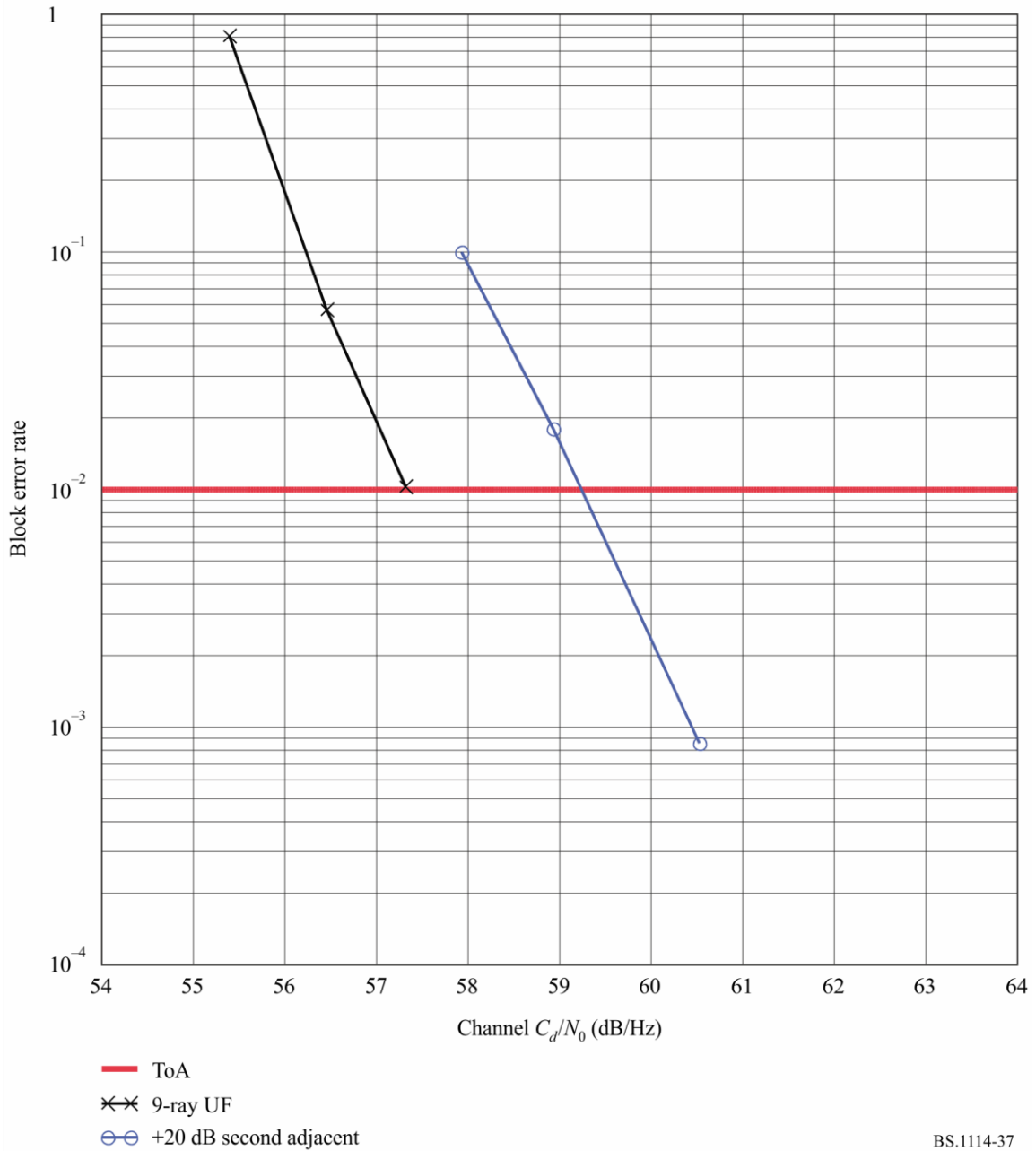

BS.1114-37

### 9.4 Conclusions

The recordings indicate that, in all environments tested, at the point where the digital signal begins to degrade, the corresponding analogue audio itself exhibits audible degradation. This implies that analogue audio is degraded at signal levels where digital audio degradation is not yet perceptible. As a result, up to the point of digital ToA, the performance of the digital signal surpasses that of the existing analogue signal. And when the digital signal finally begins to exhibit degradation, the IBOC receiver will automatically change to its analogue signal. Therefore, the performance of the Digital System C is better than the performance of existing analogue FM service.

## Annex 5

### Digital System G

#### 1 Introduction

Digital system G, also known as the DRM system, is designed to be used at any frequency in the VHF bands, with variable channelization constraints and propagation conditions throughout these bands. In order to satisfy these operating constraints, different transmission modes are available. A transmission mode is defined by transmission parameters classified in two types:

- signal bandwidth related parameters;
- transmission efficiency related parameters.

The first type of parameter defines the total amount of frequency bandwidth for one transmission. Efficiency-related parameters allow a trade-off between capacity (useful bit rate) and ruggedness to noise, multipath and Doppler.

Digital System G is standardized at ETSI as ES 201 980V3.1.1 (2009.08) “Digital Radio Mondiale (DRM); System specification”.

Digital System G has a number of robustness modes, each designed for different bands and propagation conditions, as illustrated in Table 24.

TABLE 24

**Robustness mode uses**

<b>Robustness mode</b>	<b>Typical propagation conditions</b>
A	Gaussian channels, with minor fading
B	Time and frequency selective channels, with longer delay spread
C	As robustness mode B, but with higher Doppler spread
D	As robustness mode B, but with severe delay and Doppler spread
E	Time and frequency selective channels

DRM+ consists of robustness Mode E and is designed for all the VHF bands and is the subject of this Recommendation as Digital System G.

#### 2 System architecture

Figure 38 describes the general flow of different classes of information (audio, data, etc.) and does not differentiate between different services that may be conveyed within one or more classes of information.

FIGURE 38

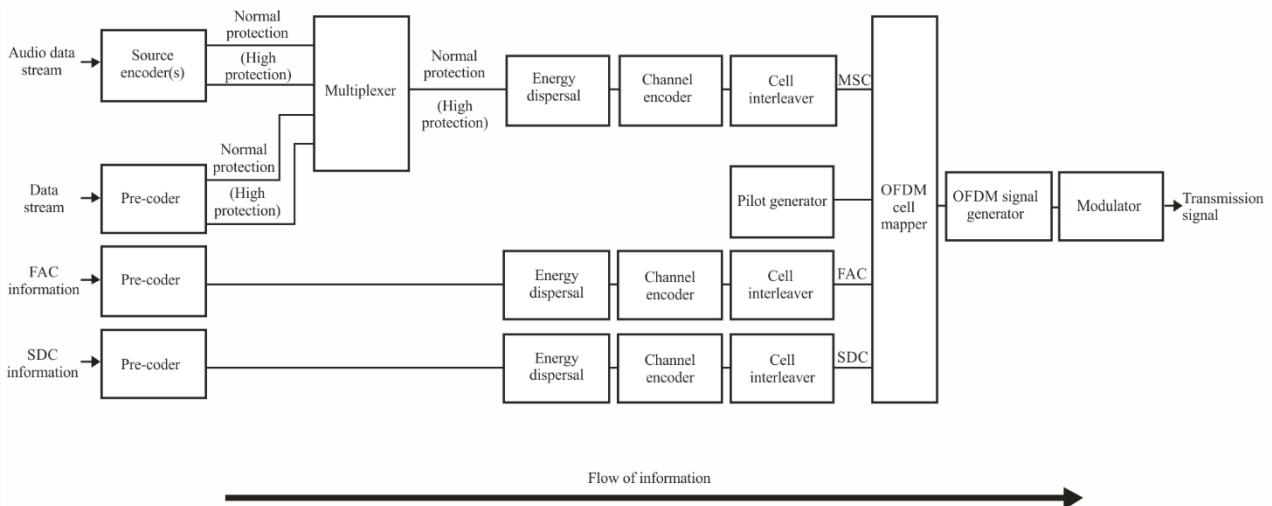

BS.1114-38

Figure 38 describes the general flow of the different classes of information (audio, data, ...) from encoding on the left to a transmitter on the right. Although a receiver diagram is not included it would represent the inverse of the process shown in this diagram.

- on the left are two classes of input information: the encoded audio and data that are combined in the main service multiplexer, and the information channels that bypass the multiplexer that are known as the FAC and SDC;
- the audio source encoder and the data pre-coders ensure the adaptation of the input streams onto an appropriate digital format. Their output may comprise two parts requiring two different levels of protection within the subsequent channel encoder;
- the multiplexer combines the protection levels of all data and audio services;
- the energy dispersal provides a deterministic, selective complementing of bits in order to reduce the possibility that systematic patterns result in unwanted regularity in the transmitted signal;
- the channel encoder adds redundant information as a means for error correction and defines the mapping of the digitally encoded information into QAM cells. The system has the capability, if a broadcaster desires, to convey two categories of “bits”, with one category more heavily protected than the other;
- cell interleaving spreads consecutive QAM cells onto a sequence of cells, quasi-randomly separated in time and frequency, in order to provide an additional element of robustness in the transmission of the audio in time-frequency dispersive channels;
- the pilot generator injects information that permits a receiver to derive channel-equalization information, thereby allowing for coherent demodulation of the signal;
- the OFDM cell mapper collects the different classes of cells and places them on a time-frequency grid;
- the OFDM signal generator transforms each ensemble of cells with the same time index to a time domain representation of the signal, containing a plurality of carriers. The complete time-domain OFDM symbol is then obtained from this time domain representation by inserting a guard interval – a cyclic repetition of a portion of the signal;
- the modulator converts the digital representation of the OFDM signal into the analogue signal that will be transmitted via a transmitter/antenna over the air. This operation involves

frequency up-conversion, digital-to-analogue conversion, and filtering so that the emitted signal complies with ITU-R spectral requirements.

### **3 Audio coding, text messages and packet data**

#### **3.1 Audio**

Within the constraints of broadcasting regulations in broadcasting channels in the VHF bands and the parameters of the coding and modulation scheme applied, the bit rate available for audio coding is in the range from 37 kbit/s to 186 kbit/s.

In order to offer optimum quality at a given bit rate, the system offers different audio coding schemes:

- a subset of MPEG-4 AAC (Advanced Audio Coding) including error robustness tools for generic mono and stereo audio broadcasting;
- spectral band replication (SBR), an audio coding enhancement tool that allows the full audio bandwidth to be achieved at low bit rates;
- parametric stereo (PS), an audio coding enhancement tool relevant to SBR that allows for stereo coding at low bit rates;
- MPEG surround (MPS), an audio coding enhancement tool that allows for multichannel coding at low bit rates.

AAC is highly optimized in terms of coding efficiency and according to information theory this should lead to the fact that the entropy of the bits is nearly equal. If this assumption is true, then the channel coding must be optimized such that the total amount of residual errors usually referred to as bit error rate (BER) is minimized. This criterion can be fulfilled by a channel coding method called equal error protection (EEP), where all information bits are protected with the same amount of redundancy.

However, the audible effects of errors are not independent of the part of the bitstream that was hit by the error. The optimized solution to cope with this unequal error sensitivity is called unequal error protection (UEP). In such a system, higher protection is assigned to the more sensitive information, whereas lower protection is assigned to the less sensitive part of the bit stream.

To accommodate UEP channel coding, it is necessary to have frames with a constant length and a UEP profile that is constant as well for a given bit rate. Since AAC is a coding scheme with a variable length, Digital System G groups several coded frames together to build one audio super frame. The bit rate of the audio super frame is constant. Since the channel coding is based on audio super frames, the audio super frames themselves consist of two parts: a higher protected part and a lower protected part. Therefore, the coded audio frames have to be split into these two parts.

The bit-stream transport format of MPEG AAC has been modified to meet the requirements of Digital System G (audio superframing). Unequal error protection (UEP) can be applied to improve the system behaviour in error-prone channels.

#### **3.2 Text message application**

Text messages can provide a highly valuable additional element to an audio service without consuming much data capacity. The text message is a basic part of Digital System G and consumes only 320 bits/s. This capacity can be saved if the service provider does not use text messaging.

### 3.3 Packet data mode

Data services generally consist of either streams of information, in either synchronous or asynchronous form, or files of information. Digital System G provides a generalized packet delivery system which allows the delivery of asynchronous streams and files for various services in the same data stream and allows the bit rate of the (synchronous) data stream to be shared on a frame-by-frame basis between the various services. The data stream may be provided with additional error control by the addition of forward error correction. Services can be carried by a series of single packets or as a series of data units. A data unit is a series of packets that are considered as one entity with regard to error handling – one received incorrect packet within a data unit causes the whole data unit to be rejected. This mechanism can be used to transfer files and also to allow simpler synchronization of asynchronous streams. The packet data mode of Digital System G is configurable by the broadcaster to allow optimized use of any capacity: both the packet length and strength of the forward error protection may be varied and signalled to receivers.

## 4 Multiplex, including special channels

Receivers must be easy to use. Digital System G provides signalling data to allow the listener to access the service he wants with a simple button press, and to allow the radio to track the broadcast to find the best frequency at all times and so leave the listener free to enjoy the programme.

DRM uses a combination of techniques to provide user friendliness. First, the total data capacity is divided into a multiplex of three sub-channels:

- the fast access channel (FAC);
- the service description channel (SDC);
- the main service channel (MSC).

The FAC contains useful information to allow the receiver to find services of interest to the listener quickly. For example, the receiver can scan the bands looking for services with a particular programme type or in a particular language. It also contains information about the broadcast mode to allow further decoding of the signal.

The SDC contains further information about the service (or multiplex of services – up to four) to enhance user friendliness. This includes a label of up to 16 characters (the UTF-8 coding standard is used so all characters are available, not just Latin-based ones) and how to find alternative sources of the same data, and gives attributes to the services within the multiplex. The size of the SDC varies according to the mode.

Alternative frequency checking may be achieved, without loss of service, by keeping the data carried in the SDC quasi-static. Therefore, the data in the SDC frames has to be carefully managed.

The MSC contains the audio and/or data services. The overall frame structure is designed to allow a receiver to jump to an alternate frequency and back without losing any data from the MSC. This means that when a number of frequencies are needed to provide the service, the receiver can always be checking for the best frequency and re-tune when necessary without any interruption to the audio. The SDC provides the list of frequencies and can also give a frequency schedule to allow for services that need different frequencies during the day and week.

By using these features, receivers can present services in a friendly way to the listener, who no longer has to be dependent on knowing the frequency or frequency schedule, and gets a positive confirmation from the displayed label that he is tuned to the service he wants.

The main service channel (MSC) contains the data for all the services contained in the multiplex. The multiplex may contain between one and four services, and each service may be either audio or data. The gross bit rate of the MSC is dependent upon the selected transmission parameters.

The MSC contains between one and four streams. Each stream is divided into logical frames. Audio streams comprise compressed audio and optionally they can carry text messages. Data streams may be composed of data packets, carrying information for up to four “sub-streams”. An audio service comprises one audio stream and optionally one data stream or one data sub-stream. A data service comprises one data stream or one data sub-stream.

Each logical frame generally consists of two parts, each with its own protection level. The lengths of the two parts are independently assigned. Unequal error protection for a stream is provided by setting different protection levels to the two parts.

The logical frames are each 100 ms long. If the stream carries audio, the logical frame carries the data for either the first or the second part of one audio super frame containing the audio information for 200 ms duration. Since, in general, the stream may be assigned two protection levels, the logical frames carry precisely half of the bytes from each protection level.

The logical frames from all the streams are mapped together to form multiplex frames of the same duration, which are passed to the channel coder.

The multiplex configuration is signalled using the SDC. The multiplex may be reconfigured at transmission super frame boundaries. A reconfiguration of the multiplex occurs when the channel parameters in the FAC are changed, or when the services in the multiplex are reorganized. The new configuration is signalled ahead of time in the SDC and the timing is indicated by the reconfiguration index in the FAC.

## 5 Channel coding and modulation

### 5.1 Introduction

Because of the different needs of the three sub-channels, the MSC, SDC and FAC, these sub-channels apply different coding and mapping schemes. An overview of the encoding process is shown in Fig. 39.

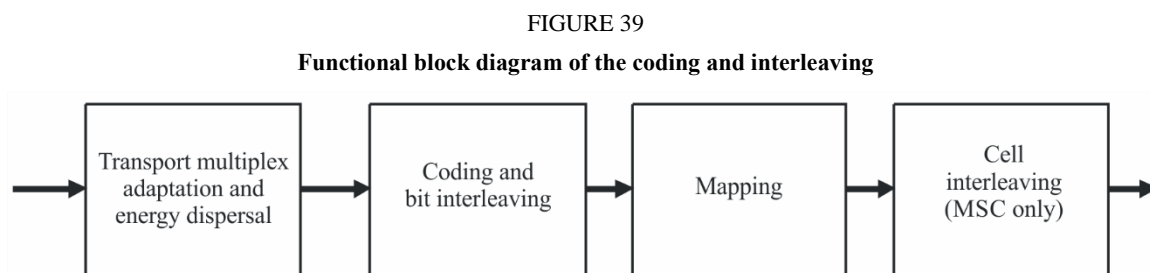

BS.1114-39

The coding is based on a multilevel coding scheme. Due to different error protection needs within one service or for different services within one multiplex different mapping schemes and combinations of code rates are applicable: unequal error protection (UEP) and equal error protection (EEP) are available. Equal error protection uses a single code rate to protect all the data in a channel. EEP is mandatory for the FAC and SDC. Instead of EEP, unequal error protection can be used with two code rates to allow the data in the main service channel to be assigned to the higher protected part and the lower protected part.

## 5.2 Multilevel coding

The channel encoding process is based on a multilevel coding scheme. The principle of multilevel coding is the joint optimization of coding and modulation to reach the best transmission performance. This denotes that more error-prone bit positions in the QAM mapping get a higher protection. The different levels of protection are reached with different component codes which are realized with punctured convolutional codes, derived from the same mother code.

The decoding in the receiver can be done either straightforwardly or through an iterative process. Consequently the performance of the decoder with errored data can be increased with the number of iterations and hence is dependent on the decoder implementation.

## 5.3 Coding the MSC

The MSC may use either 4-QAM or 16-QAM mapping: the lower constellation provides a more robust error performance whereas the higher constellation provides high-spectral efficiency.

In each case, a range of code rates is available to provide the most appropriate level of error correction for a given transmission. The available combinations of constellation and code rate provide a large degree of flexibility over a wide range of transmission channels. Unequal error protection can be used to provide two levels of protection for the MSC.

Two protection levels within one multiplex frame are possible resulting in the use of two overall code rates. The overall code rates and code rates for each level are defined in Tables 25 and 26. The protection level is signalled in the multiplex description data entity of the SDC.

TABLE 25

**Code rates for the MSC with 4-QAM**

Protection level	$R_{all}$	$R_0$
0	0.25	1/4
1	0.33	1/3
2	0.4	2/5
3	0.5	1/2

TABLE 26

**Code rate combinations for the MSC with 16-QAM**

Protection level	$R_{all}$	$R_0$	$R_1$	$R_{ytem}$
0	0.33	1/6	1/2	6
1	0.41	1/4	4/7	28
2	0.5	1/3	2/3	3
3	0.62	1/2	3/4	4

One or two overall code rates shall be applied to one multiplex frame. When using two overall code rates, both shall belong to the same constellation.

#### 5.4 Coding the SDC

The SDC uses 4-QAM mapping with code rate 0.5 or 0.25: a choice is available between greater capacity and a more robust error performance.

The constellation and code rate should be chosen with respect to the MSC parameters to provide more robustness for the SDC than for the MSC.

#### 5.5 Coding the FAC

The FAC shall use 4-QAM mapping with code rate 0.25.

### 6 Transmission structure

The propagation-related OFDM parameters of DRM Mode E are given in Table 27.

TABLE 27  
OFDM parameters

Elementary time period $T$	83 1/3 $\mu$ s
Duration of useful (orthogonal) part $T_u = 27 \cdot T$	2.25 ms
Duration of guard interval $T_g = 3 \cdot T$	0.25 ms
Duration of symbol $T_s = T_u + T_g$	2.5 ms
$T_g/T_u$	1/9
Duration of transmission frame $T_f$	100 ms
Number of symbols per frame $N_s$	40
Channel bandwidth $B$	96 kHz
Carrier spacing $1/T_u$	444 4/9 Hz
Carrier number space	$K_{min} = -106; K_{max} = 106$
Unused carriers	None

The transmitted signal is organized in transmission super frames which consist of four transmission frames.

Each transmission frame has duration  $T_f$ , and consists of  $N_s$  OFDM symbols.

Each OFDM symbol is constituted by a set of  $K$  carriers and transmitted with a duration  $T_s$ .

The spacing between adjacent carriers is  $1/T_u$ .

The symbol duration is the sum of two parts:

- a useful part with duration  $T_u$ ;
- a guard interval with duration  $T_g$ .

The guard interval consists in a cyclic continuation of the useful part,  $T_u$ , and is inserted before it.

The OFDM symbols in a transmission frame are numbered from 0 to  $N_s - 1$ .

All symbols contain data and reference information.

Since the OFDM signal comprises many separately modulated carriers, each symbol can in turn be considered to be divided into cells, each cell corresponding to the modulation carried on one carrier during one symbol.



An OFDM frame contains:

- pilot cells;
- control cells;
- data cells.

The pilot cells can be used for frame, frequency and time synchronization, channel estimation, and robustness mode identification.

## 7 Combined transmission of digital and analogue signals

A close placement of a Digital System G signal to an analogue FM signal is possible and can be flexibly configured depending on the existing use of spectrum. In this way, Digital System G may be introduced into the FM frequency bands.

FIGURE 40  
Example configuration for Digital System G (DRM mode E, left)  
and FM signal (right)

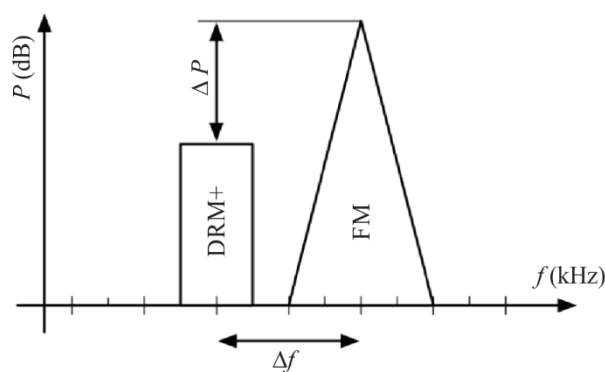

BS.1114-40

Figure 40 shows that the Digital System G signal can be placed closely to the left or right of the existing FM signal. To guarantee the respective protection levels and audio quality of the FM signal, the carrier frequency distance ( $\Delta f$ ) and the power level difference ( $\Delta P$ ) of the FM and the Digital System G signals can be planned accordingly.  $\Delta f$  can be chosen according to a 50 kHz channel raster.  $\Delta f \geq 150$  kHz is recommended.  $\Delta P$  can be varied flexibly; however, a  $\Delta P > 20$  dB is recommended for the minimum  $\Delta f = 150$  kHz.

Two transmission configurations are possible: the analogue and digital signals can be combined and transmitted via the same antenna; or the two signals can be transmitted from different antennas.

Different configurations for the Digital System G signal are possible. The Digital System G signal can have the same programme as the FM service, a different programme or the same programme as well as additional programmes. If the same programme is available via Digital System G and FM, the alternative frequency switching (AFS) flag should be sent in the service description channel (SDC) of the transmission multiplex allowing for a support of heterogeneous networks.

Figure 41 shows some example configurations.

FIGURE 41

Example configuration with Digital System G (left) and 2 FM stations (right)

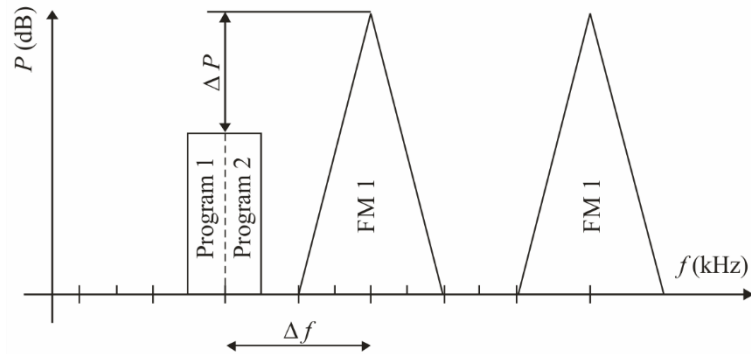

BS.1114-41

## 8 Simulated system performance

The radio-wave propagation in the VHF bands is characterized by diffraction, scattering and reflection of the electromagnetic waves on their way between the transmitter and the receiver. Typically the waves arrive at different times at the receiver (multipath propagation) resulting in more or less strong frequency-selective fading (dependent on system bandwidth). In addition movements of the receiver or surrounding objects cause a time variation of the channel characteristic (Doppler effect). In contrast to sky-wave propagation e.g. at short waves, ionospheric variations play no role for channel modelling for the VHF bands.

The approach is to use stochastic time-varying models with stationary statistics and define models for good, moderate and bad conditions by taking appropriate parameter values of the general model. One of those models with adaptable parameters is the wide sense stationary uncorrelated scattering model (WSSUS model). The justification for the stationary approach with different parameter sets is that results on real channels lead to BER curves between best and worst cases found in the simulation.

Additional variations of the short-term average power (slow or log normal fading) caused by a changing environment (e.g. building structure) or phenomena like sporadic-E layer propagation are not incorporated in the WSSUS model. Their effects, as well as the influence of disturbances like man-made noise, are normally integrated in the computation of the coverage probability during the network planning process.

Simulated system performance anticipating perfect channel estimation, ideal synchronization and the absence of phase noise and quantization effects has been performed. The signal power includes pilots and the guard interval. Channel decoding is assumed to be done with single stage Viterbi decoding for 4-QAM modulation and with a multistage decoder with two iterations for 16-QAM modulation.

The results in Table 28 are given for six channels, which represent different reception scenarios, whereby the associated robustness mode is E. The code rate is  $R = 0.33$  and the modulation is 4-QAM.

TABLE 28

**Required  $C/N$  for a transmission to achieve a BER =  $1 \times 10^{-4}$  after the channel decoder for the MSC (Mode E)**

Channel model	$C/N$
Channel 7 (AWGN)	1.3 dB
Channel 8 (urban) at 60 km/h	7.3 dB
Channel 9 (rural)	5.6 dB
Channel 10 (terrain obstructed)	5.4 dB
Channel 11 (hilly terrain)	5.5 dB
Channel 12 (SFN)	5.4 dB

The results in Table 29 are given for six channels which represent different reception scenarios, whereby the associated robustness mode is E. The code rate is  $R = 0.5$  and the modulation is 16-QAM.

TABLE 29

**Required  $C/N$  for a transmission to achieve a BER =  $1 \times 10^{-4}$  after the channel decoder for the MSC (Mode E)**

Channel model	$C/N$
Channel 7 (AWGN)	7.9 dB
Channel 8 (urban) at 60 km/h	15.4 dB
Channel 9 (rural)	13.1 dB
Channel 10 (terrain obstructed)	12.6 dB
Channel 11 (hilly terrain)	12.8 dB
Channel 12 (SFN)	12.3 dB

## Annex 6

### Digital System H

#### 1 Introduction

Digital System H, also known as Convergent Digital Radio (CDR) system, is designed to provide high-quality, multi-service digital audio broadcasting for vehicular, portable and fixed receivers at FM band (88 MHz to 108 MHz). In order to suit different application scenarios, different transmission modes are available. A transmission mode is defined by transmission parameters classified in two categories:

- signal bandwidth related parameters;
- transmission efficiency related parameters.

The first category of parameter defines the total amount of frequency bandwidth for one transmission. Efficiency-related parameters allow a trade-off between capacity (useful bit rate) and ruggedness to noise, multipath and Doppler.

Digital System H is standardized as GY/T 268.1-2013 (2013.08) “Digital audio broadcasting in FM band - Part 1: Framing structure, channel coding and modulation for digital broadcasting channel”.

## 2 System Structure

Figure 42 describes the general system structure and data flow of the Digital System H.

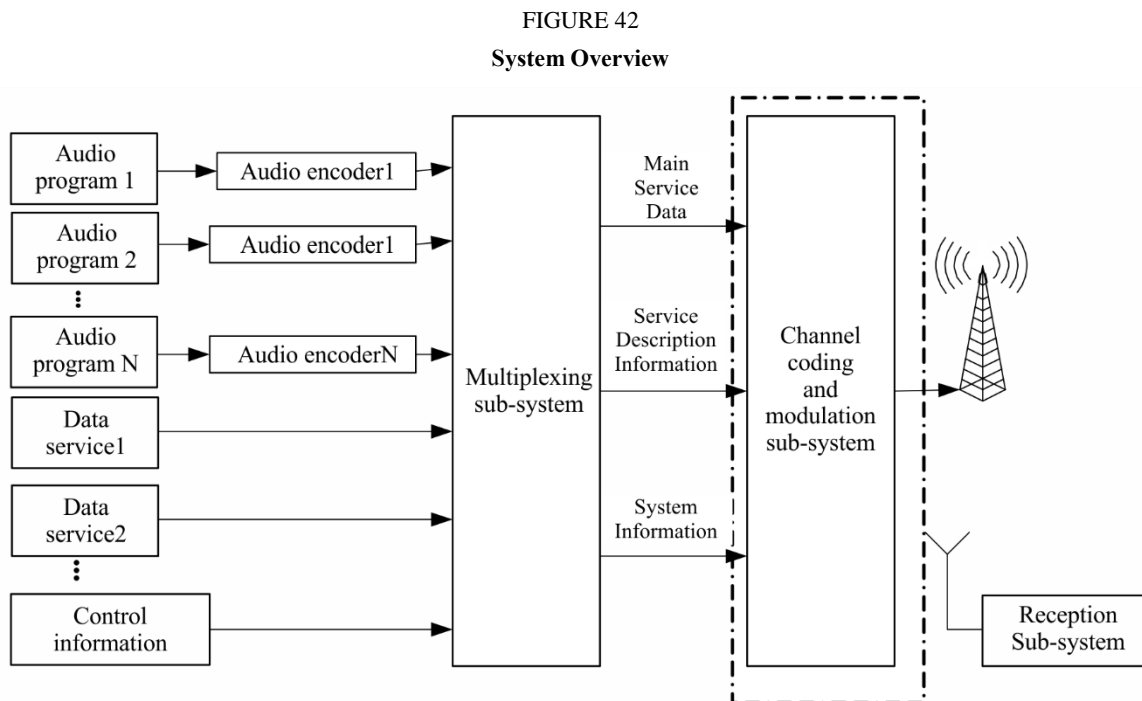

BS.1114-42

Digital System H supports simultaneous delivery of various digital audio streams and data streams. Various compressed audio services, data services and control information are combined and framed by multiplexing sub-system. The output of the multiplexing sub-system contains main service data (MSD), service description information (SDI) and system information (SI). The system defined main service channel (MSC), service description information channel (SDIC) and system information channel (SIC) to carry MSD, SDI and SI respectively. The RF signal will be produced when the output of multiplexing sub-systems are processed by channel coding and modulation sub-system. For each channel, forward error correction, constellation mapping and modulation scheme would be specified independently. The receiving sub-system completes demodulation of the transmitted signal.

Digital System H flexibly provides several spectrum-occupancy modes for different scenarios, the digital signal bandwidth can be 100 kHz or 200 kHz.

During the switch-off stage, the digital signal can be simulcast with analogue FM signal, in this case, the digital signal spectrum is divided into two parts, and the spectrum interval is 300 kHz or 200 kHz in which the analog stereo FM radio or mono FM broadcasting signals can be placed. When the switch-off is finished, the digital signal can be continuous; the signal bandwidth may be 100 kHz or 200 kHz.

Like other digital sound broadcasting systems, Digital System H also has several sub-carrier assignment schemes. Other than sub-carriers assigned for data transmission in OFDM block, some sub-carriers are assigned to transmit the system information of the transmission parameters, while some other sub-carriers are assigned to transmit pilots which are used for channel estimation.

### 3 Features of Digital System H

#### 3.1 Robustness

Digital System H uses OFDM modulation, two-dimensional frequency-time interleaving and LDPC as forward error correction code to offer improved performance in multipath fading environments. OFDM is a multi-carrier modulation method, and it has anti-multipath ability, especially adding a guard interval in the time domain. MSD are protected by the LDPC code. Therefore, a high quality signal is obtained at the receiver, even when under severe multipath propagation environment. SDI and SI is protected by convolutional code.

#### 3.2 Flexible spectrum-occupancy modes

Digital System H defines six spectrum-occupancy modes. Every mode defines the bandwidth of digital signal, the position of active sub-band and virtual sub-band. All the spectrum-occupancy modes are defined based on the sub-band (the bandwidth of the sub-band is 100 kHz). Each sub-band is divided into upper half-sub-band and lower half-sub-band which has the same bandwidth. All sub-carriers may be active sub-carriers or virtual sub-carriers in one sub-band, and all sub-carriers are virtual sub-carriers in upper half-sub-band or lower half-sub-band of certain active sub-bands in other sub-band for different spectrum mode.

The six different spectrum-occupancy modes are marked as A, B, C, D, E and F respectively as shown in Table 30. The spectrum A comprises one sub-band in which the sub-carriers are all active sub-carriers. The digital signal bandwidth of spectrum A is 100 kHz. The spectrum B comprises two sub-bands and the total digital signal bandwidth is 200 kHz. The spectrum C comprises four sub-bands in which the sub-carriers in lower half-sub-band of the first and the sub-carriers in upper half-sub-band of the fourth sub-band are all active sub-carriers, while the sub-carriers of the second and the third sub-band are all virtual sub-carriers, so the digital signal bandwidth of spectrum C is 100 kHz. The spectrum D comprises five sub-bands in which the sub-carriers in the first and the fifth sub-bands are all active sub-carriers, while the sub-carriers from the second to the fourth sub-bands are all virtual sub-carriers, the digital signal bandwidth of spectrum D is 200 kHz.

TABLE 30

Spectrum-occupancy mode

Spectrum-occupancy mode index	position										
	-5	-4	-3	-2	-1	1	2	3	4	5	$N_I$
A	DB1(L)	DB1(U)	DB2(L)	DB2(U)	DB3(L)	DB3(U)	DB4(L)	DB4(U)	DB5(L)	DB5(U)	1
B	0	DA1(L)	DA1(U)	DA2(L)	DA2(U)	DA3(L)	DA3(U)	DA4(L)	DA4(U)	0	2
C	0	DA1(L)	DA1(U)	DA2(L)	DA2(U)	DA3(L)	DA3(U)	DA4(L)	DA4(U)	0	1
D	DB1(L)	DB1(U)	DB2(L)	DB2(U)	DB3(L)	DB3(U)	DB4(L)	DB4(U)	DB5(L)	DB5(U)	2
E	DB1(L)	DB1(U)	DB2(L)	DB2(U)	DB3(L)	DB3(U)	DB4(L)	DB4(U)	DB5(L)	DB5(U)	1
F	0	DA1(L)	DA1(U)	DA2(L)	DA2(U)	DA3(L)	DA3(U)	DA4(L)	DA4(U)	0	2

Note – L indicates lower half sub-band, U indicates upper half sub-band.

Spectrum-occupancy modes of C/D/E/F are simulcast modes with existing FM signal (stereo or mono FM), see Fig. 43, which provide smooth evolution from current analogue to fully digital broadcasting for the FM broadcasters. Broadcasters can choose one of the spectrum-occupancy mode of C/D/E/F according to their own conditions and that of adjacent stations. During this period, the existing analogue-only receivers can continuously operate for the host FM signal, while the new digital

receivers can decode both the digital services as well as the host analogue FM. In the future, when the market is fully capable of receiving digital signals, broadcasters may switch to the spectrum mode of A or B.

FIGURE 43

Simul-casting spectrum diagram illustration

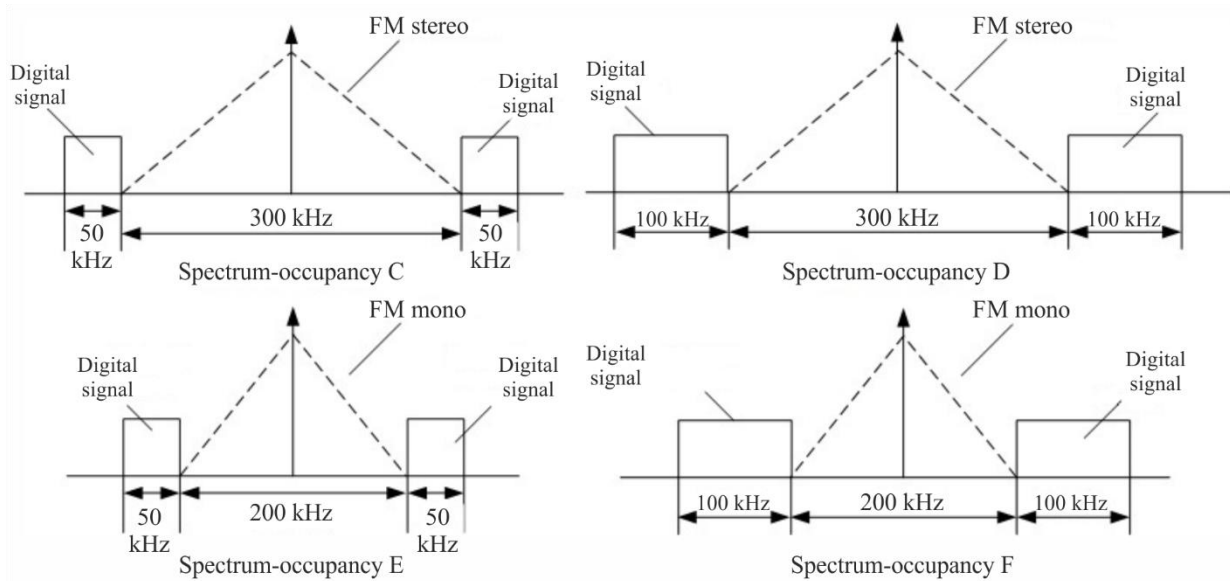

BS.1114-43

### 3.3 Various transmission modes

Digital System H defines three transmission modes. The system parameters of each transmission modes are given in Table 31.

In this Table, time unit is defined  $T = 1/816000s$ , all of the time-related parameter values can be expressed in multiple of  $T$  or approximate number of milliseconds.

TABLE 31

OFDM parameters for different transmission modes

Parameter	Symbol	Transmission mode 1	Transmission mode 2	Transmission mode 3
OFDM data body length (ms)	$T_u$	2.51 (2048T)	1.255 (1024T)	2.51 (2048T)
Data body cyclic prefix length (ms)	$T_{cp}$	0.2941 (240T)	0.1716 (140T)	0.0686 (56T)
OFDM symbol period (ms)	$T_s = T_{cp} + T_u$	2.804 (2288T)	1.426 (1164T)	2.5786 (2104T)
OFDM symbol sub-carrier interval (Hz)	$\Delta f$	398.4375	796.8750	398.4375
Beacon cyclic prefix length (ms)	$T_{Bcp} = T_{sf} - T_s \times S_N - T_u$	0.4706 (384T)	0.4069 (332T)	0.2059 (168T)
Beacon length (ms)	$T_B = T_{Bcp} + T_u$	2.9804 (2432T)	1.6618 (1356T)	2.7157 (2216T)

TABLE 31 (end)

Parameter	Symbol	Transmission mode 1	Transmission mode 2	Transmission mode 3
Synchronization signal sub-carrier interval (Hz)	$(\Delta f)_b$	796.875	1593.75	796.875
OFDM symbol number of each sub-frame	$S_N$	56	111	61
Sub-frame length (ms)	$T_{sf}$	160 (130560T)	160 (130560T)	160 (130560T)
Active sub-carrier number <sup>1</sup>	$N_v$	242	122	242

NOTE – When the sub-carriers in upper half-sub-band and lower half-sub-band of an active sub-band are not wholly virtual sub-carrier,  $N_v$  is the active sub-carriers number in the sub-band; when the sub-carriers in upper half-sub-band (or lower half-sub-band) of an active sub-band are all virtual sub-carrier, the active sub-carriers number in the sub-band is  $N_v / 2$ .

For each transmission mode, the duration of sub-logical frame is 160 ms. One Logical frame consists of four logical sub-frames and the duration of a logical frame is therefore 640ms.

### 3.4 Different FEC code rates and mapping schemes

Digital System H can delivery various audio services and data services such as text, still picture and traffic information simultaneously. The broadcaster can select different forward error correction code rate and the mapping scheme according their different requirements.

There are four options for MSC code rate: 1/4, 1/3, 1/2 and 3/4, and three modulation level: QPSK, 16QAM and 64QAM.

## 4 Source coding

Digital System H uses DRA+ <sup>(1)</sup> audio source coding algorithm. The audio codec supports the sampling rate from 16 kHz to 96 kHz, and the output bitrate range can be 16 ~384 kbit/s.

In fact, like all of the other digital radio systems, Digital System H can support any other audio codecs such as HE-AAC, AVS audio<sup>(2)</sup> as long as the bit-rate of audio stream doesn't exceed the net capacity of MSC, which is determined by different parameter sets including digital signal bandwidth, transmission mode, modulation level and FEC code rate.

Table 32 gives the net capacity of MSC in 100 kHz signal bandwidth. When the bandwidth of the digital signal is 200 kHz, the net capacities will double the values in Table 32.

TABLE 32

## Net capacity in 100 kHz bandwidth

Channel configuration		Net capacity (kbps)	
Modulation level	LDPC code rate	Transmission mode 1 and 2	Transmission mode 3
QPSK	1/4	36	39.6
QPSK	1/3	48	52.8
QPSK	1/2	72	79.2
QPSK	3/4	108	118.8
16QAM	1/4	72	79.2
16QAM	1/3	96	105.6
16QAM	1/2	144	158.4
16QAM	3/4	216	237.6
64QAM	1/4	108	118.8
64QAM	1/3	144	158.4
64QAM	1/2	216	237.6
64QAM	3/4	324	356.4

NOTE 1 – DRA+ is an audio coding standard (GD/J 058-2014) released by SAPPRFT China, which is based on DRA audio coding technology defined in Chinese GB/T 22726-2008, enhanced by spectral band replication (SBR) and parametric stereo (PS) to suit the low bitrate applications in digital radio services.

NOTE 2 – AVS audio is an audio coding scheme under standardization in China.

## 5 Multiplex frame and logical frame

Multiplexing sub-system encapsulates various audio services and data services in accordance with the multiplexing protocol and generates the multiplex frame composed of MSD, SDI and SI. The duration of multiplex frame is 640 ms.

Digital System H defines logical frame to carry the data of every multiplex frame. A logical frame can be divided into four logical sub-frame, which is the basic unit for sub-frame allocation (a kind of time interleaving), which is showed in Fig. 44, and see details in § 6.8.



FIGURE 44

Logical frame and sub-frame allocation

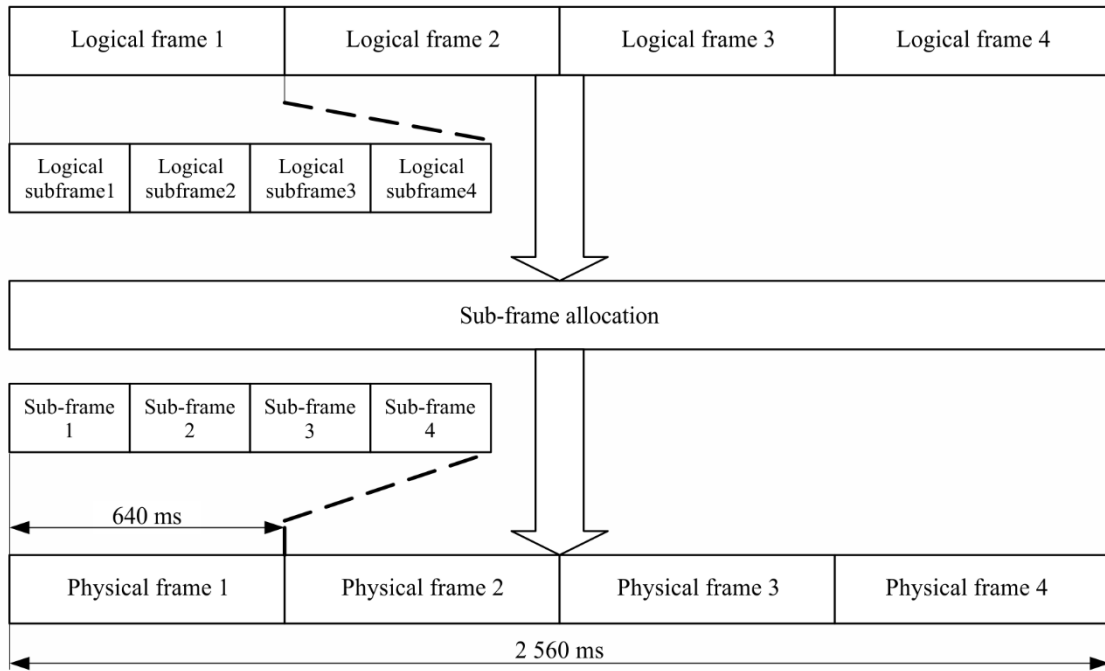

BS.1114-44

## 6 Channel encoding and modulation

Figure 45 shows the functional block diagram of channel encoding and modulation of Digital System H. The Figure describes the general flow of MSD, SDI and SI from encoding on the left to a transmitter on the right. MSD contains all the audio and data services to be transmitted. The gross bit rate of the MSD is dependent on different channel bandwidths, transmission modes, code rates and modulation levels. SDI contains further information about the description of MSD such as identification information to enhance user friendliness. This service identification information can be used for program selection at the receiving end. SI provides important information on modulation level, MSC FEC code rate, spectrum mode and other such parameters required for the de-modulation of MSD or SDI.

FIGURE 45

Channel encoding and modulation diagram

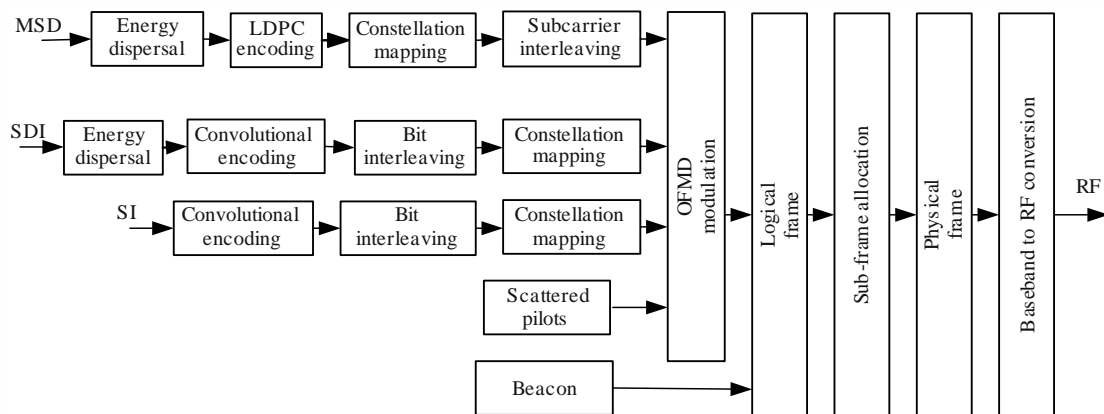

BS.1114-45

## 6.1 Energy dispersal

The purpose of the energy dispersal is to avoid the transmission of signal patterns which might result in an unwanted regularity in the transmitted signal. Energy dispersal shall be scrambled on MSD and SDI respectively by pseudo-random binary sequence (PRBS).

The polynomial for the PRBS generator is:  $x^{12}+x^{11}+x^8+x^6+1$ .

## 6.2 Channel coding

The channel encoding adds redundant information as a means for forward error correction. The LDPC code is used for MSD and convolutional encode is used for SDI and SI.

### 6.2.1 Convolutional encoding

SDI and SI are protected by 1/4 convolutional encode, which has 64 states, the corresponding octal generating polynomial is: 133, 171, 145, and 133 with initial state of all zeros.

### 6.2.2 LDPC encoding

Digital System H uses quasi-cyclic LDPC code to protect the MSC data. The code length is 9216 bits, and there are four code rates: 1/4, 1/3, 1/2, and 3/4. The different FEC parameters are given in Table 33.

TABLE 33  
LDPC coding parameters

LDPC code rate	Information bit length $k$ (bits)	Code word length $N$ (bits)
3/4	6912	9216
1/2	4608	9216
1/3	3072	9216
1/4	2304	9216

## 6.3 Bit interleaving

Block bit Interleaving is applied after convolutional encoding for SDI and SI. The interleaving block length is shown in Table 34 if the digital signal bandwidth is 100 kHz. When the digital signal bandwidth is 200 kHz the interleaving block length will be doubled.

TABLE 34  
Interleaving block length

Modulation	Transmission mode 1	Transmission mode 2	Transmission mode 3
QPSK	$1704 \times 2 = 3408$	$1576 \times 2 = 3152$	$1360 \times 2 = 2720$
16QAM	$1704 \times 4 = 6816$	$1576 \times 4 = 6304$	$1360 \times 4 = 5440$
64QAM	$1704 \times 6 = 10224$	$1576 \times 6 = 9456$	$1360 \times 6 = 8160$

The interleaving block length is 216 for SI regardless of the digital signal bandwidth.

## 6.4 Constellation mapping

SI use QPSK mapping while MSD and SDI support QPSK, 16QAM or 64QAM. The serial bit-sequence at the output of the LDPC coder or bit-leavers is mapping into the different constellation points in complex domain according different modulation level configurations.

Power normalization is applied to different constellation mapping schemes.

## 6.5 Active sub-carrier of OFDM symbol

Each OFDM symbol consists of continuous pilots, scattered pilots and data sub-carriers.

### 6.5.1 Continuous pilot

108 SI symbols are placed on the continuous pilots, the SI symbols are same in upper half-sub-band and lower half-sub-band. Table 35 provides continuous pilots position placed on columns in an OFDM symbols. Table 36 shows continuous pilots position placed on the number of OFDM symbol in a logical sub-frame.

For example, in transmission mode 1, the 108 SI symbols are placed at the position specified by Table 35 of 1<sup>st</sup>~the 27<sup>th</sup> OFDM symbol in a logical sub-frame. The same 108 SI symbols are also placed at the specified position in Table 6 of the 28<sup>th</sup> ~ the 54<sup>th</sup> OFDM symbols in a logical sub-frame which means 108 SI symbols are repeated twice to ensure their ruggedness.

TABLE 35

Continuous pilots position in each OFDM symbol

Transmission mode	SI symbol position of lower half-sub-band	SI symbol position of upper half-sub-band
Transmission modes 1 and 3	11, 55, 75, 103	144, 164, 192, 228
Transmission mode 2	15, 43	84, 104

TABLE 36

The number of OFDM symbol carrying SI symbols in a logical sub-frame

	Transmission mode 1	Transmission mode 2	Transmission mode 3
Number of OFDM symbol	1~27 28~54	1~54 55~108	1~27 28~54

### 6.5.2 Scattered pilot

The scattered pilots can be used for frame, frequency and time synchronization, channel estimation.

Two pseudo-random sequences form a scattered pilot symbols after the QPSK mapping. Scattered pilot symbols are placed in the scattered pilots.

### 6.5.3 Data sub-carriers

The sub-carriers are data sub-carriers except virtual sub-carrier, continual pilot and scattered pilot in a OFDM symbol. SDS symbols and MSD symbols are placed in data sub-carrier.

After scrambling, encoding, interleaving and constellation mapping, the SDI symbols in one logical sub-frame are placed on the position as shown in Table 37. All data sub-carriers in the 1<sup>st</sup> ~ the  $N_{SDIS_n}$ <sup>th</sup>

OFDM symbols carry SDI symbols in one logical sub-frame. In the  $N_{SDISn+1}^{\text{th}}$  OFDM symbol, the 1<sup>st</sup>  $\sim N_{SDISactive}^{\text{th}}$  data sub-carriers also carry SDI symbols.

TABLE 37

**Data sub-carriers position carrying SDI symbols in a logical sub-frame**

Transmission mode 1		Transmission mode 2		Transmission mode 3	
$N_{SDISn}$	$N_{SDISactive}$	$N_{SDISn}$	$N_{SDISactive}$	$N_{SDISn}$	$N_{SDISactive}$
2	0	3	72	1	128

The remaining data sub-carriers carry the MSD symbols. Table 38 illustrates the number of MSD and SDI symbols in a logical frame.

TABLE 38

**Numbers of MSD and SDI symbols in a logical frame**

Transmission mode 1		Transmission mode 2		Transmission mode 3	
MSD	SDI	MSD	SDI	MSD	SDI
46080	1704	46080	1576	50688	1360

## 6.6 Sub-carriers interleaving for MSD symbols

The sub-carriers interleaving is applied for the data sub-carriers containing MSD symbols. The procedure is a kind of frequency-time interleaving according to the specified interleaving algorithm. The interleaving process is carried out among four sub-logical frames and different sub-bands.

The interleaving is processed by interleaving block. The Interleaving block length is 46080 for transmission mode 1 and 2, 50688 for transmission mode 3.

## 6.7 OFDM signal generation

OFDM Signal generation receives complex, frequency-domain, SDS symbols, SI symbols, frequency-time interleaved MSD symbols which are carried by OFDM active subcarrier, and outputs time-domain signal representing the digital radio signal.

## 6.8 Logical frame, sub-frame allocation and physical frame

In order to facilitate receiver synchronization, the logical sub-frame is built up with a regular frame structure. One logical sub-frame comprises a beacon and  $S_N$  OFDM symbols with cyclic prefix, and each four logical sub-frames constitute a logical frame. For details, please refer to Figs 44 and 46 respectively.

FIGURE 46  
Structure of one sub-frame

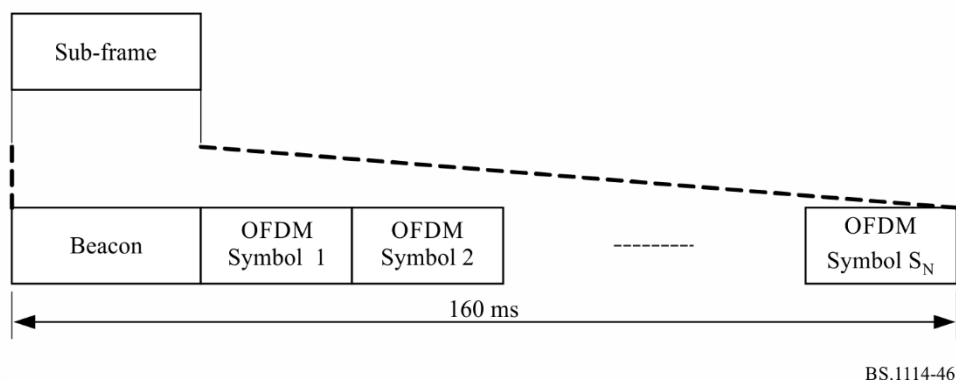

BS.1114-46

The beacon is also an OFDM symbol. A complex pseudo-random sequence is generated and placed on the beacon's sub-carriers. The generation polynomial is:

$$P_b(n) = \exp\left[-j(-1)^n 2\pi m \frac{n(n+1)/2}{N_{zc}}\right], n = 0, 1, \dots, L-1$$

when transmission mode 1 and 3 are used,  $N_{zc} = 967$ ,  $m = 48$ ; when transmission mode 2 is used,  $N_{zc} = 487$ ,  $m = 12$ . The  $L$  value is shown in Table 39.

TABLE 39

**L value**

Digital signal bandwidth	Transmission mode 1&3	Transmission mode 2
100 kHz	120	60
200 kHz	240	120

The duration of logical frame and physical frame are all 640 ms. Logical frame carries all data from multiplexing frames. Logical frame is transformed into physical frame after sub-frame allocation.

Digital System H has three kinds of sub-frame allocation mode. Sub-frame allocation is processed with one logical frame, or with two consecutive logical frames, or with four consecutive logical frames. Sub-frame allocation is a kind of time-interleaving. The sub-frame allocation mode 3 has longest interleaving time that is 2 560 ms.

Logical frame is transformed into physical frame after sub-frame allocation. Each physical frame carries all the data of a logical frame.

## 7 Spectrum Mask

In order to reduce the RF signal out-band power, a filter may be used for filtering the RF signal. The spectrum masks of a possible filter implementation are shown in Figs 47 to 52, respectively. The resolution bandwidth of signal power measurement is 1 kHz, 0 dB indicates in-band total power, Each breakpoint in the Figure is listed in Tables 40 to 45.

FIGURE 47

Spectrum mask of spectrum mode A

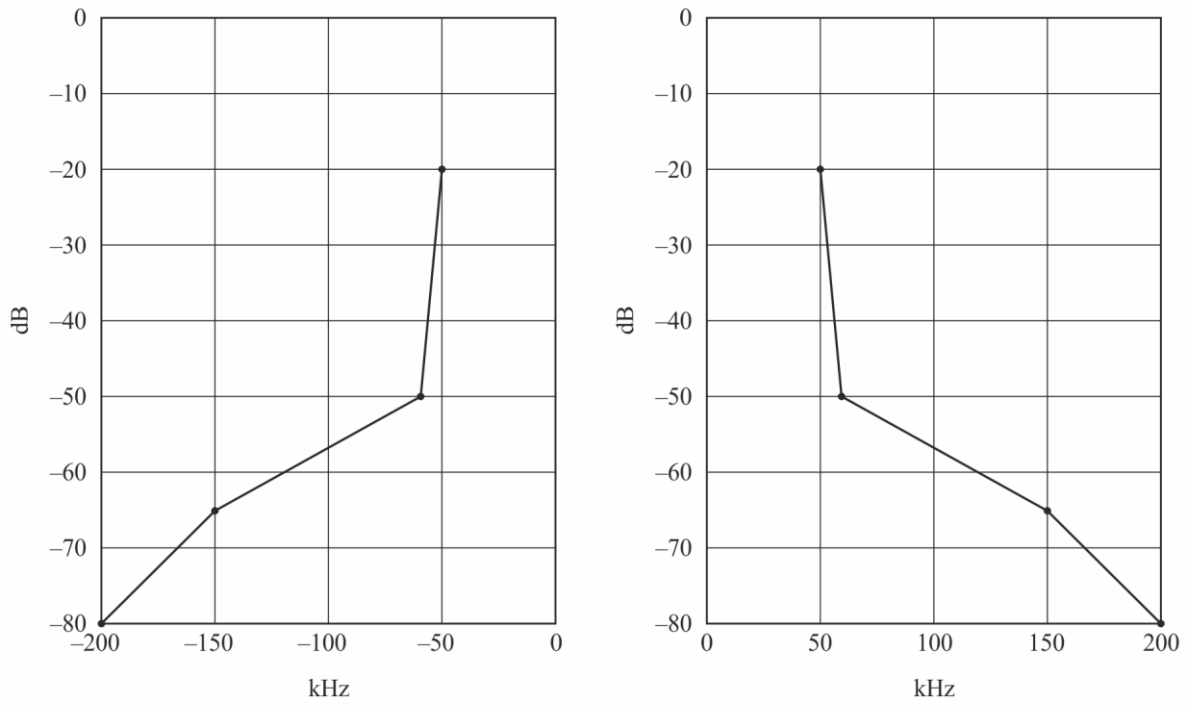

BS.1114-47

FIGURE 48

Spectrum mask of spectrum mode B

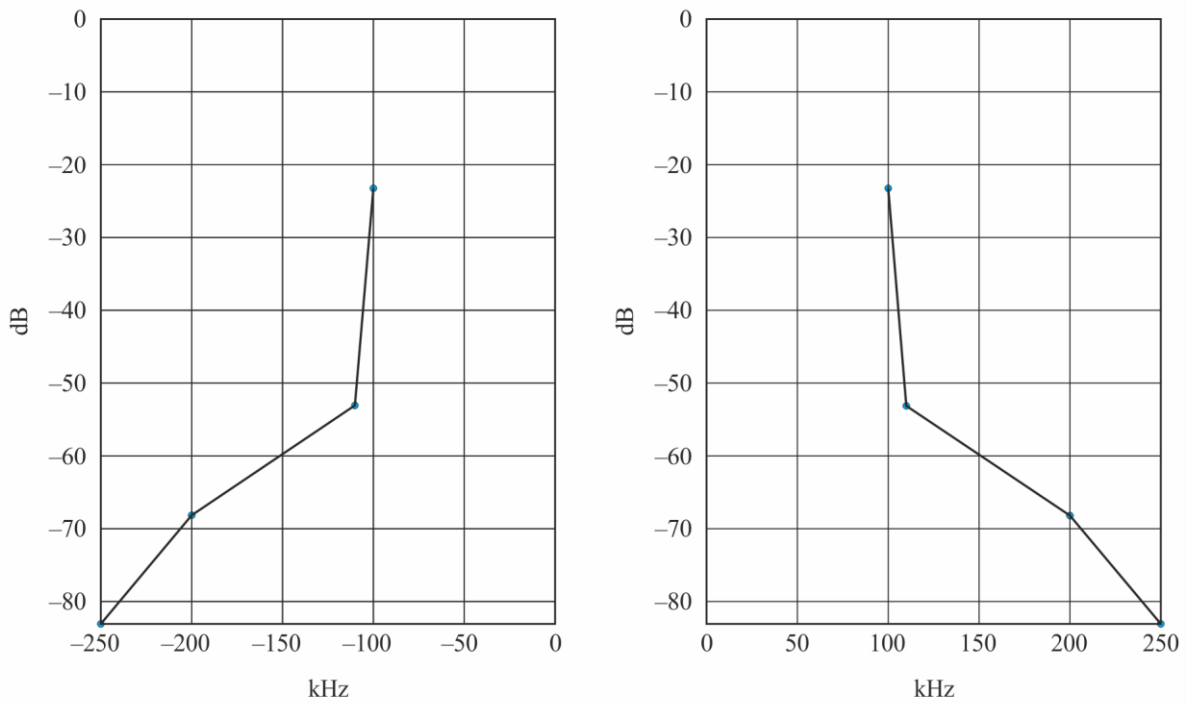

BS.1114-48

FIGURE 49

Spectrum mask of spectrum mode C

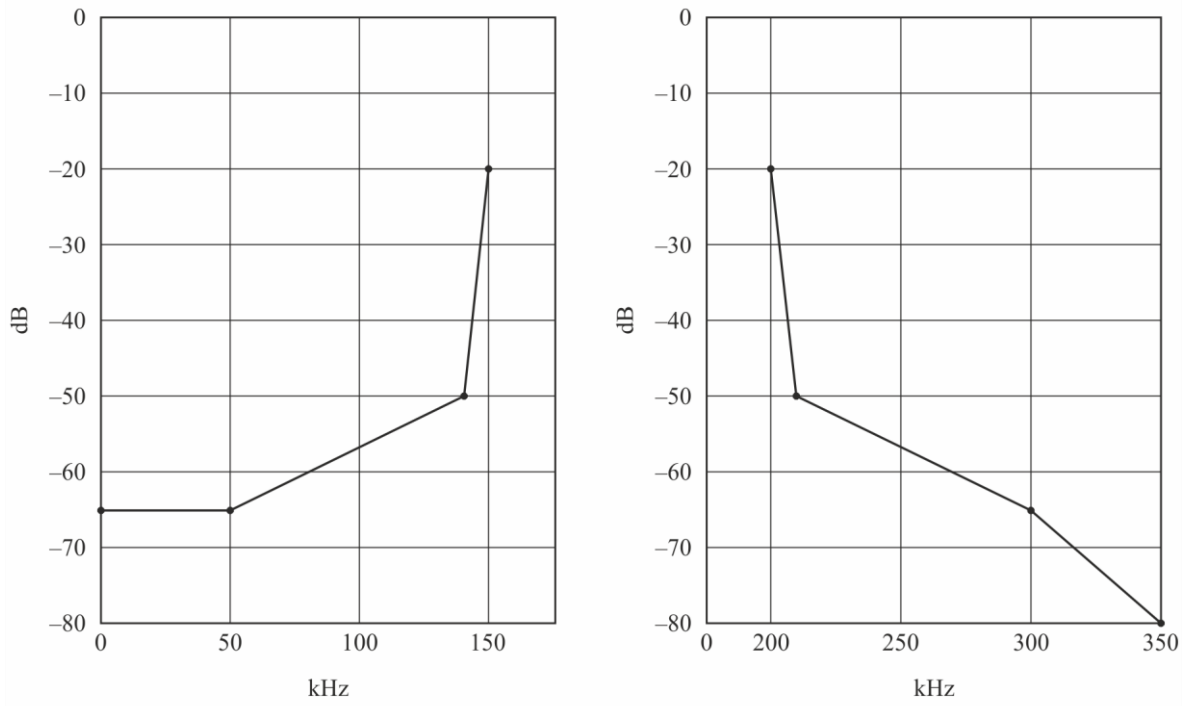

BS.1114-49

FIGURE 50

Spectrum mask of spectrum mode D

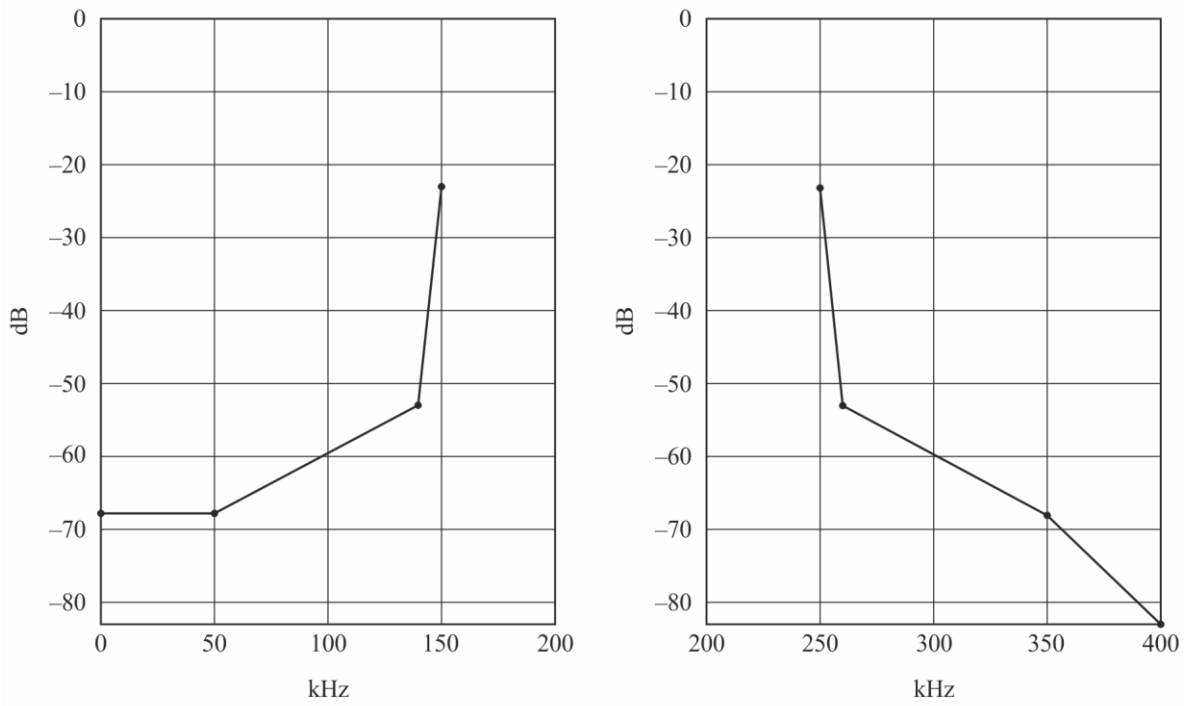

BS.1114-50

FIGURE 51

Spectrum mask of spectrum mode E

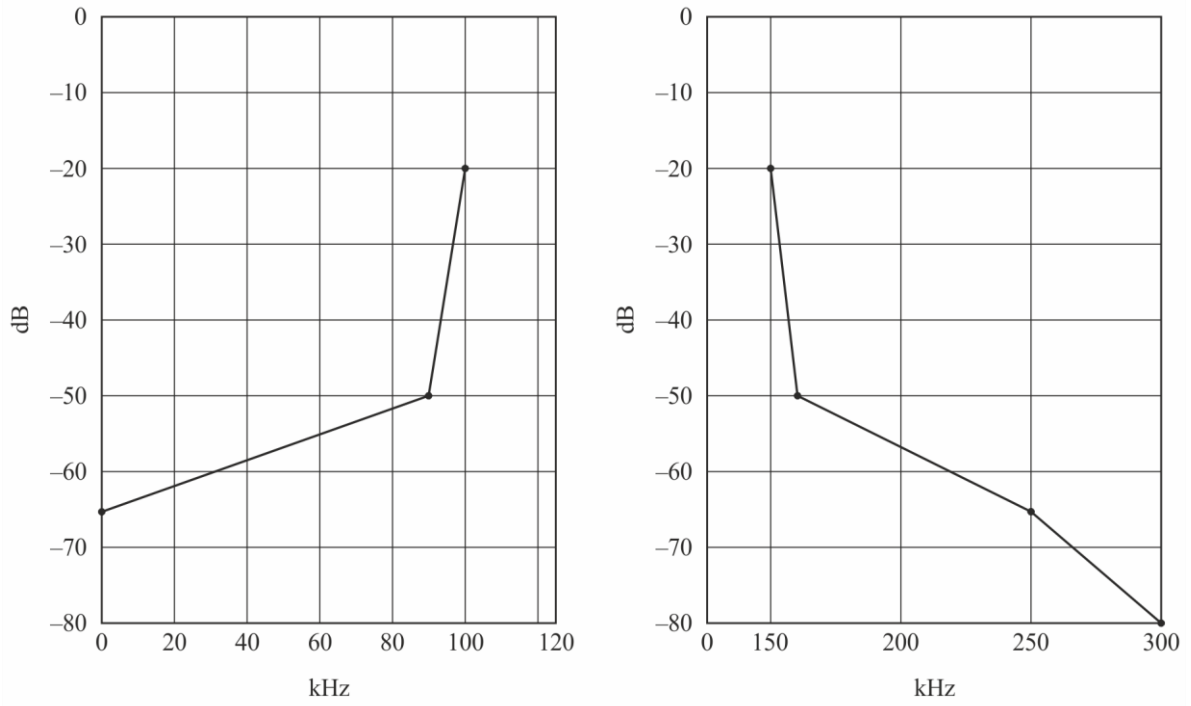

BS.1114-51

FIGURE 52

Spectrum mask of spectrum mode F

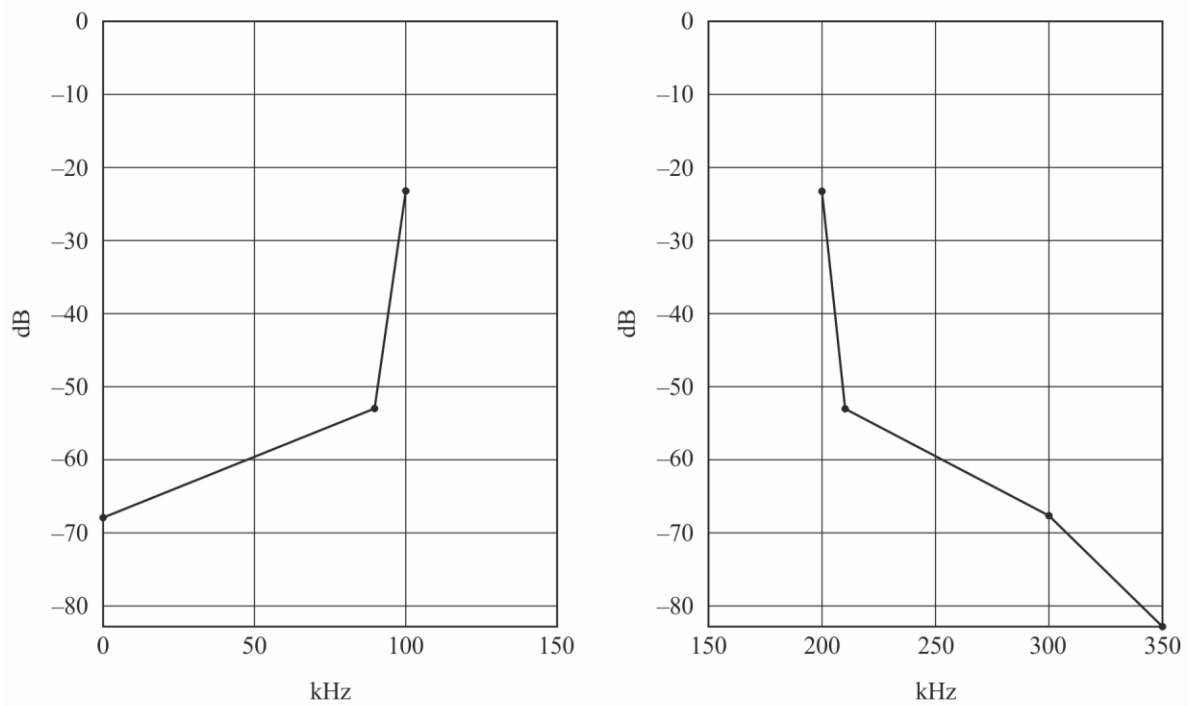

BS.1114-52



TABLE 40

**Breakpoints of spectrum mask when in-band power is defined as 0dB (Spectrum mode A)**

Frequency offset relative to centre frequency (kHz)	Relative level (dB)
-200	-80
-150	-65
-60	-50
-50	-20
50	-20
60	-50
150	-65
200	-80

TABLE 41

**Breakpoints of spectrum mask when in-band power is defined as 0dB (Spectrum mode B)**

Frequency offset relative to centre frequency (kHz)	Relative level (dB)
-250	-83
-200	-68
-110	-53
-100	-23
100	-23
110	-53
200	-68
250	-83

TABLE 42

**Breakpoints of spectrum mask when in-band power is defined as 0dB (Spectrum mode C)**

Frequency offset relative to centre frequency (kHz)	Relative level (dB)
0	-65
50	-65
140	-50
150	-20
200	-20
210	-50
300	-65
350	-80

TABLE 43

**Breakpoints of spectrum mask when in-band power is defined as 0dB (Spectrum mode D)**

<b>Frequency offset relative to centre frequency (kHz)</b>	<b>Relative level (dB)</b>
0	-68
50	-68
140	-53
150	-23
250	-23
260	-53
350	-68
400	-83

TABLE 44

**Breakpoints of spectrum mask when in-band power is defined as 0dB (Spectrum mode E)**

<b>Frequency offset relative to centre frequency (kHz)</b>	<b>Relative level (dB)</b>
0	-65
90	-50
100	-20
150	-20
160	-50
250	-65
300	-80

TABLE 45

**Breakpoints of spectrum mask when in-band power is defined as 0dB (Spectrum mode F)**

<b>Frequency offset relative to centre frequency (kHz)</b>	<b>Relative level (dB)</b>
0	-68
90	-53
100	-23
200	-23
210	-53
300	-68
350	-83

**8 Summary of laboratory test results**

Laboratory test has been carried out on Digital System H for variety of transmission conditions summarized below. Laboratory tests were conducted against random noise and multipath fading environment. The fading profiles used are denoted by urban at 60 km/h, rural at 150 km/h and were independently applied to the desired signal. The performance was evaluated by the  $C/N$  for a transmission to achieve a  $BER = 1 \times 10^{-4}$  after the channel decoder for the MSC.

**8.1 BER vs.  $C/N$  in a Gaussian channel**

Additive white Gaussian noise was added to set the  $C/N$  at the input of the receiver. The measurement results are shown in Fig. 53.

TABLE 46

**Transmission parameters for laboratory tests in Gaussian channel**

Spectrum mode	B (bandwidth: 200 kHz)
Transmission mode	1
Carrier modulations	QPSK, 16-QAM, and 64-QAM
Coding rates of inner code	1/2, 3/4

FIGURE 53

**BER vs.  $C/N$  in Gaussian channel**

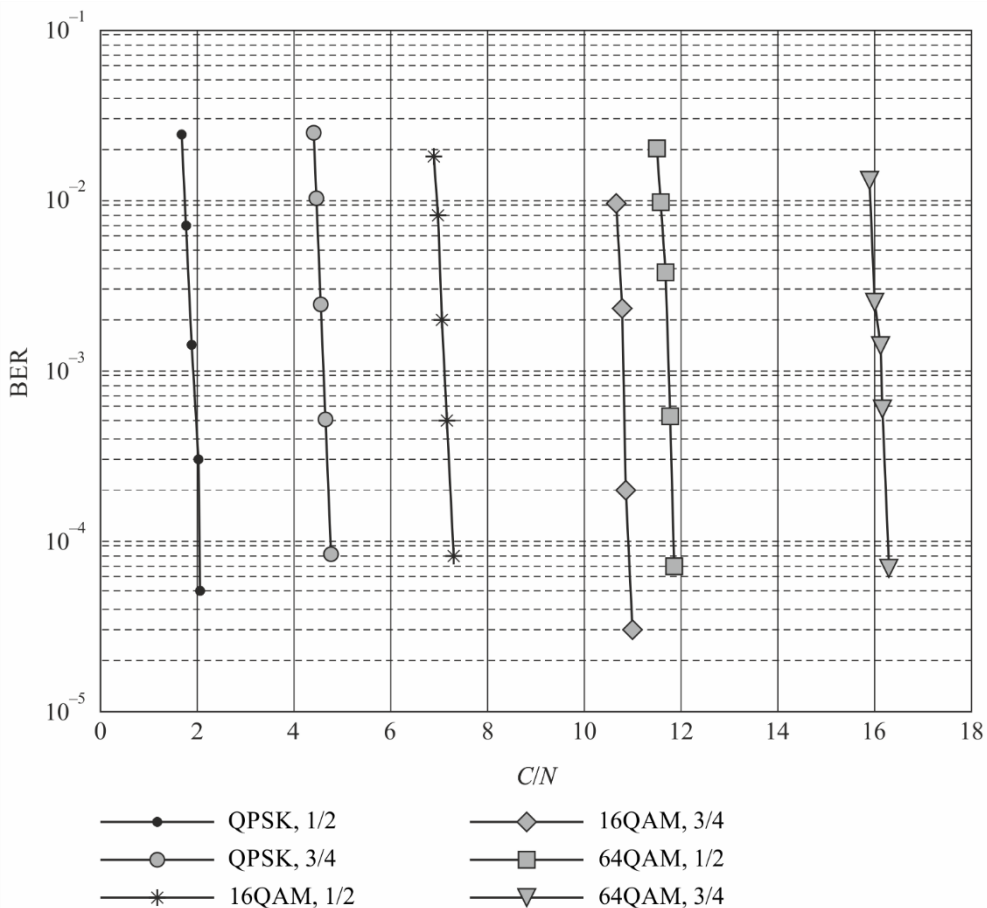

8.2 BER versus  $C/N$  in a Multipath channel

The measurement results in Figs 54 and 55 are given for urban at 60 km/h, rural at 150 km/h, respectively which represent different reception scenarios, whereby the associated robustness mode is shown as Table 47.

TABLE 47

Transmission parameters for laboratory tests in multipath channel

Spectrum mode	A	C
Transmission mode	1,2	1,2
Carrier modulations	QPSK	16QAM
Coding rates of inner code	3/4	1/2
Sub-frame allocation mode	1	

FIGURE 54

BER vs.  $C/N$  in multipath channel

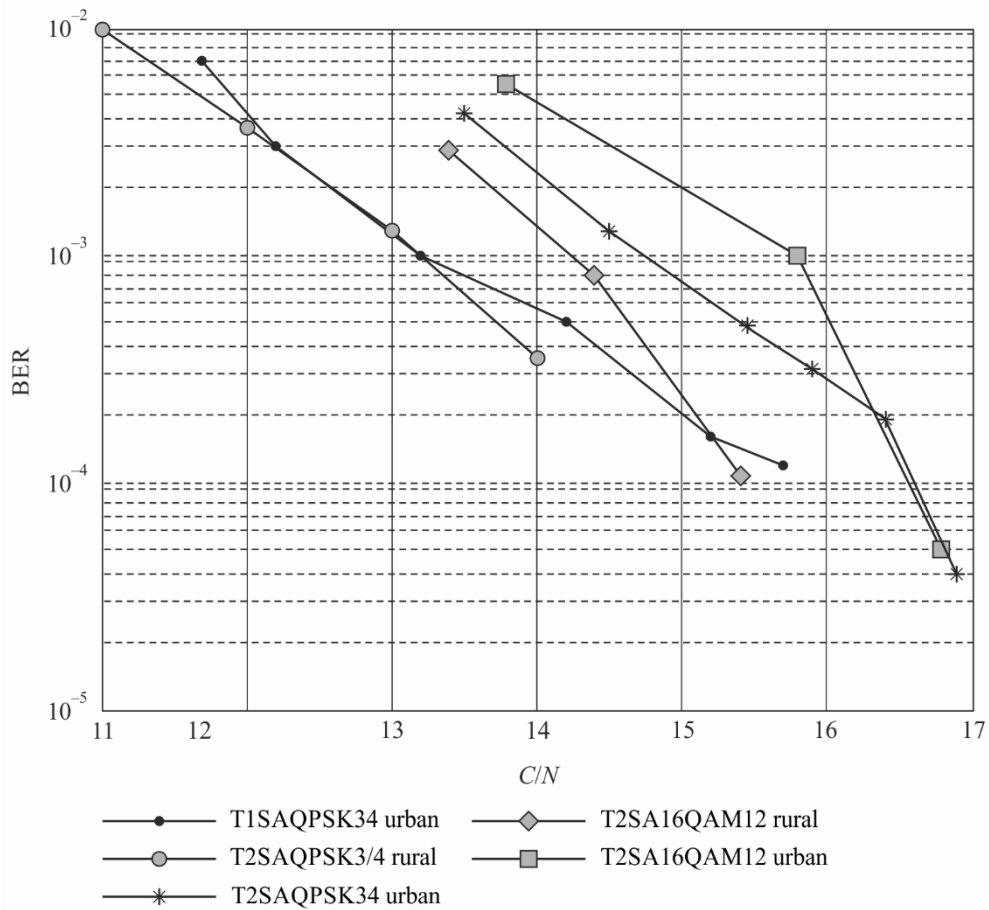
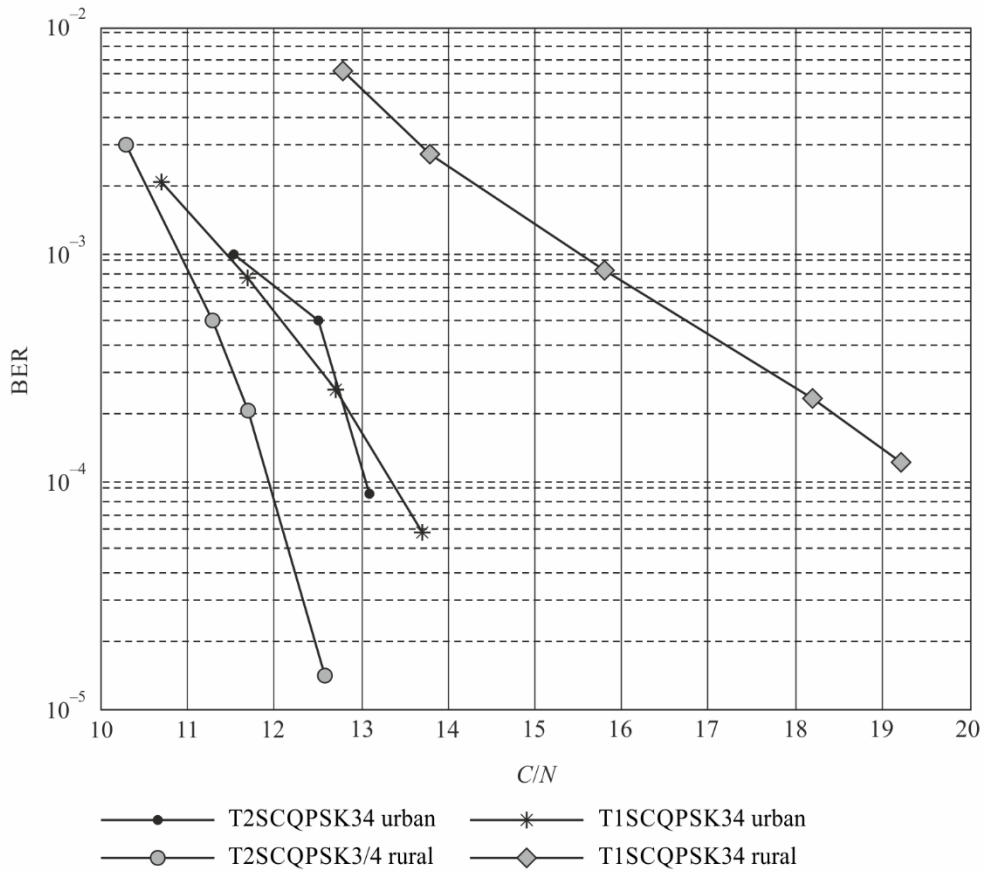

FIGURE 55  
BER vs.  $C/N$  in multipath channel



BS.1114-55

## Annex 7

### Digital System I

#### 1 Introduction

Digital System I, also known as RAVIS (Real-time AudioVisual Information System) was developed for provision of high quality multiservice sound and multimedia broadcasting to mobile, portable and fixed receivers in VHF frequency bands I and II (47-68/74 MHz and 87.5-108 MHz). Various transmission modes are available for different application scenario. Transmission mode is defined by two parameter categories:

- signal bandwidth parameters;
- effectiveness of bandwidth utilization parameters.

The first category defines the frequency bandwidth used for transmission, and the second category gives the tradeoff between data bitrate and stability in the presence of various interferences – Gaussian noise, multipath propagation, Doppler spreading.

Digital System I is adopted in Russian Federation National Standard GOST R 54309-2011 “Real-time audiovisual information system (RAVIS). The formation processes of frame structure, channel coding and modulation for the digital terrestrial narrowband radio broadcasting system in VHF band. Technical specifications”.

## 2 Architectural and protocol stack model

The basic service requirements for RAVIS are as follows:

- high spectral efficiency of the system;
- reliable mobile reception of video, audio and other services at velocities up to 200 km/h;
- short delay of reception starting or recovery of reception after interruption in complex conditions (for instance, after leaving the tunnel where signal reception was broken);
- providing high quality video broadcasting with frame sizes up to  $720 \times 576$ , frame rate up to 25 fps, multiple sound accompaniment channels;
- providing high quality audio broadcasting, including stereo sound with CD quality and multichannel sound 5.1;
- providing additional data services related or unrelated to video or audio programme, such as:
  - text messages;
  - still images;
  - slide-show;
  - traffic information, weather information, local news, etc.;
- EPG,
- providing conditional access to services;
- providing reliable emergency alerting service;
- SFN operation, including those along highways and railways.

System receiver should enable to receive new digital programmes and programmes from analogue FM-broadcasting station with automatic detection of the programme type.

At the present time the most perspective for utilization in RAVIS are audio codec HE-AAC (including SBR, PS, MPEG Surround techniques) and video codecs H.264/AVC, H.265/HEVC. Audio encoder HE-AAC provides high quality stereo sound at 32 kbit/s and video encoders H.264/AVC, H.265/HEVC provide high quality video with standard TV definition and 25 fps frame rate at bitrate about 500 kbit/s.

Physical layer and other used elements of lower protocol layers of Open System Interconnection (OSI) are defined in RAVIS transmission system.

Main components of application layer are real-time audio and audio visual applications and some supplementary services such as Electronic Programme Guide etc. Presentation layer includes source encoding. Multiplexing of audio, video and supplementary data is performed at link layer using MPEG-2 transport stream or RAVIS transport container.

Example of protocol stack for RAVIS system is illustrated on Fig. 56.

FIGURE 56  
RAVIS protocol stack

Application layer	Real-time audio and video application	Electronic programme guide
Presentation layer	H.264/MPEG-4 AVC, H.265/MPEG-H HEVC (video) HE-AAC (audio)	XML, HTML, JSON
Link layer	Transport stream MPEG-2 TS, Transport container RAVIS TC	
Physical layer	Physical layer RAVIS (BCH, LDPC, M-QAM, OFDM)	

BS.1114-56

### 3 Key technologies

The system provides three logical data transmission channels. Apart from the Main Service Channel, RAVIS provides data channels with enhanced transmission reliability – Low Bitrate Channel (~12 kbit/s) and Reliable Data Channel (~5 kbit/s). These additional channels may be used, for example, for emergency alerting, etc.

The RAVIS system allows various levels of QAM modulation and various rates of channel coding in the main service channel, which are used to achieve an optimal balance between bitrate and reliability (interference protection).

The main service channel is designed for video and audio data transmission. Maximum bitrate in this logical channel is about 900 kbit/s. Low bit-rate channel is designed for transmission of information with increased reliability, for emergency voice alerting, for example. Bit rate is about 12 kbit/s. Reliable data channel is designed for auxiliary data with high reliability. Bit rate is about 5 kbit/s. The low bit-rate channel and reliable data channel provide higher interference protection and consequently larger coverage and higher stability of reception compared to main service channel.

Digital data bitrates in a single radio channel for all combinations of modulation parameters and FEC rates are given in Table 48.

TABLE 48

#### Digital data bit rates in RAVIS system

Constellation	FEC rate	Data stream bit rate (kbit/s)		
		100 kHz channel	200 kHz channel	250 kHz channel
QPSK	1/2	80	160	200
	2/3	100	210	270
	3/4	120	240	300
16-QAM	1/2	150	320	400
	2/3	210	420	530
	3/4	230	470	600
64-QAM	1/2	230	470	600
	2/3	310	630	800
	3/4	350	710	900

Main service channel may use QPSK, 16-QAM or 64-QAM modulation, and FEC coding rates of  $R = 1/2$ ,  $2/3$  or  $3/4$ . Low bit-rate channel uses QPSK modulation, and FEC coding rate of  $R = 1/2$ . Reliable data channel uses BPSK modulation and FEC coding rate  $R = 1/2$ .

Pilot carriers and carriers with signal transmission parameters (service carriers) are inserted into multiplexed stream of OFDM symbols. These carriers provide synchronization, channel distortion correction and transmission of additional information (including the parameters of modulation and channel coding, availability of logical data channels, etc.) for the reception side.

Peak-to-average power ratio reduction is not mandatory but recommended.

Figure 57 shows the functional block diagram of the transmission part of RAVIS, and Fig. 58 shows the functional block diagram of a RAVIS receiver.

FIGURE 57

The RAVIS transmitter functional block diagram

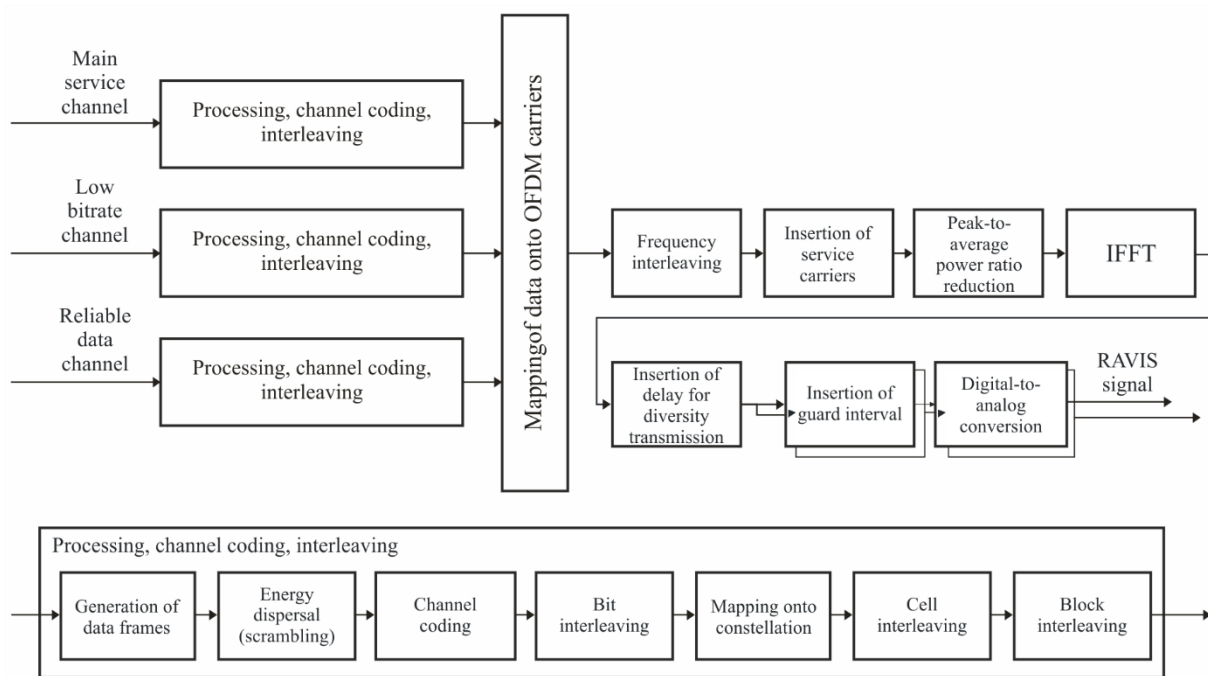

BS.1114-57



FIGURE 58

The RAVIS receiver functional block diagram

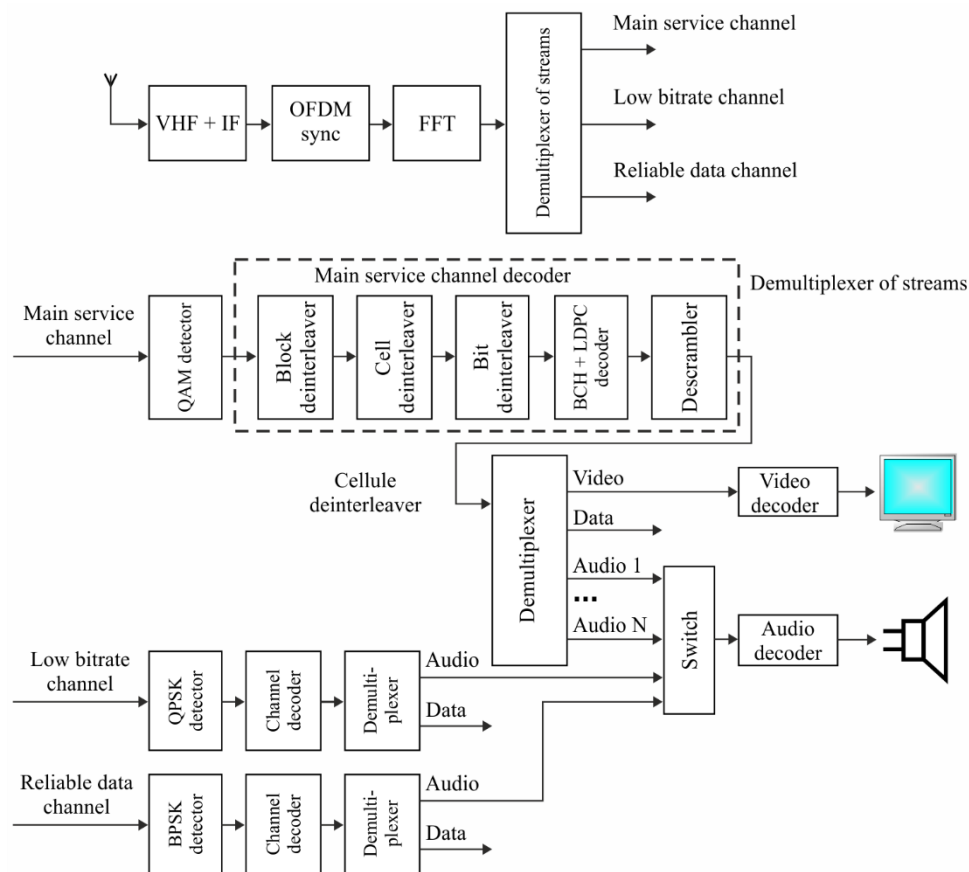

BS.1114-58

The selected frequency band and the selected broadcasting concept have some advantages:

- possibility of utilization of single-frequency network and multi-frequency network;
- broadcasting of multiple high-quality stereo sound programmes or a video stream with a stereo sound accompaniment in a city using only one transmitter;
- ability to localize broadcasting of single programme, i.e. the same frequency is used to broadcast different programmes in various cities.

#### 4 Physical and link layers

At physical layer the channel coding and OFDM modulation scheme in RAVIS are defined as a functional block for adaptation of data from source encoder to transmission channel characteristics. Data streams from all logical channels are subject of the following transformations:

- data frame generation;
- data frame energy dispersal;
- outer coding (BCH block code);
- inner coding (LDPC block code);
- bit interleaving;
- mapping of bits onto cells of modulation constellation;
- cell interleaving;
- block interleaving;

- mapping of logical channels data onto OFDM cells;
- frequency interleaving and insertion of service carriers;
- peak-to-average power ratio reduction;
- IFFT;
- guard interval insertion, full OFDM signal generation.

At link layer encoded source data may be multiplexed using various formats, including fixed length packets (particularly MPEG-2 TS) and variable length packets (particularly GSE or RAVIS transport container), or non-structured data stream.

## 5 Performance of system

Fixed, portable and mobile reception modes of RAVIS signal were simulated using channel models from ETSI ES 201 980 (Annex B.2) to evaluate minimum required carrier-to-noise ratio  $(C/N)_{min}$  (for  $BER = 10^{-4}$  after channel decoder) for various modulation types and coding rates of main service channel. Channel 7 (AWGN) models fixed reception mode, channel 8 (Urban) models portable reception mode, channel 11 (Hilly terrain) models mobile reception mode. Table 49 shows these results for 250 kHz channel bandwidth.

TABLE 49

$(C/N)_{min}$  values for RAVIS with 250 kHz channel bandwidth, main service channel

Channel model/ reception mode	$(C/N)_{min}$ (dB)								
	QPSK			16-QAM			64-QAM		
	R = 1/2	R = 2/3	R = 3/4	R = 1/2	R = 2/3	R = 3/4	R = 1/2	R = 2/3	R = 3/4
Channel 7 (AWGN)/fixed reception	1.1	3.3	4.2	6.4	9.1	10.2	10.8	14.0	15.4
Channel 8 (urban)/portable reception	6.4	9.4	11.5	12.5	14.9	17.0	16.2	19.4	22.0
Channel 11 (hilly terrain)/mobile reception	5.5	8.6	9.8	10.4	13.2	15.6	14.7	17.9	20.5

## 6 Summary of system parameters

Table 50 defines characteristics of RAVIS system.

TABLE 50

## Key characteristics of RAVIS system

Characteristics	RAVIS
Reception modes: – Fixed – Portable – Portable handheld – Mobile	+ + + +
Net data rates	Depending on modulation and code rate for different channel bandwidth: a) 100 kHz-75-341 kbit/s b) 200 kHz-155-703 kbit/s c) 250 kHz-196-888 kbit/s
Spectrum efficiency (bit/s/Hz)	0.77-3.64
Single frequency networks	Supported
Broadcasting types: – sound – multimedia – TV	+ +
Transmission data/service types	Video, audio, still pictures, presentations, traffic data, etc.
Frequency bands	VHF bands I, II
Channel bandwidth	a) 100 kHz b) 200 kHz c) 250 kHz
Used bandwidth	a) 96.0 kHz b) 185.6 kHz c) 246.2 kHz
Number of segments	1
Number of subcarriers per segment	a) 215 b) 439 c) 553
Subcarrier spacing	4000/9 Hz
Active symbol duration	2.25 ms
Guard interval duration/ ratio	1/8
Frame duration	103.78125 ms (41 OFDM symbols)
Time/frequency synchronization	Guard interval/ Pilot carriers
Modulation methods	QPSK, 16-QAM, 64-QAM
Inner FEC	LDPC code with approximate code rates 1/2, 2/3, 3/4
Inner interleaving	Bit, cell, time and frequency interleaving
Outer FEC	BCH (n, k, t); n, k depend on channel bandwidth, LDPC code rate; error correction capability t = 10 errors (for main service channel)
Outer interleaving	–
Data randomization/ energy dispersal	16 bit PRBS
Hierarchical transmission	–
Transmission parameter signalling	Four subcarriers per OFDM symbol, 41 bit per OFDM frame