



Recommendation ITU-R BO.1784-1
(12/2016)

**Digital satellite broadcasting system with
flexible configuration
(television, sound and data)**

BO Series
Satellite delivery

Foreword

The role of the Radiocommunication Sector is to ensure the rational, equitable, efficient and economical use of the radio-frequency spectrum by all radiocommunication services, including satellite services, and carry out studies without limit of frequency range on the basis of which Recommendations are adopted.

The regulatory and policy functions of the Radiocommunication Sector are performed by World and Regional Radiocommunication Conferences and Radiocommunication Assemblies supported by Study Groups.

Policy on Intellectual Property Right (IPR)

ITU-R policy on IPR is described in the Common Patent Policy for ITU-T/ITU-R/ISO/IEC referenced in Annex 1 of Resolution ITU-R 1. Forms to be used for the submission of patent statements and licensing declarations by patent holders are available from <http://www.itu.int/ITU-R/go/patents/en> where the Guidelines for Implementation of the Common Patent Policy for ITU-T/ITU-R/ISO/IEC and the ITU-R patent information database can also be found.

Series of ITU-R Recommendations

(Also available online at <http://www.itu.int/publ/R-REC/en>)

Series	Title
BO	Satellite delivery
BR	Recording for production, archival and play-out; film for television
BS	Broadcasting service (sound)
BT	Broadcasting service (television)
F	Fixed service
M	Mobile, radiodetermination, amateur and related satellite services
P	Radiowave propagation
RA	Radio astronomy
RS	Remote sensing systems
S	Fixed-satellite service
SA	Space applications and meteorology
SF	Frequency sharing and coordination between fixed-satellite and fixed service systems
SM	Spectrum management
SNG	Satellite news gathering
TF	Time signals and frequency standards emissions
V	Vocabulary and related subjects

Note: This ITU-R Recommendation was approved in English under the procedure detailed in Resolution ITU-R 1.

Electronic Publication
Geneva, 2017

© ITU 2017

All rights reserved. No part of this publication may be reproduced, by any means whatsoever, without written permission of ITU.

RECOMMENDATION ITU-R BO.1784-1

**Digital satellite broadcasting system with flexible configuration
(television, sound and data)**

(Question ITU-R 285/4)

(2007-2016)

Scope

This Recommendation is intended for the digital broadcasting-satellite service (BSS), when high flexibility in the system configuration and broadcasting interactivity is of importance allowing for a wide-ranging trade-off between operation under minimal C/N levels or maximum transmission capacity.

Keywords

HDTV, UHD TV, satellite, broadcasting, channel bonding, DVB-S2, DVB-S2X

Abbreviations/Glossary

AAC	Advanced Audio Coding
ACM	Adaptive Coding and Modulation
ALS	Audio Lossless coding
APSK	Amplitude and Phase Shift Keying
ATM	Asynchronous Transfer Mode
AVC	Advanced Video Coding
AWGN	Additive White Gaussian Noise
BB	BaseBand
BCH code	Bose-Chaudhuri-Hocquenghem code
BPSK	Binary Phase Shift Keying
BSS	Broadcasting-Satellite Service
CCM	Constant Coding and Modulation
C/N	Carrier to Noise Ratio
CRC	Cyclic Redundancy Check
DSNG	Digital Satellite News Gathering
DTH	Direct To Home
DVB	Digital Video Broadcasting project
DVB S	DVB System for satellite broadcasting
DVB S2	Second generation DVB System for satellite broadcasting and unicasting
DVB S2X	Extensions of the second generation DVB System for satellite broadcasting and unicasting
FEC	Forward Error Correction

FPGA	Field Programmable Gate Array
GF	Galois Field
GS	Generic Stream
GSE	Generic Stream Encapsulation
HDTV	High Definition Television
HEVC	High Efficiency Video Coding
IBO	Input Back Off
IP	Internet Protocol
IRD	Integrated Receiver Decoder
LDPC	Low Density Parity Check
LNB	Low Noise Block
MPEG	Moving Picture Experts Group
OBO	Output Back Off
PL	Physical Layer
PSK	Phase Shift Keying
PRBS	Pseudo-Random Binary Sequence
QAM	Quadrature Amplitude Modulation
QEF	Quasi Error Free
QPSK	Quadrature Phase Shift Keying
RF	Radio Frequency
RS	Reed Solomon
SDTV	Standard Definition Television
SNR	Signal to Noise Ratio
SOF	Start of Frame
TS	Transport Stream
TV	Television
TWTA	Traveling Wave Tube Amplifier
UHDTV	Ultra-High Definition Television
VCM	Variable Coding and Modulation
VL-SNR	Very Low - Signal to Noise Ratio
VSAT	Very Small Aperture Terminal

Related ITU Recommendations, Reports

Recommendation ITU R BO.1408-1	Transmission system for advanced multimedia services provided by integrated services digital broadcasting in a broadcasting-satellite channel
Recommendation ITU R BO.1516-1	Digital multiprogramme television systems for use by satellites operating in the 11/12 GHz frequency range

The ITU Radiocommunication Assembly,

considering

- a) that the digital multiprogramme television systems for use by satellites have been developed in Recommendations ITU-R BO.1408 and ITU-R BO.1516, which are referred to as the current systems;
- b) that recent developments in the field of channel coding and modulation have produced new techniques with performances approaching the Shannon limit;
- c) that these new digital techniques would offer better spectrum and/or power efficiency, in comparison to the current systems, whilst maintaining the possibility to be flexibly configured to cope with the specific satellite bandwidth and power resources;
- d) that the recommended system makes use of such techniques and thus allows for a wide-ranging trade-off between operation under minimal C/N levels or maximum transmission capacity, achieving appreciable gain over DVB-S (System A in Recommendation ITU-R BO.1516) depending on the selected DVB-S2 mode;
- e) that the recommended system was developed to cover not only broadcasting, but also interactivity and contribution applications, such as contribution TV links and digital satellite news gathering (DSNG);
- f) that a system covering all these application areas while keeping the single-chip decoder at reasonable complexity levels, would enable the reuse of the development for the mass market products for contribution or niche applications;
- g) that the new adaptive coding and modulation (ACM) technique offered by the recommended system would allow a more efficient spectrum utilization for unicast applications in connection with a return path, through the optimization of the transmission parameters (i.e. modulation and coding) for each individual user, dependent on path conditions;
- h) that the recommended system accommodates any input stream format, including single or multiple Motion Picture Experts Group (MPEG) Transport Streams (characterized by 188-byte packets), IP as well as asynchronous transfer mode (ATM) packets and continuous bit-streams;
- i) that the recommended system would be capable to handle the variety of advanced audiovisual formats currently available and under definition;
- j) that new extensions to the recommended system offers improved performance and features for its core applications, including Direct to Home (DTH) broadcasting of Ultra-High Definition Television (UHDTV), and also provides an extended operational range to cover emerging markets such as mobile applications,

further considering

- a) that an ITU system Recommendation helps the market in establishing services based on standardized systems, thus avoiding the proliferation of proprietary developments, which is of benefit to both the end users and the industry in general;
- b) that, in spite of the success of the current systems, a new specification to enable delivery of a significantly higher data rate in a given transponder bandwidth than the current systems are able to do, is appreciated by many satellite broadcasters, operators and manufacturers around the world;
- c) that the requirement to offer high-definition television (HDTV) and UHDTV services will force broadcasters to look for more efficient methods of carrying these services within the existing transponders;

d) that the inherent flexibility of the recommended system and of its extensions would provide means to alleviate the influence of the atmospheric attenuations at the higher broadcasting-satellite service (BSS) bands, which are intended to be used for HDTV services and beyond,

recommends

1 that the DVB-S2 system specified in ETSI EN 302 307-1 V 1.4.1 (see Attachment 1) may be considered as a suitable system for the development of a system for satellite broadcasting with flexible configuration;¹

2 that the DVB-S2X system specified in ETSI EN 302 307-2 V1.1.1 (see Attachment 2) may be considered as a suitable system for the development of a system for satellite broadcasting with improved performance and features.¹

NOTE 1 – A description of the recommended system DVB-S2 (System E1) is provided in Annex 1, a description of the extensions DVB-S2X to the recommended system (System E2) is provided in Annex 2, while Annex 3 contains comparison tables which list the recommended systems (Systems E1 and E2) along with the systems contained in Recommendation ITU-R BO.1516 (Systems A, B, C, D).

Annex 1

Main characteristics of the DVB-S2 system (referred to as System E1)

DVB-S2 is the second-generation specification for satellite broadband applications developed by the DVB (Digital Video Broadcasting) Project in 2003 and became ETSI standard EN 302 307 in 2004.

EN 302 307 specifies framing structure, channel coding and modulation for different types of satellite applications:

- broadcasting of standard definition and high-definition TV (SDTV and HDTV);
- interactivity (including Internet access) for satellite broadcasting applications (for integrated receivers-decoders (IRDs) and personal computers);
- contribution applications, such as digital TV contribution, distribution and news gathering;
- data content distribution and internet trunking.

To be able to cover all the application areas while still keeping the single-chip decoder at reasonable complexity levels, DVB-S2 is structured as a *tool-kit*, thus enabling the use of mass market products also for contribution or niche applications.

The DVB-S2 system has been specified around three concepts: best transmission performance, approaching Shannon limit, total flexibility and reasonable receiver complexity.

To achieve the best performance-complexity trade-off, achieving an appreciable capacity gain over DVB-S for conventional broadcast applications, DVB-S2 benefits from more recent developments in channel coding and modulation: low-density parity check (LDPC) codes are adopted combined with quadrature phase shift keying (QPSK), 8-PSK, 16-APSK (amplitude and phase shift keying) and 32-APSK modulations, for the system to properly work on the non-linear satellite channel.

¹ The word “shall” in this ETSI standard should be considered as “should” in this ITU-R Recommendation.

Framing structure allows maximum flexibility for a versatile system and synchronization also in worst-case configurations (low signal-to-noise ratios, SNR).

For interactive point-to-point applications such as IP unicasting in connection with a return path, the adoption of the ACM functionality allows to optimize the transmission parameters for each individual user on a frame-by-frame basis, dependant on path conditions, under closed-loop control via the return channel (connecting the receiver to the DVB-S2 uplink station via terrestrial or satellite links, signalling the receiver reception condition). This results in a further increase of the spectrum utilization efficiency of DVB-S2 over DVB-S, allowing the optimization of the space segment design, thus making possible a drastic reduction of the cost of satellite-based IP services.

DVB-S2 is so flexible that it can cope with any existing satellite transponder characteristics, with a large variety of spectrum efficiencies and associated SNR requirements. Furthermore it is designed to handle the variety of advanced audio-video formats currently under definition by the international bodies. DVB-S2 accommodates any input stream format, including single or multiple MPEG Transport Streams (characterized by 188-byte packets), IP as well as ATM packets and continuous bit-streams.

The DVB-S2 system structure

The DVB-S2 system is composed of a sequence of functional blocks, as described in Fig. 1. Signal generation is based on two levels of framing structures:

- BBFRAME at baseband (BB) level, carrying a variety of signalling bits, to configure the receiver flexibly according to the application scenario;
- PLFRAME at physical layer (PL) level, carrying few highly-protected signalling bits, to provide robust synchronization and signalling at the physical layer.

FIGURE 1
Functional block diagram of the DVB-S2 system

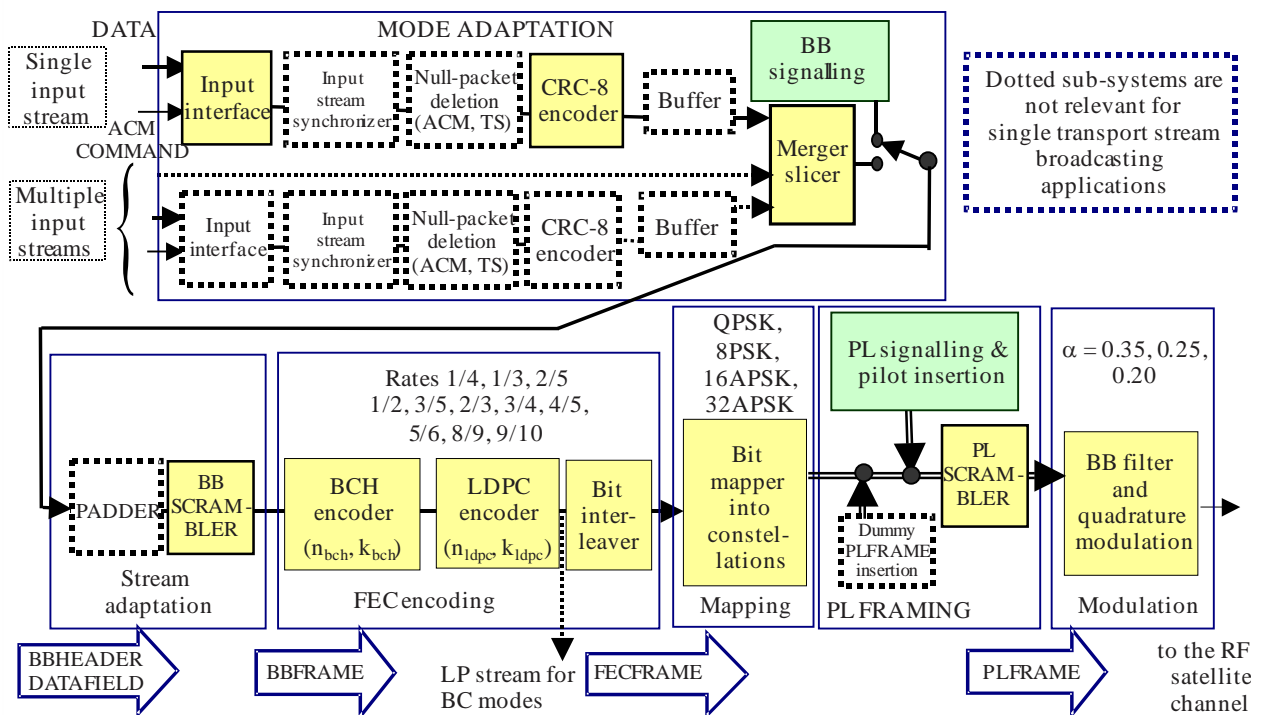

Depending on the application, DVB-S2 input sequences may be single or multiple MPEG transport streams (TS), single or multiple generic streams, either packetized or continuous. The block identified as *Mode Adaptation* provides input stream interfacing², input stream synchronization³ (optional), null-packet deletion⁴ (for ACM and transport stream input format only), CRC-8 coding for error detection at packet level in the receiver (for packetized input streams only), merging of input streams (for multiple input stream modes only) and slicing into data fields. A baseband header is then appended in front of the data field, to notify the receiver of the input stream format and Mode Adaptation type to notify the receiver of the input stream format and Mode Adaptation type: single or multiple input streams, generic or transport stream, constant coding and modulation (CCM) or ACM, and many other configuration details. Thanks to the forward error correction (FEC) protection (covering both the header and the data payload) and the wide length of the FEC frame, the baseband header can in fact contain many signalling bits without losing transmission efficiency or ruggedness against noise. It should be noted that the MPEG multiplex transport packets may be asynchronously mapped to the baseband frames.

Stream Adaptation is then applied, to provide padding in case the user data available for transmission are not sufficient to completely fill a BBFRAME, and baseband scrambling.

Forward error correction (FEC) encoding carries out the concatenation of BCH (Bose-Chaudhuri-Hochquenghem) outer code and low density parity check (LDPC) inner codes (rates 1/4, 1/3, 2/5, 1/2, 3/5, 2/3, 3/4, 4/5, 5/6, 8/9, 9/10). Depending on the application area, the FEC coded blocks (FEC frames) can have a length of 64 800 or 16 200 bits. When variable coding and modulation (VCM) or ACM are used, FEC and modulation mode are constant within a frame but may be changed in different frames; furthermore, the transmitted signal can contain a mix of normal and short code blocks.

Mapping can be chosen among QPSK, 8-PSK, 16-APSK and 32-APSK constellations (see Fig. 2), depending on the application area. QPSK and 8-PSK are typically proposed for broadcast applications, since they are virtually constant envelope modulations and can be used in non-linear satellite transponders driven near saturation. The 16-APSK and 32-APSK modes, mainly targeted to contribution applications, can also be used for broadcasting, but these require a higher level of available C/N and the adoption of advanced pre-distortion methods in the uplink station to minimize the effect of transponder non-linearity. Whilst these modes are not as power efficient as the other modes, the spectrum efficiency is much greater. The 16-APSK and 32-APSK constellations have been optimized to operate over a non-linear transponder by placing the points on circles. Nevertheless their performances on a linear channel are comparable with those of 16-QAM and 32-QAM respectively.

By selecting the modulation constellation and code rates, spectrum efficiencies from 0.5 to 4.5 bits per symbol are available and can be chosen dependant on the capabilities and restrictions of the satellite transponder used.

² Input sequences may be single or multiple TSs, single or multiple generic streams (packetized or continuous).

³ Data processing in DVB-S2 may produce variable transmission delay. This block allows to guarantee constant-bit-rate and constant end-to-end transmission delay for packetized input stream.

⁴ To reduce the information rate and increase the error protection in the modulator. The process allows null-packets reinsertion in the receiver in the exact place where they originally were.

FIGURE 2
The four possible DVB-S2 constellations before physical layer scrambling

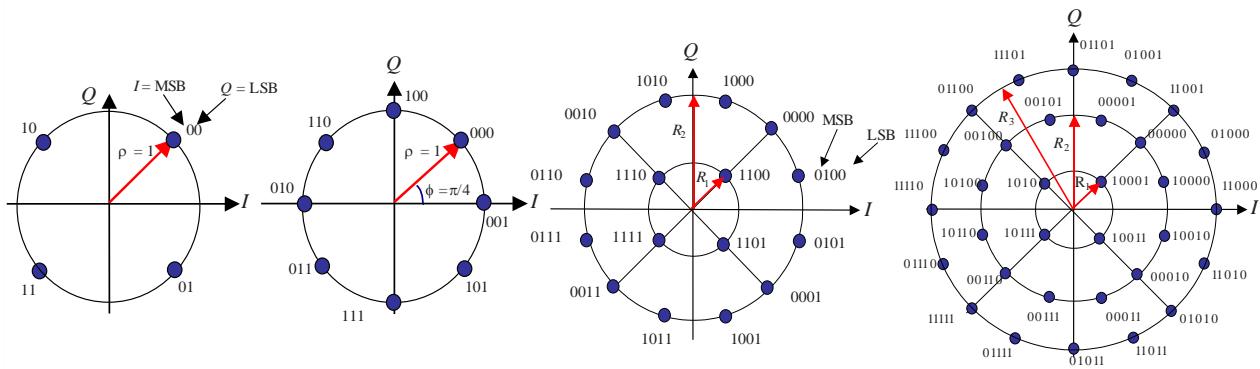

BO.1784-02

Physical layer framing has been designed to provide robust synchronization and signalling at the physical layer. Thus a receiver may synchronize (carrier and phase recovery, frame synchronization) and detect the modulation and coding parameters before demodulation and FEC decoding. The DVB-S2 physical layer signal is composed of a regular sequence of frames (see Fig. 3): within a frame, the modulation and coding scheme is homogeneous, but may change (in the adaptive coding and modulation configuration) in adjacent frames. Every frame is composed of a payload of 64 800 bits in the “normal frame” configuration, 16 200 bits in the “short frame” one, corresponding to an FEC code block. A header of 90 binary modulation symbols precedes the payload, containing synchronization and signalling information, to allow a receiver to synchronize (carrier and phase recovery, frame synchronization) and detect the modulation and coding parameters before demodulation and FEC decoding.

FIGURE 3
PL frame scheme

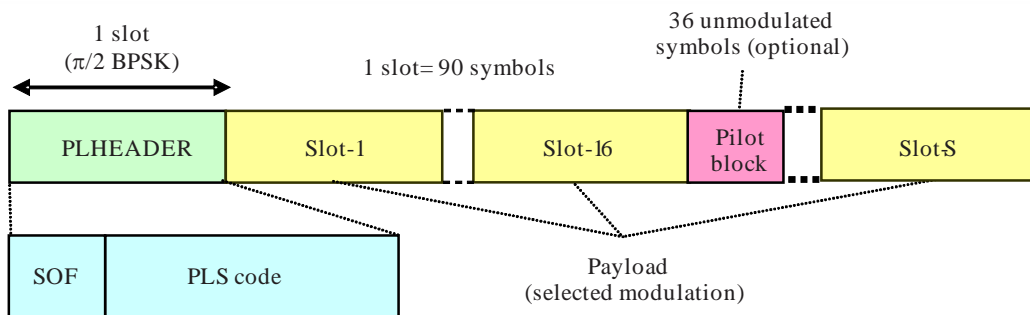

BO.1784-03

The first 26 binary symbols (the sequence 18D2E82_{HEX}) of the PL header identify the start of the PL frame (SOF, Start Of Frame), the remaining 64 symbols are used for signalling the system configuration. Since the PL header is the first entity to be decoded by the receiver, it could not be protected by the FEC scheme (i.e. BCH and LDPC). On the other hand, it had to be perfectly decodable under the worst-case link conditions (SNR of about -2.5 dB). Therefore, to minimally affect the global spectrum efficiency, the signalling information at this level has been reduced to 7 bits, 5 of which are used to indicate the modulation and coding configuration (MODCOD field), 1 for frame length (64 800 or 16 200 bits), 1 for presence/absence of pilots to facilitate receiver synchronization (as explained below). These bits are then highly protected by an interleaved first-order Reed-Muller block code with parameter rates (64, 7, $t = 32$), suitable for soft-decision correlation decoding.

Independently from the modulation scheme of the PLFRAME payload (FEC code block), the 90 binary symbols forming the PL header are $\pi/2$ -BPSK modulated; this variant of the classical BPSK constellation introduces a $\pi/4$ rotation on even symbols and $-\pi/4$ on odd symbols, thus allowing a reduction of the radio-frequency signal envelope fluctuations.

The PL frame payload is composed of a different number of modulated symbols depending on the FEC length (64 800 or 16 200 bits) and the modulation constellation, but (excluding the optional pilots) the payload length is always a multiple of a slot of 90 symbols (see Fig. 3), thus showing periodicities which can be exploited by the frame synchronizer in the receiver: once the current PL header has been decoded, the decoder knows exactly the PL frame length and thus the position of the following SOF.

PL framing also provides for:

- optional dummy PL frame insertion, when no useful data is ready to be sent on the channel, and
- the insertion of optional pilots to facilitate receiver synchronization.

The DVB-S2 FEC codes are in fact so powerful that carrier recovery may become a serious problem for high-order modulations working at low SNRs in the presence of high levels of phase noise in satellite broadcasting low noise block (LNB) converters and tuners: this is particularly the case with some low-rate 8-PSK, 16-APSK and 32-APSK modes of DVB-S2. Pilots are unmodulated symbols, identified by $I = Q = 1/\sqrt{2}$, grouped in blocks of 36 symbols and inserted every 16 payload slots, thus giving a maximum capacity loss of approximately 2.4% when used.

Finally, scrambling for energy dispersal is carried out to comply with the Radio Regulations for spectrum occupancy and to transmit a sort of “signature” of the service operator, for a rapid identification in case of errors in the uplink procedures.

Baseband filtering and quadrature modulation is then applied, to shape the signal spectrum and to generate the RF signal. Square-root raised cosine filtering is used at the transmit side, with a choice of three roll-off factors: 0.35, 0.25 and 0.20, depending on the bandwidth restrictions.

Attachment 1 to Annex 1

Laboratory test results on DVB-S2 equipment

In order to verify the performance of DVB-S2, extensive laboratory tests have been carried out by Rai-CRIT on DVB-S2 equipment provided by seven different manufacturers in June 2006. The tests included AWGN performance, non-linear channel and phase noise degradation. The results clearly indicate that the equipment performance is in line with the simulation results presented in the DVB-S2 standard.

Single carrier and multicarrier configuration have been implemented and compared to DVB-S equivalent configurations, showing that DVB-S2 can offer excellent gains both in terms of capacity or performance and in terms of flexibility. Furthermore VCM and ACM configurations have been implemented, and the equipment capability verified.

Finally, it is to be noted that the equipment under test showed excellent interoperability performance.

1 Main test results

AWGN test

Measurements have been carried out on the AWGN channel respectively for QPSK, 8-PSK, 16-APSK and 32-APSK to assess the system performance both for the normal and for the short FECFRAME configuration. The symbol rate was of 27.5 MBd, except for 32-APSK where it was 20 MBd⁵, and the roll-off 35%. The average results obtained in the measurements show that implementation losses, calculated as the $\Delta E_s/N_0 @ PER = 10^{-7}$ with respect to the simulation results indicated in Table 13 of EN 302 307, are in the range of 0.2 to 0.6 dB for QPSK, 0.2 to 0.9 dB for 8-PSK, 0.3 to 1.3 dB for 16-APSK, and 1.3 to 1.7 dB for 32-APSK.

SAT test

On the non-linear satellite channel, the laboratory test results confirm the simulation results as reported in Table H.1 of EN 302 307. The optimum operating point is 0 dB input back-off (IBO) for QPSK1/2, corresponding to an output back-off (OBO) of 0.3 dB, and giving a performance degradation of about 0.5 dB with respect to the AWGN channel. For 8-PSK the optimum operating point is 1 dB IBO, corresponding to an OBO of 0.4 dB, and giving a performance degradation of about 0.6 dB. For 16-APSK the optimum operating point is 4 dB IBO, corresponding to an OBO of 1.6 dB, and giving a performance degradation of about 3.0 dB. For 32-APSK the optimum operating point is 7 dB IBO, corresponding to an OBO of 3.2 dB, and giving a performance degradation of about 5.4 dB. If pilots are inserted in the transmitted signal, the performance improves by about 0.3 dB for 8-PSK and 1.0 dB for 16-APSK.

Additional tests have been carried out using signal precorrection in the modulator to reduce the non-linear effects on the demodulated signal and allow the system to work closer to the saturation point, also for higher order modulations, i.e. 16- and 32-APSK. For 16-APSK rate 3/4, the use of precorrection in the modulator allows the system to operate optimally at saturation, with a decrease of the satellite OBO of about 1.3 dB and a performance loss with respect to AWGN channel of about 1.5 dB, i.e. allowing a gain in performance with respect to the non-precorrected signal of about 1.5 dB.

Comparative examples of DVB-S and DVB-S2 for broadcast applications have been investigated, according to the following configurations:

TABLE 1
Comparative DVB-S/DVB-S2 scenarios for broadcast applications

System	DVB-S	DVB-S2	DVB-S	DVB-S2
Channel bandwidth BW (MHz)	36	36	36	36
Modulation and coding	QPSK 2/3	QPSK 3/4	QPSK 7/8	8-PSK 2/3
Roll-off α	0.35	0.20	0.35	0.25
Symbol-rate (MBd) = $1.03 \cdot BW / (1 + \alpha)$	27.5	30.9	27.5	29.7
C/N (in 27.5 MHz) (dB)	4.7	4.9	7.6	7.6
Useful bit-rate (Mbit/s)	33.8	46 (gain = 34%)	44.4	58.8 (gain = 32%)

⁵ Maximum symbol rate available for the 32-APSK configuration. Above 20 MBd, the equipment performance is for the time being not guaranteed, since the clock speed and/or the FPGA density do not allow to perform the required number of LDPC decoder iterations. It can be expected that improvements of FPGA technology could in the near future allow to cover at full performance extreme baud rates.

The satellite channel includes the travelling wave tube amplifier (TWTA) and output multiplex (OMUX) filter.

The results in Table 1 indicate that at the expense of a marginal increase of the C/N requirements (0 to 0.2 dB), the DVB-S2 system allows to increase the transmitted capacity dependent upon the mode, to up to and beyond 30%.

Phase noise test

Two different configurations have been considered for the phase noise tests:

- A contribution scenario, with a symbol rate of the transmitted signal of 5 MBd and the satellite amplifier operating in linearity.
- A satellite broadcasting scenario, with a symbol rate of the transmitted signal of 27.5 MBd and the satellite amplifier operating at the optimum back-off.

Results obtained for the contribution scenario indicate that the degradation introduced by the LNB phase noise is in the order of 0.3 dB for QPSK and 8-PSK, 1.2 dB for 16-APSK and 32-APSK. Furthermore pilots are not required for QPSK, while they start to be beneficial for 8-PSK; 16-APSK and 32-APSK need pilots to give good results.

The satellite broadcasting type scenario, with a larger symbol rate, is instead much less critical with respect to phase noise. The results indicate that the degradation introduced by the LNB phase noise is negligible for QPSK even without pilots, in the order of 0.1 dB for 8-PSK and 0.3 dB for 16-APSK with the use of pilots.

VCM and ACM tests

VCM tests have been carried out, demonstrating the receivers' capability to adapt to the change of the transmission configuration. A sequence of FECFRAMES has been generated and stored on an arbitrary waveform generator. Noise was then inserted to give different values of signal-to-noise ratio. Provided that the signal-to-noise ratio was larger than the minimum requested by a specific modulation and coding, the receiver was able to decode the corresponding FEC frame.

Finally ACM functionality was tested, to investigate the receivers' capability to estimate the experienced signal-to-noise ratio, and the corresponding adaptivity of the modulator to change the modulation and coding. The results show that in a point-to-point connection the equipment is able to follow the signal-to-noise ratio variations and to adapt correspondingly.

2 Conclusions

The tests carried out at Rai-CRIT laboratories demonstrate that the DVB-S2 equipment is in line with the performance predicted by computer simulations, and allow to gain an important insight on the characteristics of the sophisticated modulation, channel coding, framing and synchronization techniques of the DVB-S2 system. In spite of the fact that the equipment being tested represents a first generation of equipment, and consequently some improvement of the receiver algorithms is certainly expected which will offer further enhancement in the performance, as an average, the results indicate that DVB-S2 is an excellent system, not only on paper, but also in the real hardware.

Furthermore, comparison with the performance of DVB-S in operative configurations, indicates that DVB-S2 offers an appreciable gain in capacity in CCM configurations both in single carrier and in multiple carrier per transponder configuration.

Finally, tests have been carried out by coupling modulators and demodulators of different manufacturers with the results that the equipment shows excellent interoperability.

Annex 2

Main characteristics of the DVB-S2X system (broadcasting part is referred to as System E2)

DVB-S2X is an extension of the DVB-S2 specification for satellite broadband applications and provides additional technologies and features. DVB-S2X is published as ETSI EN 302 307 part 2, with DVB-S2 being part 1.

DVB-S2X offers improved performance and features for the core applications of DVB-S2, including Direct to Home (DTH), contribution, VSAT and DSNG. The specification also provides an extended operational range to cover emerging markets such as mobile applications.

DVB-S2 has been specified about 10 years ago with a strong focus on DTH. Since then, new requirements have come up and DVB-S2X provides the necessary technical specifications. DVB-S2X supports significantly higher spectral efficiency for the Carrier to Noise Ratios (C/N) typical for professional applications such as contribution links or IP-trunking. It also supports very low C/N down to -10 dB for mobile applications (e.g. maritime, aeronautical, trains, etc.).

DVB-S2X is based on the well-established DVB-S2 specification. It uses the proven and powerful LDPC Forward Error Correction (FEC) scheme in combination with BCH FEC as outer code and introduces the following additional elements:

- Smaller roll-off options of 5% and 10% (in addition to 20%, 25% and 35% in DVB-S2).
- A finer gradation and extension of number of modulation and coding modes.
- New constellation options for linear and non-linear channels (constellations for linear channels are indicated as xxx-L, where xxx is the corresponding non-linear constellation).
- Additional scrambling options for critical co-channel interference situations.
- Channel bonding over up to 3 channels.
- Very Low SNR operation support down to -10 dB SNR.
- Super-frame option.

This results in the following spectral efficiencies for DVB-S2X compared to DVB-S2 (Fig. 4).

FIGURE 4
Performance comparison of DVB-S2 and DVB-S2X

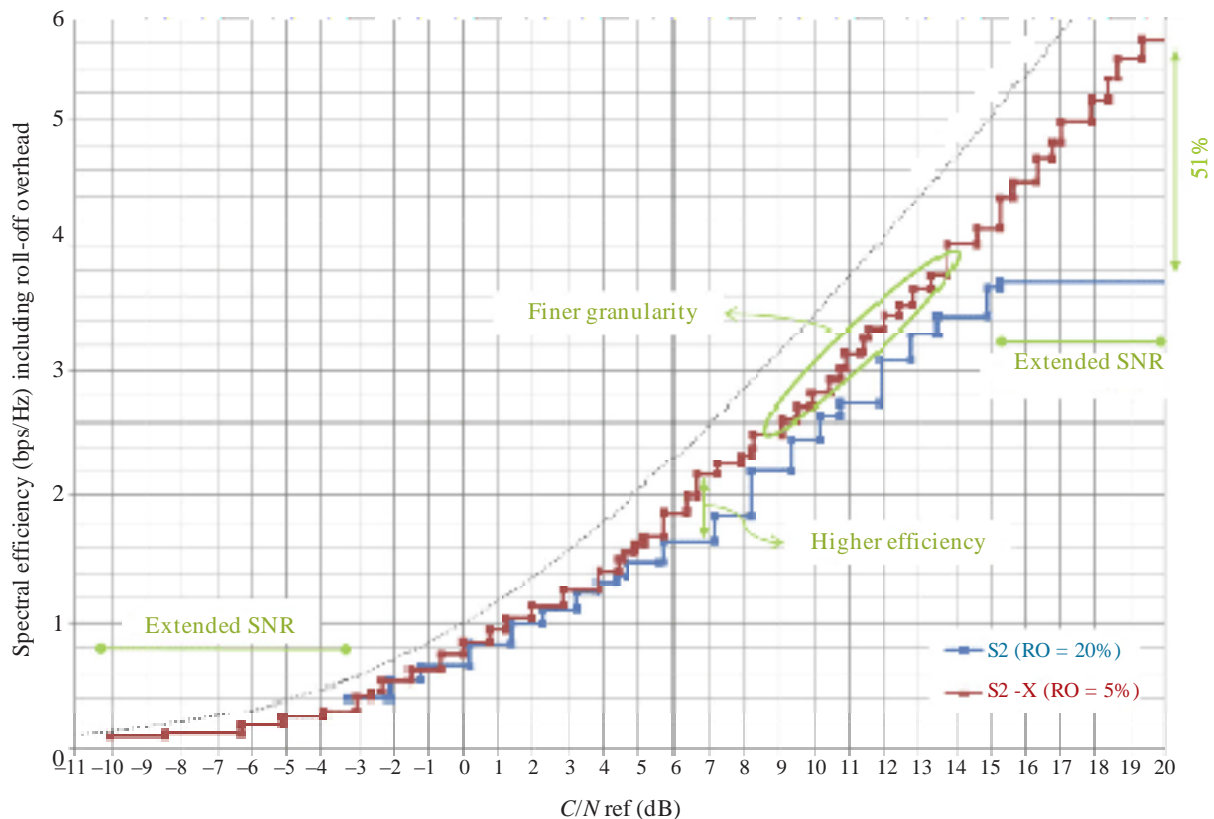

BO.1784-04

The usable C/N range is extended for values down to -10 dB by additional framing, coding and modulation options, which will enable satellite services for mobile (sea and air) and very small directive antennas. For VSAT applications the DVB-S2X specifications open up the possibility to support advanced techniques for future broadband interactive networks, i.e. intra-system interference mitigation, beam-hopping as well as multi-format transmissions. These may result in significant gains in capacity and flexibility of broadband interactive satellite networks and are made possible thanks to the optional Super-Framing structure.

DVB-S2 already offered excellent spectral efficiency for DTH applications and DVB-S2X therefore could not produce physical layer gains comparable to the transition from DVB-S to DVB-S2 (i.e. around 30%). Nevertheless, for DTH DVB-S2X fine-tunes both the physical and the upper protocol layers of DVB-S2, producing a highly attractive package (for new generation services, which would require new receivers in any case).

The most relevant features for DTH are channel bonding and finer granularity of modulation and FEC options combined with sharper roll-offs. Channel bonding of up to 3 satellite channels will support higher aggregate data rates and allow for additional statistical multiplexing gain for high data rate services such as UHD TV. The mandatory implementation of VCM (Variable Coding and Modulation) in receivers offers the possibility of increasing the spectral efficiency for UHD TV services, while guaranteeing service continuity during heavy rain by simulcasting highly protected Standard Definition (SD) components.

A finer granularity of modulation and FEC options allows for improved operational flexibility.

For professional and DSN applications high efficiency modulation schemes allow spectral efficiencies approaching 6 bit/s/Hz (with 256APSK). C/N values of up to 20 dB are now supported with an achievable gain improvement of up to 50%.

Annex 3

Comparison of the DVB-S2 system (System E1) and the DVB-S2X system (broadcasting part is referred to as System E2) with the system for digital multiprogramme television emissions by satellite defined in Recommendation ITU-R BO.1516

Table 2 includes information on both core functions (common elements) as well as additional essential functions for the four systems of Recommendation ITU-R BO.1516 (Systems A, B, C and D) and compares them with information regarding DVB-S2, indicated as System E1, and DVB-S2X, indicated as System E2.

The Radiocommunication Assembly, in § 6.1.2 of Resolution ITU-R 1, states that: “When Recommendations provide information on various systems relating to one particular radio application, they should be based on criteria relevant to the application, and should include, where possible, an evaluation of the recommended systems, using those criteria.” Table 3 provides this evaluation. Performance criteria relevant to these systems were selected, and the associated parametric values or capabilities of each of these systems are provided.

TABLE 2

Summary characteristics of digital broadband systems by satellite

a) Function

	System A	System B	System C	System D	System E1	System E2
Delivered services	SDTV and HDTV, sound, data and interactive data applications	SDTV and HDTV, sound, data and interactive data applications	SDTV and HDTV, sound, data and interactive data applications	SDTV and HDTV, sound, data and interactive data applications	SDTV, HDTV and UHDTV, sound, data and interactive data applications ⁽¹⁾	
Input signal format	MPEG-TS	Modified MPEG-TS	MPEG-TS	MPEG-TS	MPEG-TS/generic stream (e.g. IP)	
Multiple input signal capability	No	No	No	Yes, 8 maximum	Yes, 255 maximum	
Rain fade survivability	Determined by transmitter power and inner code rate	Determined by transmitter power and inner code rate	Determined by transmitter power and inner code rate	Hierarchical transmission is available in addition to the transmitter power and inner code rate	For broadcasting: determined by transmitter power and inner code rate. ⁽⁷⁾	For broadcasting: Variable Coding and Modulation is available in addition to transmitter power and inner code rate. ⁽⁷⁾
Channel bonding	No	No	No	No	No	Up to three channels
Mobile reception	Not available and for future consideration	Not available and for future consideration	Not available and for future consideration	Not available and for future consideration	Not available and for future consideration	VL-SNR modes suitable for mobile applications and other services to areas with SNR as low as -10 dB
Flexible assignment of services bit rate	Available	Available	Available	Available	Available	

TABLE 2 (continued)

a) Function (end)

	System A	System B	System C	System D	System E1	System E2
Common receiver design with other receiver systems	Systems A, B, C and D are possible	Systems A, B, C and D are possible	Systems A, B, C and D are possible	Systems A, B, C and D are possible	Systems A, B, C, D and E1 are possible	Systems A, B, C, D, E1 and E2 are possible
Commonality with other media (i.e. terrestrial, cable, etc.)	MPEG-TS basis	MPEG-ES (elementary stream) basis	MPEG-TS basis	MPEG-TS basis	MPEG-TS basis GSE, GSE-Lite basis	
Broadcasting station equipment	Available on the market	Available on the market	Available on the market	Available on the market	Available on the market	

b) Performance

	System A	System B	System C		System D	System E1	System E2
Net data rate (transmissible rate without parity)	Symbol rate (R_S) is not fixed. The following net data rates result from an example R_S of 27.776 MBaud: 1/2: 23.754 Mbit/s 2/3: 31.672 Mbit/s 3/4: 35.631 Mbit/s 5/6: 39.590 Mbit/s 7/8: 41.570 Mbit/s	1/2: 17.69 Mbit/s 2/3: 23.58 Mbit/s 6/7: 30.32 Mbit/s	19.5 MBd 5/11: 16.4 Mbit/s 1/2: 18.0 Mbit/s 3/5: 21.6 Mbit/s 2/3: 24.0 Mbit/s 3/4: 27.0 Mbit/s 4/5: 28.8 Mbit/s 5/6: 30.0 Mbit/s 7/8: 31.5 Mbit/s	29.3 MBd 24.5 Mbit/s 27.0 Mbit/s 32.4 Mbit/s 36.0 Mbit/s 40.5 Mbit/s 43.2 Mbit/s 45.0 Mbit/s 47.2 Mbit/s	Up to 52.2 Mbit/s (at a symbol rate of 28.86 MBd)	Symbol rate (R_S) is not fixed. The following net data rates result from an example R_S of 27.776 MBd, normal FEC frame length and no pilots: QPSK 1/2: 27.467 Mbit/s QPSK 3/4: 41.316 Mbit/s 8-PSK 2/3: 55.014 Mbit/s 16-APSK 3/4: 82.404 Mbit/s ⁽⁵⁾ ⁽⁶⁾	8-PSK 25/36: 57.278 32-APSK 2/3 L (*): 91.437 64-APSK 5/6: 137.120 ⁽⁶⁾
Upward extensibility	Yes	Yes	Yes	Yes	Yes	Yes	Yes
HDTV capability	Yes	Yes	Yes	Yes	Yes	Yes	Yes
UHDTV capability	–	–	–	–	–	Yes	Yes
Selectable conditional access	Yes	Yes	Yes	Yes	Yes	Yes	Yes

(*) L indicates modes optimized for quasi-linear channels

TABLE 2 (continued)

c) Technical characteristics (transmission)

	System A	System B	System C	System D	System E1	System E2
Modulation schemes for broadcasting	QPSK	QPSK	QPSK	TC8-PSK/QPSK/BPSK	QPSK/8-PSK/16-APSK/32-APSK ⁽⁵⁾	QPSK/8-PSK/8-APSK-L/16-APSK/16-APSK-L/32-APSK/32-APSK-L/64-APSK/64-APSK-L/ ⁽⁶⁾
Symbol rate	Not specified	Fixed 20 MBd	Variable 19.5 and 29.3 MBd	Not specified (e.g. 28.86 MBd)	Not specified	
Necessary bandwidth (-3 dB)	Not specified	24 MHz	19.5 and 29.3 MHz	Not specified (e.g. 28.86 MHz)	Not specified	
Roll-off rate	0.35 (raised cosine)	0.2 (raised cosine)	0.55 and 0.33 (4th order Butterworth filter)	0.35 (raised cosine)	0.35, 0.25, 0.2 (raised cosine)	
					0.15, 0.10, 0.05 (raised cosine)	
Outer code	Reed Solomon (204, 188, $T = 8$)	Reed Solomon (146, 130, $T = 8$)	Reed Solomon (204, 188, $T = 8$)	Reed Solomon (204, 188, $T = 8$)	BCH (N, K, T) with parameters different according to the inner coding and frame length configuration	
Outer code generator	Reed Solomon (255, 239, $T = 8$)	Reed Solomon (255, 239, $T = 8$)	Reed Solomon (255, 239, $T = 8$)	Reed Solomon (255, 239, $T = 8$)	BCH (N, K, T) with parameters different according to the inner coding and frame length configuration	
Outer code generator polynomial	$(x + \alpha^0)(x + \alpha^1) \dots (x + \alpha^{15})$ where $\alpha = 02_h$	$(x + \alpha^0)(x + \alpha^1) \dots (x + \alpha^{15})$ where $\alpha = 02_h$	$(x + \alpha^1)(x + \alpha^2) \dots (x + \alpha^{16})$ where $\alpha = 02_h$	$(x + \alpha^0)(x + \alpha^1) \dots (x + \alpha^{15})$ where $\alpha = 02_h$	Different according to the inner coding and frame length configuration	
Field generator polynomial	$x^8 + x^4 + x^3 + x^2 + 1$	$x^8 + x^4 + x^3 + x^2 + 1$	$x^8 + x^4 + x^3 + x^2 + 1$	$x^8 + x^4 + x^3 + x^2 + 1$	Different according to the inner coding and frame length configuration	
Randomization for energy dispersal	PRBS: $1 + x^{14} + x^{15}$	None	PRBS: $1 + x + x^3 + x^{12} + x^{16}$ ⁶ truncated for a period of 4 894 bytes	PRBS: $1 + x^{14} + x^{15}$	PRBS n Gold sequences derived by the combination of two sequence constructed using the primitive (over GF(2)) polynomials $1+x^7+x^{18}$ and $1 + y^5 + y^7 + y^{10} + y^{18}$ $n \in [0, 262\ 141]$ The n^{th} Gold code sequence z_n $n = 0, 1, 2, \dots, 2^{18}-2$, is then defined as: $-z_n(i) = [x((i+n) \text{ modulo } (2^{18}-1)) + y(i)] \text{ modulo } 2, i = 0, \dots, 2^{18} - 2.$	

TABLE 2 (continued)

c) Technical characteristics (transmission)

	System A	System B	System C	System D	System E1	System E2
Loading sequence into pseudo random binary sequence (PRBS) register	100101010000000	Not Applicable	0001 _h	100101010000000	$n=0$ for broadcasting services	$n= i \times 10\,949$, with $i \in [0,6]$ for broadcasting services, to mitigate interference
Randomization point	Before RS encoder	Not Applicable	After RS encoder	After RS encoder	Before Modulation/ after bit mapping into Physical layer frame and optional pilot insertion	
Interleaving between inner and outer codes	Convolutional, $I = 12, M = 17$ (Forney)	Convolutional, $N1 = 13, N2 = 146$ (Ramsey II)	Convolutional, $I = 12, M = 19$ (Forney)	Block (depth = 8)	⁽²⁾	
Inner coding	Convolutional	Convolutional	Convolutional	Convolutional, trellis (8-PSK: TCM 2/3)	LDPC	
Constraint length	$K = 7$	$K = 7$	$K = 7$	$K = 7$	Not Applicable	
Basic code	1/2	1½	1/3	1/2	Not Applicable	
Generator polynomial	171, 133 (octal)	171, 133 (octal)	117, 135, 161 (octal)	171, 133 (octal)	Not Applicable	
Inner code block length	Not Applicable	Not Applicable	Not Applicable	Not Applicable	Normal FEC frame = 64 800 bits Short FEC frame = 16 200 bits	
					Medium FEC frame = 32 400 bits	

TABLE 2 (continued)

c) Technical characteristics (transmission) (end)

	System A	System B	System C	System D	System E1 ⁽³⁾	System E2 ⁽³⁾
Inner coding rate	1/2, 2/3, 3/4, 5/6, 7/8	1/2, 2/3, 6/7	1/2, 2/3, 3/4, 3/5, 4/5, 5/6, 5/11, 7/8	1/2, 3/4, 2/3, 5/6, 7/8	QPSK: 1/4, 1/3, 2/5, 1/2, 3/5, 2/3, 3/4, 4/5, 5/6, 8/9, 9/10 8-PSK: 3/5, 2/3, 3/4, 5/6, 8/9, 9/10 16-APSK: 2/3, 3/4, 4/5, 5/6, 8/9, 9/10 32-APSK: 3/4, 4/5, 5/6, 8/9, 9/10	QPSK: 13/45, 9/20, 11/20, 11/45, 4/15, 14/45, 7/15, 8/15, 32/45 8-PSK: 23/36, 25/36, 13/18, 7/15, 8/15, 26/45, 32/45 8-APSK-L : 5/9, 26/45 16-APSK: 26/45; 3/5; 28/45; 23/36; 25/36; 13/18; 7/9; 77/90 7/15, 8/15, 26/45, 3/5, 32/45 16-APSK-L: 5/9; 8/15; 1/2; 3/5; 2/3 32-APSK: 2/3, 32/45 32-APSK-L: 2/3 64-APSK: 11/15; 7/9; 4/5; 5/6 64-APSK-L: 32/45 ⁽⁶⁾
Transmission control	None	None	None	TMCC	Baseband and physical layer framing structure; optional pilots	
Frame structure	None	None	None	48 slot/frame 8 frame/super frame	Normal FEC frame = 64 800 bits Short FEC frame = 16 200 bits	Medium FEC frame = 32 400 bits
Superframing structure	No	No	No	No	No	Yes
Packet size (bytes)	188	130	188	188	188 for MPEG-TS Not specified for GS	
Transport layer	MPEG-2	Non-MPEG	MPEG-2	MPEG-2	Not specified	
Satellite downlink frequency range (GHz)	Originally designed for 11/12, not excluding other satellite frequency ranges	Originally designed for 11/12, not excluding other satellite frequency ranges	Originally designed for 11/12 and 4 satellite frequency ranges	Originally designed for 11/12, not excluding other satellite frequency ranges	Designed for 11/12 and 17/21, not excluding other satellite frequency ranges	

TABLE 2 (continued)

d) Technical characteristics (source coding)

		System A	System B	System C	System D	System E1	System E2
Video source coding	Syntax	MPEG-2	MPEG-2	MPEG-2	MPEG-2	MPEG-4 AVC MPEG-2 generic HEVC ⁽⁴⁾ Not restricted	
	Levels	At least main level	At least main level	At least main level	Main and high level	Level-3 and 4 Not restricted, applicable to all levels	
	Profiles	At least main profile	At least main profile	At least main profile	Main profile	Main profile Not restricted, all profiles usable	
Aspect ratios		4:3 16:9 (2.12:1 optionally)	4:3 16:9	4:3 16:9	4:3 16:9	4:3 16:9 (2.12:1 optionally) Not restricted	
Image supported formats		Not restricted, Recommended: 720 × 576 704 × 576 544 × 576 480 × 576 352 × 576 352 × 288	720 × 480 704 × 480 544 × 480 480 × 480 352 × 480 352 × 240 720 × 1 280 1 280 × 1 024 1 920 × 1 080	720(704) × 576 720(704) × 480 528 × 480 528 × 576 352 × 480 352 × 576 352 × 288 352 × 240	1 920 × 1 080 1 440 × 1 080 1 280 × 720 720 × 480 544 × 480 480 × 480 352 × 240 ^{(1),*} 176 × 120 ^{(1),*} (* for hierarchical transmission)	Recommended for MPEG-2: 720 × 576 704 × 576 544 × 576 480 × 576 352 × 576 352 × 288 Recommended for MPEG-4 AVC: 720 × 480 640 × 480 544 × 480 480 × 480 352 × 480 352 × 240 1 920 × 1 080 1 440 × 1 080 1 280 × 1 080 960 × 1 080 1 280 × 720 960 × 720 640 × 720 Recommended for HEVC ⁽⁴⁾ Not restricted	
Frame rates at monitor (per s)		25	29.97	25 or 29.97	29.97 or 59.94	25, 50 or 100, 24, 30, 60 or 120	

TABLE 2 (end)

d) Technical characteristics (source coding) (end)

	System A	System B	System C	System D	System E1	System E2
Audio source decoding	MPEG-2, Layers I and II	MPEG-1, Layer II; ATSC A/53 (AC3)	ATSC A/53 or MPEG-2 Layers I and II	MPEG-2 AAC	MPEG-1 Layer I, MPEG-1 Layer II or MPEG-2 Layer II backward-compatible audio MPEG-4 AAC, MPEG-4 ALS	
Service information	ETS 300 468	System B	ATSC A/56 SCTE DVS/011	ETS 300 468	Supported	
EPG	ETS 300 707	System B	User selectable	User selectable	Supported	
Teletext	Supported	Not specified	Not specified	User selectable	Supported	
Subtitling	Supported	Supported	Supported	Supported	Supported	
Closed caption	Not specified	Yes	Yes	Supported	Not specified	

- (1) Also applicable to news gathering, interactive services and other satellite applications.
- (2) Although Systems E1 and E2 do not use an interleaver between the inner and outer codes, there is a bit interleaver before the symbol mapper (except for QPSK).
- (3) Not all the inner coding rates are applicable to any FEC frame size.
- (4) Recommendation ITU-T H.265 (2013) | ISO/IEC 23008-2:2013: High efficiency video coding.
- (5) QPSK and 8-PSK are normative, 16-APSK and 32-APSK are optional for broadcast applications in DVB-S2.
- (6) QPSK, 8-PSK, 8-APSK-L, 16-APSK, 16-APSK-L, 32-APSK, and 32-APSK-L are normative for broadcasting, 64-APSK and 64-APSK-L are optional for broadcasting in DVB-S2X. Additionally, BPSK, 128-APSK, 256-APSK and 256-APSK-L are available in DVB-S2X, that are not applicable for broadcasting. L indicates modes optimized for quasi-linear channels.
- (7) For one-to-one and interactive services adaptive coding and modulation is available in addition to the transmitter power and inner code rate.

TABLE 3

Comparison characteristics table

Modulation and coding		System A		System B		System C		System D		System E1(9)		System E2(9)	
Modulation modes supported individually and on the same carrier		QPSK		QPSK		QPSK		8-PSK, QPSK, and BPSK		QPSK, 8-PSK, 16-APSK, 32-APSK ⁽¹⁰⁾⁽¹¹⁾			
										8-APSK-L, 16-APSK-L, 32-APSK-L, 64-APSK, 64-APSK-L ⁽¹¹⁾			
Performance (define quasi-error-free (QEF) required C/N (bit/s/Hz))		Spectral efficiency ⁽¹⁾	C/N for QEF ⁽¹⁾	Spectral efficiency	C/N for QEF ⁽²⁾	Spectral efficiency ⁽³⁾	C/N for QEF ⁽⁴⁾	Spectral efficiency	C/N for QEF ⁽⁵⁾	Spectral efficiency ⁽⁷⁾	C/N for QEF ⁽⁶⁾	Sp. eff. ⁽⁷⁾	C/N for QEF ⁽⁸⁾
Modes	Inner code												
BPSK Conv.	1/2	Not used		Not used		Not used		0.35	0.2	Not used			
QPSK	1/4	Not used		Not used		Not used		Not used		0.49	-2.3		
	13/45	Not used		Not used		Not used		Not used		Not used		0.57	-2.03
	1/3	Not used		Not used		Not used		Not used		0.66	-1.2		
	2/5	Not used		Not used		Not used		Not used		0.79	-0.3		
	5/11	Not used		Not used		0.54/0.63	2.8/3.0	Not used		Not used			
	9/20	Not used		Not used		Not used		Not used		Not used		0.89	0.22
	1/2	0.72	4.1	0.74	3.8	0.59/0.69	3.3/3.5	0.7	3.2	0.99	1.0		
	11/20	Not used		Not used		Not used		Not used		Not used		1.09	1.45
	3/5	Not used		Not used		0.71/0.83	4.5/4.7			1.19	2.2		
	2/3	0.96	5.8	0.98	5	0.79/0.92	5.1/5.3	0.94	4.9	1.32	3.1		
	3/4	1.08	6.8	Not used		0.89/1.04	6.0/6.2	1.06	5.9	1.49	4.0		
	4/5	Not used		Not used		0.95/1.11	6.6/6.8	Not used		1.59	4.7		
	5/6	1.2	7.8	Not used		0.99/1.15	7.0/7.2	1.18	6.8	1.65	5.2		
	6/7	Not used		1.26	7.6	Not used		Not used		Not used			
7/8	1.26	8.4	Not used		1.04/1.21	7.7/7.9	1.24	7.4	Not used				

TABLE 3 (continued)

Modulation and coding		System A	System B	System C	System D		System E1(9)		System E2(9)	
	8/9	Not used	Not used	Not used	Not used		1.77	6.2		
	9/10	Not used	Not used	Not used	Not used		1.79	6.4		
8-PSK Trellis		Not used	Not used	Not used	1.4	8.4	Not used			
8-APSK-L	5/9	Not used	Not used	Not used	Not used		Not used		1.65	4.73
	26/45	Not used	Not used	Not used	Not used		Not used		1.71	5.13
8-PSK	3/5	Not used	Not used	Not used	Not used		1.78	5.5		
	23/36	Not used	Not used	Not used	Not used		Not used		1.90	6.12
	2/3	Not used	Not used	Not used	Not used		1.98	6.6		
	25/36	Not used	Not used	Not used	Not used		Not used		2.06	7.02
	13/18	Not used	Not used	Not used	Not used		Not used		2.15	7.49
	3/4	Not used	Not used	Not used	Not used		2.23	7.9		
	5/6	Not used	Not used	Not used	Not used		2.48	9.3		
	8/9	Not used	Not used	Not used	Not used		2.65	10.7		
	9/10	Not used	Not used	Not used	Not used		2.68	11.0		
16-APSK-L	1/2	Not used	Not used	Not used	Not used		Not used		1.97	5.97
	8/15	Not used	Not used	Not used	Not used		Not used		2.10	6.55
	5/9	Not used	Not used	Not used	Not used		Not used		2.19	6.84
	3/5	Not used	Not used	Not used	Not used		Not used		2.37	7.41
	2/3	Not used	Not used	Not used	Not used		Not used		2.64	8.43
16-APSK	26/45	Not used	Not used	Not used	Not used		Not used		2.28	7.51
	3/5	Not used	Not used	Not used	Not used		Not used		2.37	7.80
	28/45	Not used	Not used	Not used	Not used		Not used		2.46	8.10
	23/36	Not used	Not used	Not used	Not used		Not used		2.52	8.38
	2/3	Not used	Not used	Not used	Not used		2.64	9.0		
	25/36	Not used	Not used	Not used	Not used		Not used		2.75	9.27
	13/18	Not used	Not used	Not used	Not used		Not used		2.86	9.71
	3/4	Not used	Not used	Not used	Not used		2.97	10.2		
	7/9	Not used	Not used	Not used	Not used		Not used		3.08	10.65
	4/5	Not used	Not used	Not used	Not used		3.17	11.0		

TABLE 3 (continued)

Modulation and coding		System A	System B	System C	System D	System E1(9)		System E2(9)	
	5/6	Not used	Not used	Not used	Not used	3.30	11.6		
	77/90	Not used	Not used	Not used	Not used	Not used		3.39	11.99
	8/9	Not used	Not used	Not used	Not used	3.52	12.9		
	9/10	Not used	Not used	Not used	Not used	3.57	13.1		
32-APSK-L	2/3	Not used	Not used	Not used	Not used	Not used		3.29	11.10
32-APSK	32/45	Not used	Not used	Not used	Not used	Not used		3.51	11.75
	11/15	Not used	Not used	Not used	Not used	Not used		3.62	12.17
	3/4	Not used	Not used	Not used	Not used	3.70	12.7		
	7/9	Not used	Not used	Not used	Not used	Not used		3.84	13.05
	4/5	Not used	Not used	Not used	Not used	3.95	13.6		
	5/6	Not used	Not used	Not used	Not used	4.12	14.3		
	8/9	Not used	Not used	Not used	Not used	4.40	15.7		
	9/10	Not used	Not used	Not used	Not used	4.46	16.0		
64-APSK-L	32/45	Not used	Not used	Not used	Not used	Not used		4.21	13.98
64-APSK	11/15	Not used	Not used	Not used	Not used	Not used		4.34	14.81
	7/9	Not used	Not used	Not used	Not used	Not used		4.60	15.47
	4/5	Not used	Not used	Not used	Not used	Not used		4.74	15.87
	5/6	Not used	Not used	Not used	Not used	Not used		4.93	16.55
Capable of hierarchical modulation control?	No	No	No	Yes	Yes				
Symbol rate characteristics	Continuously variable	Fixed, 20 MBd	Variable, 19.5 or 29.3 MBd	Continuously variable	Continuously variable				
Packet length (bytes)	188	130	188	188	188	188 for TS, user definable up to 64K for GS. Variable length packet streams, unpacketized streams or packet lengths exceeding 64K are possible, treated as continuous streams			
Transport streams supported	MPEG-2	System B	MPEG-2	MPEG-2	MPEG-2		MPEG-2 and generic stream (GS)		
							All-IP		

TABLE 3 (end)

Modulation and coding	System A	System B	System C	System D	System E1(9)	System E2(9)
Transport stream correspondence with satellite channels	One stream/channel	One stream/channel	One stream/channel		1 to 8 streams/channel	1 to 255 streams/channel
Support for statistical multiplex of video streams	No limitation within a transport stream	No limitation within a transport stream	No limitation within a transport stream		No limitation within a transport stream. Also, may be possible across transport streams within a satellite channel	No limitations within a transport stream. No limitations for generic streams

TWTA: travelling wave tube amplifier

IMUX: input multiplex

OMUX: output multiplex

- (1) At a BER $< 10^{-10}$. The C/N values for System A refer to computer simulation results achieved on a hypothetical satellite chain, including IMUX, TWTA and OMUX, with modulation roll-off of 0.35. They are based on the assumption of soft-decision Viterbi decoding in the receiver. A bandwidth to symbol rate ratio of 1.28 has been adopted. The figures for C/N include a calculated degradation of 0.2 dB due to bandwidth limitations on IMUX and OMUX filters, 0.8 dB non-linear distortion on TWTA at saturation and 0.8 dB modem degradation. The figures apply to BER = 2×10^{-4} before RS (204,188), which corresponds to QEF at the RS coder output. Degradation due to interference is not taken into account.
- (2) At a BER of 1×10^{-12} .
- (3) As calculated by $2(R_c)(188/204)/1.55$ or $2(R_c)(188/204)/1.33$ for System C normal and truncated transmit spectral shaping, respectively, where R_c is the convolutional code rate.
- (4) Theoretical QPSK (2-bit per symbol) E_s/N_0 , i.e. C/N as measured in baud rate bandwidth for normal and truncated spectral shaping, respectively. Does not include hardware implementation margin or satellite transponder loss margin.
- (5) These values were derived from computer simulations and regarded as theoretical values. The values apply to BER = 2×10^{-4} before RS (204, 188) with baud rate bandwidth (Nyquist bandwidth). Does not include hardware implementation margin or satellite transponder loss margin.
- (6) These values were derived from computer simulations, 50 LDPC fixed-point decoding iterations, perfect carrier and synchronization recovery, no phase noise, AWGN channel. FEC frame length is 64 800 bits. The values apply to PER = 10^{-7} , where PER is the ratio, after forward error correction at the receiver, between the useful transport stream packets (188 bytes) affected by error and the totally received ones. Does not include hardware implementation margin or satellite transponder loss margin.
- (7) Defined as the useful bit rate per unit symbol rate without pilots.
- (8) These values were derived from computer simulations, 50 LDPC iterations, perfect carrier and synchronization recovery, no phase noise, AWGN channel. FEC frame length is 64 800 bits. The values apply to FER = 10^{-5} , where FER is the ratio, after forward error correction at the receiver, between the number of received normal FEC frames affected by error and the totally received ones. It does not include hardware implementation margin or satellite transponder loss margin.
- (9) The listed modulation and coding configurations refer to the normal FEC frame.
- (10) QPSK and 8-PSK are normative, 16-APSK and 32-APSK are optional for broadcast applications in DVB-S2.
- (11) QPSK, 8-PSK, 8-APSK-L, 16-APSK, 16-APSK-L, 32-APSK, and 32-APSK-L are normative for broadcasting, 64-APSK and 64-APSK-L are optional for broadcasting in DVB-S2X. Additionally, 128-APSK, 256-APSK and 256-APSK-L are available in DVB-S2X, that are not applicable for broadcast applications. L indicates modes optimized for quasi-linear channels.

Attachment 1 to Annex 3

ETSI EN 302 307-1 V1.4.1, *Digital Video Broadcasting (DVB); Second generation framing structure, channel coding and modulation systems for Broadcasting, Interactive Services, News Gathering and other broadband satellite applications; Part 1: DVB-S2*,
http://www.etsi.org/deliver/etsi_en/302300_302399/30230701/01.04.01_60/en_30230701v010401p.pdf

Attachment 2 to Annex 2

ETSI EN 302 307-2 V1.1.1, *Digital Video Broadcasting (DVB); Second generation framing structure, channel coding and modulation systems for Broadcasting, Interactive Services, News Gathering and other broadband satellite applications; Part 2: DVB-S2 Extensions (DVB-S2X)*,
http://www.etsi.org/deliver/etsi_en/302300_302399/30230702/01.01.01_60/en_30230702v010101p.pdf
