

International Telecommunication Union

ITU-R
Radiocommunication Sector of ITU

Report ITU-R M.2117-1
(11/2012)

**Software-defined radio in the land mobile,
amateur and amateur-satellite services**

M Series
**Mobile, radiodetermination, amateur
and related satellite services**



International
Telecommunication
Union

Foreword

The role of the Radiocommunication Sector is to ensure the rational, equitable, efficient and economical use of the radio-frequency spectrum by all radiocommunication services, including satellite services, and carry out studies without limit of frequency range on the basis of which Recommendations are adopted.

The regulatory and policy functions of the Radiocommunication Sector are performed by World and Regional Radiocommunication Conferences and Radiocommunication Assemblies supported by Study Groups.

Policy on Intellectual Property Right (IPR)

ITU-R policy on IPR is described in the Common Patent Policy for ITU-T/ITU-R/ISO/IEC referenced in Annex 1 of Resolution ITU-R 1. Forms to be used for the submission of patent statements and licensing declarations by patent holders are available from <http://www.itu.int/ITU-R/go/patents/en> where the Guidelines for Implementation of the Common Patent Policy for ITU-T/ITU-R/ISO/IEC and the ITU-R patent information database can also be found.

Series of ITU-R Reports

(Also available online at <http://www.itu.int/publ/R-REP/en>)

Series	Title
BO	Satellite delivery
BR	Recording for production, archival and play-out; film for television
BS	Broadcasting service (sound)
BT	Broadcasting service (television)
F	Fixed service
M	Mobile, radiodetermination, amateur and related satellite services
P	Radiowave propagation
RA	Radio astronomy
RS	Remote sensing systems
S	Fixed-satellite service
SA	Space applications and meteorology
SF	Frequency sharing and coordination between fixed-satellite and fixed service systems
SM	Spectrum management

Note: This ITU-R Report was approved in English by the Study Group under the procedure detailed in Resolution ITU-R 1.

Electronic Publication
Geneva, 2013

© ITU 2013

All rights reserved. No part of this publication may be reproduced, by any means whatsoever, without written permission of ITU.

REPORT ITU-R M.2117-1

**Software-defined radio in the land mobile, amateur
and amateur-satellite services**

(2012)

Summary

The Report was revised based on the recent results of ITU-R studies on SDR and CRS. The recent ITU-R study gives clear definitions to SDR and CRS. The contents on cognitive radio system (CRS) and its related technologies were removed from this Report since the topics on CRS are elaborated and well-described in Report ITU-R M.2225. The term “IMT-2000 and systems beyond IMT-2000” was changed to general terminology of “IMT systems”, taking into account the progress of the ITU-R study on IMT-2000 and IMT-Advanced. The SDR applications to ITS, PPDR as well as amateur and amateur-satellite systems were also updated according to the recent advance of the related technologies.

TABLE OF CONTENTS

	<i>Page</i>
1 Introduction	3
2 Scope	3
3 Related texts	3
4 Definition.....	4
5 Characteristics of SDR	5
5.1 Functional characteristics	5
5.2 Operational characteristics.....	5
5.3 Technical and architectural characteristics.....	6
6 Software download.....	8
6.1 Security characteristics	8
7 Deployment considerations	9
7.1 Vertical, horizontal industry models.....	9
8 Operational considerations	10
8.1 Spectrum usage and flexibility	10
8.2 Implications for certification and conformity.....	10

	<i>Page</i>
8.3 Implications for circulation.....	11
9 Implementation of SDR in specific land mobile systems and applications	12
9.1 IMT systems	12
9.2 Wireless access systems (WAS) including radio local area networks (RLAN).....	13
9.3 Public protection and disaster relief (PPDR) applications	14
9.4 Intelligent transport systems (ITS) applications	16
9.5 Amateur and amateur satellite systems.....	18
9.6 Other land mobile systems.....	19
10 Technology aspects related to IMT systems	19
10.1 Status of R&D.....	20
10.2 Items for future study.....	23
Annex A – Technical aspects related to IMT systems.....	24
1 Aspects of antenna systems	24
1.1 Monopole antenna using human body	24
1.2 Software adaptive antenna	25
1.3 RFU.....	29
1.4 AD/DA converters	30
1.5 Sampling rate conversion filter.....	31
1.6 Reconfigurable baseband processor.....	33
1.7 High-speed software switching.....	34
1.8 Simultaneous multiple communication	35
1.9 Communication system selection	36
Annex B – External organizations	38

1 Introduction

Radio technology continues to migrate towards reprogrammable radios, which can be reconfigured via software to adapt to changing communication protocols and frequency bands.

This technological evolution to software-defined radios (SDR) may have a profound effect on interoperability, on spectrum utilization and allocation in general, and on all technology partners from chip vendors and service providers to users. The impact of SDR could be far-reaching with possible applications in government systems, emergency response, medical communications, automobile sensors, commercial wireless systems and more.

2 Scope

This Report addresses the application and implications of SDR to land mobile systems, including, but not limited to, IMT systems, dispatch systems, intelligent transport systems (ITS), public mobile systems including public protection and disaster relief (PPDR), first and second generation cellular systems including their enhancements, and amateur and amateur-satellite systems. It addresses issues on the characteristics, software download and its security, operational considerations such as spectrum usage and flexibility as well as certification and conformity, and SDR applications to specific land mobile systems.

3 Related texts

ITU-R Recommendations

- ITU-R F.1399 – Vocabulary of terms for wireless access
- ITU-R M.687 – International Mobile Telecommunications-2000 (IMT-2000)
- ITU-R M.1033 – Technical and operational characteristics of cordless telephones and cordless telecommunication systems
- ITU-R M.1035 – Framework for the radio interface(s) and radio sub-system functionality for International Mobile Telecommunications-2000 (IMT-2000)
- ITU-R M.1036 – Frequency arrangements for implementation of the terrestrial component of International Mobile Telecommunications (IMT) in the bands identified for IMT in the Radio Regulations (RR)
- ITU-R M.1073 – Digital cellular land mobile telecommunication systems
- ITU-R M.1450 – Characteristics of broadband radio local area networks
- ITU-R M.1453 – Intelligent transport systems – Dedicated short range communications at 5.8 GHz
- ITU-R M.1457 – Detailed specification of the radio interfaces of International Mobile Telecommunications-2000 (IMT-2000)
- ITU-R M.1579 – Global circulation of IMT-2000 terrestrial terminals
- ITU-R M.1580 – Generic unwanted emission characteristics of base stations using the terrestrial radio interfaces of IMT-2000
- ITU-R M.1581 – Generic unwanted emission characteristics of mobile stations using the terrestrial radio interfaces of IMT-2000

- ITU-R M.1645 – Framework and overall objectives of the future development of IMT-2000 and systems beyond IMT-2000
- ITU-R M.1652 – Dynamic frequency selection in wireless access systems including radio local area networks for the purpose of protecting the radiodetermination service in the 5 GHz band
- ITU-R M.1678 – Adaptive antennas for mobile systems
- ITU-R M.1797 – Vocabulary of terms for the land mobile service
- ITU-R M.2012 – Detailed specifications of the terrestrial radio interfaces of International Mobile Telecommunications Advanced (IMT-Advanced).

ITU-R Reports

- ITU-R M.1021 – Equipment characteristics for digital transmission in the land mobile services
- ITU-R M.1025 – Technical and operating characteristics of cordless telephones
- ITU-R M.1156 – Digital cellular public land mobile telecommunication systems (DCPLMTS)
- ITU-R M.1157 – Integration of public mobile radiocommunication systems
- ITU-R M.2014 – Digital land mobile systems for dispatch traffic
- ITU-R M.2033 – Radiocommunication objectives and requirements for public protection and disaster relief
- ITU-R M.2038 – Technology trends
- ITU-R M.2040 – Adaptive antennas concepts and key technical aspects
- ITU-R M.2225 – Introduction to cognitive radio systems in the land mobile service
- ITU-R M.2242 – Cognitive radio systems specific for IMT systems
- ITU-R SM.2152 – Definitions of software-defined radio (SDR) and cognitive radio system (CRS).

Handbooks

- Land Mobile Handbook (including Wireless Access) Volume 1: Fixed Wireless Access – Second Edition
- Land Mobile Handbook (including Wireless Access) Volume 2: Principles and Approaches on Evolution to IMT-2000/FPLMTS
- Land Mobile Handbook (including Wireless Access) Volume 3: Dispatch and Advanced messaging Systems
- Land Mobile Handbook (including Wireless Access) – Volume 4: Intelligent Transport Systems
- Migration to IMT-2000 Systems – Supplement 1 to the Handbook on Deployment of IMT-2000 Systems
- Land Mobile Handbook (including Wireless Access) Volume 5: Deployment of Broadband Wireless Access.

4 Definition

Software-defined radio (SDR) has been defined in Recommendation ITU-R M.1797 and Report ITU-R SM.2152.

5 Characteristics of SDR

5.1 Functional characteristics

The ability of a radio to enable multiple air interfaces, add new ones as they are developed, and even act as a bridge between incompatible ones stems naturally from the SDR-supported ability to add or reconfigure air interfaces by using software. SDR may lengthen the useful life of legacy systems, diminish the barriers to communications and ease the transition from legacy radios to new ones. The level of interoperability will develop incrementally as SDR technology advances and expands the universe of standards, frequency bands, and modulations over which SDR-enhanced equipment can operate reliably, and as other infrastructure issues that might hinder interoperability are resolved.

There are some practical considerations which may limit the use of SDR for a particular communication system, including power limitations, cost, size and weight. Technology advances may diminish these limitations with time. As the processing power of computer chip technology has allowed smaller and lighter computers with increased functionality, the same technology advances will allow more functions to be integrated into radio devices, including handheld devices.

An SDR capable of emulating a number of air interfaces today will still be able to emulate those same air interfaces over many years. However, SDR technology does not guard against eventual hardware obsolescence. There will come a point in time when future applications are too complicated to run on specific generation of hardware.

5.2 Operational characteristics

SDR can provide an effective means to bridge operational requirements involving multiple bands and protocols. However, unless the air interfaces are standardized or the software framework used to implement SDR is common, there will always be interoperability issues between radio vendors. These air interface protocols establish a language that the radio will use when speaking with the system. These standardized air interface protocols identify features, such as encryption, authentication, scanning, priority, emergency, caller-ID, and define how they will work. Radios developed using different proprietary air interfaces will not be able to communicate unless the air interfaces can be exchanged from one radio platform to another one. This exchange can be achieved if the air interfaces have been developed using a common software framework.

Services and applications can be implemented with SDR to facilitate interoperability in any of several ways. The specific method chosen will be market-driven, but the following are possible ways that interoperability can be achieved:

- 1) Bridging between multiple air interfaces.
- 2) Allowing a subscriber to enable his equipment to implement a specific service according to his/her requirements.
- 3) Device reconfiguration that includes everything from enabling tokens to entire protocol stacks and air interfaces. The specific reconfiguration process could itself take one of several possible forms, including:
 - over the air transmission;
 - infrared link;
 - download from a personal computer;
 - reconfiguration while in a battery charger;
 - factory authorized update at local kiosks; or
 - memory card insertion.

The ability to reconfigure an SDR radio and system will require protection mechanisms. The radio must be protected from being reconfigured to transmit in an inappropriate way. The radio and system should be protected from reconfiguration by individuals with malicious intent and from inadvertent flawed reconfiguration.

An aspect of SDR that is important to mobile system interoperability is the SDR-enabled flexibility to allow operation with multiple air interfaces, given the use of available specifications, and across multiple RF bands. An SDR-enabled device can be used in many different systems by employing its capability to operate in the particular RF band and over the particular air interface that is in use by the system. This allows a user with an SDR-enabled device to roam into various different systems and communicate with the local users on that system. When an SDR-enabled radio is used in conjunction with a system employing a cross-networking interface, a capability to communicate with local system users and remote users on other systems is established. The software in an SDR allows easy selection of the RF band, air interface, and group affiliation. The selection could be done automatically if the radio has policy-based or cognitive capabilities.

The ability described above, to allow heterogeneous radios to communicate together by changing their air interface, could be further enabled by the following items:

- The air interface specifications are made public so that every radio vendor can implement and offer them on their radio.
- The software architecture(s), on which the air interfaces are built, allows air interface software developed by Company A to be used on a Company B's radio.

5.3 Technical and architectural characteristics

Consistent with the definition of SDR provided in Recommendation ITU-R M.1797 and Report ITU-R SM.2152, a radio is considered to be an SDR if some or all of the baseband or RF signal processing is accomplished through the use of software and can be modified post manufacturing. This functionality is depicted in the upper portion of Fig. 1.

The air interface selection functionality, depicted in the lower portion of Fig. 1, is the control mechanism that selects the proper air interface to establish the communications and modifies the transmit/receive parameters accordingly. While this selection can be done manually, two adaptive control mechanisms have been identified: policy-based or cognitive. The difference between the two resides in their approach to derive to control the proper air interface.

FIGURE 1
Example of SDR concepts

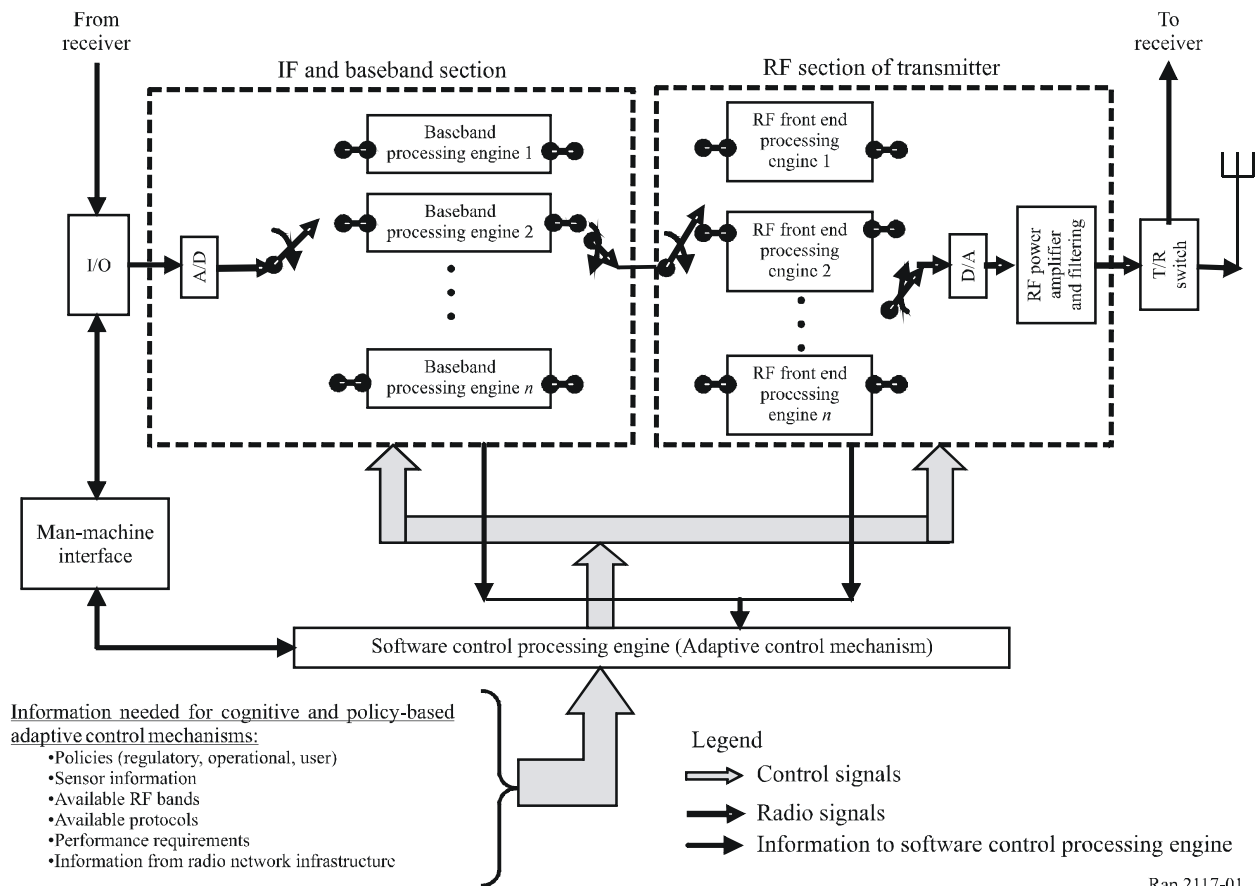

Rap 2117-01

The SDR abstraction includes a full chain of baseband hardware, signal-processing, interfaces and computing elements supported by suitable RF conversion and antenna technology. The RF components may be designed specifically for the individual frequency bands of interest for the particular system implementation.

The baseband devices may include general purpose processors (GPP), digital signal processors (DSP) and field programmable gate arrays (FPGA) and are supported by the applications programming interface (API) of the radio software system (SCA). The SDR may thus include traditional sequential “turing machine” software sequences as well as coded hardware functions that are optimized for the particular desired waveform. The “software” of the SDR may thus include both traditional program coding as well as logic gate coding.

At an international level, work has been done on the hardware and software architecture, with strong interest in flexible radio systems to promote efficiency in their use of assigned channels, interoperability and lower costs. A software architecture specification called “software communications architecture” (SCA) provides a real-time software operating-system environment to support the dynamic waveform generation and signal processing aspects of a radio as well as the administrative aspects for radio installation and change control¹. Such an example of standardized architecture of hardware and software will lead to generic, flexible radio systems which may be loaded with applications to suit particular operating scenarios. They may later be reloaded and reconfigured to suit new opportunities. Some SDR may be flexible enough to operate in several

¹ The SCA is not an operating system in itself, but a common set of features, interfaces and capabilities that are built on a real-time operating system (RTOS).

modes at the same time and some may be capable of changing or adding modes while continuing operation in other modes.

6 Software download

Software download of air-interfaces or radio standards, in particular over the air, is one of the most important SDR topics. The download of application software is not included within SDR, as that software does not directly relate to radio regulation. The download of radio software is not new topic in mobile phones. Due to the complexity and rapid evolution of standards, a program code is kept in non-volatile memory and can, in the majority of the devices currently on the market, be reloaded or modified after manufacturing. Security mechanisms such as signed code (digital signature) are needed. It is probably in the interest of the industry to standardize this aspect up to the extent that “due diligence” in this area is clearly defined (especially relevant for horizontal market models). Since progress is also expected for security solutions, it is not desirable to prescribe details in advance. If the adequate level of security is assured, the method, medium and time of software download should not be of any concern.

In the context of software download, it is useful to distinguish between downloads of code and download of air-interface parameters.

- Download of code may be defined as the download of the complete executable code, parameters, standard description, etc. which implements a certain air-interface standard or serves as the update or replacement of some of its modules. This feature is useful and will be extended within the next few years so as to allow for upgrades of device capabilities. A user may, for instance, buy support for a newer version of a standard or for an additional standard. A European customer may want to upgrade his device for use in the United States of America, or vice versa, by adding new software. Operators may distribute upgrades of original manufacturer software. A variety of methods and media can be employed to this end, ranging from memory cards, CD-ROM and Internet or over-the-air download.
- Download of air-interface parameters may be defined as the selection from pre-defined operational modes or the re-parameterization of functionality, relating, e.g. to transmit frequency, power, modulation, burst structure, encoding, timing, certain aspects of the protocol, etc., which can be described by parameters or templates. This does not in general require the exchange of executable code. Only a concise set of well-defined and easily standardized parameters or descriptive information has to be transmitted.

In general, the radio links, download and reconfiguration management and maintenance for a terminal can be either more user-controlled or network-controlled. Potential upgrades for a terminal should be managed by the network, service provider and/or manufacturer based on a delineation of responsibilities.

6.1 Security characteristics

An essential aspect for the acceptance and the success of the SDR concept is the security characteristic. It has to be ensured that neither the radio functionality of an SDR terminal or base station is altered unintentionally nor that unauthorized sources have access to SDR related components. A secure configuration/reconfiguration of the terminals is seen to be feasible by cooperation of the involved parties.

Nonetheless, aspects of rollback mechanisms and fault management have to be considered and developed. Regarding rollback mechanisms, it has to be ensured that after incomplete or faulty download of a new standard the terminal can switch back to a safe starting position.

As stated in Annex B, different organizations outside ITU are currently working on secure software download aspects since it is and it will become an important topic for telecommunication devices. Since this aspect is essential and vital for all involved parties, sophisticated solutions for secure download mechanisms will be provided by the industry.

Accordingly, there are technical study items regarding the assurance of security. These are examples of such study items that may facilitate secure operation:

- How to assure integrity of the software, and how to prevent malicious software (malware) such as Trojan horses and computer viruses from being installed by hackers.
- How to protect private information.
- How to authenticate the identity of individuals intending to install software.
- How to identify the consistency between terminal and software.
- How to recover from a failure of installation.

When a number of systems are installed in a terminal, there are study items regarding terminal addressing and user management:

- Whether every system has different addresses for identification.
- How to manage the address resource and how to avoid duplication of addresses and shortage of the address resource.
- How operators gather information about the system which is installed on a terminal to use their services.

It is noted that output of ITU-T Study Group 17 on security aspects is relevant to this topic.

7 Deployment considerations

7.1 Vertical, horizontal industry models

The aspect of software download will play an important role for SDR technology, therefore, a differentiation of the diverse types of software might be useful for the discussion. Figure 2 shows a possible (rough) graduation of software present in SDR terminals or base stations. As will be explained in more detail subsequently in the document, a distinction has to be made between software that has influence on or controls RF/air-interface parameters and software that has no influence on such parameters. Only radio-related software needs further consideration.

FIGURE 2
Schematic of different types of software present in
an SDR terminal or base station

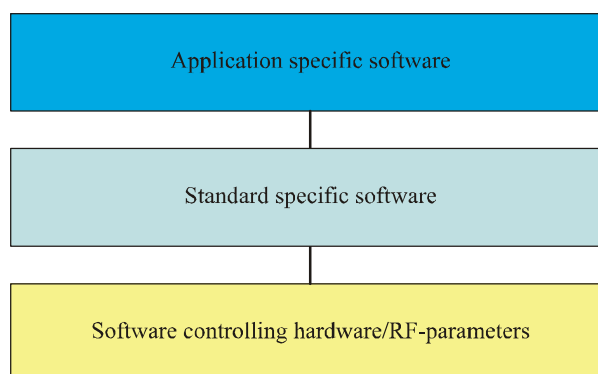

Due to the complexity of technology and due to security aspects there might be a stepwise SDR market evolution. In a first step the vertical model seems to be a near-term industry model. Here “vertical” means that all hardware and software components are under responsibility of only one entity (e.g. via contracts or certification processes) which is responsible for the conformity and faultless functioning of both. This well-defined responsibility ensures that the devices will operate within their licensing limits.

In a horizontal model the situation is quite more complex since many different independent companies will develop and offer SDR hardware and/or software components based on open interfaces. A close cooperation of all involved parties is a prerequisite for a successful SDR market evolution. In particular, mechanisms have to be elaborated to ensure that the hardware of company X is compliant with the software of company Y. Before new software or hardware components are offered to the market these components have to pass through validation processes and have to perform test cycles successfully. It sounds reasonable that this validation process can be performed by the involved industry players self-dependently. Special security mechanisms may have to be applied to reduce the risk of unintended or criminal modification of radio functionality. For instance by using appropriate security processes, adequate safeguards from software manufacturers can be installed on hardware platforms, which can be used by those concerned to verify that the downloaded and encrypted software modules originate from the original software manufacturers.

It is of vital interest to software and hardware manufacturers to ensure that functional products will be offered. Due to this fact many industry players are already working on suitable and powerful solutions in different organizations and projects to develop secure software download mechanisms (see e.g. Wireless Innovation Forum or European Projects like TRUST, SCOUT and E2R). These secure download mechanisms are not a special feature of SDR, but are and will be become more important for other technologies.

8 Operational considerations

8.1 Spectrum usage and flexibility

Current spectrum management techniques provide for designating specific frequency bands for each mobile radio services. SDR may enable legacy operation by current radio implementations.

In addition to current uses, SDR can assist to provide access to those bands already allocated to a particular service, as well as assisting in allocation of additional harmonized frequency bands for services. While the operating frequency and other channel parameters such as modulation type, error coding scheme and power could be manually selected, this would most likely be much too slow and be prone to errors which would result in unacceptable interferences.

8.2 Implications for certification and conformity

The impacts to certification arise from the fact that historical certification regimes have been developed based on an *ex ante* determination that the operating parameters of the device are in accordance with local regulations. Such regimes have no mechanisms to deal with a fundamental capability attributed to SDRs – that such devices can change their operating parameters *ex post* of its certification or declaration of conformity.

Administrations have also recognized the conformity issues and have begun activities to examine and/or modify conformity regulations to enable SDR devices to be deployed.

Common themes and questions are being addressed, including modifying existing conformity regulations to authorize the use of SDR and adaptive control mechanisms.

Certification and conformity issues:

- Enabling such radios to be reconfigured in the field by establishing rules to allow for equipment identification, recertification or declaration of conformity of such terminals post deployment.
- Conformance certification.
- Software installation issues such as:
 - installation rights;
 - installer certification;
 - media delivery;
 - user and operator installation;
 - installation procedures and mechanisms;
 - recovery from installation failure.
- Roaming and reconfiguration mechanisms.
- Prevention of unauthorized software changes.
- Prevention of harmful interference.

8.2.1 IMT system technical considerations necessary to insure conformance with ITU Recommendations and Radio Regulations

Worldwide roaming, one of the key features of IMT systems, requires the global circulation of terminals.

Flexible terminal implementation including that offered by SDR, enables a single terminal to support multiple standards, facilitating worldwide roaming.

Flexible implementations of IMT terminals and (e.g. those implemented by SDR, etc.) will be subject to the same procedures as conventional IMT terminals, i.e. global circulation and interference performance is covered by Recommendation ITU-R M.1579 – Global circulation of IMT-2000 terminals.

SDR technology may have some impact on the procedures for conformity assessment of terminals because they may work in several different ways. A number of administrations are therefore considering how the current procedures might be enhanced to address the considerations related to SDR.

However, common principles would facilitate the global circulation of such flexible terminals.

Examples of issues which are being addressed:

- equipment identification/marketing, re-certification or declaration of conformity of such terminals post deployment;
- software/hardware configuration issues;
- security and integrity issues;
- prevention of unauthorized software changes;
- prevention of harmful interference.

8.3 Implications for circulation

In order to address the new scenarios introduced by SDR, it may be necessary to review the technical basis for circulation.

Common themes and questions arise when administrations examine existing conformity regulations to authorize the use of SDR. However, though common themes and questions are being addressed, different approaches might be taken by different administrations to achieve the desired effect.

For instance one administration may require a specific type approval for SDRs, requiring that the manufacturer take steps to ensure that only RF software that has been approved with a SDR can be loaded into such a radio. The software should safeguard the user from operating the transmitter with frequencies, output power, modulation types or other parameters outside of those that were approved. Administrations with other conformity regimes might require different procedures.

9 Implementation of SDR in specific land mobile systems and applications

This section addresses the application and implications of SDR to various land mobile systems.

SDR offers advantages for these systems at the functional level as well as facilitating interworking with other systems and supporting multi-vendor interoperability. Original equipment manufacturers (OEMs) serving increasingly more complex and diverse market conditions may be attracted by the ability to configure a standard product platform to address multiple markets. The benefits include lower costs, faster-to-market new products and better tailored products for target markets. Thus, the concept of a highly (re)configurable base station or handset communication device is very attractive to radio OEMs even before the consideration of multiband, multi-mode functionality, or the in-use over-the-air reconfiguration capability.

9.1 IMT systems

Recommendation ITU-R M.1035 deals with the concept of IMT-2000, including core elements and radio interface characteristics, and is a useful guideline for this section. Looking at the IMT high-level system architecture, the following sub-systems can be identified, as shown in Fig. 3:

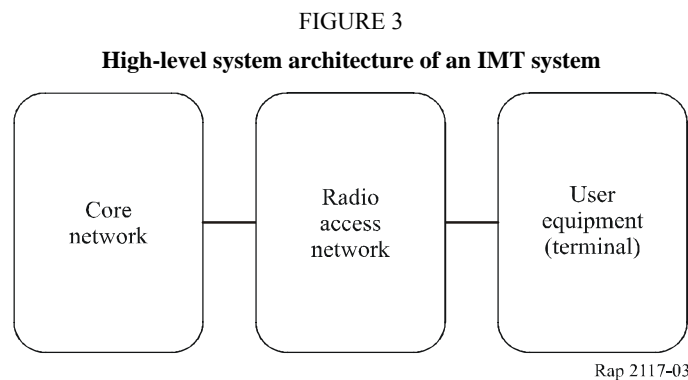

SDR will have some impact on these sub-systems and on their interworking.

- In particular the user equipment (terminals) and their network interface are most affected since the different standards have to be implemented into the terminal. Implementation of the various IMT radio interface standards leads to different technical requirements in regard to the terminal capabilities e.g. storage capacities, computing power and power consumption. The main objective for introducing SDR technology into the base station, and its controllers of the mobile radio access network (RAN), is to increase the flexibility of the RAN.

Moving the reprogrammable elements as close to the front-end as possible allows introduction of very flexible platforms that can be (re)configured by software for different air-interface standards and multiple frequency bands.

The use of SDR potentially enables the base station to be “reconfigured” which could include the change of functionality, for instance changing from one IMT radio access technology to another, as well as the partial modification or update of certain aspects of a radio access technology, such as the introduction of an optional capability or a new version.

Terminal reconfiguration favours worldwide roaming and interoperability, because, ideally, one single terminal might be reconfigured to employ any radio access technology and/or access differing frequency bands. Likewise, it enables the separation of services offered to the user, and the technology used to provide them. It also makes the correction of software errors easier and more effective, as the need for recalling defective terminals is substantially reduced or eliminated altogether through downloadable, terminal software changes.

9.1.1 User benefits

Modern high-performance mobile terminals are becoming more and more complex due to an increase in terminal capabilities and an increased amount of software (application as well as operational software). For the user, SDR terminals that can be upgraded or enhanced in their capabilities at a later date may be a great benefit and a criterion for buying them. In the long term, the user terminal will be upgradeable and reconfigurable via software downloads over the air.

Implementation of an SDR base station and terminals may bring other benefits for the user, such as improved roaming and interoperability.

9.1.2 Manufacturer benefits

Some driving forces behind the developments towards SDR are reduction of time-to-market of devices, reduction of development and manufacturing costs, wider market access and multi-standard support capability.

For the terminal manufacturers SDR offers the possibility of using one and the same terminal platform for different applications. In particular manufacturers can start the development of terminals at an earlier stage in the development of the standard. Ideally, adoptions of changes to standards can easily be performed without modifying hardware components.

Apart from standards of the IMT family, there is a trend of integrating more and more standards like Bluetooth, IEEE 802.11, GPS, DVB and DAB into the user terminals. SDR technology may facilitate this integration of existing and future standards.

9.2 Wireless access systems (WAS) including radio local area networks (RLAN)

WAS devices can operate on a licensed or licence-exempt basis. In addition to widespread deployment for networking computers in companies and for personal computers in private homes, many international carriers and service providers are offering service via “hot-spots”. This has been termed “heterogeneous roaming” – staying connected to the same operators, but roaming between different air interfaces.

However, operations on a licence-exempt basis may raise some special concerns. As such operations tend to be localized and varied in nature, devices have traditionally been used for personal, localized purposes, rather than for widespread commercial services by major carriers or service providers. Thus, a case-by-case treatment with regard to operating parameters may significantly raise costs in the manufacturing and certification of the devices due to uncertainty in product planning as well as the unreliability of quality of service (QoS) in operation. Many of the variations are small; the use of WAS is still allowed and viable but needs to be slightly different because of local needs. Examples are variations in power restrictions because of other devices sharing spectrum.

SDR will allow manufacturers to develop a product once making it deployable globally and allowing jurisdictions to tailor-fit it to fit local needs.

9.3 Public protection and disaster relief (PPDR) applications

PPDR systems have special functional and operational requirements, including their need for high reliability, interoperability, and availability in harsh operational environments.

A critical challenge, often faced by the people and agencies responsible for PPDR operations, is the incompatibility of their radiocommunication equipment. It is frequently the case, even within a particular city, that the police, fire, and ambulance services use incompatible equipment operating with incompatible protocols in incompatible bands. The situation is typically even worse across jurisdictions. This challenge reaches its peak in the face of a large-scale emergency that requires the cooperation of first responders from multiple agencies and multiple jurisdictions. Larger emergencies increase the likelihood of non-interoperability and incompatibility of the communication systems used by the people and agencies whose cooperation is crucial to saving lives, thereby hindering the quick and effective resolution of the emergency.

Public safety and emergency first responders, as well as disaster relief aid teams, need industry standards that lead to interoperable and cost-effective equipment and services for both routine and extraordinary operations. These, and other requirements mentioned in this section, make the case for SDR-based new PPDR communication systems. It is important that authorities and organizations around the world collaborate in the development of these standards for PPDR communications and that they share information on emerging technologies and services. The adoption of the LTE standard for broadband public safety use in several administrations is an encouraging development in this regard. Resolution 646 (Rev.WRC-12)² was adopted to promote harmonization of spectrum for PPDR applications. Efforts are under way to develop harmonized standards for some of these bands. However, more can and should be done to address the existing problem of incompatible communication equipment used by public safety agencies.

Enhanced voice communications is a critical component in PPDR operations. However, new data and video services will play an increasingly important role in emerging PPDR applications. Wideband and broadband communication services that support these applications will benefit from the use of state-of-the-art, spectrum-efficient technologies, such as advanced antenna techniques, adaptive coding and modulation techniques and support advanced automatic networking features like self-organization and self-configuration (SON).

SDR represent a strategic opportunity to meet many of the PPDR-specific requirements mentioned above. For example: by allowing the dynamic reconfiguration of radio operational characteristics, SDR-based radio systems can adapt to varying operational scenarios, such as an unexpected interference that renders some planned channels inoperative and the need to switch to alternate or unplanned channels, or, the need to continue normal operations in case of failure of the communication systems infrastructure – this is when direct mobile to mobile communications, as well as support for high-speed ad hoc local area networks, is highly desirable. Another example which is quite common in large-scale disaster events is the need to conduct complex operations and coordination with a large number of responders from different jurisdictions as well as with volunteers on the scene, including foreign disaster-relief teams who use portable and vehicular radio equipment of different characteristics than those used by the local teams. In this case, SDR-based PPDR radio systems would provide the ability to adapt and cross-communicate with legacy radios.

In summary, the use of SDR-based radio systems provides the flexibility and communication mechanisms through which:

² Resolution 646 (Rev.WRC-12) – Public protection and disaster relief.

- individual agencies would be able to function independently in normal operations, without interference from the equipment of other agencies; and
- agencies would be able to communicate with one another when cooperation between them is necessary.

9.3.1 Interworking and interoperability

9.3.1.1 Interworking

Currently, disparate public safety systems can intercommunicate (i.e. interwork) with the help of audio cross-patch panels installed in dispatch stations and used in the field as well, connecting one of each kind of radio to another. This technique does not support the enforcement of sophisticated priority-of-service rules required in multi-agency and multi-jurisdiction emergency situations. SDR technology, implemented in portable/mobile radios, will be a prime enabler of more efficient and reliable cross-network communications.

An aspect of SDR that is important to the interworking of PPDR communication systems is the SDR-enabled flexibility to allow operation with multiple air interfaces. The software in an SDR portable allows the user to more quickly engage the RF band and the right channel within the band, and choose the appropriate air interface and the group affiliation. It presents these selections to the user in terms that can be easily understood. The benefit of SDR technology is increased when portable/mobile SDR equipment is used with an SDR-enabled system, employing a cross-networking interface. The SDR-enabled infrastructure brings all of the participants of the group into the call when this is desired, regardless of location, system, RF band, or the air interface they use.

Using SDR technology, public safety agencies could effectively achieve interworking communications across a broad range of systems, operating in different frequency bands and with different technologies. This challenge, and the approaches for addressing it, are being pursued internationally. SDR technology provides the potential for operation and interoperability across multiple radio-interface standards and bands of operation. This would enable interoperability and interworking among public safety agencies on multiple air interfaces, overlaying existing systems without disruption, upgrading legacy systems, including possible transition from one radio interface to another, and the easy selection of RF band, air interface, and group affiliation by users of portable SDR equipment.

When fully implemented, SDR could lower the total cost of ownership of public-safety wireless communication systems while also improving system responsiveness to interoperability issues.

9.3.1.2 Interoperability

Interoperability is the ability of equipment made by different vendors to work interchangeably with each other, which is important for PPDR applications. Interoperability can only be accomplished if all vendors build their equipment to the same harmonized standard. Here, again, SDR-based radio would be easier to build to multiple standards and modify, should a change be required. As PPDR communication systems evolve, many changes are anticipated and would be implemented, relatively easily, thanks to SDR technologies.

9.3.2 Enhanced functionality

Enhanced functionality for the user is also possible with SDR technology that uses computer software to generate its operating parameters, particularly those involving waveforms and signal processing. This is currently in use by some government agencies and in some radio equipment products. SDR systems would be capable of transmitting voice, video, and data, and have the ability to incorporate cross-banding to communicate, bridge, and route communications across dissimilar systems.

9.3.3 Remote control

SDR systems could be remotely controlled and may be compatible with new products and backward-compatible with legacy systems. By building upon a common open architecture, SDR systems could improve interworking and support interoperability by providing the ability to share waveform software between radios, even radios in different physical domains. Further, SDR technology could facilitate public protection organizations to operate in a harsh electromagnetic environment, to be less detectible by scanners, and to be protected from interference from sophisticated intentional interference and hacking. Additionally, an SDR-based system could replace a number of radios currently operating over a wide range of frequencies and allow interoperation with radios operating in disparate portions of that spectrum.

9.4 Intelligent transport systems (ITS) applications

Various kinds of radio services are provided to vehicles at present. This includes, for example, broadcasting services such as FM radio, TV, as well as ETC (electronic toll collection) services. VICS (vehicle information and communication system) are also provided in some regions.

In addition to these radiocommunication services, other land mobile services such as cellular phones and radio LANs are also used for ITS applications such as traffic and traveller information, and emergency call notification.

Other applications include crash avoidance technology which depends on a continuous, real-time understanding of the vehicle's driving environment. This understanding can clearly be enhanced and enlarged by using data derived from sources external to the vehicle, including land-based information centres and other vehicles. Real-time remote vehicle diagnostics depend on a similar data communications capability.

SDRs may become an essential component of future suites of in-vehicle technologies.

The clear trend for the delivery of ITS messages is that they will be data messages, not voice technology messages. They will be handled by a dedicated, and possibly integrated in-vehicle data communication unit (DCU) that is completely separate and isolated from the vehicle's multimedia system (that handles general information and entertainment services) and from any personal communication devices that link wirelessly to the multimedia system (e.g. via Bluetooth) or through a docking cradle.

The communication technologies through which ITS-related messages will be transmitted and received are evolving and will undoubtedly continue to evolve. A collection of umbrella protocols will allow for transparent in-vehicle data communications via a variety of wireless media, for example cellular data messages, short-range microwave, millimetre wave, mobile wireless broadband, two-way satellite, etc. This collection will be expanded and refined with the arrival of new technologies and the improvement of existing ones. Some technologies may fall out of use over time.

9.4.1 Space considerations

Due to space and radio environments peculiar to vehicles, SDR is a very useful and effective technology to realize a multi-mode mobile terminal to handle a variety of radio systems in a vehicle.

In a vehicle, interior space is a very important factor and ensuring that this space is safe and comfortable for drivers is an important design issue. SDR technology, which makes it possible to integrate several kinds of radiocommunication equipment into one radio device, can contribute to the effective use of interior space of the vehicle.

9.4.2 Power considerations

The application of SDR to vehicles is not impacted by the power consumption of the SDR equipment. In order to implement multiple-radio accessible functions into SDR equipment, large and high-speed digital devices are required, however, in vehicle use, batteries and an electric power generator mounted in the vehicle can be used as the power source for the SDR equipment.

9.4.3 Reconfiguration considerations

Static reconfiguration of SDR equipment may be executed in the event that an existing radio system is enhanced or a new radio system is added as part of a vehicle service. For such remodelling of equipment, an adequate amount of digital devices should be estimated in advance.

Dynamic reconfiguration is required for the “vertical handover” among multiple heterogeneous radiocommunication systems. In this case, the ability to complete the reconfiguration quickly is one of the key factors in the design of SDR equipment.

Dynamic reconfiguration of ITS mobile terminals is particularly important to enable interoperability among ITS services. These services and technologies could include satellite positioning, mobile communications and 5.8 GHz microwave technologies SDR-based on-board equipment designed to support all these possible services will enable users to avoid the need to have a multitude of on-board equipment within the vehicle.

Another issue to be considered is how to give SDR equipment the ability to handle multiple services simultaneously, that is, how to enable SDR equipment to process multiple radio services such as FM radio and ETC simultaneously. It is especially important to realize the road traffic safety and convenience of peer-to-peer and multipoint communication between vehicles and the roadside.

9.4.4 Service life considerations

Another key factor for the implementation of SDR in vehicles is the service life of private passenger cars which may exceed 12 years. The DCU must be functionally available for the entire service life of the vehicle. A significant burden is placed on in-vehicle SDRs’ ability to remain upgradeable over a significant time span, for example throughout many generations of RF technologies. For example, the probability of encountering an avoidable crash situation and the probability of a remotely diagnosable fault increase with the vehicle’s age. Therefore, the value of SDRs to remain upgradeable and reconfigurable increases in the later years of service. Advance planning and careful strategizing will be needed to enable a lifespan for in-vehicle SDRs that is far longer than non-vehicle radios. In-vehicle requirements imply the need for SDRs that are reconfigurable.

The physical longevity of the DCU is not the primary issue, although some steps may be needed to keep it in good working order. The important issue is for an aging DCU to be able to continue communicating through multiple generations of communication technology.

9.4.5 Cost considerations

The cost of maintaining the necessary longevity of the DCU can be significantly reduced by making the operating characteristics of the DCU software reconfigurable and remotely updatable, allowing it to adapt:

- a) to the mobile communication technologies currently available in the area that the vehicle is operating; and
- b) to changes in the characteristics and membership of this family of technologies.

9.4.6 Special requirements for SDR in the vehicle

Some specific capabilities for SDRs are necessary to assuring the widest possible continuing availability of these ITS services. The radios may include software-controlled antenna filters to

allow the use of new frequencies as they come online, and the software in in-vehicle SDRs must be kept up to date to the extent practical. This has two implications.

The first is that SDRs in vehicles should be capable of having their software updated and upgraded. The second is that this capability should be available for these radios without requiring physical maintenance (e.g. the replacement of a DSP or its 20-years-from-now equivalent). For vehicle manufacturers and vehicle equipment manufacturers as well as owners and drivers, updating of software will be more economical than physical component replacement. However, well-focused design and planning is required to make this capability available.

These requirements imply that the software for an in-vehicle SDR is not only updatable, but downloadable. It may be possible to transmit this software to the vehicle via the same mechanism used to deliver other ITS-related data messages – and the in-vehicle radio may be capable of receiving and installing these software updates.

These capabilities will maximize the ability of all equipped vehicles to communicate with one another and the infrastructure, and they will moderate the burden on the land-based communication utility to be infinitely backward compatible.

9.5 Amateur and amateur satellite systems

Operators in the amateur and amateur-satellite services have been utilizing SDRs in their stations since 1999. Amateur radio designers started with the idea that PCs could be used as SDRs. The concept was that an analogue-to-digital (A/D) converter would be used to translate radio frequencies to intermediate frequencies that could be accommodated by a PC. However, A/D converters are noisy, thus it was necessary in receivers to precede the A/D converter by a low-noise amplifier and low-pass filters. While there is some use of PCs to perform SDR functions, amateur designers generally chose to use soundcards and to develop dedicated SDR platforms.

9.5.1 Soundcard applications

Typical 16-bit PC soundcards have a maximum sampling rate of 44 100 Hz, meaning that the maximum bandwidth signal that can be accommodated is 22 050 Hz. Most soundcards have antialiasing filters that cut off at 20 kHz. With quadrature sampling, the sampling rate can be extended to 44 100 Hz. Some soundcards sample at 96 kHz.

Soundcards have been used as hardware platforms for development of audio-frequency modems for chat mode communications such as PSK31 and data transmission both narrow-band and voice frequency bandwidths. Other soundcard applications include audio frequency filters, spectrum analysers producing “waterfall” displays and noise reducers.

9.5.2 First-generation SDR transceiver

The first-generation amateur service SDR transceiver, was developed by an individual radio amateur in 1999. This DSP-based hardware platform was designed for operation only in the band 144-148 MHz. The SDR was capable of transmission and reception on several emission modes, including continuous wave (CW), single sideband (SSB) and frequency modulation (FM) voice.

The SDR was controlled by a laptop PC using DSP programs written in assembly language, approximately 2 000 words in length. Transceiver control is done via the PC keyboard.

9.5.3 Second-generation SDR transceiver

The second-generation SDR transceiver was developed in the 2002-2005 time-frame to cover amateur service bands in the frequency range up to 54 MHz. The second-generation SDR transceiver uses free software, in some cases under a general public licence. It is open software, meaning that different developers can contribute to the software and others may use it.

9.5.4 Third-generation SDR equipment

The years 2006 onward saw the development of numerous SDR devices for amateur service use, ranging from postage stamp size receivers to full featured complete transceivers.

In addition to commercially available SDR equipment marketed to amateur radio operators, the high performance software-defined radio initiative exists to develop modular, open source, SDR components.

9.5.5 Amateur-satellite SDR applications

Nearly all amateur satellites now being designed have some SDR functions. These permit software to be uploaded from earth telecommand stations to alter parameters of the satellites.

9.6 Other land mobile systems

Over the years, the development of better electronic equipment has allowed the channel spacing employed by the land mobile radio service to be decreased. Because of the need for backward compatibility, however, most of the land mobile radio services cannot take full, immediate advantage of the increased spectrum use for narrower channels. For example, legacy equipment does not have the capability to tune to the interstitial channels. Moreover, transition of these services from analogue to digital modulation techniques, which can support a more flexible and efficient use of the spectrum, has been difficult because of the backward compatibility requirement. SDR could facilitate this transition in channelization and modulation schemes in the land mobile radio service. By being able to switch modulation/detection schemes, to switch frequencies and bandwidths of operation, and possibly sense the characteristics of received signals and to institute actions based on these characteristics, SDR could operate in this transitional environment.

10 Technology aspects related to IMT systems

IMT systems may demand an extremely wide diversity of functionality and spectral flexibility, and may technically stretch the SDR technology to the limits of scientific knowledge.

As shown in Fig. 4, system update, smooth handover, roaming, interoperability, high-speed switching, miniaturization, and low power consumption are important areas in which SDR is may be a means to realize cost effectiveness.

This section describes how SDR might satisfy such requirements and consists of the present status of R&D and study items of related technologies to be developed in the future.

FIGURE 4

System and hardware aspects of SDR's impact on system requirements for IMT systems

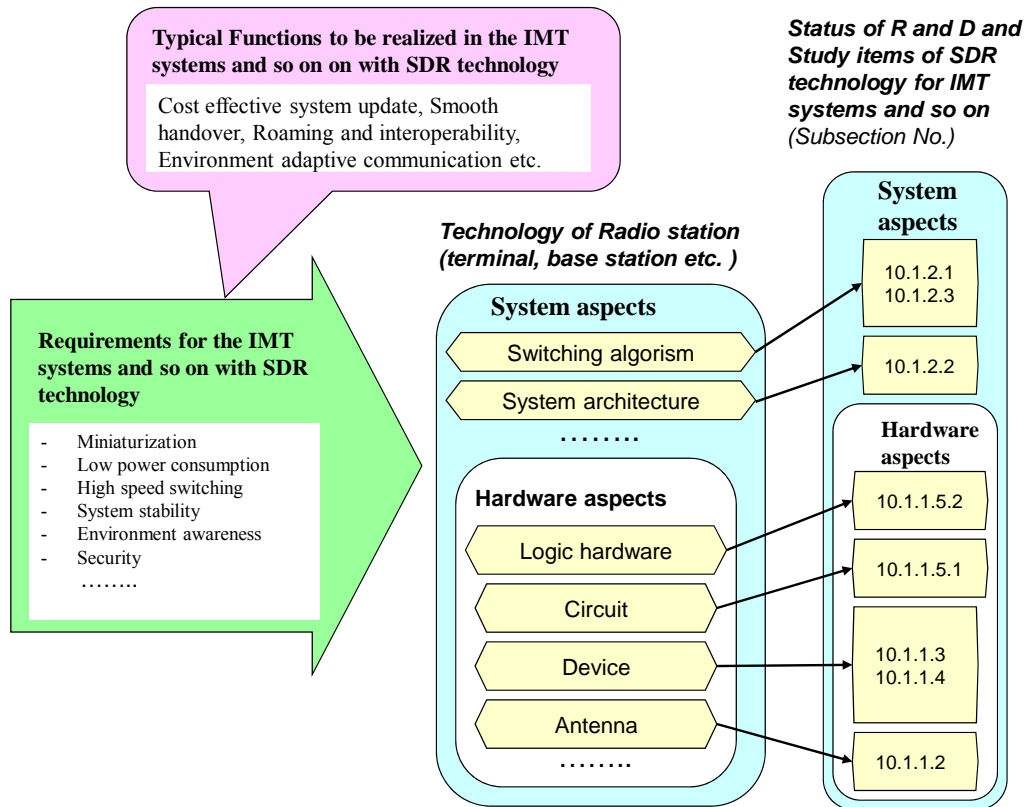

10.1 Status of R&D

There are several technologies that can contribute to the increasing realization of SDR's potential especially for IMT systems. The R&D status of these technologies categorized into the aspects of hardware and system are seen below.

It is envisaged that the use of software-defined radio in commercial wireless communication systems such as IMT systems will develop gradually as hardware, software and cost tradeoffs mature.

10.1.1 Hardware aspects

10.1.1.1 Hardware overview

Looking at an SDR terminal from a principal point of view the following figure can be drawn:

FIGURE 5

Basic architecture of SDR

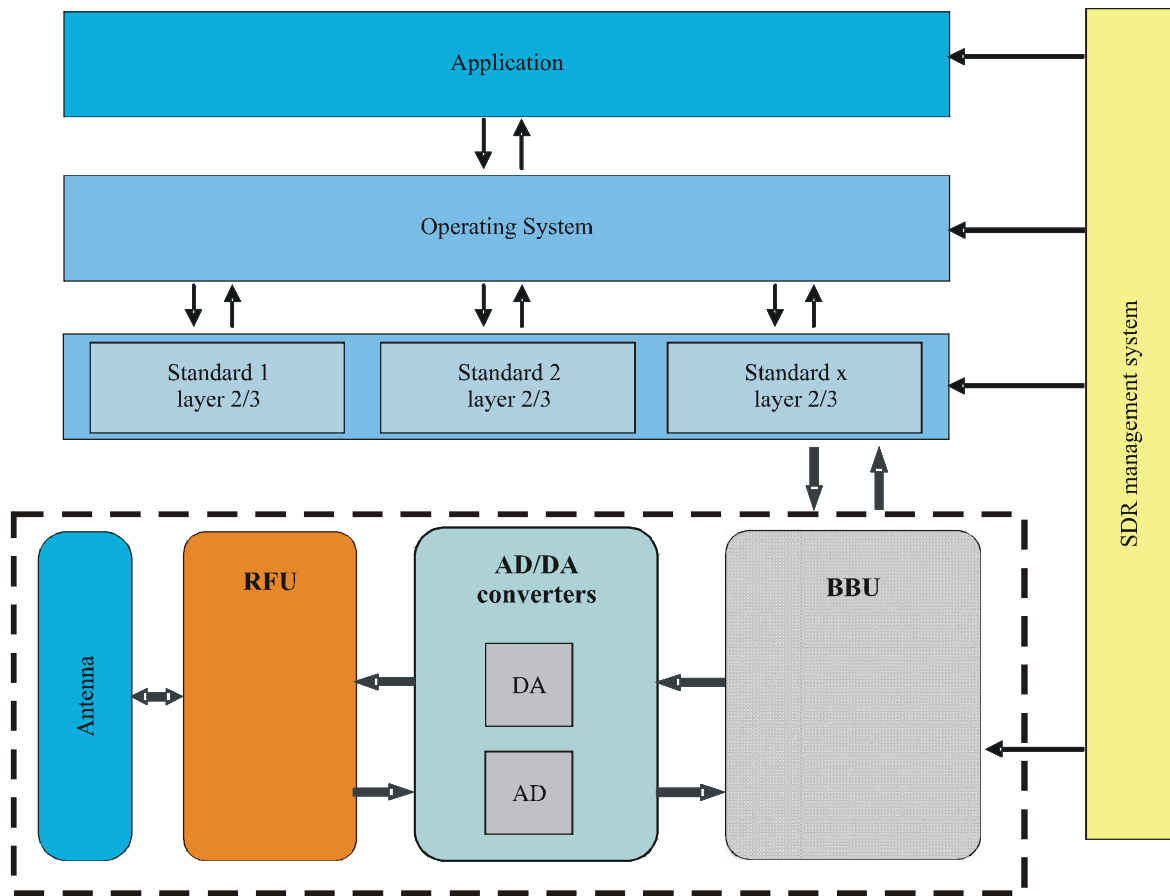

Rap 2117-05

Figure 5 shows the functional SDR hardware elements “Baseband unit (BBU)”, “Analogue-to-digital/digital-to-analogue (AD/DA) converter unit”, “Radio-frequency unit (RFU)” and the antenna system.

Within the RF-unit the receiver, transmitter and the front-end unit are comprised.

RFU may perform the frequency down-/up-conversion etc., for the frequency range needed to support IMT systems. BBU performs several functions such as high-speed signal processing (sampling rate conversion, filtering, etc.), modulation/demodulation for each system, transmission control, and modem control (reconfiguration function).

These hardware elements are standard independent, i.e. almost any air interface standard can be processed after the download of the respective software. The responsible entity for the proper and faultless implementation of a standard is the SDR management system. It is the central software component for SDR devices and has terminal-wide control of the SDR procedures, reconfigurations and transactions. This includes the device reconfiguration as well as management of the terminal resources. It also provides a high-level control interface for mode switching. The SDR management system has an interface to the BB unit.

10.1.1.2 Aspects of antenna systems

Future antenna systems are expected to support a wide range of frequencies. A small size antenna achieving wide bandwidth is essential to realize different radio access technologies in different bands in hardware, while it is challenging since the small size and wide bandwidth could contradict each other.

Furthermore, the antenna system should be capable of supporting parallel reception and transmission of different radio bands, where an optimum beamforming algorithm and a multi-user detection algorithm are essential. At present there are many research and development activities ongoing.

10.1.1.3 Radio-frequency unit (RFU)

In applying SDR to IMT systems, in order to correspond to multi-band/multi-mode communication systems, selecting RFU architecture suitable for SDR is very important. Moreover, circuits such as amplifiers and mixers that compose an RFU are required to have a broadband characteristic. Filters for reducing interference from other communication systems need to vary their passband corresponding to the frequency of a received signal.

10.1.1.4 Analogue-to-digital/digital-to-analogue (AD/DA) converters

In applying SDR to IMT systems, AD/DA converters are expected to require a 10 bits or higher resolution and 100 Msample/sec or higher sampling rate for SDR. The reason for 10 bits is that some potential new modulation schemes such as OFDM have large PAPR (peak-to-average power ratio). IMT-Advanced may have signal bandwidth of several tens of MHz, and over-sampling is required for baseband AD conversion. These figures need to be obtained with low power dissipation for battery-powered terminals.

If higher performances are required, major improvements not only on power dissipation of AD/DA converters but on precision (or jitter) of the clock source are needed.

10.1.1.5 Baseband unit (BBU)

In Fig. 6, the BBU performs several functions such as high-speed signal processing (sampling rate conversion, filtering, etc.), modulation/demodulation for each system, transmission control, and modem control (reconfiguration function).

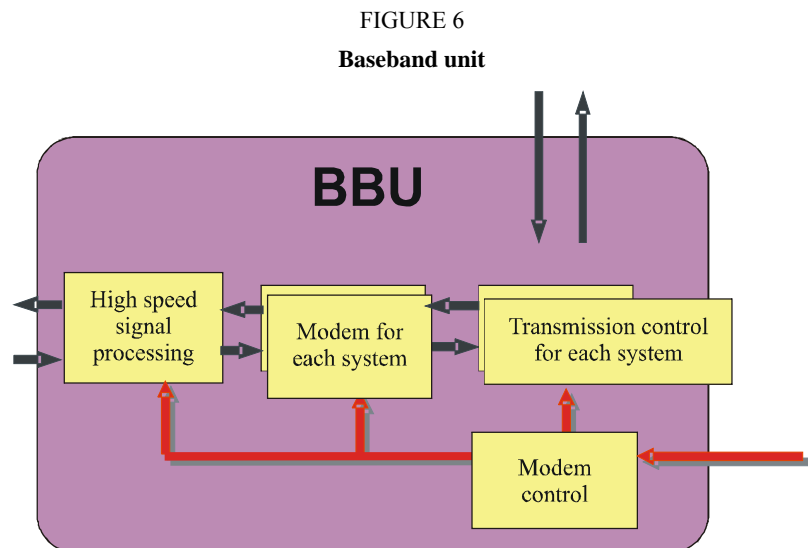

Rap 2117-06

10.1.1.5.1 Sampling rate conversion filter

In applying SDR to IMT systems, simultaneous reception of different radio access systems is required for multimode mobile terminals in case of inter-system handover, so the digital signal processing design of the terminals should be independent of the A/D sampling rate. Therefore a function that converts the sampling rate of the ADC output signals to a suitable one for modulation is needed between the ADC and the modulation unit.

10.1.1.5.2 Reconfigurable baseband processor

One of the biggest problems in achieving the digital baseband part with SDR applied to IMT systems is that the processing performance demanded of each generation of mobile telecommunications increases rapidly. Nearly one thousand times the processing power is required as compared with the previous generation of mobile communications.

The use of a hybrid architecture of the processor is significant, consisting of reconfigurable circuits with high and restricted flexibility for programming and dedicated hardware for common purposes, in order to achieve the high processing performance especially required in IMT-Advanced.

10.1.2 System aspects

10.1.2.1 High-speed software switching

The performance of switch software in SDR significantly depends on the devices to be used, such as DSP (digital signal processor), FPGA (field programmable gate array) and others. For example, a system using DSP may be reconfigured relatively easily and switched at high speed. When FPGA is used in the system, the switching time is longer than for DSP because FPGA currently must be fully reconfigured whenever the system is switched. Some technologies will reduce the switching time like multiple FPGAs used as a cache.

10.1.2.2 Simultaneous multiple communication

Especially for IMT systems, simultaneous multiple communications may be a necessary function of SDR terminals. As the number of radiocommunication systems implemented in one terminal increases there is a point at which SDR clearly has advantages of body size, cost and flexibility of system update. Items for further study include how to store each system's software and how to realize simultaneous communication. For example in some case the entire software of each system may be downloaded, in others a common part of the software may be shared among the systems.

10.1.2.3 Communication system selection

A user with an SDR-based terminal may have the possibility of selecting a wireless system that best meets his or her requirements. Thus, a way to identify a user's requirements is crucial. Some information to define the requirements can be obtained in the terminal, and some other information cannot. Examples of the former information are the received signal strength indicator (RSSI), bit error rate (BER), frame error rate (FER), transmission power consumed for each system, and the number of transistors and gates in the digital signal processing unit. The latter information may be transmission speed, charge of usage and data reliability. All this information may be used to select and switch the systems.

10.2 Items for future study

The following technologies may be required to study items for SDR in IMT systems. Several technologies are being developed to a certain extent as shown in previous § 10.1. There are technical items that should be further studied and developed as follows. Study items regarding software download including over-the-air software download are described in § 6.

To assist in applying SDR to IMT systems, the development of technology for the hardware element is encouraged as follows:

- Further development of analogue signal processing devices such as antenna, RFU, AD/DA converters further. Especially for terminals, miniaturization or low power consumption are needed. Furthermore, software controlled frequency band-switching or multiband characteristics without hardware switching are required for the multi-mode/multiband terminal.

- With regard to baseband processing devices, such as baseband processors, although the complexity depends on the type of radio systems, very high performance will be necessary, while the mobile communication system will become large-scale and highly advanced in the future. Furthermore, stability improvement, and especially for terminals, low power consumption are future study items.

Examples of specific study items

- **Adaptive antennas and RFUs:** Programmable multiband antennas and RFUs are expected to satisfy the requirement for several frequency bands in IMT systems. The technical specification of transmission power, spurious emissions, sensitivity etc. need further study as well.
- **Tuneable filters with steep attenuation characteristics:** To study the challenge of achieving a very steep attenuation characteristic for the filters in the RFU, especially, in the duplexer for separating the transmit and receive signals.
- **High-speed ADC/DAC with wide dynamic range:** SDR requires high-speed semiconductor devices, and deep sub-micron CMOS technology is suitable. Such devices operate with low power supply voltage, and the low supply voltage limits the dynamic range of the analogue part. ADCs with low supply voltage and high resolution (i.e. wide dynamic range) should be studied especially.
- **High performance baseband processors:** To realize inter-system handover, baseband processors must handle baseband processing of both systems at the same time. Baseband processors require very high processing capabilities and high-speed task-switching capabilities.
- **System switching and inter-system handover:** Examples of study items are development of system architecture, further high-speed real-time OS, commonly used software description language and development of adaptation method in response to the radio environment. Especially for the mobile terminals, simultaneous miniaturization and low power consumption are necessary.
- **Environment adaptive communication:** To achieve lower power consumption of terminal equipment, a technique which can adaptively vary the communication algorithm according to the communication environment is necessary.

Annex A

Technical aspects related to IMT systems

1 Aspects of antenna systems

1.1 Monopole antenna using human body

Although small size and multiband characteristics are mutually exclusive in general, this antenna can achieve both of them [Fukasawa and Ohtsuka, 2003]. This antenna is a monopole antenna using the human body as a ground plane (Fig. 7). The radiation element is a ground plane of internal circuits. So, by using only a small conductor contacted with the human hand, this antenna does not require the conventional resonance element with a quarter wave length.

FIGURE 7
Monopole antenna using human body

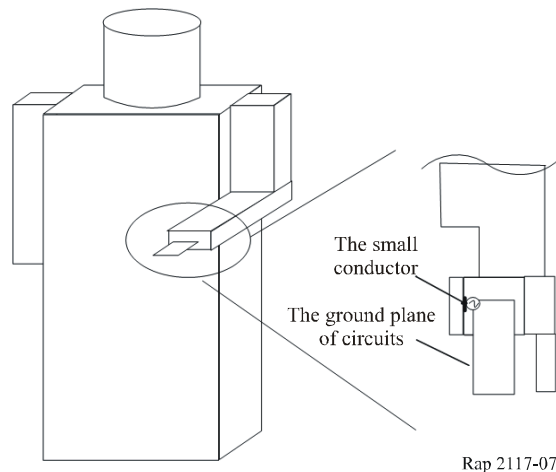

Rap 2117-07

This antenna can achieve very wide bandwidth available for multi-band use. For example, a voltage standing wave ratio (VSWR) < 3 for 0.5 to 2.5 GHz (Fig. 8) and efficiency of more than -4 dB (Fig. 9) are obtained.

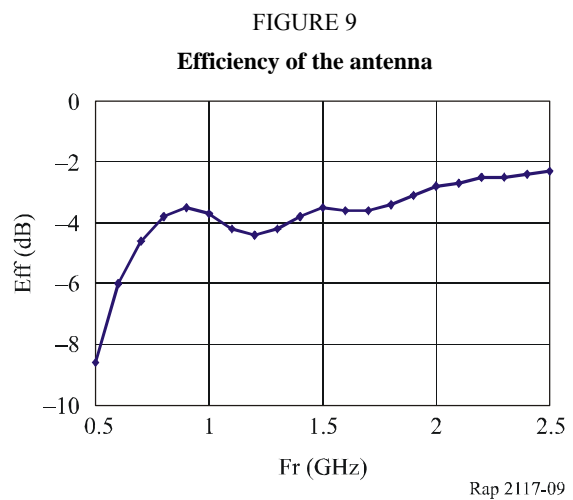
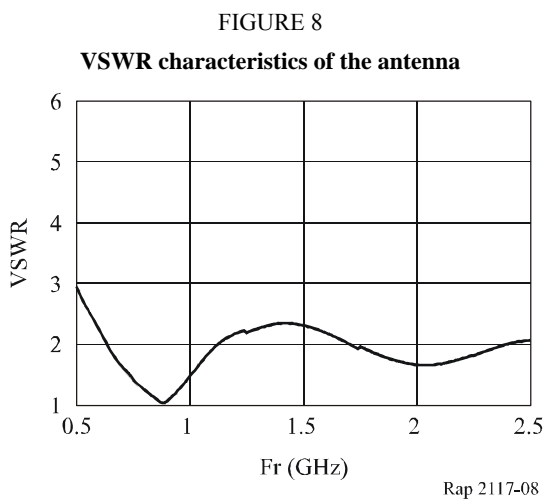

1.2 Software adaptive antenna

A software adaptive antenna takes advantage of the space diversity of the time-varying propagation environment by using the optimum multi-antenna algorithm. To implement the algorithm, the adaptive antenna system has to change adaptively with respect to the time varying fading environment. The software adaptive antenna implementation discussed here overcomes the limitations of each individual algorithm by employing channel recognition, modulator/demodulator, calibration unit, multi-antenna algorithm pool, system controller and SDR network, etc. Therefore, in a sense, this software adaptive antenna can sense the environment at any time. The architecture of a software adaptive antenna is shown in Fig. 10.

FIGURE 10

Architecture of software adaptive antenna

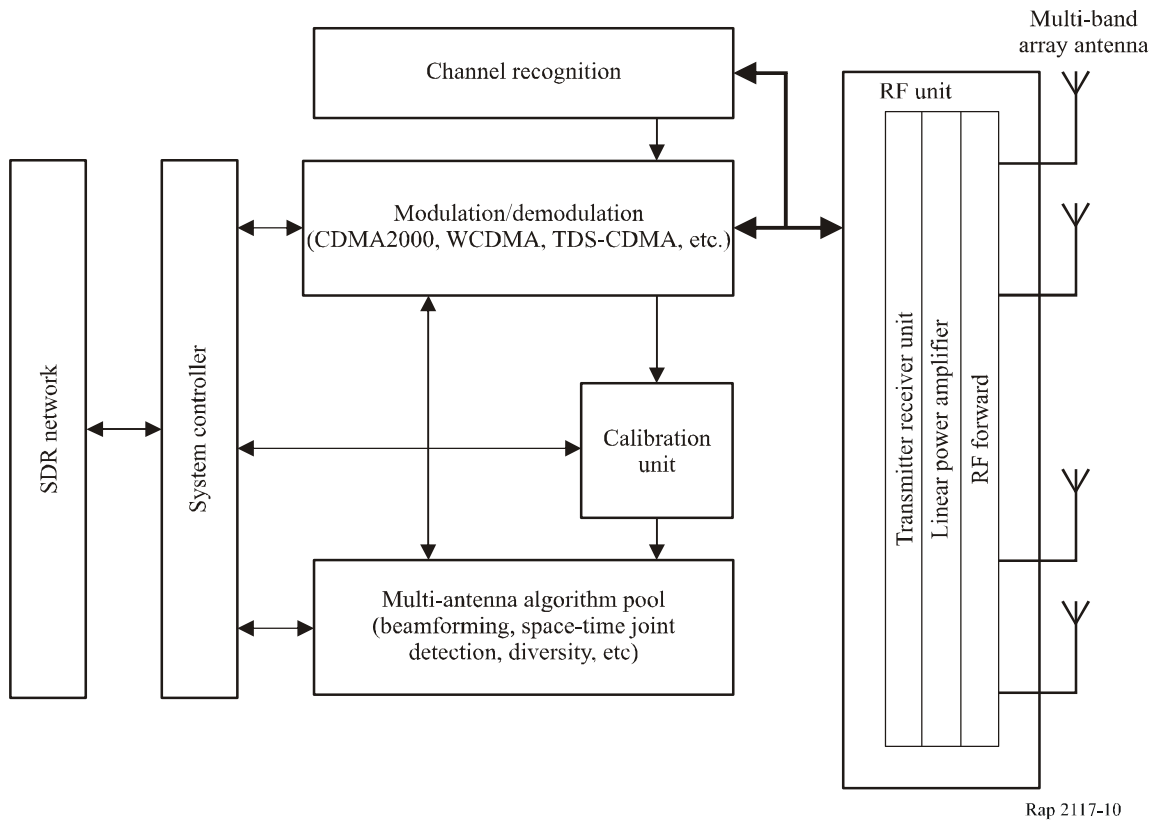

1.2.1 Application of IMT systems software adaptive antenna system

The technology overcomes the shortcoming of the traditional adaptive array antenna algorithm which is limited in its area of use. It adopts software adaptive antenna technology so that the system can be used in a multifarious environment.

1.2.1.1 Software adaptive antenna in IMT-2000 CDMA direct spread

An example is shown of the implementation of software adaptive antenna used in IMT systems for mobile communication. Specifically, Fig. 11 is a schematic illustration of the software adaptive antenna for IMT-2000 CDMA direct spread systems. The inputs are baseband signals that come from the antenna elements and after A/D conversion. With the input data, it is able to estimate the numbers of desired signal, delay spread, spatial spread, and in-band spectral power, etc. Using the estimated values, the software adaptive antenna can select the beamforming algorithm and determine the multiple user detection (MUD) algorithm. Therefore, with the desired beam directed to the expected user and suppressing the interferences, the software adaptive antenna can increase the possible capacity of the cellular system and improve the quality of the wireless communication in low-SNR environments as well.

It comprises:

- A function for evaluating changes in the environment and identifying interferences.
- A pool of beamforming algorithms for a variety of possible countermeasures, and a function for finding the optimum beamforming algorithm at any time.
- MUD by the results of environment sensing and recognition.

FIGURE 11
Configuration of software adaptive antenna in IMT-2000 CDMA direct spread

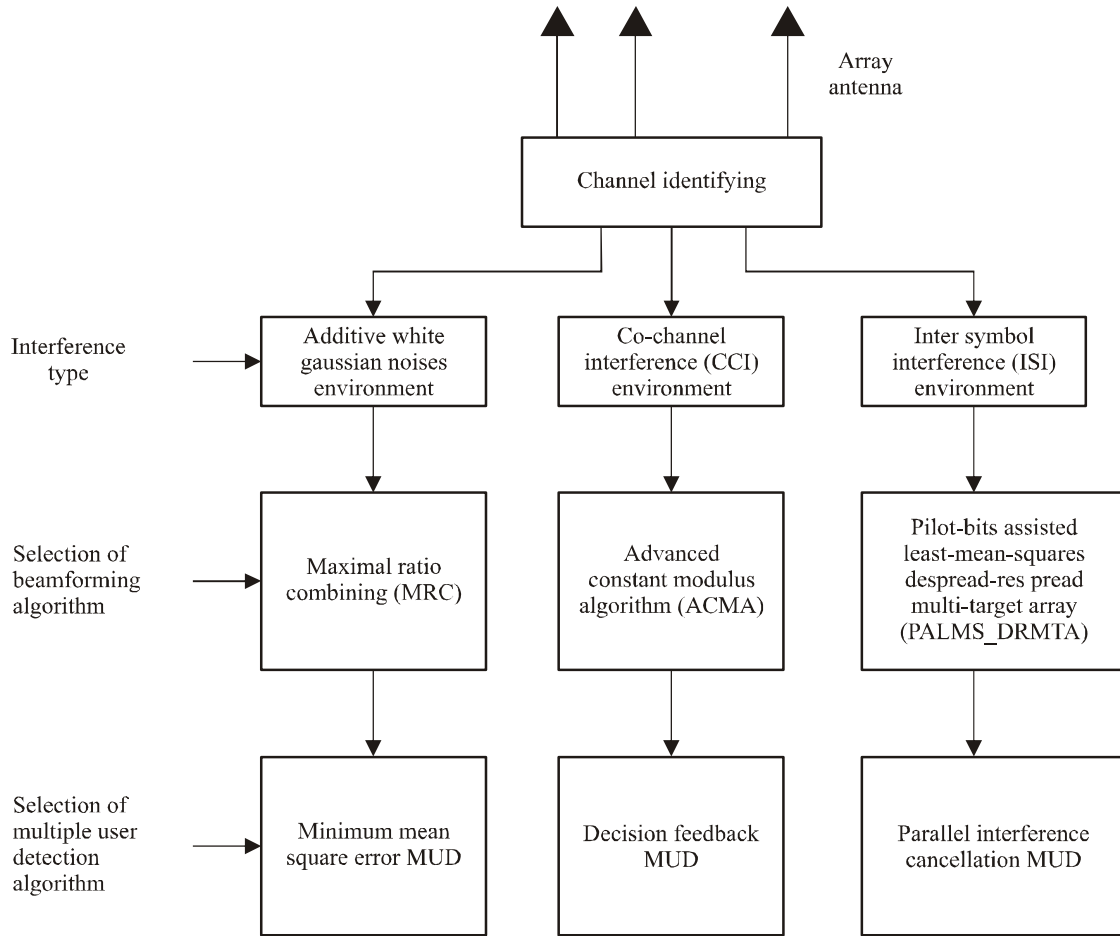

Rap 2117-11

1.2.1.2 Software adaptive antenna in IMT-2000 CDMA TDD

Figure 12 is the configuration of software adaptive antenna for TD-SCDMA, which has the function of runtime reconfiguration by means of an adaptive algorithm based on radio environmental recognition in space and time.

FIGURE 12

Configuration of software adaptive antenna in TD-SCDMA

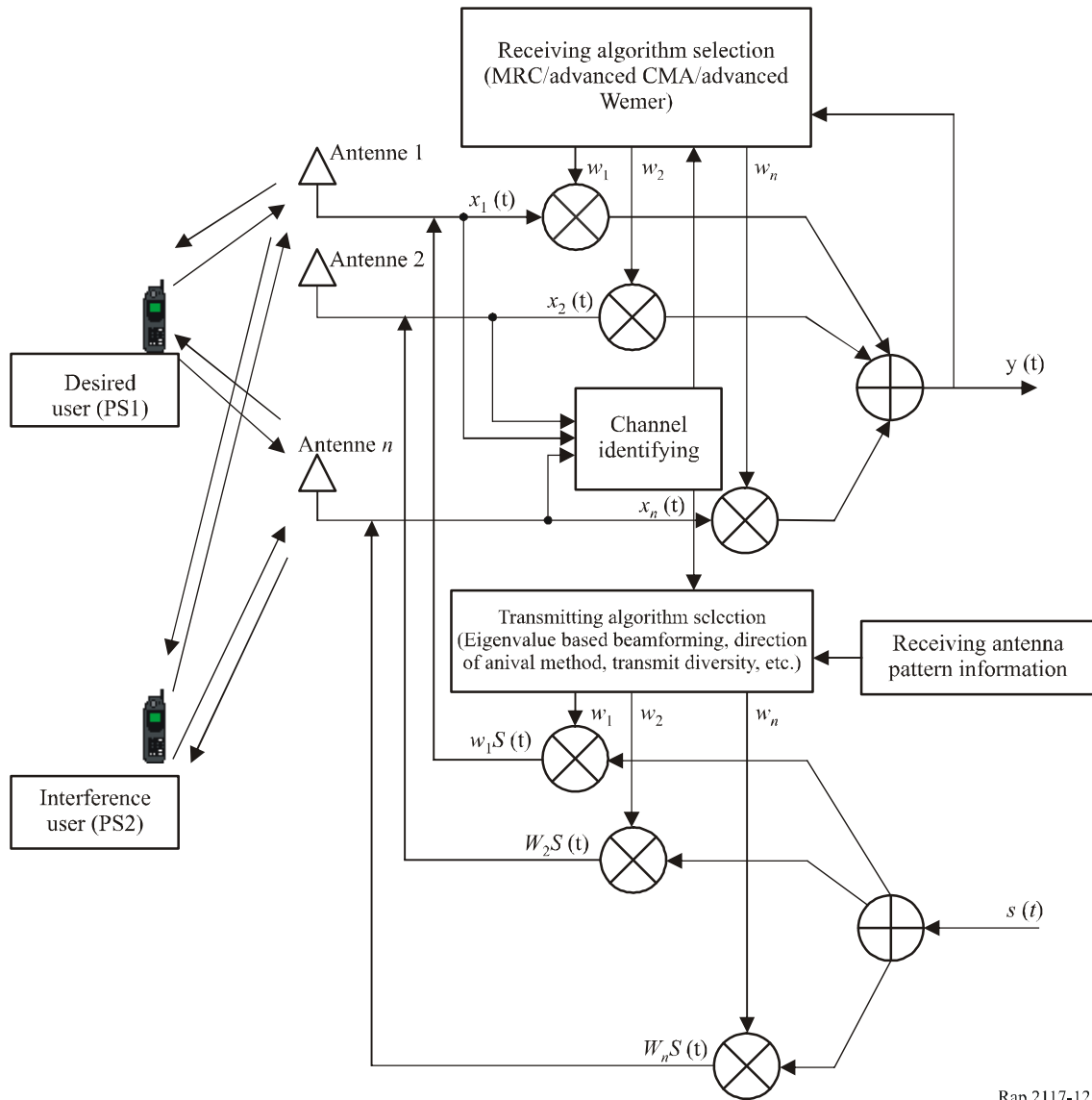

Rap 2117-12

1.2.1.3 Software adaptive antenna in IMT-2000 CDMA multi-carrier

Figure 13 is the configuration of software adaptive antenna for IMT-2000 CDMA multi-carrier.

FIGURE 13

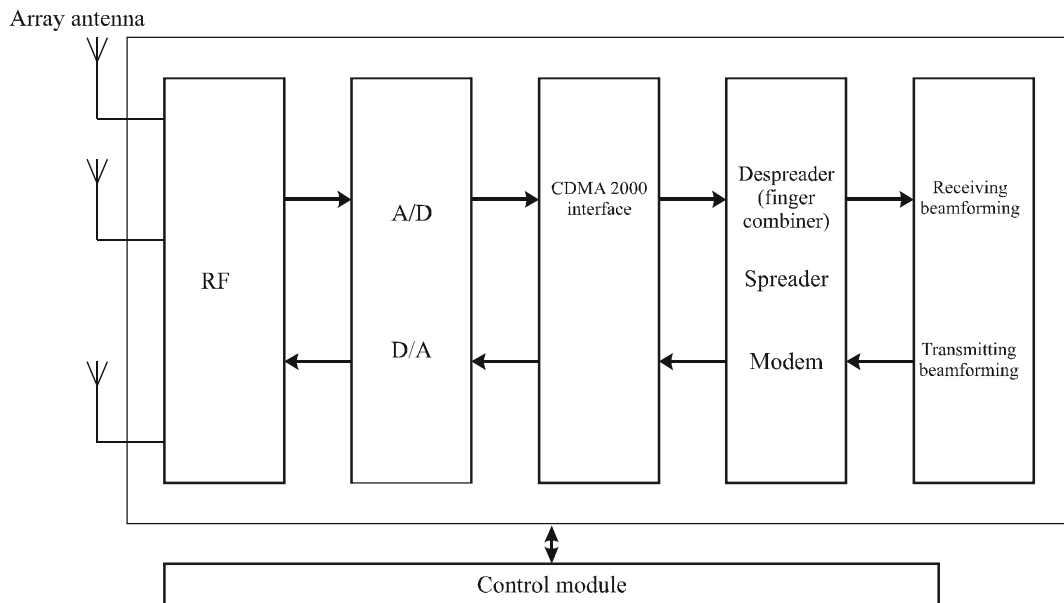
Configuration of software adaptive antenna in IMT-2000 CDMA multi-carrier

Rap 2117-13

1.3 RFU

In order to correspond to multiband/multi-mode communication systems, selecting an RFU architecture suitable for SDR is very important. A direct conversion architecture (Fig. 14) that can achieve miniaturization is chosen as the receiver architecture [Kawashima *et al.*, 2002], since an image rejection filter and IF band-filter becomes unnecessary. The direct modulation architecture is very promising since this can simplify composition to the transmitter. However, it is necessary to perform transmitting power control with a large dynamic range. Composition examination including power control at a local signal of a quadrature modulator is performed.

Circuits, such as a low noise amplifier (LNA), an RF quadrature mixer and a driver amplifier that compose an RFU, are required to have a multiband characteristics. With a multiband RF quadrature mixer for a direct conversion receiver, achievement of good amplitude and phase balance is difficult. To improve the accuracy, a 90° phase shifter employing a divider circuit is currently proposed. In order to reduce the interference from other communication systems, the receiving RF filter needs to vary its passband corresponding to the frequency of a received signal. With a high-power amplifier (HPA), all of the frequency bands are not covered by a single device, but efficiency of the HPA is improved by using two or more devices.

FIGURE 14

Direct conversion architecture

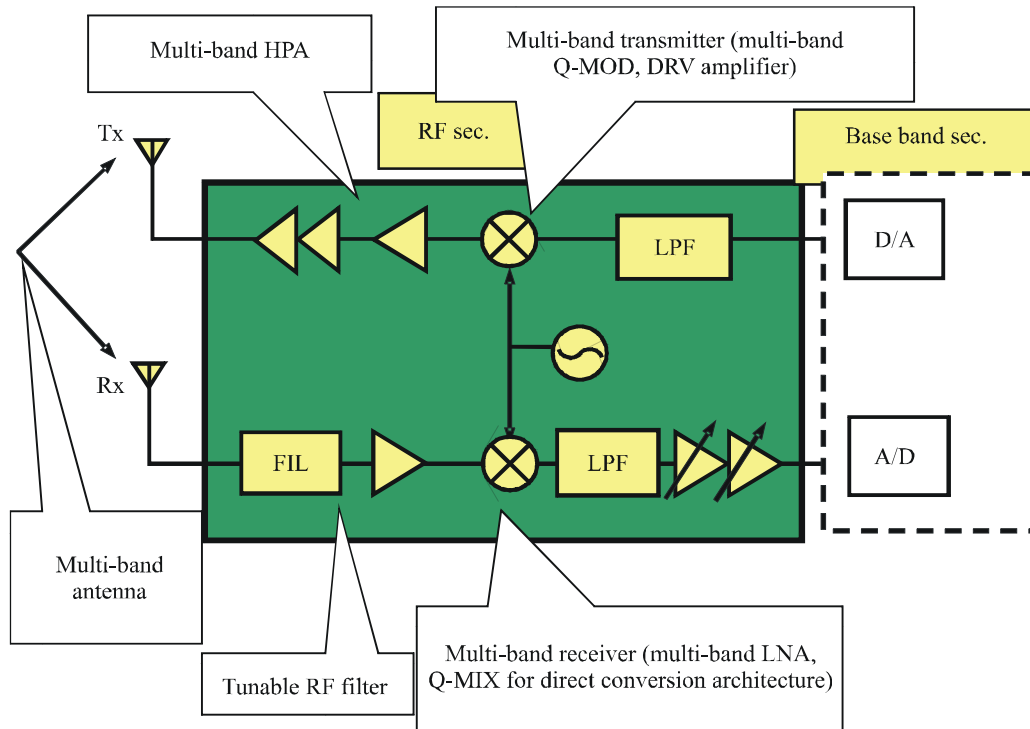

Rap 2117-14

1.4 AD/DA converters

In applying SDR to IMT systems, AD/DA converters are expected to require a 10 bits or higher resolution and 100 Msample/s or higher sampling rate for SDR. The reason for 10 bits is that some potential new modulation schemes such as OFDM have a large PAPR (peak-to-average power ratio). IMT-Advanced may have a signal bandwidth of several tens of MHz, and over-sampling is required for baseband A/D conversion. These figures need to be obtained with low power dissipation for battery-powered terminals.

If higher performances are required, major improvements not only in power dissipation of the AD/DA converters but also in the precision (or jitter) of the clock source are needed, as discussed in [Walden, 1999]. Figure 15 is the reported ADC data plot, and shows that the aperture jitter limits the SNR for the target sampling frequency range.

FIGURE 15

Reported ADC performance

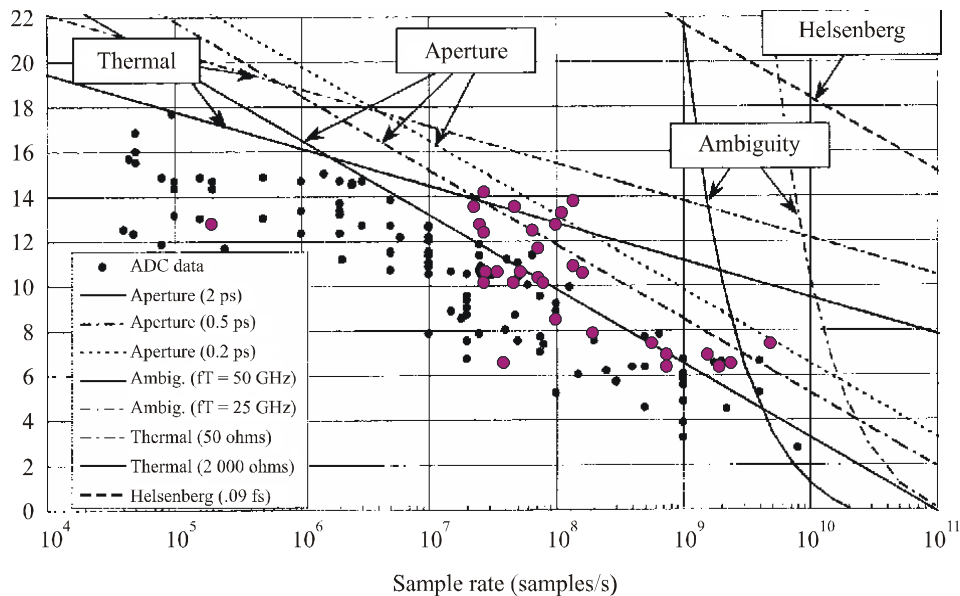

Note 1 – This figure is based on the paper by Walden (1999)

Note 2 – The additional data plotted with ● in the figure are taken from the papers at the IEEE International Solid State Circuits Conferences (ISSCC) '99-'02

Rap 2117-15

1.5 Sampling rate conversion filter

As mentioned earlier, simultaneous reception of different radio access systems, as in the case of inter-system handover, is needed so digital signal processing design of the terminals should be independent of the A/D sampling rate. Therefore the function that converts the sampling rate of the ADC output signals to a suitable one for the modulation is needed between the ADC and the modulation unit.

Figure 16 shows an implementation example of a sampling rate conversion filter for multi-radio access technology (RAT) mobile terminals [Motoyoshi *et al.*, 2003]. This filter is implemented by use of a delay time-variable pulse-shaping filter with a polynomial approximation technique [Farrow, 1988] and is intended to perform pulse-shaping signals and sampling rate conversion at the same time. The sampling rate conversion ratio can be finely controlled only by controlling delay-time of the filter without changing the filter's structure or coefficients.

FIGURE 16

Implementation example of sampling rate conversion filter

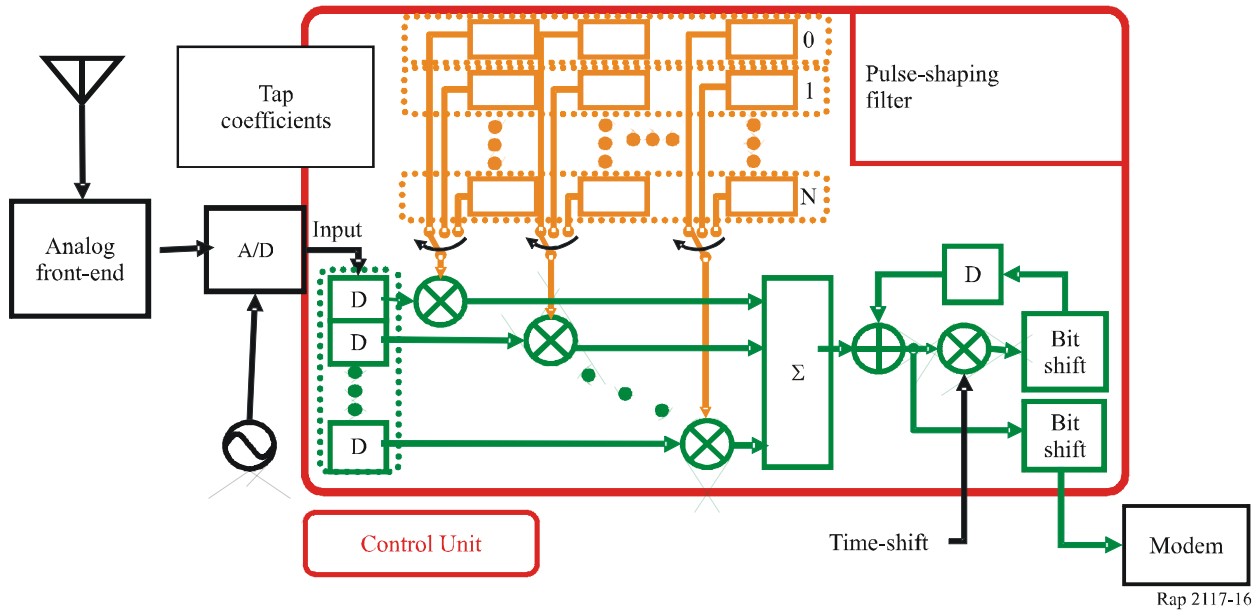
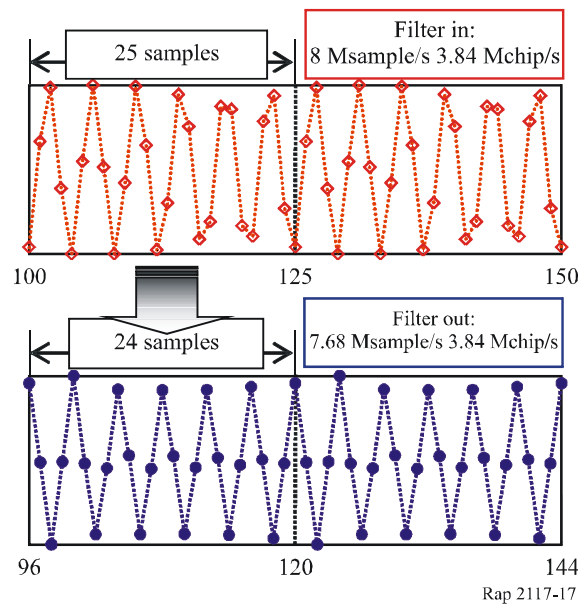

Figure 17 shows an example of how the filter works. The graph at the top of Fig. 17 shows the A/D output of an IMT-2000 CDMA Direct Spread signal sampled at 8 Msample/s, which is not an integral multiple of the chip rate (3.84 Mchip/s). The graph at the bottom of Fig. 17 shows the output of the filter. In this filter, the sampling rate of the input signal is converted from 8 Msample/s to 7.68 Msample/s, which is 2 times the chip rate.

FIGURE 17

Example of sampling rate conversion filter behaviour



By use of the filter, one can obtain an optimum sampling rate for modulation. Moreover, this process is not so heavy for terminals because this can be shared with the digital pulse-shaping process usually needed for single-carrier RAT systems, which need less processing power than high-speed RAT systems (e.g. OFCDM) relatively.

1.6 Reconfigurable baseband processor

One of the biggest problems in achieving the digital baseband part for SDR applied to IMT systems is that the processing performance demanded of each generation of mobile telecommunications increases rapidly. For IMT-Advanced, transfer rate increases from 384 kbit/s to 100 Mbit/s and the introduction of new techniques such as MIMO will require more than 1 000 times the processing power compared with former generations.

On the other hand, the processing performance of processors executing baseband processing is increasing with a growth rate a little less than Moore's law: namely 4 times per every 3 years.

The growth rate of processor performance is lower than that of the baseband processing requirement.

An approach that provides all the baseband processing only by DSPs is not realistic. An approach that provides the baseband processor by a combination of restricted flexibility circuits with the complementary functions corresponding to the characteristics needed for baseband processing becomes important.

In other words, for realization of SDR, a LSI circuit that has a hybrid architecture consisting of the following components may be necessary:

- arrays of processing elements such as ALUs (arithmetic logical units) which achieve a high degree of programmability;
- special purpose reconfigurable circuits (or parameterized hardware) that achieves higher processing performance by restricting the flexibility of programmability;
- dedicated hardware such as general purpose CPU's or memories.

Commonly used functions such as FFT are candidates for parameterized hardware that can economically realize a matched filter and a decoding function. It may be more advantageous to achieve the function with dedicated hardware and give flexibility to apply it also for other uses than to achieve the functionality with a complex, processing element array from the perspective of circuit area (i.e. cost) and power consumption. The architecture of a reconfigurable baseband processor for SDR is shown in Fig. 18. It uses several arrays of processing elements to execute processing which requires higher programmability, and several parameterized hardware elements to execute a commonly used function or functions which require very high processing performance. The number of processing element arrays or kind of the parameterized hardware changes according to the wireless communication systems to be realized as SDR.

FIGURE 18

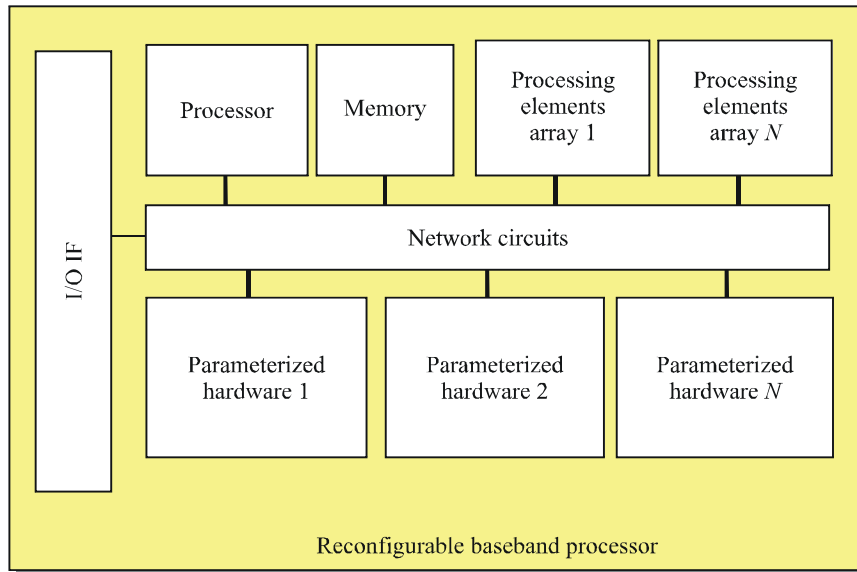
Reconfigurable baseband processor architecture

Rap 2117-18

1.7 High-speed software switching

The performance of switch software in SDR depends significantly on the devices to be used, such as DSP (digital signal processor), FPGA (field programmable gate array) and others. For example, systems using DSP may be reconfigured relatively easily and switched at high speed. When an FPGA is used in the system, switching time is longer than for DSP because FPGA currently must be fully reconfigured whenever the system is switched. Some technologies will reduce the switching time, like multiple FPGAs used as a cache.

Figure 19 shows one concept where a communication functionality block is programmed into the reconfigurable digital signal processing hardware units, and a desired modulation/demodulation scheme can be selected by only the parameter information. An experimental prototype has confirmed feasibility of the technology in which it was possible to change the modulation/demodulation scheme among ASK, QPSK, BPSK, GMSK, and $\pi/4$ QPSK in less than 1 ms [Kawashima *et al.*, 2002 and Walden, 1999]. The communication functionality block is a common core module (CCM) for all of communication systems, however there are some parts that are dependent on communication systems in the software.

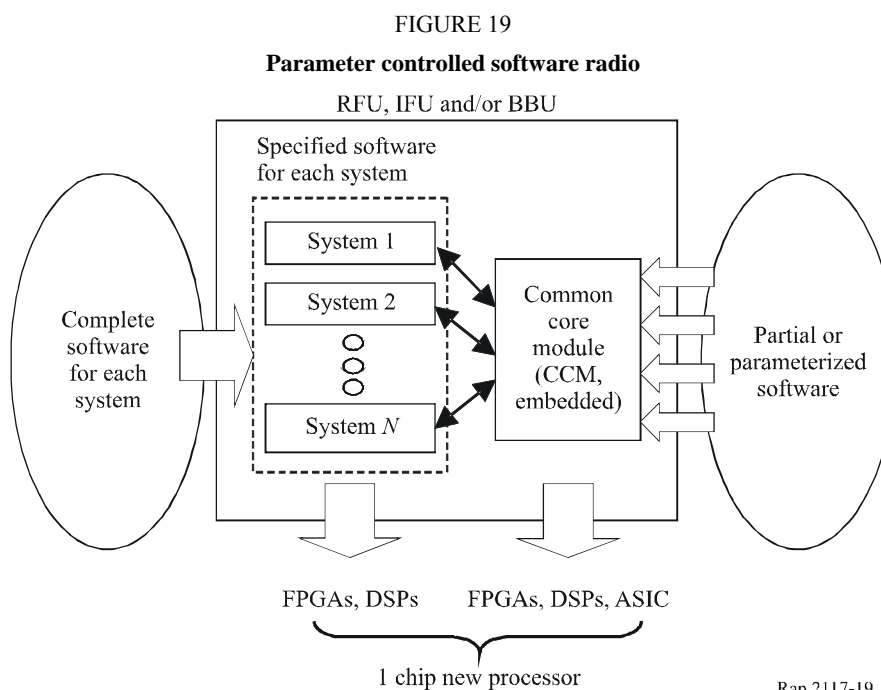

1.8 Simultaneous multiple communication

Especially for IMT-2000, simultaneous multiple communications may be a necessary function of SDR terminals. As the number of radiocommunication systems implemented in one terminal increases there is a point at which SDR clearly has advantages of body size, cost and flexibility of system update.

Shown in Fig. 20 is an example of a typical implementation of simultaneous multiple communication. In the future multi-mode and multi-service terminal, the RFU (radio-frequency unit), IFU (intermediate frequency unit) and BBU (base band digital signal processing unit) will be connected via a multi-port junction circuit. The RFU and IFU must cover as wide a bandwidth as possible. The BBU comprises a single or several hardware units for digital signal processing. Software to implement two or more communication systems is downloaded on demand to the hardware units for digital signal processing by the BBU using multi-mode and multi-task software radio (MMSR) technology [Harada and Fujise, 2002 and Harada, 1999]. All of the software may be downloaded individually, as shown in Fig. 20a). Otherwise, as shown in Fig. 20b), part of the software may be shared among the systems in the processing to implement multiple systems.

FIGURE 20

Examples of system architecture for simultaneous multiple communication

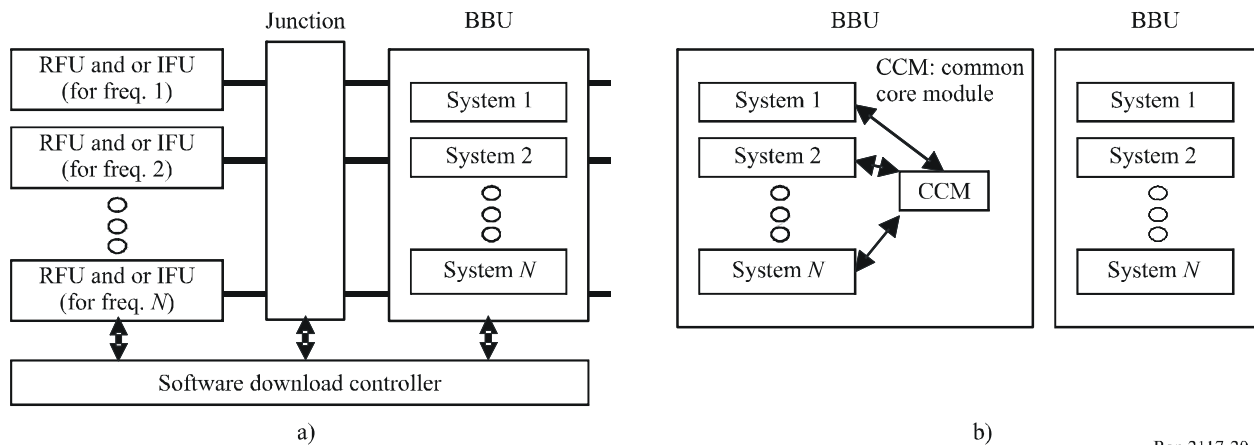

Rap 2117-20

1.9 Communication system selection

A user with an SDR-based terminal may have a possibility of selecting a wireless system that best meets his or her requirements [Farrow, 1988]. Thus, a way to identify a user's requirements is crucial. Some information to define the requirements can be obtained in the terminal, and some other information cannot. Examples of the former information are the RSSI, BER, FER, and transmission power consumed for each system. The latter information may be transmission speed, price (charge of usage) and data reliability. In Fig. 21a), systems are evaluated in terms of speed, price, and reliability. Figure 21b) shows the priorities needed in the entire communication process using this terminal, before starting communications. While communicating, information on RSSI, BER, or FER is obtained at the terminal, as shown in Fig. 21c), where the vertical axis represents lower values of RSSI, BER or FER. If a value falls below the first threshold, the operability of the other services is checked. The check result may be obtained by measuring RSSI of other communication systems. If the second threshold is passed, there should be a change. To change systems, the systems are prioritized based on the information shown in Fig. 21a) and Fig. 21b). A system is selected according to the priority.

FIGURE 21

Example of communication system selection

a)

	<i>Speed</i>	<i>Price</i>	<i>Reliability</i>	<i>Other</i>
<i>W-CDMA</i>	<i>7</i>	<i>5</i>	<i>7</i>	<i>0</i>
<i>IEEE802.11a</i>	<i>9</i>	<i>7</i>	<i>7</i>	<i>0</i>
<i>PHS</i>	<i>5</i>	<i>9</i>	<i>7</i>	<i>0</i>
<i>Other</i>	<i>5</i>	<i>5</i>	<i>5</i>	<i>0</i>

b)

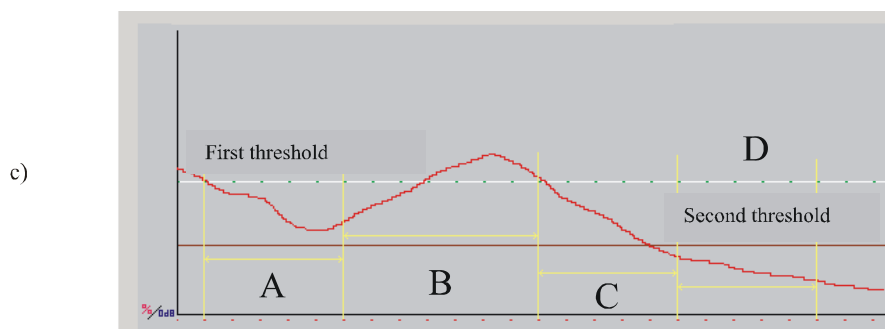

Rap 2117-21

References

- FARROW, C. W. [June 1988] A continuously variable digital delay element. Proc. IEEE Int. Symp. Cir. and Sys., Vol. 3.
- FUKASAWA, T. and OHTSUKA, M. [2003] The monopole antenna using human body as a ground plane. Commun. Society Conf. of IEICE, B-1-189.
- HARADA, H. [September 1999] A proposal of multi-mode and multi-service software radio communication systems for future intelligent telecommunication systems. Proc. WPMC'99, p. 301-304.
- HARADA, H. and FUJISE, M. [December 2002] A new small-size multimode and multi-task software radio prototype for future intelligent transport systems. IEICE Trans. Commun., Vol. E85-B, 12, p. 2703-2715.

- KAWASHIMA, M. NAKAGAWA, T. HAYASHI, H. NISHIKAWA, K. and ARAKI, K. [December 2002] A 0.9-2.6 GHz broadband RF front-end chip-set with a direct conversion architecture. *IEICE Trans. Commun.*, Vol. E85-B, 12, p. 2732-2740.
- MOTOYOSHI, K. AOYAGI, T. and MURAKAMI, K. [March 2003] Digital pulse-shaping with sample rate conversion for 4G SDR UE. *Proc. 2003 IEICE Gen. Conf.*
- WALDEN, R. H. [April 1999] Analog-to-digital converter survey and analysis. *IEEE J. Selected Areas in Comm.*, Vol. 17, 4, p. 539-550.

Bibliography

- HARADA, H. and FUJISE, M. [March 1998] Multimode software radio system by parameter controlled and telecommunication toolbox embedded digital signal processing chipset. *Proc. IEICE Gen. Conf. 98*, B-5-83.
- HARADA, H. KAMIO, Y. and FUJISE, M. [June 2000] Multimode software radio system by parameter controlled and telecommunication component block embedded digital signal processing hardware. *IEICE Trans. Commun.*, Vol. E83-B, 6, p. 1217-1228.
- HARADA, H. KURODA, M. MORIKAWA, H. WAKANA H. and ADACHI, F. [December 2003] The overview of the new generation mobile communication system and the role of software-defined radio technology. *IEICE Trans. Commun.*, Vol. E86-B, 12.
- YODA, K. NISHIJIMA, S. KONDO, S. SAITO, M. ISHIHARA, T. and HIROSE, Y. [2003] The study of semi-fixed hardware element for software-defined radio. *Commun. Society Conf. of IEICE*, B-5-60.

Annex B

External organizations

Several international and industrial fora, standards development organizations and industry consortia are currently working on SDR related topics, e.g. flexible, reconfigurable terminal/base station software architectures, and security mechanisms for software download.

Some of these bodies are described here.

Industry consortia and IMT interaction

Wireless Innovation Forum

An international non-profit organization dedicated to promoting the development, deployment and use of SDR technologies for advanced wireless systems:

- Wireless Innovation Forum addresses different aspects of an SDR system such as market, technical and regulatory topics. It has established formal liaison activities with standardization development organizations such as the 3GPP and OMA. More detailed information is provided at <http://www.wirelessinnovation.org>.

The Open Mobile Alliance (OMA)

The mission of the Open Mobile Alliance is to facilitate global user adoption of mobile data services by specifying market driven mobile service enablers that ensure service interoperability across devices, geographies, service providers, operators, and networks, while allowing businesses to compete through innovation and differentiation.

- OMA developments of specifications regarding security mechanism (e.g. OMA wireless public key infrastructure), rights management (OMA digital rights management) or device management for terminal configuration are related to SDR implementation. More detailed information is provided at www.openmobilealliance.org.

The third generation partnership Project (3GPP)

The scope of 3GPP includes producing globally applicable technical specifications and technical reports for a 3rd generation mobile system based on evolved GSM core networks and the radio access technologies that they support (i.e. universal terrestrial radio access (UTRA) both frequency division duplex (FDD) and time division duplex (TDD) modes).

Technical Specification Groups (TSG) develop specifications on various technical aspects in areas such as:

- “Core network and terminals (TSG CT)”
- “Service and system aspects (TSG SA)”
- WG 3 Security – responsible for the security of the 3GPP system
- “Radio access network (TSG RAN)”.

More detailed information is provided at www.3gpp.org.

The third generation partnership Project 2 (3GPP2)

Provides a collaborative third generation (3G) telecommunications specifications-setting project comprising North American and Asian interests developing global specifications for ANSI/TIA/EIA-41 Cellular radio telecommunication intersystem operations network evolution to 3G and global specifications for the radio transmission technologies (RTTs) supported by ANSI/TIA/EIA-41.

Technical specification groups (TSG) develop specifications on various technical aspects in areas such as:

- TSG-A (Access network interfaces)
- TSG-C (cdma2000®)
- TSG-S (Services and systems aspects)
- TSG-X (Core networks).

More detailed information is provided at www.3gpp2.org.

IEEE standards association (SA)

Information on IEEE SA is provided at standards.ieee.org/sa/index.html. There are currently three P1900.x working groups and one study group within the standards coordinating committee 41 (SCC41, “Dynamic spectrum access networks (DySPAN)”) structure related to SDR – more detailed information on SCC41 is provided at [//www.scc41.org/](http://www.scc41.org/):

IEEE P1900.1 Working Group

Document title – Standard definitions and concepts for dynamic spectrum access: terminology relating to emerging wireless networks, system functionality and spectrum management.

IEEE P1900.2 Working Group

Document title – Recommended practice for interference and coexistence analysis.

IEEE P1900.3 Working Group

Document title – Recommended practice for conformance evaluation of software-defined radio (SDR) software modules.

IEEE Study Group A: the aimed standard will specify test and analysis methods to be used when assessing whether the spectrum access behaviour of a radio system with dynamic spectrum access capability complies with specified limits, standards or rules. Radio system design features that simplify the evaluation are also specified.

More detailed information for the IEEE P1900.1, P1900.2, and P1900.3 Working Groups is provided at standards.ieee.org/board/nes/approved.html.

Research projects and initiatives

Various research projects and initiatives which impact SDR technology development are:

- European end-to-end-reconfigurability project (E²R).
 - E²R is an integrated project addressing the core of the strategic objective “Mobile and wireless systems beyond 3G”. The key objective of the E²R project is to devise, develop and trial architectural design of reconfigurable devices and supporting system functions to offer an expanded set of operational choices to the users, application and service providers, operators, regulators in the context of heterogeneous mobile radio systems. More detailed information is provided at www.e2r2.motlabs.com.
- High performance software-defined radio (openHPSDR).
 - Open HPSDR is an open source (GNU type) hardware and software project intended as a “next generation” software-defined radio (SDR) for use by radio amateurs. It is being designed and developed by a group of SDR enthusiasts with representation from interested experimenters worldwide, including amateur radio licensees. More information is provided at www.openhpsdr.org.

Examples of successful cooperation between different industry players in the area of modular base station architecture are:

Common public radio interface (CPRI) initiative

The common public radio interface (CPRI™) is an industry cooperation aimed at defining a publicly available specification for the key internal interface of radio base stations between the radio equipment control (REC) and the radio equipment (RE):

- CPRI specifications are freely available. More detailed information is provided at www.cpri.info.

The open base station architecture initiative (OBSAI)

Aims to create an open market for cellular base stations. An open market will substantially reduce the development effort and costs that have been traditionally associated with creating new base station product ranges:

- OBSAI is comprised of over a hundred companies, spanning base station manufacturing, module manufacturing and component manufacturing. More detailed information is provided at www.obsai.org.
-