

# **Report ITU-R F.2323-2**

**(09/2023)**

F Series: Fixed service

## **Fixed service use and future trends**



## Foreword

The role of the Radiocommunication Sector is to ensure the rational, equitable, efficient and economical use of the radio-frequency spectrum by all radiocommunication services, including satellite services, and carry out studies without limit of frequency range on the basis of which Recommendations are adopted.

The regulatory and policy functions of the Radiocommunication Sector are performed by World and Regional Radiocommunication Conferences and Radiocommunication Assemblies supported by Study Groups.

## Policy on Intellectual Property Right (IPR)

ITU-R policy on IPR is described in the Common Patent Policy for ITU-T/ITU-R/ISO/IEC referenced in Resolution ITU-R 1. Forms to be used for the submission of patent statements and licensing declarations by patent holders are available from <http://www.itu.int/ITU-R/go/patents/en> where the Guidelines for Implementation of the Common Patent Policy for ITU-T/ITU-R/ISO/IEC and the ITU-R patent information database can also be found.

### Series of ITU-R Reports

(Also available online at <https://www.itu.int/publ/R-REP/en>)

Series	Title
<b>BO</b>	Satellite delivery
<b>BR</b>	Recording for production, archival and play-out; film for television
<b>BS</b>	Broadcasting service (sound)
<b>BT</b>	Broadcasting service (television)
<b>F</b>	<b>Fixed service</b>
<b>M</b>	Mobile, radiodetermination, amateur and related satellite services
<b>P</b>	Radiowave propagation
<b>RA</b>	Radio astronomy
<b>RS</b>	Remote sensing systems
<b>S</b>	Fixed-satellite service
<b>SA</b>	Space applications and meteorology
<b>SF</b>	Frequency sharing and coordination between fixed-satellite and fixed service systems
<b>SM</b>	Spectrum management
<b>TF</b>	Time signals and frequency standards emissions

*Note: This ITU-R Report was approved in English by the Study Group under the procedure detailed in Resolution ITU-R 1.*

Electronic Publication  
Geneva, 2023

© ITU 2023

All rights reserved. No part of this publication may be reproduced, by any means whatsoever, without written permission of ITU.

## REPORT ITU-R F.2323-2

**Fixed service use and future trends**

(Questions ITU-R 253/5)

(2014-2017-2023)

**Scope**

This Report provides guidance on the future development of the fixed service (FS) taking into account evolution of current use and technology development, application trends for fixed wireless systems and future requirements for fixed wireless systems.

**Keywords**

Fixed service, fixed wireless access system, FWS technology trend, transport (trunking) network, mobile backhaul network, electronics news gathering, low latency microwave application, large/massive MIMO

## TABLE OF CONTENTS

	<i>Page</i>
1 Introduction .....	2
2 FWS use in telecommunication networks .....	3
2.1 Transport networks .....	4
2.2 Mobile backhaul networks.....	5
2.3 Fixed wireless access (FWA) systems.....	6
2.4 Temporary FS .....	7
2.5 Low latency microwave applications .....	8
3 FWS band usage .....	9
3.1 General consideration .....	9
3.2 Spectrum use in each band .....	10
3.3 Spectrum use in specific regions .....	13
3.4 Sharing and compatibility studies with other services .....	21
3.5 FWS regulatory regimes .....	22
4 FWS technology and trends.....	24
4.1 FWS technologies .....	24
4.2 Antennas .....	29
4.3 Further evolutionary scenario .....	35
4.4 Gigabit millimetric-wave links .....	37

	<i>Page</i>
4.5 Propagation considerations .....	39
4.6 Future technologies.....	40
5 Spectrum aspects and requirements.....	41
5.1 Evolving deployment scenarios .....	42
5.2 Capacity and spectrum requirements.....	43
5.3 Spectrum assignment and economical impact on small cells FS backhauling ...	44
6 Future subjects for the development of FWS applications.....	44
6.1 Applications.....	44
6.2 Band usage.....	45
6.3 Technologies.....	45
7 Conclusions .....	46
Annex 1 – Applications making use of FWA technology .....	46
Annex 2 – Example System using the IR technology described in section 4.4.2.....	52
Annex 3 – Example of field-trial on 18 GHz System using MIMO (Spatial Frequency Reuse) described in section 4.3 .....	54
Annex 4 – Experiments on large/massive MIMO technologies applied to FWSs.....	56
Annex 5 – Experiments on 42-GHz-band system for 8K UHD TV broadcasting auxiliary service.....	59
Annex 6 – Experiments on VHF (60 MHz) system for connecting rural areas.....	64

## **1 Introduction**

Significant recent and ongoing increases in data traffic have led to the requirement by users and network operators for network services capable of supporting very high data rates. Broadband fixed service (FS) is one practicable way to fulfil that requirement, because FS technology has that capability and is expected to play an important role to provide high quality broadband communication services through high-capacity fixed wireless systems (FWS)<sup>1</sup>.

FWS have evolved over the years and there is continuing evolution in terms of both technologies and applications. This Report offers guidance and information on the medium and long-term vision for the FWS, including key drivers and trends; it will greatly assist administrations, manufacturers, and telecom operators in their operative planning.

---

<sup>1</sup> The definition of FWS is specified in Recommendation ITU-R F.592.

This Report addresses the following items in relation to the future development of FS:

- FWS use in telecommunication networks including the following application:
  - Transport or trunking networks;
  - Mobile backhaul networks;
  - Fixed wireless access (FWA)<sup>2</sup> system;
  - Temporary networks;
- FWS band usage;
- FWS technology and trends;
- Spectrum requirements;
- Future subjects for the development of FWS applications.

## 2 FWS use in telecommunication networks

FWS are used in telecommunication networks in various situations. As shown in Fig. 1, FWS are used for transport networks (trunking, multi-hop, long-haul connections), for mobile backhaul networks, for FWA systems and for temporary networks.

Typical FS system parameters for the above applications (except for temporary use) in various frequency bands are summarized in Recommendation ITU-R F.758.

In the 1990s, the use of FWS found a major market requirement in the backhaul for mobile phone systems and for private network systems. Since the 2000s, the demand for the mobile backhaul further increased rapidly in many parts of the world because of the far-reaching proliferation of mobile phones.

The attractive features of FWS compared with wired systems are as follows:

- independence from geographical features, such as mountains and archipelagos;
- short-term system implementation period at low cost;
- robustness against disasters and other incidental disruption.

These features of FWS have contributed to fast and large-scale network deployments with the aim of quickly acquiring mobile phone subscribers, which has been a major economic factor in the rapid growth of the market for FWS.

---

<sup>2</sup> The definition of FWA is specified in Recommendation ITU-R F.1399.

FIGURE 1  
Various applications of fixed wireless systems

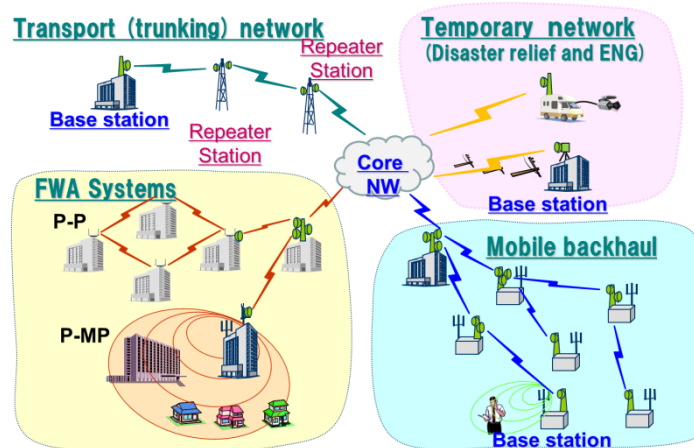

## 2.1 Transport networks

### 2.1.1 Trunking networks

Traditional trunking networks for long-haul or inter-exchange in telecommunications infrastructure networks typically operate in frequency bands in the range below 15 GHz. With the increase in traffic demand<sup>3</sup>, many service providers are now deploying fibre optic networks rather than build new very-high-capacity radio-relay networks. Although this is observed mostly in highly populated areas where major towns are connected by highways that facilitate the fibre optic deployment alongside, there are still areas where it is difficult to deploy fibre optic networks for geographical or economic reasons or it is economically convenient to upgrade already existing long-haul trunk infrastructures with more spectral efficient equipment. In such cases, radio-relay-networks continue to play an important role.

Quadrature Amplitude Modulation (QAM) modulation techniques up to 256-levels are currently adopted for transport networks according to the FWS parameters listed in Recommendation ITU-R F.758. Lower modulation level techniques such as 16-QAM or QPSK enable FWS to be applied to transmission links with a longer hop distance which may be required in areas such as far offshore islands.

### 2.1.2 Long distance transmission for connecting rural areas

Another use of transport network using FWS is to provide communication services to rural areas where long distance transmission is usually required, thanks to its deployment advantages similar to those described in § 2.1.1. Such rural areas are separated by geographic obstacles as depicted in Fig. 2, in some cases. For long distance transmission with FWS, frequency bands lower than UHF are suitable even if the payload capacity is limited by the narrow bandwidth available (e.g. up to about 300 kbit/s, for providing voice and internet to small and remote areas as in Fig. 2, otherwise connectable only via satellite. Among the lower frequency bands, very high frequency (VHF) band may be very attractive due to reasons as follows:

- stable radio propagation conditions not requiring a large fade margin against multipaths or precipitations;
- enabling communication in the environments of non-line-of-sights due to geographic obstacles such as mountains utilizing low diffraction loss of this frequency band compared to higher frequency.

<sup>3</sup> For example, traffic levels higher than SDH STM-1.

On the other hand, for such long distance transmission, reflected radio waves with long delay may arrive. To mitigate effect of reflected waves, multi carrier technologies such as orthogonal frequency division multiplexing (OFDM) are used. However, in the lower frequency bands, only narrow bandwidth is available compared with the higher frequency range and so an equalizer may be used instead of OFDM technologies. In addition, for long distance transmission, a situation such that only reflected waves are received may occur since there may be no line-of-sights between antennas of a transmitter and receiver due to geographical obstacles such as mountains. Under such situation that only reflected waves are received, in some cases, power of the first radio wave is stronger than power of delayed radio wave (i.e. minimum-phase) and in other cases, power of delayed radio wave is stronger than the first radio wave (non-minimum-phase), where an equalizer is required to adapt these situations. Experiment results of example of such a system are shown in Annex 6.

FIGURE 2

FWS for long distance transmission under NLoS for connecting rural areas

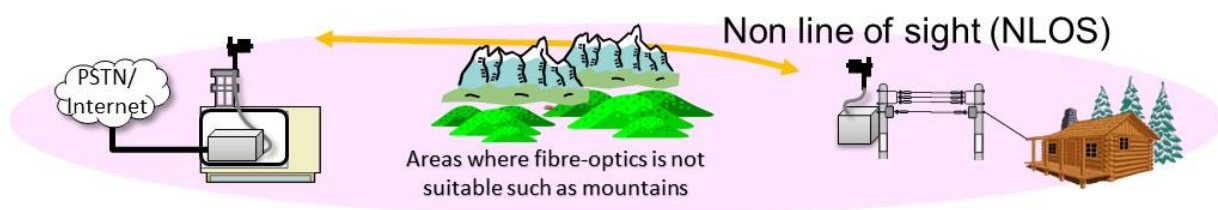

## 2.2 Mobile backhaul networks

Mobile backhaul networks are undergoing a transformation due in large part to increasing data volumes by mobile terminals. This increase is mainly the result of the introduction of so-called “smart phones” and in many cases the adoption of flat rate pricing plans (i.e. fixed prices with no upper limit on the amount of data communications traffic). Report ITU-R M.2243 refers to UMTS Forum Report 44 that forecasted worldwide mobile traffic of more than 127 Exabytes (EB) in 2020, which represents a 33 times increase compared with that in 2010. According to this Report, Asia will represent 34.3% of total worldwide mobile traffic while Europe and the Americas (including North, Central and South America) will represent 22% and 21.4%, respectively. To support this increase in the amount of data per mobile terminal, it has been necessary to reduce the cell radius of mobile base stations (BS). The reduction of cell radius has, in turn, resulted in pressures to reduce the cost and physical size of mobile BS and associated backhaul equipment.

The survey conducted by the ECO of CEPT/ECC on current use of FWS in Europe and reported in ECC Report 173 provides evidence for increasing provision of very high capacity systems for mobile backhaul. These very high capacity links can provide a viable alternative to deploying fibre optics, especially in rural areas, and equally in high-density urban areas where it would be not physically or economically feasible to deploy fibre optic or where there would be severe disruption caused, for example, by digging up roads to lay down fibre.

A consequence of these trends has been an increased use of new higher frequency bands by FWS for shorter distances since higher frequencies are associated with wider bandwidths, higher capacity and smaller antenna dimensions. For example, the bands from 42 to 52 GHz are newly employed in addition to existing frequency bands below 40 GHz. There is also increasing interest in the 60 GHz (57-64 GHz), 70 to 80 GHz (71-76 GHz and 81-86 GHz), as well as in 92 to 114.5 GHz and 130 to 174.8 GHz bands.

Reflecting this tendency, ITU-R Recommendations on RF channel arrangements have been developed for these high frequency bands, e.g. Recommendations ITU-R F.2005, ITU-R F.2006; Recommendation ITU-R M.2003<sup>4</sup> describes typical gigabytes RLAN applications that may need point-to-point outdoor (roof-to-roof buildings links) Fixed LAN Extensions (FLANE) described in ECC Report 114 and ECC/REC(09)01 (see Table 1 in § 3.2 below).

In access networks including mobile communications, downlink traffic capacity requirements (from BS towards subscribers) is generally higher than the uplink. Therefore, asymmetric frequency assignment plans are considered in some mobile applications. This point may affect future frequency assignment plans for FWS providing mobile backhaul networks in various frequency bands.

In order to achieve gigabit per second class capacity for FWS for mobile backhaul, several technologies have been introduced for commonly available frequency bands from 6 to 40 GHz, including very high order modulation, adaptive modulation, radio-link aggregation, polarization multiplexing and line-of-sight MIMO. It is also reported that applying these technologies to the higher bands from the newly available 42 GHz to those in the 50-55 GHz range or to the even wider channels of in the 70/80 GHz frequency bands would make it possible to achieve backhaul capacities approaching 10 Gbit/s and 40 Gbit/s [1].

ITU-R has developed Report ITU-R F.2393 which provides how the FS can be used in support of IMT and other mobile broadband to support the different hierarchical levels of the transport network of IMT systems, taking into account the above new technologies.

As IP (Internet protocol)-based techniques spread up in core networks, the requirements for FWS used in mobile backhaul are progressively updated in the aspect of the interface to the core networks and to mobile BSs.

In the next generation of mobile systems such as IMT-2020<sup>5</sup> whose framework and overall objectives are specified in Recommendation ITU-R M.2083, cell sizes of a BS are expected to be smaller. About 5 to 20 small cells are expected to be deployed for every current macro cell BS [2]. Consequently, a greater number of BSs (small cells) will be required, with consequent higher demand for backhauling connections; some could use FO likely available (but to the curb) in urban area, but a number of them would still benefit of quick and cost effective deployment of fixed radio technology. The capacity of the macro BS backhauling links may need to grow greater than 10 Gbit/s. In order to meet the requirement for next generation of mobile backhaul, many more broadband short-distance FWS links will be required.

It is important to note that, standing the large number of small cells BS, with very limited covering range and of relatively low power, also their cost objective, for an effective business case, will be significantly lower than that of present size BS technology. Consequently, also the backhauling cost objective (both from equipment and frequency use rights point of view) should comparably be reduced.

### 2.3 Fixed wireless access (FWA) systems

FWA systems are intended to provide connections between a network station (network access point) and terminal stations (end-user terminations) whose both locations are fixed. FWA systems are categorized as either P-P or P-MP according to their topology as depicted in Fig. 3. In P-MP systems, a single central station can provide coverage to a number of terminal stations although requiring

---

<sup>4</sup> Recommendation ITU-R M.2003 addresses multiple gigabit wireless systems in the Mobile service for typically indoor/nomadic RLAN-like access.

<sup>5</sup> The term “IMT-2020” is defined in Resolution ITU-R 56.



higher gain antenna and/or higher transmission power of terminal stations compared with P-P systems to achieve the same hop distance. As demand for data and video telecommunications increases and these telecommunications links require a much higher data rate than voice, FWA systems are also adopting broadband services. Moreover, the demand for broadband telecommunications is currently rising all over the world and FWA systems are superior to wired systems for providing broadband telecommunications economically and quickly in regions where the telecommunications infrastructure is not well developed. FWA systems operating in higher bands (e.g. above 17 GHz) may be able to provide broadband data rates similar to fibre to the home (FTTH) service on account of the wide bandwidth available in these frequency bands.

Other applications may be included in the definition of FWA specified in Recommendation ITU-R F.1399, these are considered as extensions of FWA and might be realised with equipment derived, in same or appropriate close-by bands, from the relevant mobile backhauled technology:

- Bridging two local/private area networks between separate buildings.
- P-MP backhaul.
- Links for machine-to-machine type communication.
- Home networks.

Examples of these applications are shown in Annex 1.

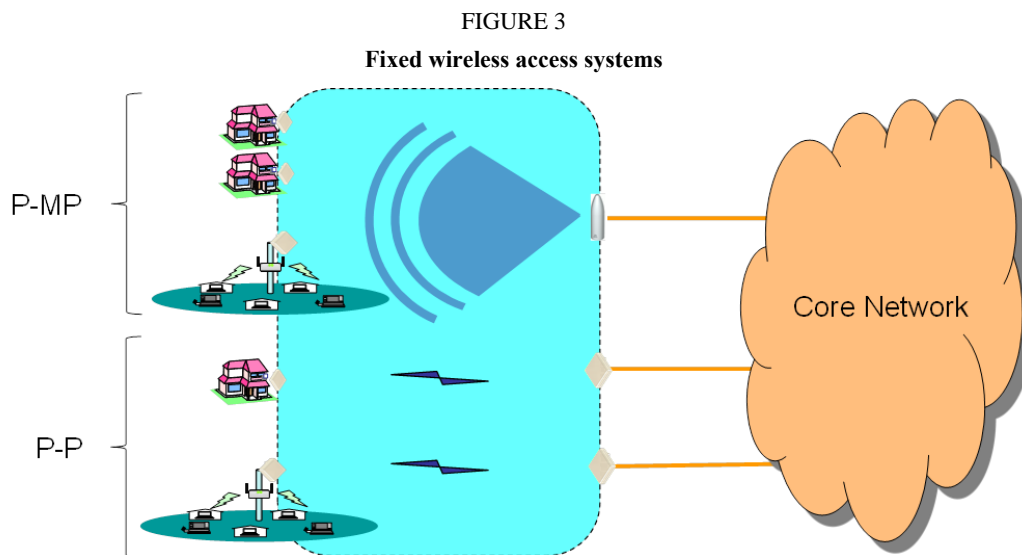

## 2.4 Temporary FS

### 2.4.1 Disaster recovery and physical diversity links

One of the advantages of wireless systems is short installation time. Another is that the systems can be pre-deployed with independent (or backed-up) power source, as physical-diversity configuration that supplements or substitute fibre networks. These features make them suitable for recovery when existing fibre networks are damaged in disasters, such as earthquakes and tsunamis. Following the earthquake that occurred in Japan in 2011, many cable links used for transport/trunking and mobile backhaul were damaged. Transportable FS equipment using the 11 GHz-band was used to recover damaged networks (see Table 2 in Annex 1 to Recommendation ITU-R F.1105). Moreover, during this earthquake, fifteen percent of damaged mobile base stations were recovered by using transportable FS equipment for temporary backhaul provision. During and after Hurricane Sandy in the United States of America in 2012, the physical-diversity made by independently-powerable fixed wireless backhaul systems continued to perform in areas where fibre backhaul had failed. Future

challenges for disaster recovery links are (1) to increase the capacity/data rate, (2) to offer compatibility with the latest network interfaces, and (3) to decrease power consumption, since these disaster recovery links should be operated by portable batteries or portable generators until power supplies are recovered.

#### **2.4.2 Electronic news gathering**

Electronic news gathering (ENG) is another example of temporary use applications of FWS. System characteristics and user requirements for ENG and other broadcasting auxiliary services (BAS) in the FS are specified in Recommendation ITU-R F.1777. Report ITU-R BT.2069 and Report ITU-R BT.2344 provides information on the current status of ENG. ENG enables the relay of a live TV broadcast from various places where a wired network has not been installed.

Existing wireless ENG links transmit digital high-definition (HD) videos using video signal compression, because the bandwidth of the wireless link is below 100 Mbit/s while the digital HD video standard for high definition serial digital interface (HD-SDI) signal has a data rate of 1.485 Gbit/s. The latency due to the video signal compression using MPEG-2 video makes live TV program production difficult in many cases. Recent progress in video compression technologies, such as H.264/MPEG-4 AVC and H.265/HEVC, allow the reduction of the latency below 30 milliseconds. Nonetheless, there is still a strong requirement for wireless links that can transmit HD-SDI signals without compression, because video compression deteriorates the video quality. The 60, 70 and 80 GHz bands can support a large transmission capacity of uncompressed HD-SDI signals. TV program material has already been transmitted using these bands.

Ultra-high definition television (UHDTV) is certainly one of the major applications of next-generation digital broadcasting. Accordingly, Recommendation ITU-R BT.2020 – Parameter values for ultra-high definition television systems for production and international programme exchange – was published in 2012. Since then, UHDTV broadcasting services have been started in many countries via satellites, cables, and the Internet, furthermore 8K UHDTV satellite broadcasting will be started in 2018 in Japan. With ever more programmes being produced for UHDTV, wireless links for BAS that can transmit UHDTV have become an urgent requirement. Uncompressed transmission of 4K/8K UHDTV videos have already been experimentally demonstrated using 60-GHz-band and 120-GHz-band wireless links (see Report ITU-R BT.2344 for 120-GHz-band system). Furthermore, experiments on a 42-GHz-band BAS system have been conducted to transmit 8K UHDTV video compressed with H.265/HEVC as shown in Annex 5.

#### **2.5 Low latency microwave applications**

High-Speed Trading, also known as High Frequency Trading (HFT) in the financial sector, is a recent and growing addition to the list of applications supported by FWS. The concept behind this application is simple; reduce the time taken for financial trading instructions to be transmitted between major financial centres. The key is low latency point-to-point FWS. Typically, low latency private microwave links are used to “replace” traditional fibre based networks linking financial centres. The business driver for microwave-instead-of-fibre in low latency is the time it takes to transmit trading instructions. With microwave, end-to-end latency is reduced by a few milliseconds as compared to fibre. Nevertheless, those few milliseconds can translate into a trading edge over rival investors, which translate into increased revenue. It is this increased revenue that is driving investment in these applications.

There are challenges to building these networks, especially as the single most important factor to the users is “speed”. This user emphasis on speed may have an impact on operators’ deployment decisions. For example, link capacity may be sacrificed in order to achieve the lowest possible latency through the network by use of lower order modulation (16/32-QAM) schemes in preference to the current industry trend of moving to ever higher modulation schemes such as 256/512-QAM. Network

availability can be sacrificed to some degree because the pre-low latency fibre network is still operational, meaning that four 9's availability is often acceptable in this application whereas in many other networks five 9's availability is part of the design criteria.

The rationale behind this is to "stretch" the length link in order to keep the number of regenerators to an absolute minimum as each regenerator will add to the overall latency of the network.

In addition, the latency in IP/Ethernet based networks of new generation of mobile systems plays a significant role (certainly for VoIP, but also for other system considerations) and it is commonly understood that it should be kept under control and as low as possible. Therefore, the lower latency of radio links versus fibre optic links remains an advantage for Fixed links applications. This advantage is also expected to be an important consideration in future mobile networks based on IMT-2020. Report ITU-R M.2410 provides minimum requirements for user plane latency of 4 ms for enhanced mobile broadband (eMBB) and 1 ms for ultra-reliable and low-latency communications (URLLC), as well as minimum requirements for control plane latency for both eMBB and URLLC of 20 ms although encouraging to achieve 10 ms. Since a traditional microwave link has an average delay of 100 microseconds, it provides lower end-to-end latency than fibre, which usually has longer length (not straight between two locations) and has to account for the lower propagation speed of light through glass compared to air. Finally, it should also be noted that newer gigabit microwave solutions are expected to have an improvement factor of up to 10 times in delay.

### 3 FWS band usage

#### 3.1 General consideration

Figure 4 shows the trend in the use of higher frequency bands by the FS, which can be seen from the approval years of ITU-R F-Series Recommendations on RF frequency arrangements. In 2012, ITU-R F-Series Recommendations for radio-frequency channel and block arrangements were approved for the 71-76 GHz and 81-86 GHz bands (Recommendation ITU-R F.2006). Moreover, Report ITU-R F.2107-2, that covers bands up to 134 GHz was approved in 2011.

This trend indicates that studies in ITU-R on frequencies over 100 GHz will likely be required before 2020.

FIGURE 4  
Exploitation of higher frequency bands in FS

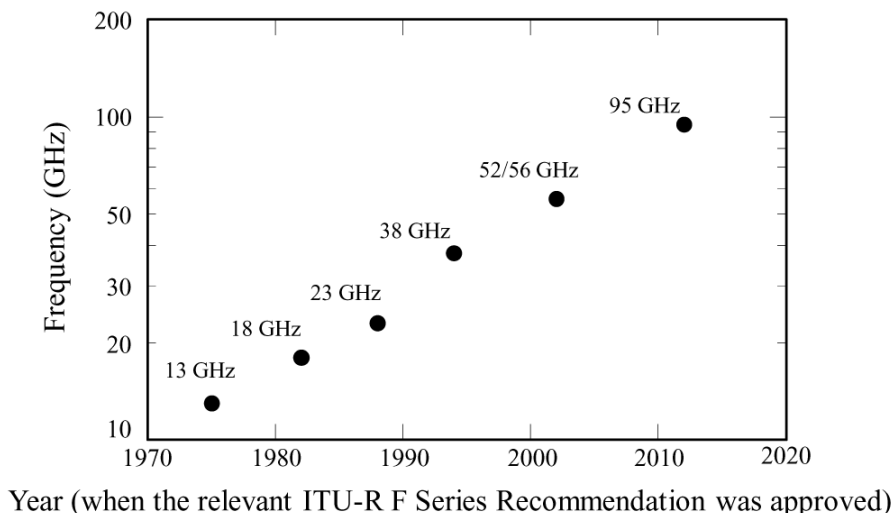
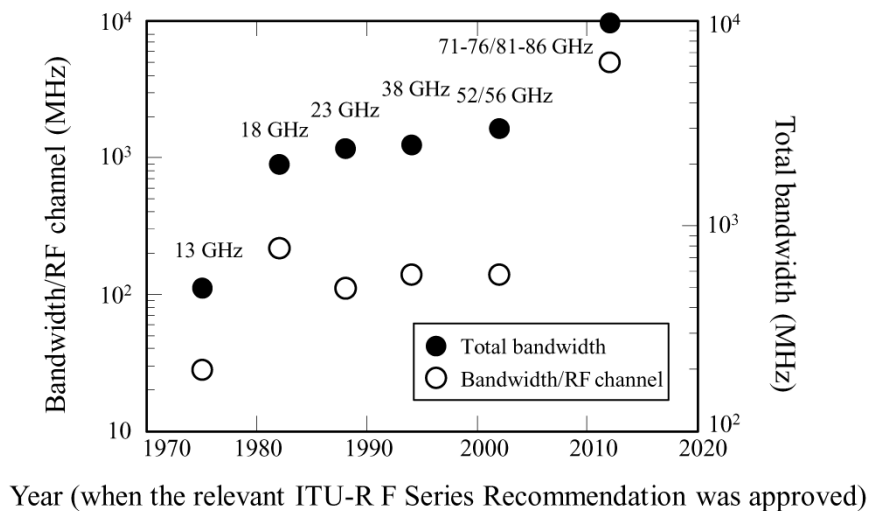

Figure 5 shows the trend of the bandwidth of FS, which is reflected from the approval years of ITU-R F-Series Recommendations on RF frequency arrangements. Before 2002, the maximum RF bandwidth per channel and total bandwidth in the 18 GHz band were 220 MHz and 2 000 MHz, respectively. The 38 GHz band, which is sometimes licensed in wide-area blocks, was capable in 2002 of supporting 200 links per square km<sup>6</sup>. In 2012, the ITU-R F-Series Recommendation for radio-frequency channel and block arrangements in the 71-76 and 81-86 GHz bands (Recommendation ITU-R F.2006) provides a bandwidth per channel up to 5 GHz, enabling 10 Gbit/s data transmission. The maximum transmission distance of FWS in the 71-76 and 81-86 GHz bands is only a few kilometres (depending on channel bandwidth, rain intensity and modulation format). Therefore, the frequency reuse efficiency is expected to be very high in the case of FWS in the 71-76 and 81-86 GHz bands.

FIGURE 5  
Bandwidth of the FS



### 3.2 Spectrum use in each band

As an overview of the trend of FS bands in detail, Table 1 summarizes characteristics and applications of the fixed service described in the ITU-R F-series Recommendations on RF channel arrangements above 1 GHz. All the ITU-R F-series Recommendations for the bands above 40 GHz were approved after the year 2000.

It is noted that the bandwidths of several FS band segments above 40 GHz exceed 3 GHz, and that, according to the relevant Recommendations on RF channel arrangements, the bandwidths per channel are also increasing in the higher frequency bands (e.g. in the 70 and 80 GHz band it becomes over 1 GHz). This trend is a result of the congestions of certain frequency resources below 40 GHz and the increase in the demands for broadband FS.

<sup>6</sup> Recommendation ITU-R F.1498.

TABLE 1

## Example of characteristics and applications of frequency bands for the Fixed Service

Band (GHz)	Typical applications	Recommendation ITU-R	Bandwidth per channel (MHz)	Typical data rates
1.35-1.53	Transport, utilities	F.1242	0.25, 0.5, 1, 2, 3.5	64-4 000 Kbit/s
3.6-4.2	Transport	F.635	30, 40, 80	155 Mbit/s
5.925-6.425	Transport, mobile backhaul	F.383	5, 10, 20, 28, 29.65, 40, 80	155 Mbit/s
6.425-7.125	Transport, mobile backhaul	F.384	5, 10, 20, 30, 40	34-311 Mbit/s
7.11-7.9	Transport, mobile backhaul	F.385	3.5, 5, 7, 14, 28	8-155 Mbit/s
10.0-10.68	ENG	F.747	1.25, 2.5, 3.5, 5, 7, 14, 28	
10.15-10.3/ 10.5-10.65	ENG	F.1568	28, 30	
10.7-11.7	Transport, trunk networks, mobile backhaul, disaster recovery, ENG	F.387	5, 7, 10, 14, 20, 28, 56, 112, 40, 60, 80	140 Mbit/s, 155.52 Mbit/s
11.7-12.5/ 12.2-12.7	Transport, trunk networks, ENG	F.746 Annex 2 § 2, § 3	12.5, 19.18, 20, 25	40 Mbit/s
12.75-13.25	Transport, trunk networks, ENG	F.497	3.5, 7, 14, 28	34-140 Mbit/s
14.25-14.5		F.746 Annex 3 Annex 4	3.5, 7, 14, 28	34 Mbit/s
14.4-15.35	Transport, mobile backhaul, ENG	F.636	2.5, 3.5, 5, 7, 10, 14, 20, 28, 30, 40, 50, 56, 112	
17.7-19.7	Mobile backhaul, FWA	F.595	1.75, 2.5, 3.5, 5, 7, 7.5, 10, 13.75, 20, 27.5, 30, 40, 50, 55, 60, 110, 220	<10 Mbit/s, 34, 140, 280 Mbit/s
21.2-23.6	Transport, mobile backhaul, FWA	F.637	2.5, 3.5, 7, 10, 14, 15, 28, 40, 50, 56, 112, 224	1.5-8 Mbit/s 2-155 Mbit/s
24.25-25.25/ 25.25-27.5/ 27.5-29.5	Transport, macro and small cell mobile backhaul, FWA	F.748	3.5, 7, 14, 28, 56, 112	
31.0-31.3	Transport, mobile backhaul	F.746 Annexes 5, 6	3.5, 7, 14, 25, 28, 50	
31.8-33.4	Transport, mobile backhaul, FWA	F.1520	3.5, 7, 14, 28, 56, 112, 168	
36.0-40.5	Macro and small cell mobile backhaul, FWA	F.749	2.5, 3.5, 7, 14, 28, 50, 56, 60, 112, 224	
40.5-43.5	Transport, trunk networks, macro and small cell mobile backhaul, ENG, FWA	F.2005	7, 14, 28, 56, 112, 224 or variable sized blocks (Each block size < 1 500 MHz)	

TABLE 1 (*end*)

Band (GHz)	Typical applications	Recommendation ITU-R	Bandwidth per channel (MHz)	Typical data rates
51.4-52.6	Transport, macro and small cell mobile backhaul,	F.1496	3.5, 7, 14, 28, 56	
55.78-57/ 57-66	Transport, macro and small cell mobile backhaul,	F.1497	3.5, 7, 14, 28, 50, 56, 100, up to 2.5 GHz	Up to 1 Gbit/s and greater
71-76 81-86	Transport, macro and small cell mobile backhaul	F.2006	125, 250, 750, 1 000, 1 250, 1 500, 1 750, 2 000, 2 250, 2 500, 2 750, 3 000, 3 250, 3 500, 3 750, 4 000, 4 250, 4 500, 5 000	

### 3.2.1 Below 3 GHz

FWS below 3 GHz can reach links lengths exceeding 50 km and are used in variety of applications including utilities, public safety and also for connecting remote areas and far offshore islands.

The available bands for these applications are very few in number and often regulated at national level; the total available bandwidth and channel separations are small; therefore, only small and medium capacity links are possible, but compatible with the intended use.

In the case of links with rapidly increasing capacity requirements (e.g. broadband network transport, mobile backhaul), there is a general trend to migrate these links to higher frequencies in order to meet the evolving increased transport capacity requirements). The recommended radio-frequency channel arrangements in these bands for FS are defined in Recommendations ITU-R F.701, ITU-R F.1098, ITU-R F.1242, ITU-R F.1243 and ITU-R F.1567.

### 3.2.2 3 GHz to 10 GHz

FWS from 3 GHz to 10 GHz can achieve over 50 km hop distance, and they are used for a variety of applications, typically for transport (long-haul), connections (including backhauling) in rural areas or to provide links to far offshore islands and other applications where higher bands are not suitable due to propagation characteristics and associated equipment deployment profile/characteristics.

Total bandwidth is sufficient for channel separations up to 28/40 MHz (or, when practical twice 28/40 MHz size); high capacity links are then possible. For such purposes, bands from 3 GHz to 10 GHz will continue to occupy an important position in the FS applications including for transport network and mobile backhaul.

The radio-frequency channel and block arrangements of these bands for FS are defined in Recommendations ITU-R F.382, ITU-R F.383, ITU-R F.384, ITU-R F.385, ITU-R F.386, ITU-R F.635, ITU-R F.1098 and ITU-R F.1099.

### 3.2.3 10 GHz to 57 GHz

FWS using bands from 10 GHz to 30 GHz permit maximum link lengths ranging from about 20 km, at the lower edge of this frequency range, to about 10 km at the upper edge. Those from 30 GHz to 57 GHz can cover about a few km. As shown in Figs 6 and 7, the transport networks and mobile backhaul mainly use the frequency bands from 10 GHz to 38 GHz, and the number of FWS links has been continuously increasing in recent years. It was also reported (in 2002) that 38 GHz-band FWS can support over 200 links per square kilometre, number possibly exceeded today.

The radio-frequency channel and block arrangements of these bands for FS are defined in Recommendations ITU-R F.387, ITU-R F.497, ITU-R F.595, ITU-R F.636, ITU-R F.637, ITU-R F.747, ITU-R F.748, ITU-R F.749, ITU-R F.1496, ITU-R F.1498, ITU-R F.1520, ITU-R F.1568 and ITU-R F.2005.

#### **3.2.4 57 GHz to 66 GHz**

It should be noted that this Recommendation was developed first in 2000 for bands up to 59 GHz only. Frequency bands 59 to 64 GHz is gathering interest in particular due to a high atmospheric absorption which provides opportunity for small cell backhauling and for other private links (e.g. for Fixed LAN Extensions between different buildings described in Annex 1).

Also the 64-66 GHz range, where the atmospheric absorption drops down significantly, gathers interest for similar applications where longer hops are foreseen. In 2011, around 700 links were in use in this band (mainly in the 57-59 GHz range) in a few administrations. The majority of the links were used for fixed and mobile infrastructure.

The air absorption around 60 GHz (i.e. from 58 to 64 GHz) is over 10 dB/km. This condition restricts the hop length; on the other hand, the spectrum reuse efficiency is high and isolation from inter-satellite links as also very high. The spectrum reuse efficiency makes the band suitable for small cell mobile backhaul.

The radio-frequency channel and block arrangements of these bands for FS are defined in Recommendation ITU-R F.1497.

#### **3.2.5 71 GHz to 76 GHz and 81 GHz to 86 GHz**

As of 2013, these bands have been recently exploited for practical use. Most applications are foreseen for FWS links used for fixed and mobile infrastructure.

In these bands, wide bandwidth can be used and the attenuation due to gas absorption is relatively small compared with the 60 GHz band and, in practice negligible. Therefore, this band is suitable for high-capacity transmission.

The radio-frequency channel and block arrangement of these bands for FS are defined in Recommendation ITU-R F.2006.

#### **3.2.6 92 GHz to 95 GHz**

As of 2013, the use of this band is just beginning. Most applications are almost the same as that with 71-76 and /81-86 GHz bands. However, the total bandwidth of this band is 2 GHz and 0.9 GHz (92.0-94.0/94.1-95 GHz), and then the data rate of FWS in this band is smaller than that possibly provided in 71-76 and /81-86 GHz bands. The band is lightly licensed in Canada and the United States of America.

### **3.3 Spectrum use in specific regions**

Globally, about 4 million microwave backhaul hops are in operation today. Figure 6 illustrates the extent of microwave backhaul usage by region and band – the size of each circle is relative to the number of microwave hops in operation (Source: [3]).

FIGURE 6  
Global use of microwave backhaul

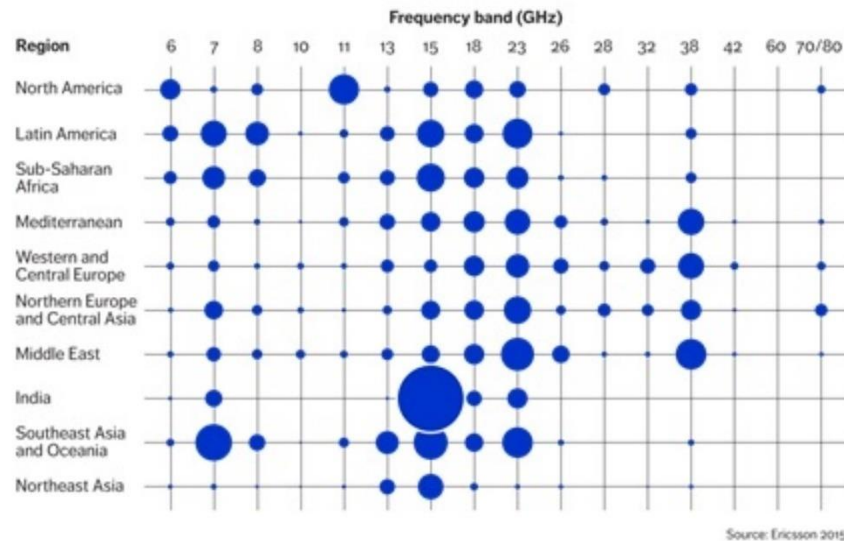

More specific details are provided in the following sub-sections.

### 3.3.1 Europe

This section depicts the spectrum use of FWS in Europe. The data given in this section is based on a survey conducted by the Electronic Communications Committee (ECC) of Conf rence Europ enne des administrations des Postes et des T l communications (CEPT) between September 2010 and January 2012 on spectrum requirements and technology trends for FS in Europe post-2011. The analysis of this data is included in ECC Report 173 (published in summer 2012).

The trends in bands from 10 GHz to 38 GHz in Europe are shown by comparing the data in 1997, 2001 and 2010. Figure 7 presents the number of links in these years, and shows the high levels of recent growth, for bands in the 10-38 GHz range.

FIGURE 7  
Trends of links for each band in Europe

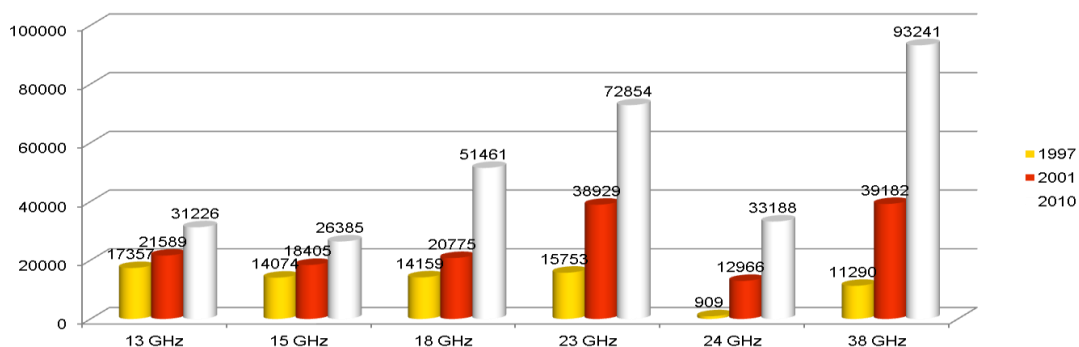

The growth of FWS in these bands in Europe was attributed to increased demand for mobile backhaul. This trend will continue for coming years with demands for higher capacity and more links due to the expected large scale deployment of wider bandwidth mobile technologies (e.g. UMTS/HSPA/HSPA+/LTE/IMT-Advanced). In particular, increasing usage of the 38 GHz band is expected in coming years in many CEPT administrations.



Figure 8 presents the use of frequency bands of the fixed point-to-point services in Poland (based on the data available on the website of the UKE – Polish Regulatory Body). The increase in the 23 GHz-band and 38 GHz-band is remarkable. Moreover, 176 point-to-point services at 70/80 GHz-bands are used in 2013.

FIGURE 8  
Trends of links for each band in Poland

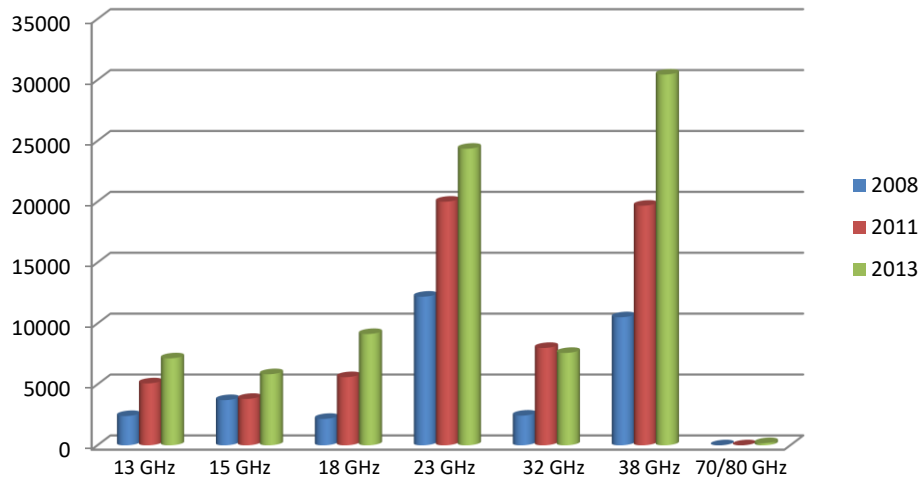

### 3.3.2 Asia

#### 3.3.2.1 Japan

Figure 9 shows the number of links used for the transport/ trunking, and the mobile backhaul in Japan. The number of wireless links is greatest in the 11 GHz band, and the use of 15 GHz-band and 18 GHz band were increasing rapidly as of 2009. These show the trend to the frequency bands used for FWS shifting to higher frequency bands. These bands are mainly used for mobile backhaul. FWS still plays an important role in mobile backhaul to support the increase of traffic in mobile systems although in Japan fibre optics are the main technology adopted for mobile backhaul.

In 2011, the change of the Ordinance Regulating Radio Equipment made it possible to use 70/80 GHz band wireless links in Japan, and these links are expected to spread hereafter.

FIGURE 9  
Trends of links for each band in Japan

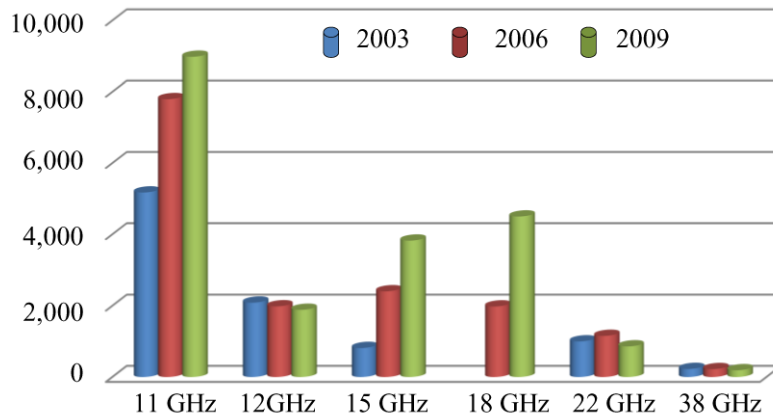

### 3.3.2.2 Viet Nam

This section depicts the spectrum use of FWS in Viet Nam. The data given in this section is based on a spectrum usage survey conducted by the Authority of Radio Frequency Management (ARFM) – Ministry of Information and Communication (MIC) from the year 2006 to 2011. The analysis of this data is included in MIC Report 43 – 11 – KHKT-RD in 2012.

FIGURE 10  
Trends of FWS for years in Viet Nam

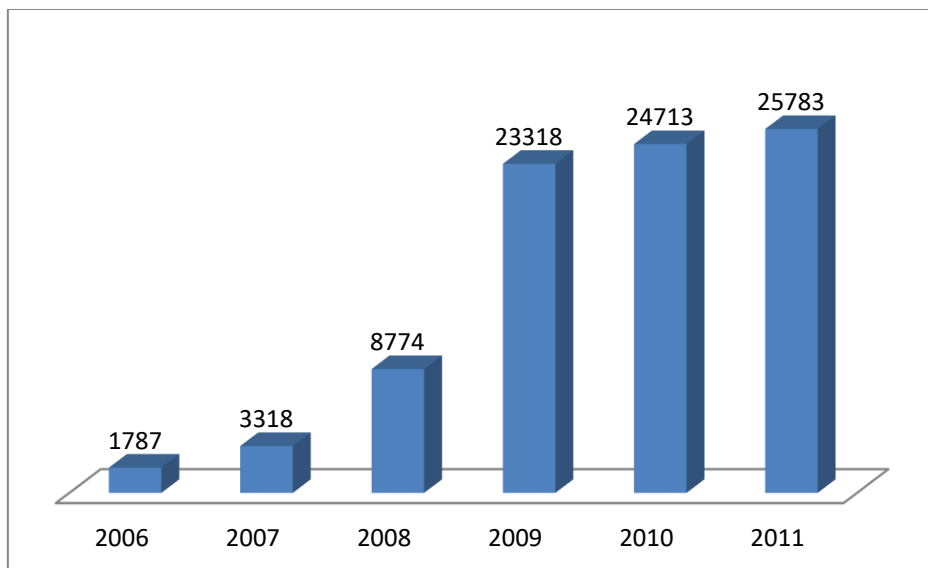

The trends of FWS are shown in Fig. 10 by the number of microwave links nationwide in these years. The growth of FWS started from the year 2006. The sharp growth in 2008-2009 periods is driven by the expansion of 7 GSM networks coverage to make preparations for migrations to 3G which occurred in the end of 2009.

FIGURE 11  
Trends of links for each frequency band in Viet Nam

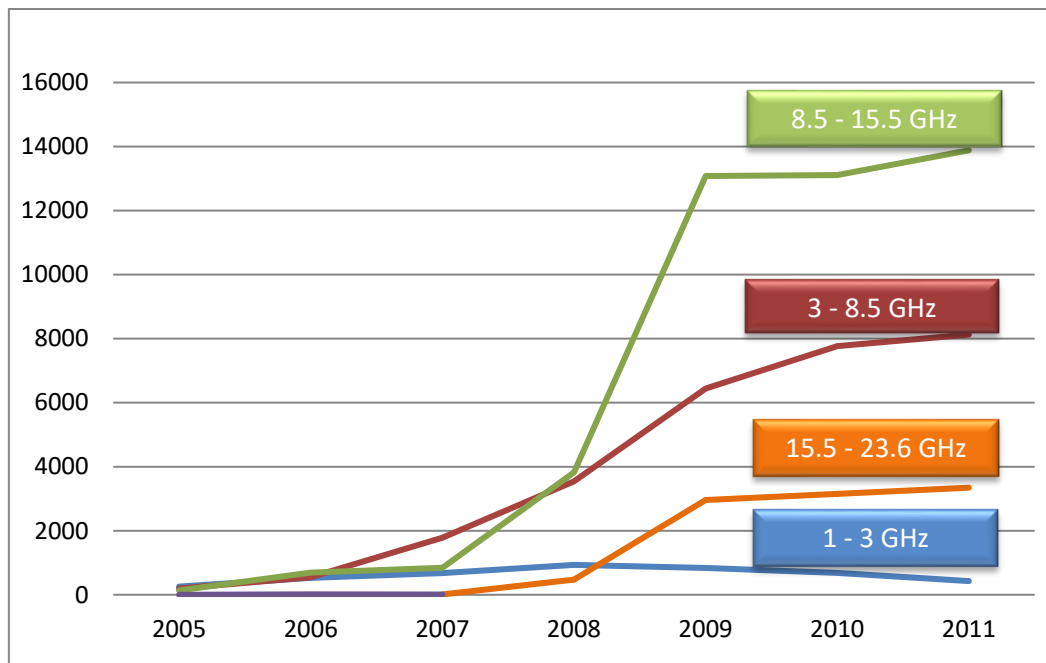

Figure 11 shows the Trends of links for each frequency band. The remarkable trends in the 7/8 GHz and 15 GHz bands were attributed to increased demand for mobile backhaul, mostly high capacity transmission. This trend is expected to continue for coming years with demands for higher capacity and more links due to the expected new deployment of next generation of mobile broadband systems (IMT-Advanced) particular focus in the bands above 20 GHz.

There are some trial projects of multiple gigabits wireless system being conducted in the millimetric wave band.

FIGURE 12  
Distribution of links for path length in Viet Nam

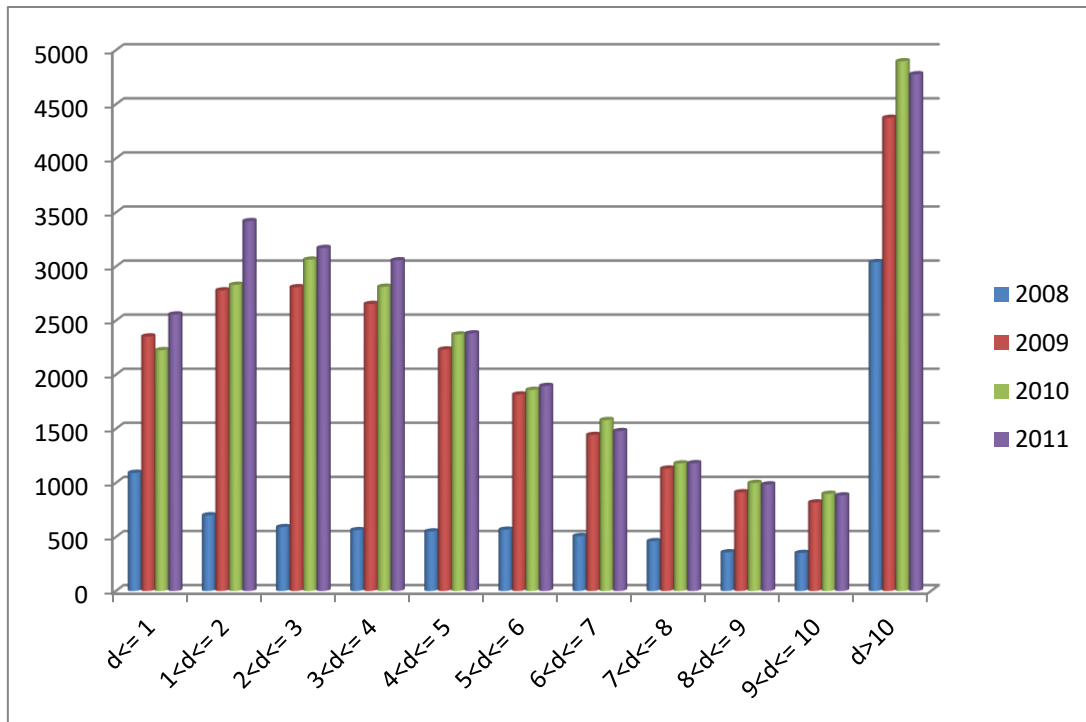
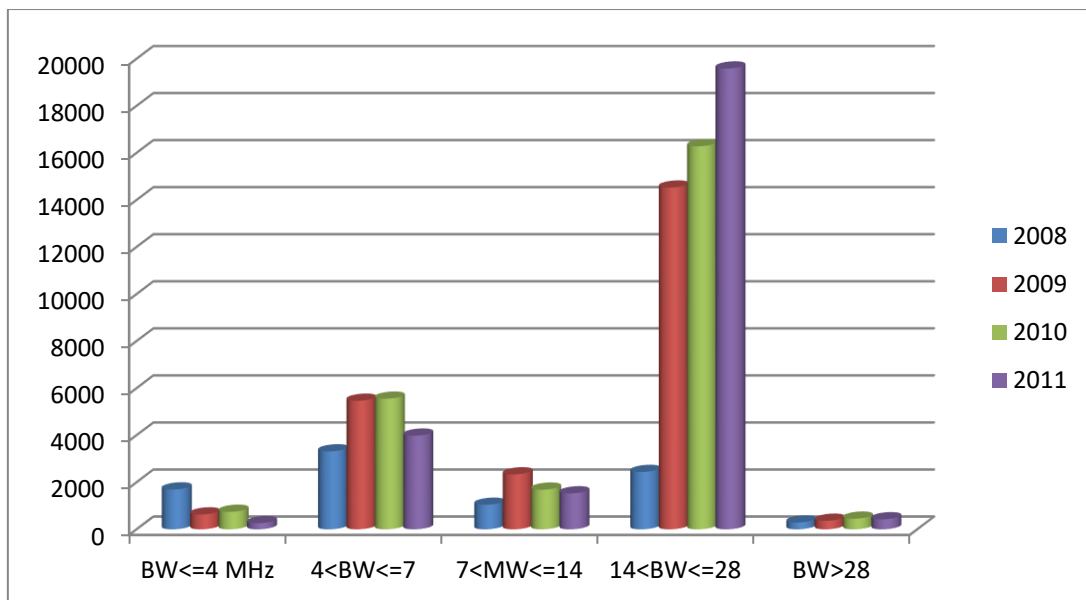

FIGURE 13  
Distribution of links for channel width in Viet Nam



Figures 12 and 13 show the distributions of links for path length and channel width, respectively. Transition from 2G mobile network mostly deployed in spectrum under 1.9 GHz to IMT system in the band 2.1 GHz lead to the reduction of hop-length, shown by 50% of link is less than 5 km length. Path-length of backbone transmission is normally more than 10 km, rightmost on Fig. 12. This transition also required large channel width to provide high data rate backhauling. The domination of 28 MHz BW link in Fig. 13 proves this trend.

### 3.3.3 North America

#### 3.3.3.1 United States of America

This section depicts the spectrum use of FWS in the United States of America for the FCC CFR 47 Part 101 point-to-point microwave 6 GHz to 23 GHz frequency bands. The information in this section is based on data extracted from the FCC license database for the years 2003, 2008 and 2012 and represents the total active links for the identified year. The trends in the 6.1 GHz and 11 GHz continue to show strong usage in the traditional long haul, high capacity applications. This growth is driven by the 3G to 4G migrations by the mobility operators, and by state & local government sectors in support of public safety Land Mobile Radio (LMR) backhaul, utility smart grid, and transportation communication network upgrades as they transition from TDM to IP services. Continued heavy reliance on these critical frequency bands in the coming years is envisioned as FirstNet, the US Government initiative that promises to provide emergency responders with the first nationwide, high-speed network dedicated to public safety LTE applications, is implemented. Heavy reliance on the 6.1 GHz and 11 GHz band will continue to support the mobility market's backhaul requirements in rural locations as well. Dramatic growth is also occurring in the higher frequency bands. The 18 GHz and 23 GHz bands trends are driven primarily by mobility operators as they backhaul their LTE traffic and some early implementations of small cell traffic, both mainly in the metropolitan markets. While 18 GHz and 23 GHz links are shorter in comparison to 6 GHz and 11 GHz links, these bands offer mobility operator increased capacity and the ability to license smaller antennas.

FIGURE 14  
Trends of links for each band in the United States

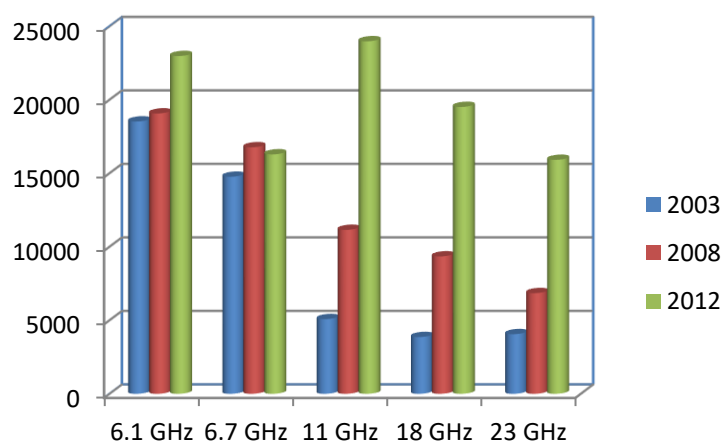

Data courtesy of Comsearch

#### 3.3.3.2 Canada

Figures 15 and 16 show frequency assignments in Canada from 1998 to 2010 in two bands predominantly used for fixed services<sup>7</sup>. It shows respectively an increase of 600% and 800% which is believed to be due to increased requirements for higher capacity short-haul networks for broadband cellular systems. The overall conclusion of this inventory snapshot is that:

- backhaul spectrum usage has been growing rapidly in recent years, likely driven by increasing capacity requirements in support of cellular mobile networks, and

<sup>7</sup> This data have been gathered from a Radio Spectrum Inventory snapshot taken in 2010 (see <http://www.ic.gc.ca/eic/site/smt-gst.nsf/eng/sf10023.html>).

- it is not expected that this increase will slow down in the future.

FIGURE 15  
Trends of frequency assignments for 10.7-11.7 GHz in Canada

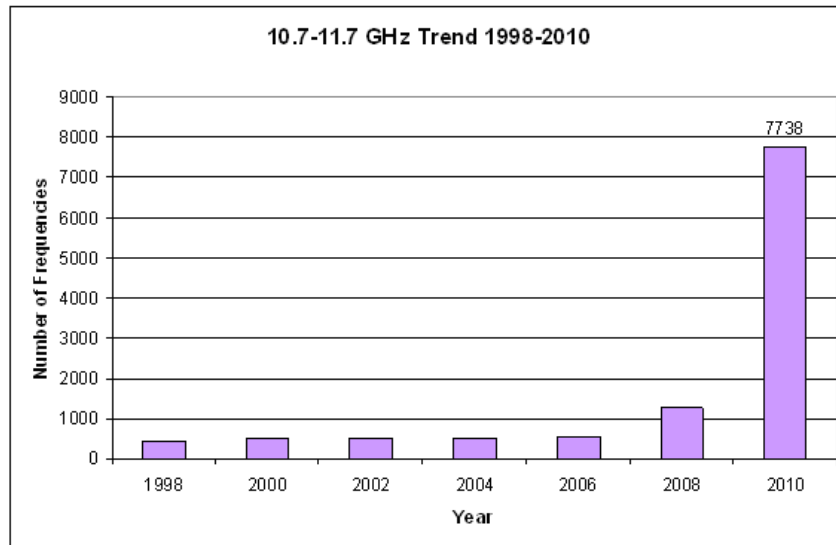
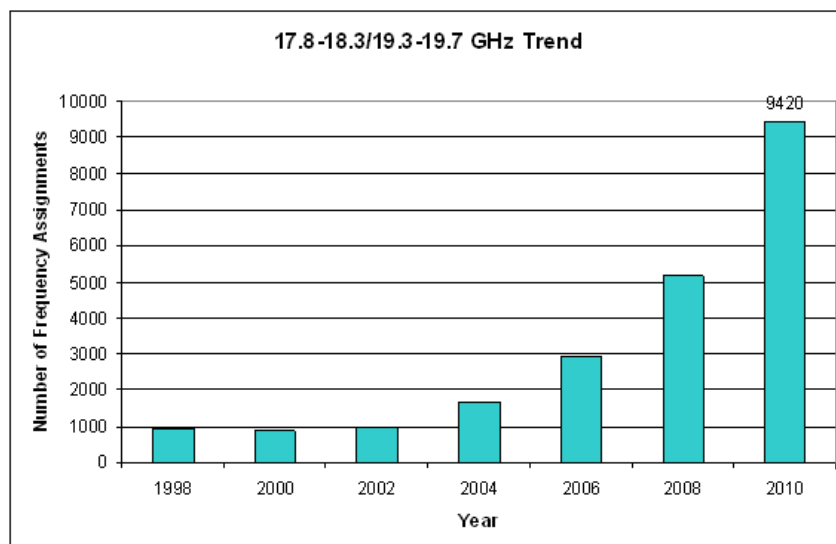

FIGURE 16  
Trends of frequency assignments for 17.8-18.3/19.3-19.7 GHz in Canada



This trend has been confirmed by an “outlook” document<sup>8</sup> indicating that, even though extensive fibre networks have been built in populated areas and along major highway corridors, there has been a considerable increase in requests for wireless backhaul licences over the past few years. Of all backhaul spectrum, the 11-23 GHz frequency range is the most heavily used in Canada and some areas of Canada are experiencing congestion. To resolve the congestion, two avenues are being considered:

- adding spectrum to address the demand, and

<sup>8</sup> Refer to <http://www.ic.gc.ca/eic/site/smt-gst.nsf/eng/sf09444.html>.

- taking advantage of technological advances to increase flexibility and to promote increased spectrum efficiency.

### 3.4 Sharing and compatibility studies with other services

FS often shares frequency bands with other services and sharing conditions with these services were generally developed for bands up to 50 GHz. With a view to future use of new frequency bands by the FS (including frequency bands above 100 GHz), if requested by WRC, it is becoming more and more important to consider sharing and compatibility issues between FS and other services.

Many studies of frequency sharing between the FS and other services are addressed in ITU-R Recommendations. In particular sharing with the FSS is addressed in a number of SF-series Recommendations. Some studies on sharing between FS systems and other radio services are covered mostly in F-series Recommendations. Various aspects of these studies are summarized in Tables 2 and 3. These study results will provide good references and/or examples for possible studies on the higher frequency bands. Some key considerations include whether the current or intended FS deployments will occur in high density configurations. Another consideration is that the bands above 20 GHz evidence much higher elevation angles than traditional below 20 GHz FS deployments, thus making bore-sight interference from FSS systems more likely.

For carrying out sharing and compatibility studies between systems in the FS and systems in other services, deployment scenarios may be required in some cases. Recommendation ITU-R F.2086 contains information on deployment scenarios and related statistics for some point-to-point FWSs in the fixed service operating in the frequency range 1.4-86 GHz. This Recommendation is intended to be used in conjunction with Recommendation ITU-R F.758.

TABLE 2

#### Summary of general sharing and compatibility studies between FS and other services

Topics	Frequency band <sup>(1)</sup>	ITU-R Recommendation
System parameters and general considerations	Above 30 MHz	F.758
Interference criteria with respect to non-GSO space stations	10.7-12.75 GHz	F.1494
	17.7-19.3 GHz	F.1495
	37-40/40.5-42.5 GHz	F.1606
Interference criteria with respect to GSO space stations	37-40/40.5-42.5 GHz	F.1669
Maximum allowable error performance and availability degradations due to interference from other sources	Above 30 MHz	F.1094
Performance degradation due to interference from other services to real FWS used in the international and national portions of a 27 500 km HRP <sup>(2)</sup> .	All bands	F.1565

<sup>(1)</sup> Use of frequency bands may be different in different Regions.

<sup>(2)</sup> Hypothetical reference path.

TABLE 3

## Summary of sharing and compatibility studies between FS and other services

Other service sharing the same band with FS	Frequency band <sup>(1)</sup>	ITU-R Recommendations or Report
BS	174-230, 470-862 MHz	Rec. ITU-R F.1670
BSS	1 452-1 492 MHz	Rec. ITU-R F.1338
EESS, RAS	71-76/81-86/92-94 GHz	Rep. ITU-R F.2239
EESS, SOS, SRS	2 025-2 110/ 2 200-2 290 MHz	Rec. ITU-R F.1247
EESS, SRS	5 250-5 350 MHz	Rec. ITU-R F.1613
FSS	3 400-3 700 MHz	Rec. ITU-R SF.1486
	10.7-12.75 GHz	Rec. ITU-R SF.1482
	17.7-19.3 GHz	Rec. ITU-R SF.1483
	27.5-29.5 GHz	Rec. ITU-R SF.1719
ISS	25.25-27.5 GHz	Rec. ITU-R F.1249, Rec. ITU-R F.1509
MS	470-694/698 MHz	Rep. ITU-R F.2331
	800 MHz/1.9 GHz	Rec. ITU-R F.1402
	1-3 GHz	Rec. ITU-R F.1334
	1 350-1 527 MHz	Rep. ITU-R F.2333
	3 400-4 200 MHz	Rep. ITU-R F.2328
	4-6 GHz	Rec. ITU-R F.1706
	4 400-4 900 MHz	Rep. ITU-R F.2327
5 925-6 425 MHz	Rep. ITU-R F.2326	
MSS	1-3 GHz	Rec. ITU-R M.1141 Rec. ITU-R M.1142 Rec. ITU-R M.1143
RLS	3.4-3.7 GHz	Rec. ITU-R F.1489
	4-6 GHz	Rec. ITU-R F.1097
	71-76/81-86 GHz	Rep. ITU-R F.2394

<sup>(1)</sup> Use of frequency bands may be different in different Regions.

### 3.5 FWS regulatory regimes

#### 3.5.1 Licensed FWS

In most cases, FWS are licensed. There are 3 licensing regimes commonly used:

- 1) Link by link licensing gives licensee the right to access specific pair of frequencies for proposed microwave link. The frequency assignment, interference analysis and spectrum fee calculation are performed in link by link basis. It is also reported that numbers of Administrations are following this regime in FWS bands under 30 GHz.



- 2) Another link-by-link licensing approach is a spectrum assignment, which is a grant of a predefined block of channels in a channel arrangement for nationwide or more limited geographic area, to a major network operator, disregarding how many links will be installed. Other major operators are granted similar contiguous block of channels. They are responsible for planning and interference analysis of their own network as well as for coordination among them.

Periodically they report the link data to the administration that records them on national data base and may calculate the related fees.

The administration retains the ownership of those channels and, in principle, may still locally license other links to other smaller users.

- 3) Some administration grants wide-area/block assignment license in FWS bands including e.g. 24 GHz, 26 GHz, 28 GHz, 31 GHz and 37-40 GHz; such licensing method, implies that, within that geographic area or block of frequency, the exclusive licensee is responsible of its own planning (of whichever number of links without any imposed channel arrangement), while respecting the “border” (geographic or of the frequency block) conditions studied and imposed by the administration granting the license. One user has usually paid for a particular piece of the spectrum, and has use of that slice of the spectrum and is therefore expected to be not under threat of harmful interference from other entities in the same geographic area, except (a) where the borders of wide-area licenses cross the same geographic area or (b) if the operator of a system on an adjacent channel configures that system in a manner to cause harmful interference. Either potential interference case can be addressed through coordination rules.

In principle, licensing of new FWS has to comply with certain conditions so as not to cause harmful interference with existing FWS and other systems.

### 3.5.2 License-exempt FWS

License-exempt spectrums mean spectrum bands that have rules pre-defined for hardware and sometimes also deployment methods of radios. In this manner, interference is mitigated by the technical rules defined for the bands rather than restrictions on use of the band through a licensing procedure. Some of the most commonly used license-exempt bands are 2.4 GHz, 5 GHz, and 60 GHz. The 2.4-GHz and 5-GHz bands are used for RLANs. Building RLAN bridge is an application of FWS, and the use of high-gain antenna enables building RLAN bridges spanning distances of over 10 km. Spectrum in the high-50 GHz and low-60 GHz ranges has been assigned on a license-exempt basis in many administrations. The path loss at 60 GHz is much larger than the losses at other frequencies because of oxygen absorption. This makes the band attractive for short-range communications as it further attenuates interference, such as co-channel interference in wireless cell-based systems, which combined with low transmit powers in the 60 GHz band can increase the density of frequency-reuse cells. In the United States of America, Canada, and Korea, 60 GHz radios operate over 7 GHz of spectrum extending from 57 GHz to 64 GHz. In the United States, higher emission limits (up to 85 dBm peak e.i.r.p.) for 60 GHz devices that operate outdoors with very high gain antennas are allowed to encourage broader deployment of point-to-point broadband systems<sup>9</sup>. In Japan, the spectrum from 57 GHz to 66 GHz is generally assigned for license-exempt usage. China assigns 57 GHz to 62 GHz for license-exempt use. In Europe, the band 57 GHz to 64 GHz has been assigned for license-exempt usage.

---

<sup>9</sup> United States Federal Communications Commission, Revision of Part 15 of Commission’s Rules Regarding Operation in the 57-64 GHz band, ET Docket No. 07-113.

Deployment can be rapidly carried out by using license exempt FWS. Due to its status, license-exempt FWS have possibility of suffering harmful interference from other links. Advancements in adaptive antenna array technology [4] and beamforming techniques as applied to millimetric wave bands, however, could help in reducing harmful interference, especially in multipath environments [5].

### 3.5.3 Light-licensed FWS

In 2003, the U.S. adopted a flexible and innovative regulatory framework for the 71-76 GHz, 81-86 GHz and 92-95 GHz bands that would not require traditional frequency coordination among domestic non-federal government users. Rights with regard to specific links can be established based upon the date and time of link registration. A license for the 70 GHz, 80 GHz and 90 GHz bands can be obtained on a non-exclusive nationwide basis. This is combined with site-based link registration process. In some administrations in Europe and other regions, various forms of light licensing are also in force.

The bands of 71-76 GHz, 81-86 GHz and 92-95 GHz have larger free space transmission loss than the bands below 60 GHz, and FWS in these bands use highly directional antennas. Therefore, FWS using these bands are lesser probability to interfere with one another. For this reason, licensing (intended as frequency planning under total administration control) may not be necessary in these bands. However, it may not be desirable for major carriers to use unlicensed spectrum due to the lack of protection from interference from other carrier's systems. Light licensing is a national regulation to accommodate the minimal regulatory constraints and costs with some assurance of a protected spectrum.

The 71-76 GHz and 81-86 GHz bands are lightly licensed in the Czech Republic, Sweden, and the United States. In addition, Canada has announced its intention to allow light licensing in future. The United Kingdom has recently reviewed its licensing arrangements for this band to facilitate both light licensed and centrally managed FWS applications. The 92-95 GHz band is also lightly licensed in United States. Some other countries, have also foreseen centrally managed band on link-by-link basis licensing regime.

## 4 FWS technology and trends

### 4.1 FWS technologies

Recommendation ITU-R F.1101 covers some of the technologies used in the present FWS. The technologies widely used in the present FWS are as follows.

- Multi-level QAM.
- XPIC (Cross Polarization Interference Canceller).
- Equalizer.
- FEC (Forward Error Correction).
- ATPC (Automatic Transmit Power Control).
- ACM (Adaptive Code and Modulation).

Multi-level QAM and XPIC are used to maximize the frequency usage efficiency of FWS.

QPSK and multi-level QAM from 16-QAM to 256-QAM are generally adopted for a modulation scheme for FWS. Progress in semiconductor devices now enables us to employ 1 024-QAM and work up to 4 096-QAM. However, the higher-order modulation requires an even higher carrier to-noise ratio (CNR). Moreover, the use of 1 024 QAM increases the data rate only by 1.25 compared with 256-QAM. 1 024-QAM modulation schemes and above are not widely used, and they are foreseen to be limited when adaptive modulation is concerned.

Polarization multiplexing is another way to increase the capacity without bandwidth expansion. However, interference between the two polarizations causes some degradation of BER performance, especially when using high multilevel modulation schemes. This interference can be cancelled by reproducing the “interference condition at the channel” in the demodulator. XPIC generates a replica of interference from the orthogonal polarization, allowing its output to be “subtracted” (or effectively cancelled) from the received signal.

Equalizer and FEC are employed for improving the data transmission characteristics.

FWSs often employ adaptive equalization as a counter measure against distortions due to frequency selective fading, and in order to compensate for imperfections in hardware. The equalizers contribute to not only performance improvement but also equipment cost reduction, because introduction of the equalizer enables the use of less expensive RF devices. Generally, an adaptive time domain equalizer (ATDE) is adopted. There are two types for the configuration: One is a Linear Equalizer (LE) using finite impulse response (FIR) filters and the other is a Decision Feedback Equalizer (DFE) with two FIR filters.

FEC can reduce BER performance degradation from various causes. Among the error correcting codes available for FWS, the most popular is Reed-Solomon code. Sometimes, a coded modulation scheme such as TCM (Trellis Coded Modulation) is applied. Today, more powerful codes, such as low-density parity-check (LDPC) code, which is based on iterative decoding, are being adopted.

When ATPC is implemented on a FWS link<sup>10</sup>, a transmitter on that link may operate at a reduced power under favourable propagation and operating conditions. Clearly, a transmitter using ATPC will produce less interfering power than a transmitter operating at the maximum power. Different administrations may impose different limitations on the implementation of ATPC, and these limitations may depend on whether multipath fading or rain fading is the dominant performance impairment in a particular frequency band.

In a typical implementation of ATPC, the Received Signal Level (RSL) is monitored at the receiver and sent to the transmitter. When the RSL falls by a prescribed amount below its expected level, the transmitter increases its power to partially offset further reductions in RSL. All of these considerations may need to be taken into account in the frequency coordination of the link. As shown in § 3.3.1, the use of higher frequency bands, when rain attenuation is important, is increasing. It will be important to quantify how the implementation of ATPC will facilitate sharing with other services in these frequency bands.

ACM is used for changing the modulation schemes and coding rates according to the channel condition, such as rain. FWS are increasingly used for data transmission, and the capacity levels therefore do not need to correspond exactly to the legacy circuit switching interface. This allows the capacity to be varied by changing the modulation schemes and coding rates according to the channel condition. In this way, it is possible to ensure that the most important signals can survive, even under severe conditions by allowing a down shift of modulation. Although this comes with a reduction in capacity, the alternative would have been a complete loss of communications on the link. This approach is interesting when coupled with IP/Ethernet traffic dynamic capacity control, where different QoS priorities are given to differently important traffic and where non-essential traffic can be momentarily lost without impacting services supported by the FWS.

Used with or without ACM, dynamic traffic capacity management is useful when transporting traffic based on IP data transmission. As mentioned above, this allows prioritizing the transport of some traffic over others, providing additional reliability for some services more sensitive to packet loss. In bands above 60 GHz, where very large bandwidths are possible, in the order of 1 GHz or more, the

---

<sup>10</sup> The advantages of using ATPC are limited when not used by a majority of links in a geographical area.

technology might not accommodate very high modulation formats over most links for lack of sufficient fade margin for guaranteeing commonly expected availability. Present equipment operates on no more than 2 or 4 states modulation formats and 16/32-QAM will already be a challenge for the future. For this reason also a different adaptive methodology, referred as “band-adaptive systems”, might also be employed. During adverse propagation, the system extends the receiver BER threshold, for a portion of the payload, reducing the bandwidth rather than dropping the modulation level. In this way longer links may also be covered with satisfactory capacity/quality trade off.

#### 4.1.1 Link design methodology

##### 4.1.1.1 Conventional links enhancement

The potential higher susceptibility to interference is successfully overcome by applying careful planning of link budgets and, when the coordination procedure foresees the use of Automatic Transmit Power Control (ATPC) to limit transmitted power in congested networks, the planner should consider the joint interaction of ATPC and Adaptive Modulation. The joint use of adaptive modulation and ATPC requires careful consideration in order to balance the advantages separately offered by those technologies.

The problematic related to the use of adaptive modulation, independently from the ATPC use, shows that, as a function of the reference modulation format (i.e. the format corresponding to the high priority traffic capacity requiring the conventional degree, e.g. 99.99%, of link availability) and the AM maximum available modulation format, a minimum nominal “clear sky” RSL (corresponding to a minimum fade margin) should be provided for fully exploiting the adaptive modulation potentiality. Consequently, very short hops, requiring might need special attention (see § 5 where short hops need is further detailed).

When ATPC is added in the coordination process of adaptive modulation links, Fig. 15 shows that the available ATPC range is link-by-link variable and, in addition, the available ATPC range is limited for guaranteeing error free operation; this may limit the range of ATPC available for planning purpose. The minimum RSL defined for planning the network with ATPC enabled (nominal clear sky RSL with ATPC enabled) should be higher than the minimum required including suitable systems safeguards for avoiding malfunctions or preventing full use of the adaptive modulation operation.

It should also be noted that, in adaptive modulation systems, a portion of available ATPC range is always enabled; this, here called “step ATPC”, is used for managing the required output power drop for linearity purpose between the “reference modulation” (i.e. 16-QAM in the example) and the highest modulation (i.e. 256-QAM in the example). The “total ATPC” available for planning purpose is then achieved by adding the conventional presettable “linear ATPC” range (see Fig. 17) according to the equation:

$$A_{ATPC\ total} = A_{ATPC\ step} + A_{ATPC\ linear} \quad (1)$$

These effects have to be taken into account for a case-by-case trade-off between the link parameters. In hops where the required Fade Margin (FM) is low, it might be possible that there is no margin either for permitting the excursion of the whole set of modulation formats and/or for permitting any ATPC range.

FIGURE 17  
 Fade Margin and ATPC range impact to adaptive modulation  
 (ECC Report 173)

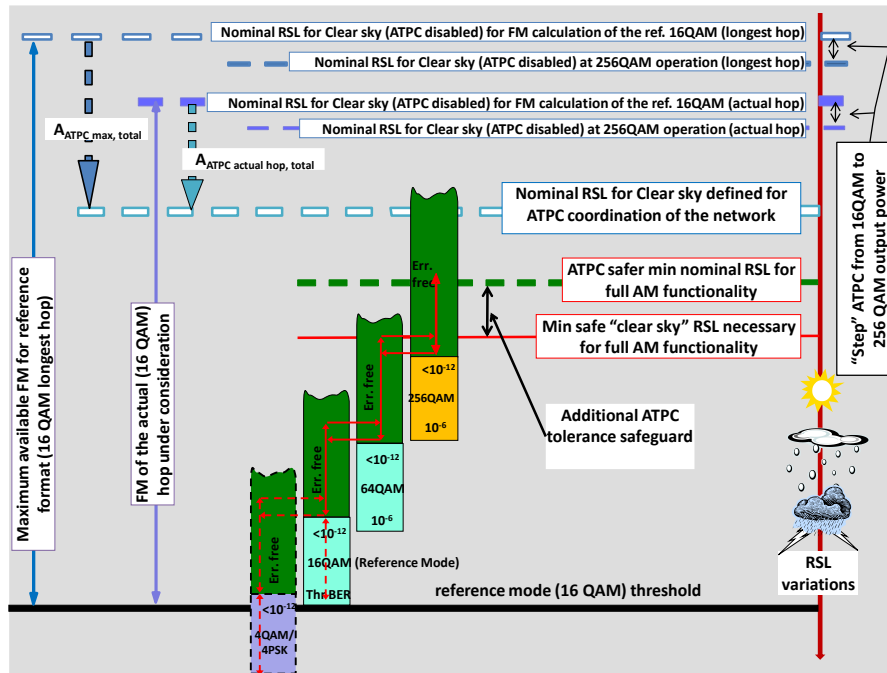

#### 4.1.1.2 New links topology

In the various options under study for suitably respond to the small cells backhauling problem, it has to be considered that the design of PP links deeply entering the streets canyons in urban areas, even if still in LOS conditions, could not disregard the issue of reflection on building and other urban clutters. This may also require further study in the propagation prediction methods, in particular when higher frequency bands are concerned [1].

#### ITU-T G.8032v2 networking

Microwave networks have historically relied on daisy chain and tree backhaul topologies, as shown in the top portion of the following figure, even though the benefits of rings over these linear topologies were well known:

- Since traffic can be sent in two directions around a ring, the load capacity of the ring is effectively doubled when no failures exist.
- Rings offer a reduction in protection CAPEX spend since each ring site has two paths around a ring, this eliminates the need for fully protected aggregation sites that have only one path to the broader network.

The main reason for the reluctance to deploy ring architectures in the past was due to bandwidth inefficiencies associated with SONET/SDH protocols. Specifically protection bandwidth had to be reserved, bandwidth that could not be optimally used when no failures in the network were present. This wasn't a limitation in higher capacity fibre networks, but it was a severe limitation when trying to leverage scarce microwave spectrum. Hence, rings never emerged as a widely deployed microwave network topology.

A new Ethernet based networking protocol was required to take the place of SONET/SDH, to support the gold standard of 50 ms protection, and with the ability to optimally carry IP services. The ITU-T G.8032v2 standard has evolved to be this protocol and is a natural fit for packet microwave networks as they too are based on an underlying Ethernet technology.

## Microwave network topology evolution

FIGURE 18

Microwave network topology evolution

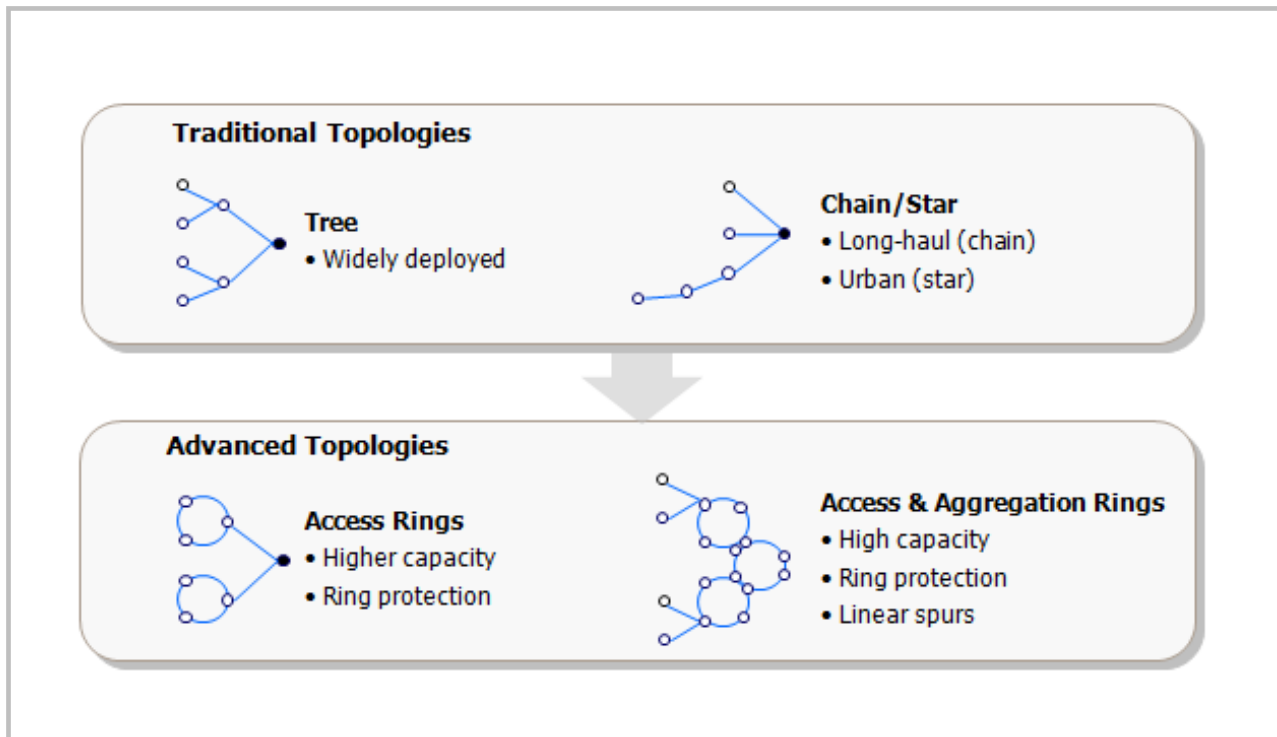

Since Recommendation ITU-T G.8032v2 is based on Ethernet, it can be used over any Ethernet media be it over copper, fibre, or packet microwave. Ethernet channel bonding techniques such as the aforementioned multichannel can also be used to scale microwave capacity.

FIGURE 19  
ITU-T G.8032v2 networking on a ring break

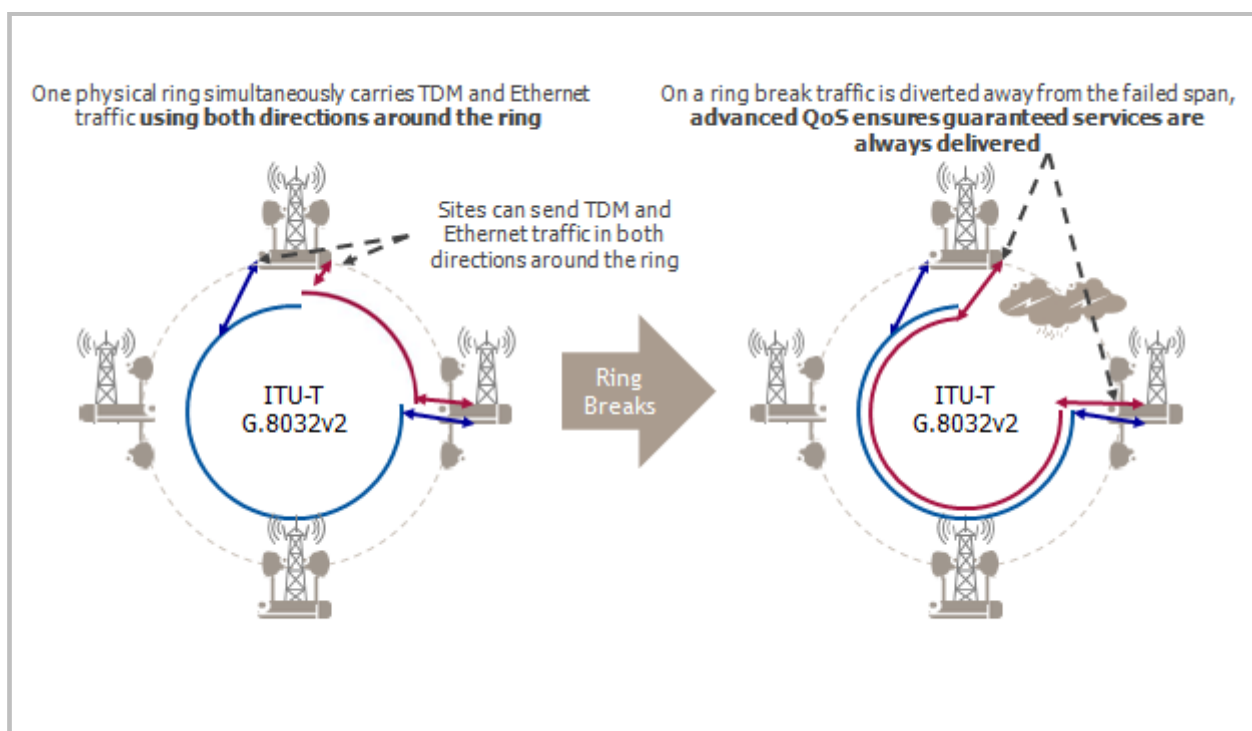

#### 4.1.2 Wider bandwidth channels and channel aggregation

A possible technology to increase capacity is to use wider bandwidth channels. According to Table 1, the bandwidth per channel for 71-76/81-86 GHz band is  $N \times 250$  MHz and, the maximum bandwidth channel is 5 000 MHz. Such wide bandwidth can achieve multiple gigabit transmission.

In addition, channel aggregation technologies can be applied to FWS. In these technologies, two or more channels are combined and treated as single channel, including potentially the aggregation of non-contiguous channels.

This is an attractive solution for providing additional data throughput, which is an important feature to fulfil backhaul of traffic from base station to core network in IMT and IMT-Advanced deployments without having to deploy a new link. The increasing demand for high bandwidth channels will be an important consideration in development of new or revised FWS channel plans including relevant ITU-R Recommendations.

Multiband solutions, which enable enhanced data rates by combining resources in multiple frequency bands, already constitute an essential part of modern radio access systems. Their significance will, however, increase in the coming years, as they enable efficient use of diverse spectrum assets, and as such will support the evolution of LTE and 5G technologies [3].

## 4.2 Antennas

### 4.2.1 Passive antennas

Most FWS in bands above 3 GHz use parabolic antennas, including front feed antenna, offset feed antennas, Cassegrain antennas, and Gregorian antenna. However, some FS in bands below 3 GHz in particular 1.4 GHz band uses mix of flat panel, Yagi and parabolic antennas due to low profile and other installation/infrastructure considerations for these applications.

The gain of a parabolic dish antenna  $G$  is expressed as follows:

$$G \text{ [dBi]} = 10 \log\left(\frac{4\pi A}{\lambda^2} e_A\right) = 10 \log\left(\frac{\pi^2 D^2}{\lambda^2} e_A\right) \quad (2)$$

where  $A$  is the area of the antenna aperture,  $D$  is the diameter of the parabolic reflector,  $\lambda$  is the wavelength of the radio wave, and  $e_A$  is a dimensionless parameter between 0 and 1 called the aperture efficiency. The aperture efficiency of typical parabolic antennas is 0.55 to 0.70. Figure 20 shows the antenna gain calculated by using equation (2). The diameter of the parabolic antenna for FWS can be selected by considering the link distance, carrier frequency, output power, receiver sensitivity and availability of the link.

However, according to Recommendation ITU-R F.699 the 3 dB beamwidth ( $\theta$ ) angle of the main radiation lobe is roughly given by:

$$\theta \cong 70 * \frac{\lambda}{D} \cong 70 * \frac{1}{10^{\frac{G-7.7}{20}}} \quad (3)$$

It is commonly intended that antennas with gains higher than about 50 dBi (i.e. with a 3 dB angle smaller than about 0.5 degrees) are not practically useable unless complex and expensive automatic pointing device is also implemented.

FIGURE 20  
Relationship between parabolic antenna gain and antenna diameter ( $e_A = 0.55$ )

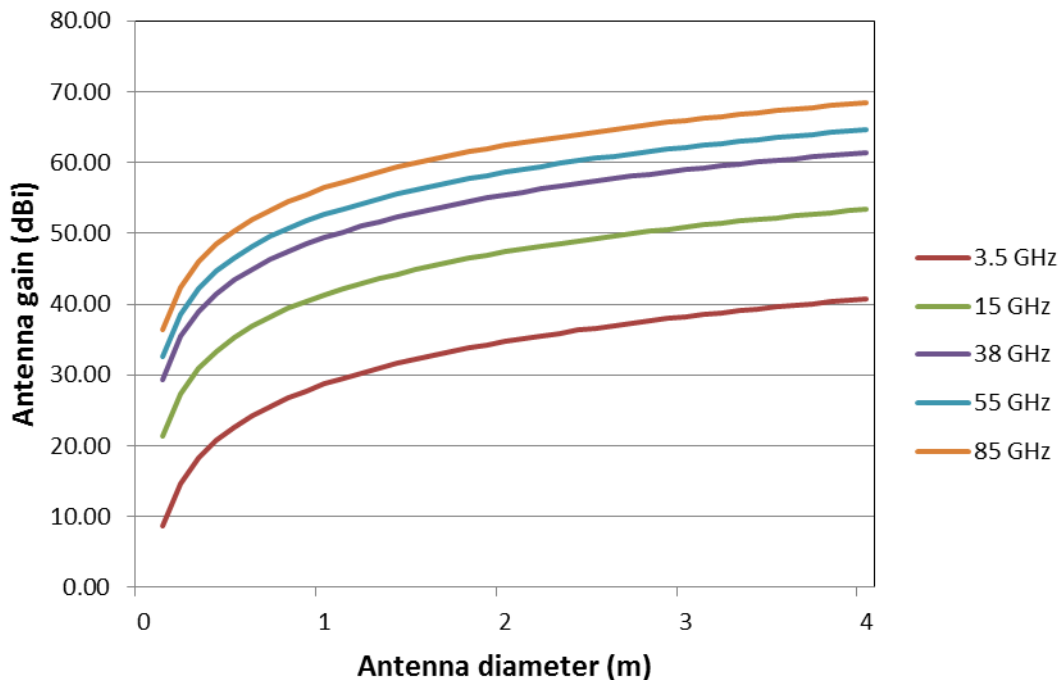

The use of antennas other than parabolic antennas, such as slot or patch arrays, has been investigated in order to reduce antenna cost, improve the antenna characteristics for specific applications and limit visual pollution, which can allow deployment in areas not possible using parabolic-type antennas.

One of the most promising technologies is slot array antenna; some examples in the 60 GHz range are already on the market.



This kind of integral antenna may offer additional benefits; for example, a prototype broadband point-to-point FWA system in the 38 GHz band with a maximum throughput of 1 Gbit/s is being developed in Japan. A low-profile waveguide slot array antenna is incorporated in this system, since it has advantages of low loss and high antenna efficiency even in the millimetric-wave band. Moreover, this FWA system differs from the conventional time division duplex (TDD) and frequency division duplex (FDD) systems and adopts a novel configuration in which two separate antennas [6] operating at the same frequency with the same polarization are arranged in the H-plane for the individual transmission and reception as shown in Fig. 21. From the viewpoint of the system designs, sufficiently high spatial isolation between those two antennas can dispense with the TDD-switch, whose insertion loss in the millimetric-wave band is extremely high.

An antenna aperture size of 136 mm  $\times$  136 mm is provided to achieve the desired antenna gain of more than 33.5 dBi with antenna efficiency of more than 70% over the frequency range of 38.0-39.5 GHz. The voltage standing wave ratio (VSWR) at the antenna input is less than 1.5 over this band. The antenna thickness is 5 mm. A shielding metal wall with 12-mm width and 10 mm height between the antennas is used to enhance the spatial isolation to more than 75 dB. Data with 600 Mbit/s can be transmitted for the maximum distance of 4.1 km using this system.

This antenna technology can be applied for higher frequency bands, such as over 120 GHz and 350 GHz. In the case of a 120 GHz-band waveguide planner slot array antenna, a 16 $\times$ 16-element array antenna shows 38 dBi gain with 70% antenna efficiency over 13 GHz bandwidth, and error-free transmission up to 10 Gbit/s is achieved at the centre frequency of 125 GHz using a wireless link system with the proposed antenna. A 32 $\times$ 32-element array antenna shows over 38 dBi antenna gain with over 60% antenna efficiency and 15 GHz bandwidth (119.0-134.0 GHz) and a 64 $\times$ 64-element array shows over 43 dBi antenna gain with over 50% antenna efficiency and 14.5 GHz bandwidth (118.5-133.0 GHz), respectively. In the case of a 16 $\times$ 16-element 350-GHz-band waveguide slot array antenna, the gain of 32 dBi with 74% antenna efficiency has been achieved [7] [8].

FIGURE 21

Low-profile waveguide slot array antennas with a shielding wall

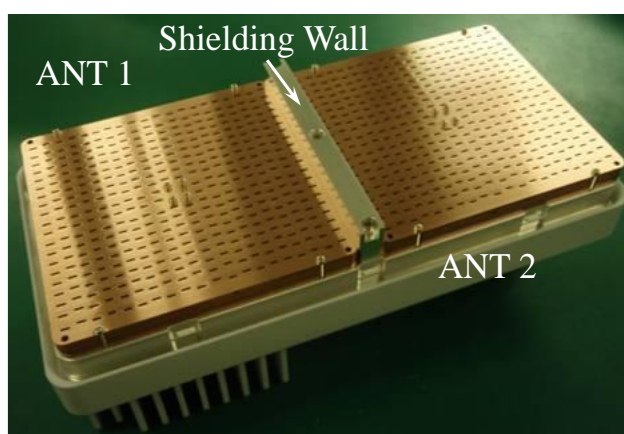

Another alternative antenna type is a flat panel antenna. This has the advantages of being visually less obtrusive, which has an advantage if the FWS is to be deployed in an area where planning restrictions may otherwise preclude use of traditional parabolic dishes. This is especially suitable for the millimetric wave bands where some applications, e.g. small cell backhaul, call for street level installation either on building sides/corners or street furniture.

#### 4.2.2 Active antennas

Near future evolution in the antenna technology may be related to the deployment of new mobile access networks, LTE and 4G, which will use smaller size cell footprint, especially in urban areas, the backhauling will require denser and shorter link networks. For active antenna systems used in base stations of IMT systems, Report ITU-R M.2334 addresses several aspects of these systems. In addition equipment may be installed on light poles at street level and shall not have a large visual impact. This will drive the use of smaller antenna which would likely be integral to the equipment itself.

This could highly help in link activation and for compensate slight modification in pointing due to poles vibrations and bending due to various unpredictable reasons (road works, car accidents); it could possibly help in reducing effect of multipath reflections from buildings nearby.

The consequent loss of directivity might be compensated using steering antenna, which can keep pointing in adaptive way even in an urban and changing environment where pole can be bent causing pointing misalignment (see Fig. 22a).

Furthermore, active antennas may also be driven by “beam-forming” algorithms for minimising interference, i.e. minimizing the gain in the direction of the higher interference eventually detected. This might become of major interest in dense urban environment for street level BS backhauling where reflection/diffraction phenomena become of importance.

FIGURE 22

a) Antenna with steering beam (both transmitting and receiving)

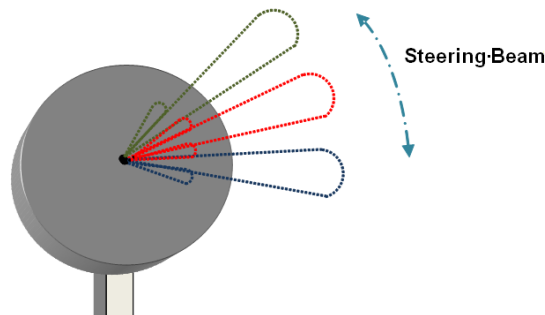

b) Antenna with beamforming capability (both transmitting and receiving)

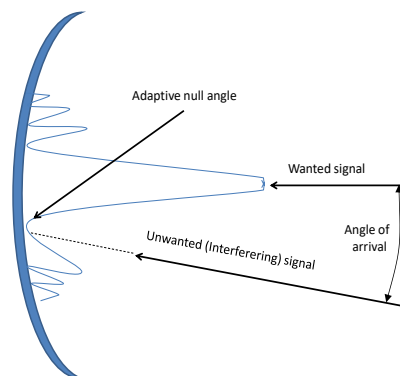

#### 4.2.2.1 Applicability of large/massive MIMO technologies to FWSs in mobile backhaul networks

Among applications utilizing FWSs described in § 2 of this Report, demands for mobile backhaul networks would be dominant in order to respond explosive traffic generated by mobile broadband terminals such as smartphones.

In addition, the explosive traffic generated by mobile terminals will require base stations with a smaller cell size, meaning that the number of cells and their density will increase compared with those in macro cells. These trends will result in a larger number of backhaul links required and their hop distances becoming shorter.

Taking these situations into account, technologies for FWSs to easily deploy a large number of mobile backhaul links are required. It is also noted that reduction of cost and size of the equipment for mobile backhaul links is important because a significant number of backhaul links would be deployed.

Regarding usage to have the benefit of FWSs to deploy a large number of mobile backhaul links, a point-to-multipoint (P-MP) FWS may be one of useful candidates. In P-MP FWSs, one central station antenna can communicate to a number of mobile base stations. So, a number of point-to-point (P-P) FWS station antennas at core network side could be replaced with a single central station of P-MP FWS antenna. This feature of P-MP FWSs, compared with P-P FWSs, may reduce the cost and/or size of stations at core network side. However, P-MP FWSs require higher gain antennas and/or higher transmission power at mobile base stations to achieve the same hop distance than P-P FWSs due to the use of omnidirectional/low gain-antennas of P-MP central stations. This fact results in increase of total cost of mobile backhaul networks.

A large/massive multiple input multiple output (MIMO) would be an attractive technology to solve the issues in P-MP FWSs and could reduce the cost and size of mobile backhaul networks compared with P-P FWSs. Figure 23 is a concept of mobile backhaul networks using FWSs with large/massive MIMO technologies.

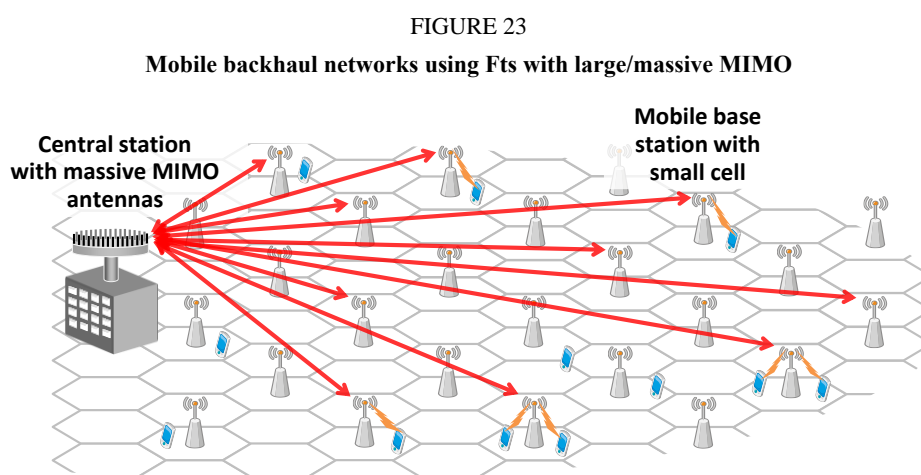

As described in Report ITU-R M.2334, MIMO is a general term that includes various spatial processing techniques: beam forming, diversity and spatial multiplexing. Beam forming can minimise interference and dynamically adjust the beam direction to cover mobile base stations in the system within the maximum gain of antennas. The use of diversity can provide additional diversity gains. Spatial multiplexing enables to transmit multiple signals in multiple streams to one (SU-MIMO) or more (MU-MIMO) terminals simultaneously. MU-MIMO means that multiple terminals can transmit or receive signals simultaneously. A large/massive MIMO is one kind of large scale antenna systems

which use a large number of antennas and achieves a high order of improvement by the spatial processing techniques.

With these features of large/massive MIMO, a mobile base station of P-MP FWSs could adopt the same gain antenna and the same transmission power as a mobile base station of P-P FWSs. As a result, the cost or size of the mobile base station of P-MP FWSs with large/massive MIMO would not increase.

MIMO including large/massive MIMO has been studied in mobile systems including IMT as shown in Reports ITU-R M.2334 – Passive and active antenna systems for base stations of IMT systems, and ITU-R M.2376 – Technical feasibility of IMT in bands above 6 GHz. However, there are some differences in radio environments between an FWS and a mobile system. For example:

- Generally, LOS is required in mobile backhaul networks using FWSs;
- Channel conditions in FWSs are more stable than those in mobile systems;
- With an FWS, location information for mobile base stations is known in advance and constant.

These features could reduce calculation complexity required for the larger number of antennas larger. As a result, a central station with higher total capacity and coverage of larger number of mobile base stations could be achieved.

One example of utilizing the features described above is shown with a new antenna arrangement such as parallelogram array realizing channel spatial correlation [9]. This antenna arrangement can enable greater side lobe control by a beamforming antenna to avoid other mobile base stations in a large/massive MIMO application. This allows the reduction of interference suffered at the backhaul nodes of other mobile base stations, and as a result allows higher backhaul capacity and coverage of a larger number of mobile base stations.

Moreover, the beam forming aspect of large/massive MIMO facilitates the installation of mobile base stations because beam forming can be used to dynamically adjust the direction of the antenna beams.

While these features of large/massive MIMO could bring a lot of benefit described above to FWSs in mobile backhaul networks, some information regarding dynamic beamforming and consequential dynamic changes to antenna radiations patterns should be further studied. Dynamic beamforming results in time-variant/location-variant side lobe patterns in a large/massive MIMO system, and this may add some new challenges in sharing with other systems. However, in FWSs, channel conditions are more stable and the location information for other systems (e.g. mobile base stations from other systems, or other FWS stations) is constant and known in advance. As a result, it is expected that time-variant antenna radiation patterns of large/massive MIMO in FWSs could be easier to calculate and coordinate in advance using the known locations of stations from other nearby systems, compared with the unknown locations of user terminals within mobile systems. Large/massive MIMO technologies are independent of frequency range. However, it is noted that with higher frequency bands such as above 60 GHz, the size of antennas could be reduced and a larger number of antennas could be implemented. This means that one central station could cover more mobile base stations. In addition, the higher frequency bands have wider bandwidth and can achieve more capacity. These facts are desirable to deploy mobile backhaul networks for mobile broadband systems which demand explosive traffics.

### 4.3 Further evolutionary scenario

Other technological evolutions are under assessment for possible applications in the FS marketplace related to the evaluation of the possible options for effective backhauling evolution of mobile systems (i.e. related to small cells deployment and to significant increase in traffic capacity):

- Non Line of Sight (NLoS) or Quasi Line of Sight (QLOS) backhauling applications in low frequency bands (typically below, but not limited to, 6 GHz<sup>11</sup>); which may solve the interconnection of mobile pico-cells at street levels. An important part of the challenge is the search for suitable frequency band(s) for such applications; it is well known that frequency resources below 6 GHz are very scarce and most of the “fixed allocations” have already been switched to, or looked for, MWA/BWA use, which imply, in common practice, that the bands are usually auctioned in blocks of relatively small size. This has already generated the idea of “in-band backhauling” (i.e. the use of the same auctioned block for both access and backhauling); however, this sometimes conflicts with the national licensing/auctioning rules (e.g. requiring “access only”) or, in any case, imply that the backhaul capacity would reduce the access capability and that, standing the limited block bandwidth, there will be strong limitation to the planning of P-P links (in term of capacity and availability of channels for interference reduction purpose). A second option could be the “off-band backhauling” (i.e. the use of a frequency band different from that of the access); possibly, the few bands still in use for conventional coordinated P-P deployment (e.g. 1.5 GHz, 2 GHz and 4 GHz), but not presently expected to support new systems deployment (see band-by-band analysis in Annex 1), might be taken into consideration. A third option of using license exempt bands (e.g. 2.4 GHz and 5 GHz), provided that e.i.r.p. limitation currently enforced would permit practical P-P application could be limited by the already extensive use for “urban” applications (RLAN) and highly impacting technical limitations (DFS for primary radars protection); nevertheless, it still deserves careful analysis. Last but not least, recent field tests [1] have shown encouraging results in NLoS behaviour of links in the frequency range about 20 to 30 GHz.
- Multiple-Input and Multiple-Output (MIMO) systems; this is a technology currently looked at for MWA systems; however, it can be effectively applied for PP links in higher bands, e.g. above 15 GHz, where the required spatial distance of the various antennas becomes practical (see Fig. 24). Figure 24 shows an optimal distance for a maximum capacity increases function of frequency and length. This technology could increase capacity (Spatial Multiplexing) and/or link availability (Space Coding).
- Significant deployment of high frequency bands, larger channel size and short hop length FWS are expected trend in coming years with large scale deployment of new broadband mobile technologies (e.g. IMT-Advanced system). Furthermore a combination of MIMO and Dual-Polarization frequency reuse system is becoming suitable in order to exploit dual-polarized antenna to simplify the deployment in field (see Annex 3). An example of systems using the Multi-Polarized MIMO technology in 18 GHz band is shown in Annex 3 [ETSI TR 102 311].

---

<sup>11</sup> Recommendation ITU-R P.1411-5 – Propagation data and prediction methods for the planning of short-range outdoor radiocommunication systems and radio local area networks in the frequency range 300 MHz to 100 GHz, contains NLoS propagation model in urban street canyons up to 16 GHz.

FIGURE 24

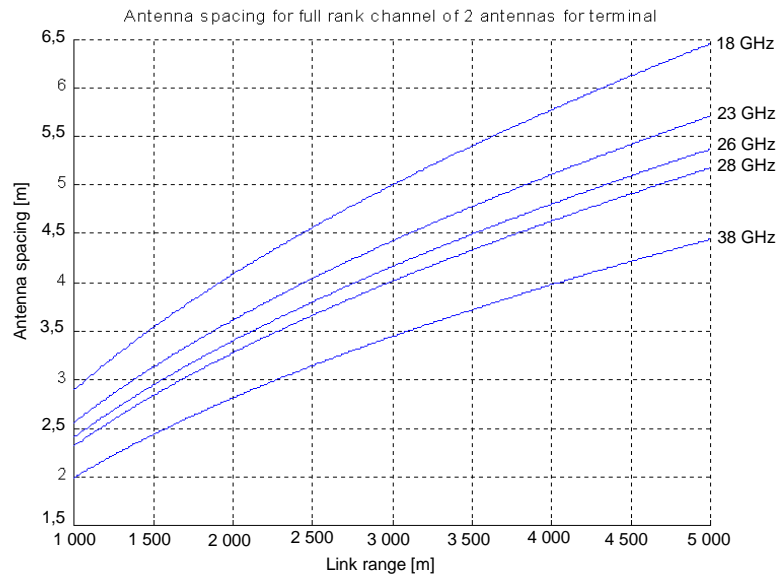
**Antenna spacing for maximal orthogonal case ( $d_{opt}$ )**

- The introduction of mobile communications services based on IMT (IMT-2020) in millimetric wave is opening new opportunities for the FS. 3GPP is proposing a new RAT (Radio Access Technology) called NR (New Radio), which is currently expected to support RF channel sizes up to 400 MHz. In order to foster deployment of NR, the Services & Systems Aspects (SA), a technical specification sub-group within the 3GPP, has established service requirements for in band-backhauling<sup>12</sup>. In order to fulfil these requirements, a study called “Integrated Access and Backhaul for NR”<sup>13</sup> was initiated by 3GPP SA with the goal of re-using the access spectrum for backhaul. This work is expected to be completed by June 2018.
- Value of IP/MPLS networking in mobile backhaul: The need for increased networking capabilities in any network domain is pushing an increased adoption of the IP/MPLS protocol suite. The use of IP/MPLS networking in the mobile backhaul and aggregation network brings a number of advantages to the overall solution:
  - IP/MPLS operates over any Layer 1 media or Layer 2 protocol, allowing a great deal of freedom to leverage available media types (e.g. copper, fibre and microwave) for cost-effective scaling.
  - IP/MPLS can operate efficiently over a wide variety of topologies (e.g. linear, tree mesh and ring) with consistent, rapid protection techniques. Flexible architectures and resiliency techniques bring improved network availability. IP/MPLS architectures are ready to offer point-to-point, and point-to-multipoint, Layer 2- and Layer 3-based transport, providing a seamless evolution path for the support of LTE.
  - Powerful management tools, based on both MPLS and Ethernet operations, administration, and maintenance (OAM) standards, provide visibility and proactive control at the link, connection and service levels. Common tool suites allow rapid deployment and service level agreement (SLA) validation for fast time to revenue.

<sup>12</sup> 3GPP TS 22.261, Service requirement for the 5G System, section 6.12.2 “Self backhaul”.

<sup>13</sup> 3GPP TSG RAN Meeting #75, RP-170831.

- IP/MPLS for 2G, 3G, and LTE transport: In 2G and 3G deployments, all mobile traffic is typically backhauled between the base station and the radio controller complex in a hub-and-spoke architecture. When evolving to LTE, to optimize the RAN architecture, the radio controller function is embedded in the enhanced Node B (eNB). Therefore inter-eNB communication may now be required during handoff for both control and data plane traffic, in addition to communication between eNBs and packet gateways at the mobile office. IP/MPLS can concurrently support a diverse set of networking capabilities including Layer 2 and Layer 3 virtual private networks (VPNs), which can be deployed to support the evolving business and technical requirements of the operator, on a common MPLS infrastructure.

#### **4.4 Gigabit millimetric-wave links**

##### **4.4.1 Capacity increase in millimetric-wave bands**

This section provides an example of the performance of gigabit millimetric-wave links. Millimetric-wave links are used for short-haul and high-capacity transmission because they use millimetric-wave bands and wide channel spacing. Their large bandwidth has been used to develop a high-capacity transmission system for mobile backhaul or local access networks that can transmit STM-4 (622 Mbit/s), or Gigabit Ethernet (more than 1 000 Mbit/s).

As of 2012, progress in high-speed devices has enabled the use of bands above 100 GHz for FS applications. Report ITU-R F.2107 describes a feasibility study of a 120 GHz band wireless link that employed ASK modulation scheme, and succeeded in transmitting 10-Gbit/s data over a distance of 5.8 km. 120-GHz-band wireless link equipment using QPSK modulation scheme has succeeded in 10-Gbit/s data transmissions over a short distance [10]. Moreover, 20-Gbit/s data transmissions using polarization multiplexing using orthomode transducer have been reported [11]. 10-Gbit/s bi-directional data transmission has been achieved by using 16×16-element planar slot array antenna shown in § 4.2.1 [12].

Studies of over-10 Gbit/s wireless transmission using millimetric-wave bands have been underway since 2010. Figure 25 shows the data rates of experimental millimetric-wave wireless links reported in various technical papers. Most of these reports described feasibility studies of indoor millimetric-wave wireless links. Various types of over-10 Gbit/s wireless links have been reported, and this trend has become significant since 2010.

These improvements in the millimetric-wave wireless link shown in Fig. 25 were achieved by the introduction of high-order modulation scheme or the increase of bandwidth available with the use of higher frequency bands. These technologies are expected to be introduced into FWS in the near future. Gigabit operation in the 57-64 GHz range using high gain directional antenna arrays is also capable of providing multiple gigabit operation in support of point-to-point links using technologies such as IEEE Std 802.11ad.

FIGURE 25

Data rates of experimental millimetric-wave wireless links

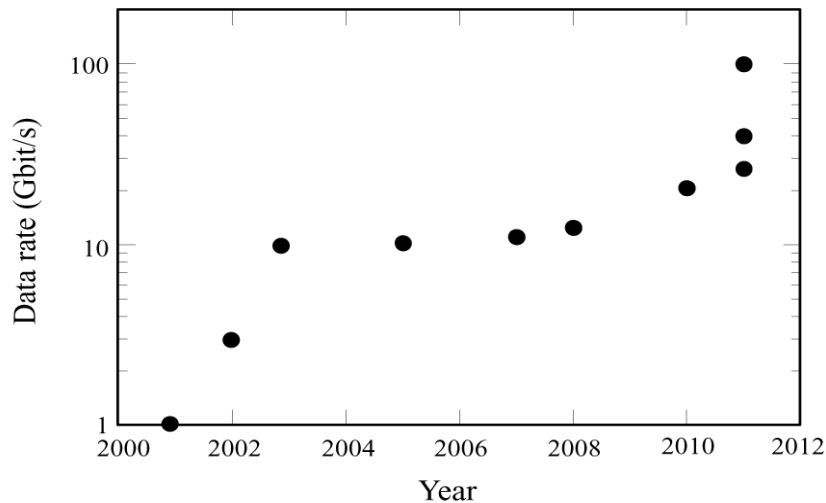

#### 4.4.2 Equipment simplification technology for high capacity transmission

This section also provides an example of a system of gigabit millimetric-wave links using the impulse radio (IR) technology which allows more advanced equipment. The IR technology is much suitable to achieve gigabit class communication in higher portion of certain millimetric wave bands, where wider bandwidth is available.

The IR technology is based on an ultra-short pulse generator and eliminates the need of an up-or-down converter composed of oscillators, multiplier/mixer, which is used in the conventional radio technology. Moreover, this technology allows simplified configuration, facilitating size reduction, lower power consumption and lower latency [13].

Figure 26 shows a conceptual diagram of the IR technology. Impulse is very short pulse in time domain and wide-band (>100 GHz) discrete spectrum in frequency domain. In the IR technology, adopted modulation scheme is simple On-Off Keying (OOK) (ON="1", OFF="0") and in the transmitter, an impulse signal responding to the input "1" is generated by using the ultra-short pulse generation.

A band pass filter (BPF) limits transmit signals in the selected band. For example, when a transmitter frequency band is that of 80 GHz (81 to 86 GHz), the BPF bandwidth is set 5 GHz. In the receiver, "1" signal is detected using envelopes of the received wave packet. This technology might have further interest for bands above higher frequency band e.g. 120 GHz or more.



FIGURE 26  
Principle of Impulse Radio Technology

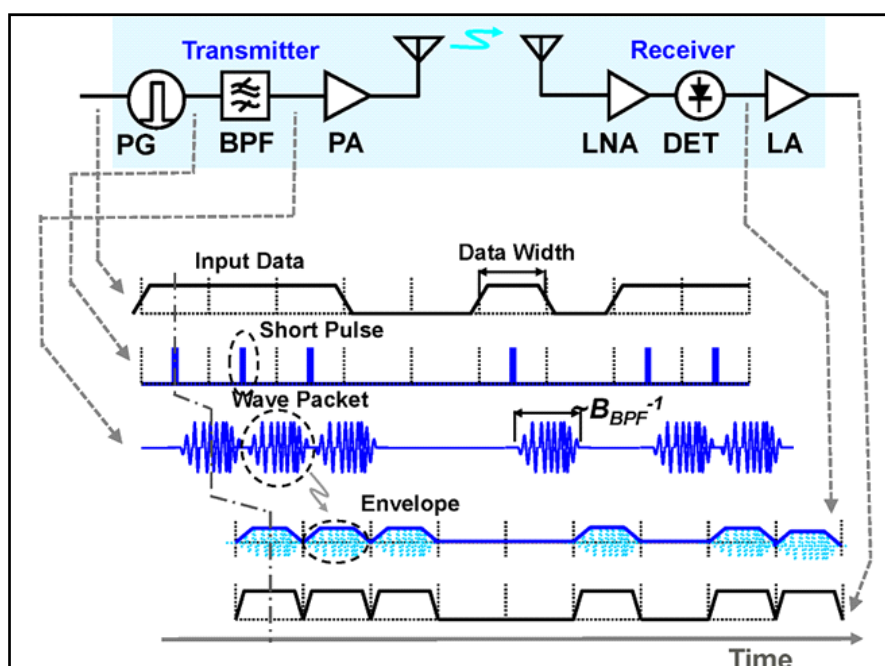

An example of systems using the IR technology in 70/80 GHz band is shown in Annex 2. This example may be appropriate for developing similar systems in higher frequency bands in the future.

#### 4.5 Propagation considerations

Because many FWS are point-to-point and use a line-of-sight link; it is important to consider the propagation model of point-to-point, line-of-sight links. Recommendation ITU-R P.530 provides guidance on prediction methods for the propagation effects that should be taken into account in the design of digital fixed line-of-sight links, both in clear-air and rainfall conditions, using the characteristics of rainfall given in Recommendations ITU-R P.837 and ITU-R P.838. It also provides link design guidance in clear step-by-step procedures, including the use of mitigation techniques to minimize propagation impairments. For the assessment of interference between the FS and other terrestrial services in the same band, Recommendation ITU-R P.452 should be used.

In order to plan and carry out interference assessment involving fixed service links in bands above 50 GHz, in particular, the 70/80 GHz and 90 GHz bands, the propagation characteristics regarding these bands are required. It has been noted that while there are some experimental data sets for the bands above 50 GHz, Recommendations ITU-R P.530, ITU-R P.837 and ITU-R P.838 can be used for this purpose. Regarding Recommendation ITU-R P.452, for evaluating interference between the FS and other terrestrial services in bands above 50 GHz, clear air conditions should be considered, as worst case, until this Recommendation is sufficiently tested for these bands. Therefore, further experimental data and studies would enhance these propagation models.

The frequency bands for FWS links cover the range from below 1 GHz to millimetric-wave (up to 95 GHz). The propagation characteristics of SHF and those of millimetric waves are quite different because free-space loss is proportional to the square of the operating frequency; therefore, the free-space loss in the millimetric-wave region is much higher than that in the SHF region. Report ITU-R F.2107 reports the relationship between the attenuation (dB/km) and the frequency (GHz) of radio waves due to gases and rain for radio transmission through the atmosphere. Figure 27 shows the attenuation due to gasses and hydrometeors for transmission through the atmosphere. In the SHF

region, gaseous and rain absorptions are negligible. The rain attenuation becomes significant in the millimetric-wave bands, and the rain attenuation of millimetric-waves (over 30 GHz) becomes over 20 dB/km when the rain rate is 150 mm/hr. Moreover, a large oxygen-related absorption is observed at 60 GHz (~10 to 15 dB/km). These differences in propagation characteristics affect the transmission distance of FWS. The typical transmission distance for FWS from 5 to 10 GHz exceeds 30 km. The typical transmission distance in the millimetric-wave region is below 10 km, and that over 60 GHz becomes a few kilometres.

FIGURE 27

Attenuation due to gasses and hydrometeors for transmission through the atmosphere

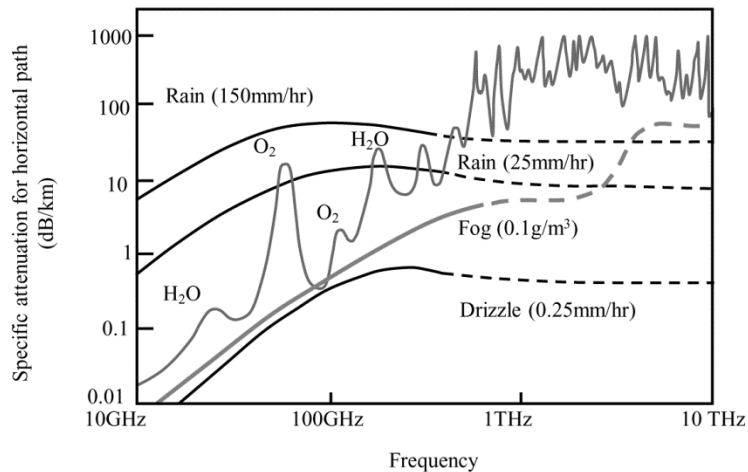

Recommendation ITU-R P.2001 predicts path loss due to both signal enhancements and fading over the range from 0% to 100% of an average year. The model covers the frequency range from 30 MHz to 50 GHz, and distances from 3 km to at least 1 000 km.

In the millimetric-wave region, the free-space loss is large, and high-gain antennas are used to compensate for it for FWS use. Moreover, millimetric waves travel straight and are hardly diffracted. These propagation characteristics enable us to prevent harmful interference, such as co-channel interference, when these wireless links are set up in a small area. Moreover, the use of polarization multiplexing also enables us to set two links using the same frequency bands close to each other. The effectiveness of space division multiplexing and the polarization multiplexing in millimetric-wave FWS has been reported [14]. Space division multiplexing is a method by which radio transmission media are physically separated by space in order to maintain channel separations.

Some FWS may use non-line-of-sight (NLoS) and quasi-non-line-of-sight (QNLoS) links. The propagation models for these conditions are evaluated using Recommendation ITU-R P.1411 and the applicable frequency bands of this Recommendation are below 20 GHz for the moment. According to recent studies, however, there are possibilities that this applicable frequency band can be extended up to 30 GHz and further studies are required.

#### 4.6 Future technologies

In order to catch up with the significant increase in data traffic, data rates of over 10 Gbit/s will be required for future FWS.

One of the ways to achieve these data rates is to introduce into the wireless link a digital coherent detection technology developed for optical links. Digital coherent detection technology is used in combination with digital signal processing, which allows for spectrally efficient modulation

formats such as QPSK and multi-level QAM, to be used to generate higher-speed data signals with bit rates of up to 112 Gbit/s [15]. The use of digital coherent detection technologies enables feasibility studies of wireless multigigabit-per-second data transmission.

A successful 40-Gbit/s 16-QAM indoor data transmission experiment using digital coherent technologies has already been performed [16]. In this experiment, the 40 Gbit/s 75-110 GHz band 16-QAM wireless signals were generated by an optical set-up consisting of a dual-parallel Mach-Zehnder modulator (DPMZM), dual-polarization QPSK modulator (DP-QPSK), and uni-traveling carrier photodiode (UTC-PD). They succeeded in the 40-Gbit/s data transmission over a distance of 30 mm.

Moreover, 100 Gbit/s indoor data transmission over a 75-110 GHz band wireless link was experimentally demonstrated [17]. The transmitter also used optical signal generation technologies. The use of dual-polarization multiplexing of 75-110 GHz band wireless signal doubled the transmitted data rate to 100 Gbit/s.

Various feasibility studies of indoor multi-gigabit-class data transmission using millimetric waves have been reported since 2011. At 200 GHz frequency bands, there are several reports with different approaches. Monolithic microwave integrated circuit (MMIC)-based transmitters and receivers for a THz-wave wireless link have been reported. One example is a successful demonstration of a Digital Video Broadcasting – Cable (DVB-C) transmission at 220 GHz reaching 15 Gbit/s with error-free transmission [18].

Non-line-of-sight and portable and mobile applications have also been tested in the 24-thru-40 GHz bands in 2013 [19].

Concern for energy savings and environmental protection are increasing. To begin addressing this the European Union has issued a Directive on Energy Efficiency with a target of a 20% reduction of gas emissions from 1990 levels, a 20% increase of energy consumption from renewable resources, and a 20% improvement in the EU's energy efficiency. This emerging trend is motivating radio manufactures and network operators to continuously explore future technologies in order to bring improvements in the entire network infrastructure. The GreenTouch Consortium, which has grown to include 53 vendors, carriers and research institutions since it was initiated by Alcatel-Lucent in 2010, has the stated objective to make wireless and wireline networks 1 000 times more energy efficient than they currently are. It is now widely recognized that the microwave packet approach will significantly minimize the energy requirements of future networks.

Another way to increase the data rate of FWS is to use terahertz (THz) waves. In general, the data rate increases with the carrier frequency, and it is expected that the data rate of 10~100 Gbit/s can be achieved by using carrier frequencies of 100 to 500 GHz even with a simple modulation format like amplitude shift keying (ASK) and phase shift keying (PSK).

Finally, it is noted that WRC-19 agenda item 1.15 consists of an on-going study for the potential identification of frequency ranges within 275-450 GHz for FS applications. Studies are also being carried out under Question ITU-R 257/5. Based on WRC-19 agenda item 1.15 and Question ITU-R 257/5, Report ITU-R F.2416 has been developed which intends to provide the technical and operational characteristics of the FS applications operating in the frequency range 275-450 GHz and will be useful for the sharing and compatibility studies between the FS applications and the already identified passive services in this frequency range.

## **5 Spectrum aspects and requirements**

As seen in this Report, FS continues to play a significant role in providing various telecommunication networks/services including key backhaul connectivity for a number of applications. Due to a variety and nature of these applications, access to frequency bands within the range up to 95 GHz will

continue to be required for the foreseeable future. The bands within this range have their own particular characteristics making them suitable for different types of applications within the FS.

The bands below 3 GHz are suitable for various applications including use in remote areas; applications in these bands would likely to remain small in number and capacity offered but hardly replaceable.

The bands within the range 3-10 GHz are suitable for long distance link applications (e.g. long-haul trunking or high capacity, relatively long connection in mobile networks between large exchange centres of different cities where network latency and other economic factors are key considerations).

The bands within the range 10-43 GHz provide medium range links which are used for applications ranging from mobile backhaul to access networks. The demand for these bands will likely remain very high and with increasing capacity links also considering that the need for new typology of mobile base stations (e.g. small cells layer) would actually increase the demands (in number and capacity) for the current base stations (so called “macro” sites to which small cells BSs are generally connected)

The bands above 43 GHz have larger bandwidths but short links making greater frequency reuse efficiency. In these bands, also the economic aspect it is of utmost importance if large deployment is sought for the mobile backhauling; the cost of an expected large link density for very short hops network should cope with the cost target of the small cells base stations, which most operators expect to be an order of magnitude less than present base stations types. That means that also the cost of the backhauling (both in term of equipment and frequency usage rights) should be comparably lowered.

Furthermore, demand for high data rates is requiring larger channel bandwidths in bands below 40 GHz (channel separations up to about 112 MHz are provided by ITU-R Recommendations above 17 GHz) as well as increasing interest in the exploitation of higher bands well above 40 GHz for FS (e.g. 92 GHz / 120 GHz).

These different requirements and applications are expected to place varying demand on these bands and it is important to recognise and identify these requirements through appropriate measures so that spectrum availability is sufficiently catered for in various spectrum related discussions.

There is increasing interest in the use of frequencies above 100 GHz, as they will enable capacities in the 40 Gbit/s range over hop distances of about a kilometre [20]. Technologies are being investigated and regulatory studies are examining channel arrangements and deployment scenarios in the 92-114.5 GHz and 130-174.8 GHz frequency ranges [21]. CEPT, for example, has studies underway to facilitate the deployment of fixed services links in the frequency blocks already allocated to fixed services<sup>14</sup>.

## 5.1 Evolving deployment scenarios

Documented and funded government network, commercial network, public safety and community network construction plans are now placing unprecedented pressures on the FS. In particular, some evolving scenarios may require different technical parameters, e.g. elevation angles, with respect to conventional assumptions. However, due to larger number of links expected overall costs should be considered; license exempt or light license options should also be considered. In addition, the planning of conventional “licensed” links should be carefully considered in low height (street level) urban environment where reflection/diffraction effect may become predominant.

---

<sup>14</sup> CEPT ECC WG SE19, Work items SE19\_37 and SE19\_38, available at: <http://eccwp.cept.org/default.aspx?groupid=45>.

### 5.1.1 Small cell backhauling

Small cells will be built on the order of anywhere from 5 small cells per 1 macro cell (in rural areas) to 20 or more small cells per 1 macro cell (in urban areas). These small cells will all require backhaul, and the technical and economic factors surrounding those necessary backhaul deployments require that a significant percentage will require high QoS licensed fixed service connections provided that the cost of the license is affordable for that business case.

### 5.1.2 Urban links scenarios

Urban LoS, nearly LoS and NLoS links (e.g. for small cells) backhauling represent a challenging deployment from the point of view of FS performance prediction and related propagation scenarios. Presently ITU-R propagation recommendations have not yet considered in detail these specific deployment scenarios e.g.:

- a) FS NLoS links normally use relatively high gain antennas, which are generally not considered in recommendations developed for mobile deployment scenarios.
- b) Even LoS links in the expected cases of street-to-street and roof-to-street deployment will be affected by multipath interference due to reflections on buildings and clutter elements; therefore, while the “main path” could still be planned with the conventional link-by-link methodology, the expected interference might be addressed with a statistical approach.

### 5.1.3 Machine to Machine (M2M)

In addition to the small cell networks that are being built, a vast array of M2M applications are being brought to the market. These applications will result in unprecedented high volume interactions from fixed and mobile locations, many featuring low profile (i.e. small, lightweight) yet high broadband capacity capabilities. These networks will also require backhaul, and due to economic and technical characteristics, the fixed service will necessarily need to be utilized to satisfy a meaningful percentage of the backhaul connectivity.

### 5.1.4 Physical diversity

As more critical infrastructure requirements become more reliant on broadband systems, the contract requirements will make certain to de-leverage sole reliance on wireline backbone and backhaul infrastructures. Fixed wireless, with its physical-diversity and independently-powerable characteristics, will fill a meaningful percentage of those contract requirements.

### 5.1.5 Long haul broadband

There are proven, emerged digital broadband fixed wireless technologies that can and will supplement, extend or replace long-haul broadband wireline systems due to economic, technical, or speed-to-market advantages. Superior spectrum reuse capabilities in the wide-area licensed 24, 26, 28, 31 and 39 GHz bands allow for 200 or more links per square kilometre. The emerging small cell and M2M requirements only further expand this movement to these bands. By offloading capacity in these bands, the lower bands can be more thoroughly dedicated to either mobile or long-haul uses.

## 5.2 Capacity and spectrum requirements

Although there has been an order of magnitude increase in mobile capacity requirements and new spectrum being sought for mobile broadband applications over the last decade, it is currently too early to tell definitively how the overall corresponding fixed service spectrum requirements are likely to change in the future. As broadband network topologies change and capacity requirements increase a corresponding shift to higher capacity fixed links will also become necessary, potentially placing more challenges on the available spectrum, particularly in hot spot areas. Advances in technology and different architectures such as ‘C-RAN’ and ‘Fronthaul’ where baseband data is transported could

also lead to significant step changes in the amount of data being required to be transported via a given link (e.g. 10 GBits / s and possibly higher), leading to wider channels and increased spectrum use. NLoS systems could also become a more significant feature of network planner's requirements with the associated spectrum being necessary to be identified. These areas all require further study in order to better quantify the changing spectrum requirements for the future.

In addition the other aspect to the spectrum question is the corresponding current spectrum supply for the fixed service and whilst currently spanning a wide range of bands from the UHF frequencies up to the higher millimetric wave bands this could also change in the future depending on the new applications or services that are looking for access in the higher bands, currently used by fixed service systems. For example mobile broadband systems are currently being considering in a range of bands above 6 GHz which may impact the availability of the spectrum for the FS in the future. This may be partly mitigated by advances in technology enabling the fixed links to correspondingly increase throughput and reliability and the addition, of new fibre projects that have increased fixed station access, in urban and suburban locations, obviating the need for previous fixed backhaul from those locations. However, it still currently remains uncertain how these will develop in different regions of the world and the associated impact on the spectrum used by fixed service systems. Further uncertainty is added to the determination of spectrum requirements as not all of the spectrum allocated to the Fixed Service in the Radio Regulations may be practical or available for such use on a national basis due to a number of different reasons; for example, the spectrum may already be used by other services or may not be suitable for a variety of technical and/or spectrum management reasons. If administrations can make this already internationally allocated spectrum available for use by fixed service systems, for example, by introducing increased or new sharing approaches, it may ease national spectrum requirements. Further study is required into this taking into account that increased use of new or enhanced sharing techniques to improve overall spectrum utilisation also applies across other allocated services.

### **5.3 Spectrum assignment and economical impact on small cells FS backhauling**

The success of small cells deployment depends on an affordable business case for the operators. The expected urban deployment density of base-stations for small cells (micro/pico cells) is an order of magnitude higher than that of the present base-station (macro cells); also the handled capacity would be correspondingly lower. Logically the target cost for a small cell deployment should be lower of about one order of magnitude; the overall cost includes the base-station itself, the backhauling equipment and the spectrum cost. While the hardware cost could be managed by technology and large scale production, the cost of the spectrum may need further consideration.

## **6 Future subjects for the development of FWS applications**

Future subject for the development of FWS applications are considered from the view of the following elements:

- Applications.
- Band usage including licensing regimes.
- Technologies.

### **6.1 Applications**

A FWS is used in telecommunication networks in various situations such as transport or trunking networks, mobile backhaul, FWA systems and temporary use.

Increase of mobile backhaul will become dominant among these applications because introducing mobile terminals such as smartphones which generate explosive traffic requires much more capacity

for mobile backhaul. This expected growth in mobile backhaul will require the smaller cell size of base stations so that their density will increase. Consequently, the trends of smaller cell sizes result in shorter hop and the use of smaller/integral and/or adaptive antennas.

## 6.2 Band usage

In order to catch up with the recent explosive traffic increase for the mobile backhaul, increasing capacity of FWS is required. However, frequency resources are tight, especially in the SHF region and improvements to spectrum efficiency are required. Although a hop distance is much shorter than that of SHF bands as described in § 4.3, wider bandwidth can be used in millimetric-wave bands than SHF bands.

Millimetric-wave bands will be important frequency bands for mobile backhaul because required hop distance for mobile backhaul will become smaller for certain cases as mentioned above.

Long hop distance of mobile backhaul will be still required, and for such the purpose, SHF bands will occupy important position in FS. Therefore, it is important to estimate how much the demand will increase for each FS application and to analyse the impact on frequency spectrum management (e.g. available bandwidth, system capacity requirements, channel reuse schemes, possible sharing with other services) in both millimetric-wave and SHF bands.

Another point of band usage is an asymmetric assignment plan. Downlink traffic towards subscribers is usually 3-4 times higher than uplink traffic and asymmetric assignment plans are discussed in some mobile applications. Taking into account these facts, applying asymmetric assignment plans to mobile backhaul will be possible.

As for the spectrum use, it is found that the number of links in all frequency bands has increased in most of countries and the growth in the higher frequency bands is remarkable. This trend is essential for the demand of the mobile backhaul network and expected to continue for coming years.

From the viewpoint of regulatory regimes, protecting spectrum is essential and usual licensing is basically required to use spectrum. However, under some circumstance, other regulatory regime such as light-licensing is available and this licensing regime enables rapid installation of FWS and protecting spectrum, and drive deployment of FWS. To achieve it, for examples, following items should be studied.

- Sharing and compatibility study with other services.
- Technical and economical spectrum access conditions.
- Propagation characteristics.
- In-band backhauling.

## 6.3 Technologies

Higher-level QAM such as 1024-QAM improves capacity of FWS. However, even 1024-QAM (10 bits/symbol) increase data rate only by 1.25 compared with 256-QAM (8 bits/symbol) and then increasing modulation level does not seem effective to achieve higher capacity. To achieve higher capacity of FWS, wider bandwidth and channel bonding technologies are needed for FWS. Promising alternative is also the spatial reuse (MIMO) for the higher bands. Long distance transmission of mobile backhaul will still be required as described in the part of Band usage. When using millimetric-wave bands, in order to build long-distance transmission, a large number of repeater stations are necessary, which necessitate a reduction of size and cost of repeater stations. Exploration of higher frequency bands, such as over 100 GHz, is important in preparation for the future shortage of millimetric-wave band resources. To make practical use of these frequency bands, it is necessary to develop inexpensive RF devices, propagation models and antenna pattern models that cover the frequency region over 100 GHz.

In addition, the future subjects regarding technologies used in FWS includes:

- Link design enhancement when the joint use of ATPC and AM/ACM.
- New links topology including ITU-T G.8032v2 networking.
- Payload Management (including traffic prioritization) taking into account the progressive evolution of the radio traffic from TDM to Packet traffic.
- Urban deployment of street-level FS stations for Line of Sight (LoS), Non Line of Sight (NLoS) or Quasi Line of Sight (QLOS) small cells backhaul.
- IP/MPLS networking in mobile backhaul.
- Inter-base station communication.
- Combining frequencies used for fixed service backhaul with the mobile service.
- Channel aggregation in same or different frequency band (Band and Carrier Aggregation (BCA)).

## 7 Conclusions

The importance of FWS is increasing in transport or trunking networks, macro and small-cell mobile backhaul networks, FWA systems, Machine-to-Machine (M2M), temporary FS including physical-diversity and disaster recovery links and ENG. In addition, evolving deployment scenarios are also emerging. The success of small cells deployment depends on an affordable business case for the operators. The expected urban deployment density of base-stations for small cells (micro/pico cells) is an order of magnitude higher than that of the present base-station (macro cells).

Increases in speed and reliability of links are required for FWS in many applications, and moreover, the use of millimetric-wave bands is spreading in order to achieve gigabit-class data rates and to solve the scarcity of frequency resources.

NLoS and portable and mobile technologies for the FWS bands are being deployed in certain test environments [22]. Further technological progress is, e.g. on use of antenna array beamforming, are required to achieve long distance transmission for gigabit-class and 10-gigabit-class communications.

Moreover, establishing overviews of frequency spectrum management is important in order to achieve optimum allocation of scarce frequency resources and also to recognize and identify through appropriate measures the different and changing requirements for applications in the FS. In the same way, alternative ways to assign and share spectrum, in order to facilitate implementation and meet the needs of the users/operators should be considered.

## Annex 1

### Applications making use of FWA technology

While FWA systems are designed as access networks, such equipment can be also used for various other applications. Figure 28 depicts examples of such applications.



FIGURE 28

Examples of applications making use of same equipment as FWA

(a) Bridging two local/private area networks between separate buildings

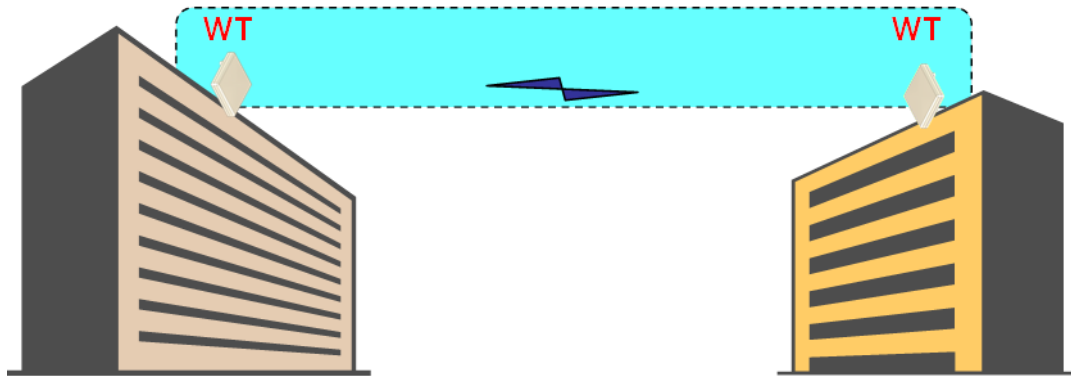
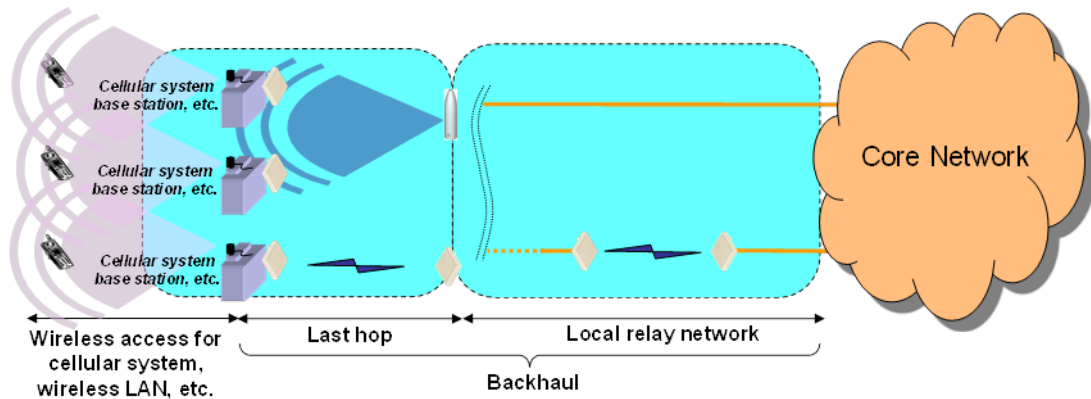
(b) P-P and P-MP backhaul<sup>15</sup>

(c) Machine type communications

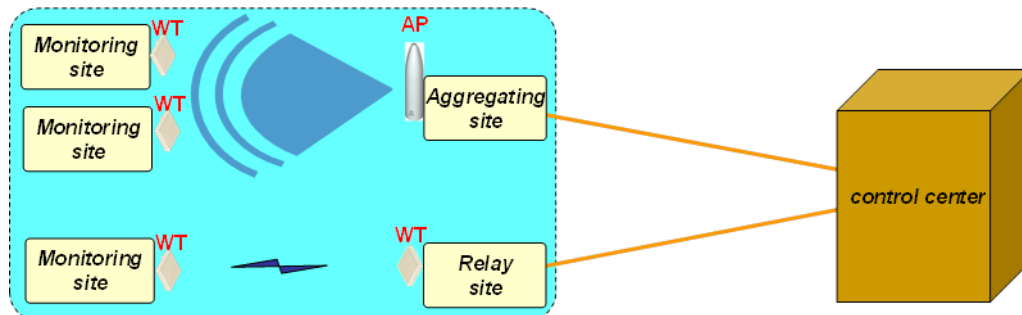

<sup>15</sup> Fixed service, millimetric band, point-to-multipoint systems are in the marketplace and additional systems are under development:

- (i) Federal Communications Commission (FCC) Radio Station Authorization, Call Sign: WPOH633: <http://wireless2.fcc.gov/UlsApp/UlsSearch/license.jsp?licKey=8653>
- (ii) [https://apps.fcc.gov/oetcf/els/reports/STA\\_Print.cfm?mode=current&application\\_seq=60763&RequestTimeout=1000](https://apps.fcc.gov/oetcf/els/reports/STA_Print.cfm?mode=current&application_seq=60763&RequestTimeout=1000)

(d) Home networks connected to FWA systems

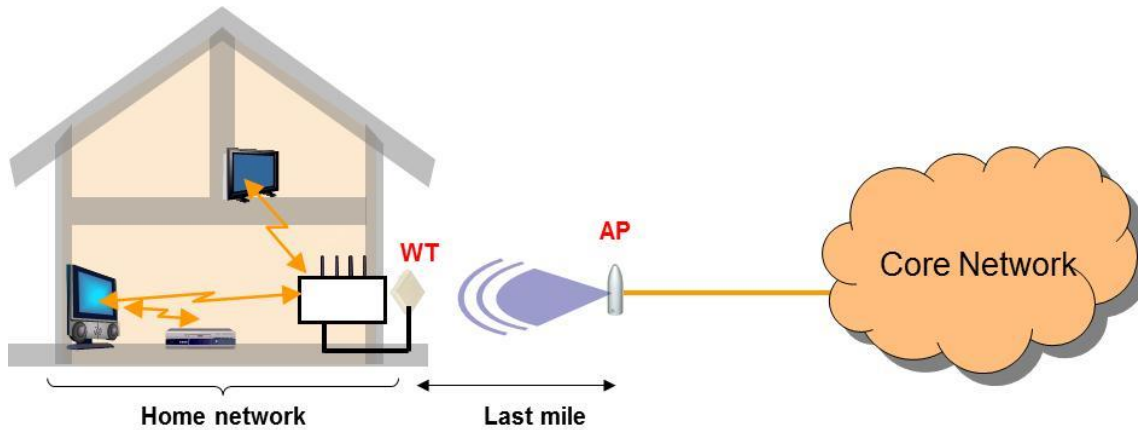

One example of such application is to bridge two local/private networks between separate buildings. These networks are usually IP-based networks and sometimes operated by private entities. A link bridging networks using FWA systems can be installed rapidly and economically making use of the advantage aspects listed in § 2. Additionally, as demand for IP communication increases same as the demand for ordinary FWA systems, broadband IP communication interfaces are also required for this application

Another example is for the last mile of mobile backhaul. The demand for mobile backhaul is expanding to support new mobile services such as LTE technology. These services provide each user with higher data transmission rates than the previous mobile technologies with the result that the last hop also requires broadband transmission. Moreover, these services are expected to be provided in many cases using very small cell-sizes, therefore there may be many more base stations in a given area. There can be anywhere from 5-to-20 small cells deployed in the future for every macro-cell base station [2]. As a result, each base station must be more compact, light-weight, and economical than conventional ones, including the supporting backhaul, equipment. Broadband FWA systems can satisfy these requirements of compact size, light-weight and economical design.

The same equipment as FWA can also be used for machine type communications (MTC) such as wide-area sensor and/or actuator networks (WASN) (see Recommendation ITU-R M.2002). As for MTC, wireless is useful in easily and rapidly constructing temporary networks or constructing permanent networks where it is difficult to lay wires, e.g. rivers, marshes, and deserts. As a recent trend, networks connecting to a control centre and service areas must provide higher capacity to support emerging applications, such as video monitoring systems, all of which require broadband communications. Broadband FWA systems also satisfy these requirements with their features of broadband transmission, and compact size, light-weight and economical design which achieves easy and flexible installation.

The above-mentioned applications making use of FWA equipment have already been deployed in some areas. Some examples of these deployments are shown in Figs 22 through 25. In these examples, products of Wireless IP Access System (WIPAS) are used. The system parameters of WIPAS are shown in Table 4.

TABLE 4  
System parameters of WIPAS

Items	Specification
Frequency band	25.27-26.98 GHz
Occupied bandwidth	52 MHz
Transmission scheme	TDM, TDMA, and dynamic TDD
Transmission power	AP: Max. 27 dBm, WT: Max. 14 dBm
Symbol rate	40 Mbaud
Payload rate	Approximately 180 Mbit/s (total of down and uplink)
Modulation mode	64-QAM, 16-QAM or QPSK (Adaptive modulation supported)
Priority queuing	8 class QoS (POTS-quality VoIP supported)
Multicast	HDTV video signal multicast supported
Antenna Type / Gain	AP: Omni-directional antenna / 5 dBi, etc., WT: Planar antenna / 31.5 dBi
Propagation distance	P-P: Max. approximately 7 km / P-MP: Max. approximately 2 km
Application services	Internet, POTS-quality VoIP and HDTV

WIPAS is basically designed to provide wireless broadband services. Figure 29 shows a deployment example of broadband services in Japan. The technology is also available in the United States of America.<sup>16</sup> The broadband service using WIPAS is provided in some areas where FTTH service is difficult to be introduced.

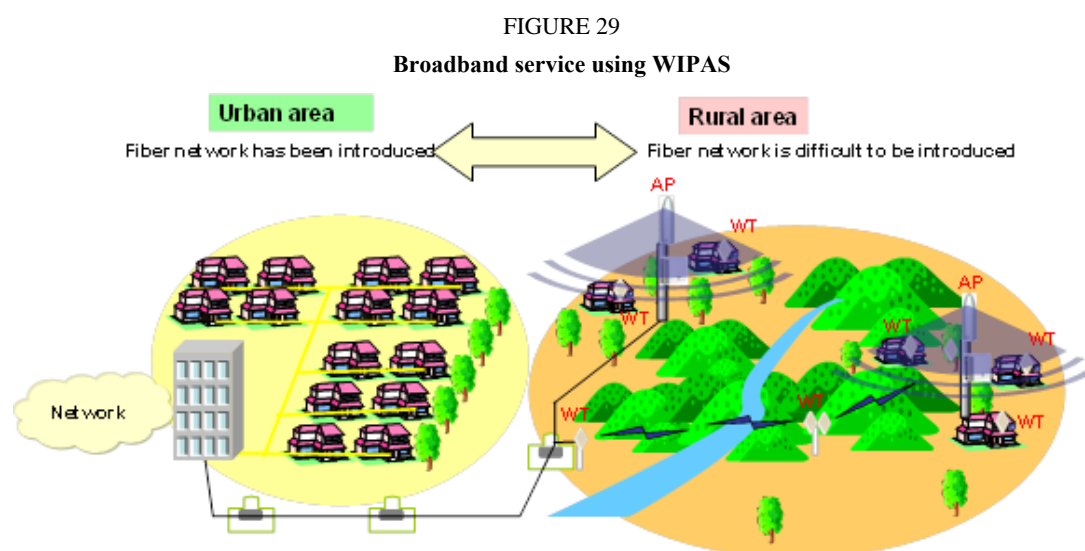

Figure 30 presents a deployment of mobile backhaul to provide an Internet access service for passengers in the trains on Tsukuba Express Line in Japan. In this example, WIPAS is adopted as backhaul forming access links between the radio-relay stations along the rail track.

<sup>16</sup> [http://www.jrcamerica.com/download/WIPAS\\_Spectrum\\_in\\_US.pdf](http://www.jrcamerica.com/download/WIPAS_Spectrum_in_US.pdf).

FIGURE 30  
Backhaul for Internet access service in moving trains

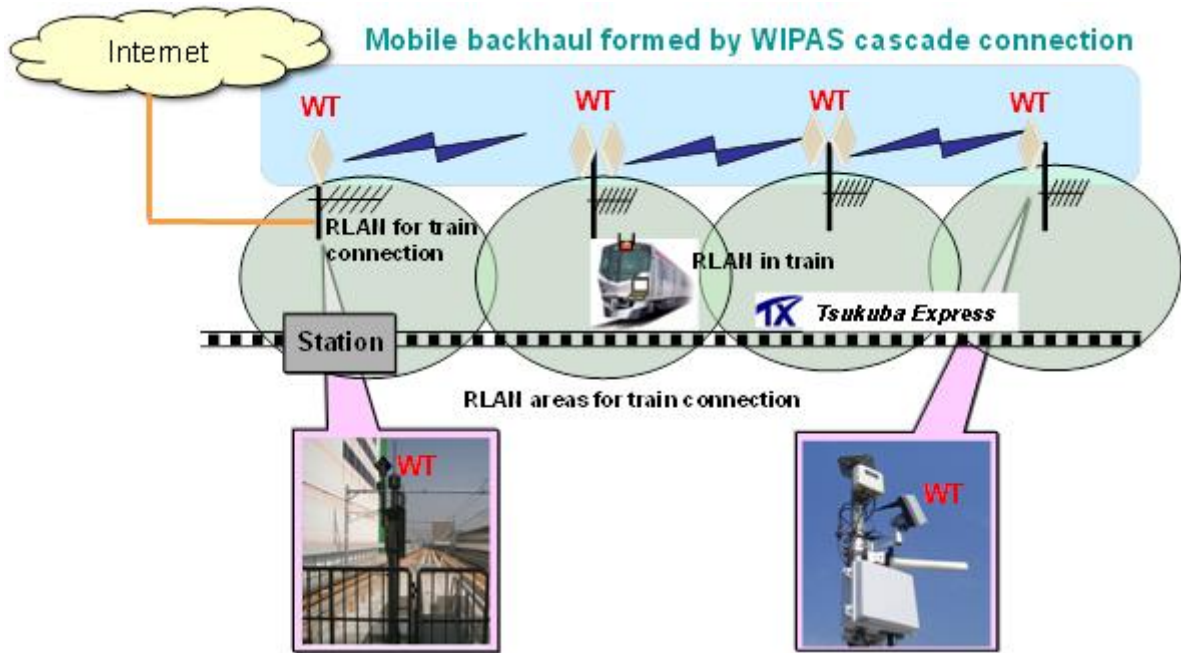

Figure 31 depicts an example of MTC applications, which is a remote monitoring system that enhances safety and efficiency in an open-pit mine in Chile. The application field of this MTC deployment model is expected to be further expanded to other industries, such as the construction industry.

FIGURE 31  
Example of MSC applications

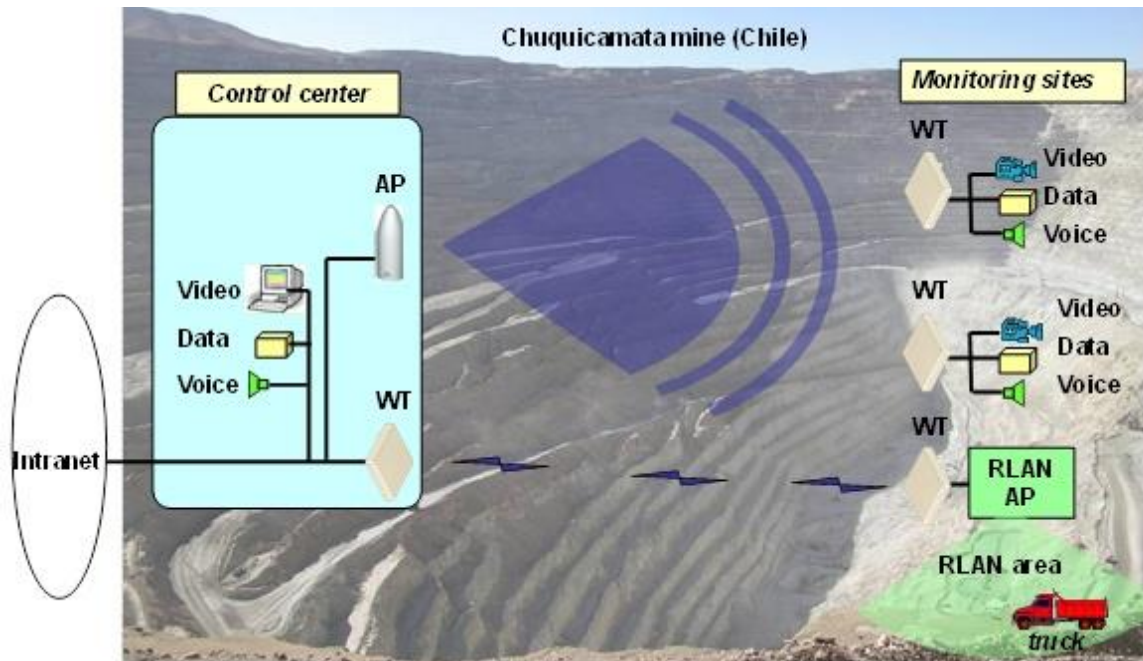

Figure 32 shows an example of a wireless link using WIPAS for emergency response, which was used at the mine roof collapse site in Chile. A WIPAS point-to-point system connected the rescue office to one of the drilling sites, located 300 metres apart. A wired link would have taken too long time to set up and would have been prone to damage.

FIGURE 32  
Example of a wireless link using WIPAS for emergency



Source: Adapted from graphics on BBC News website ([http://www.bbc.co.uk/news/special\\_reports/chile\\_mine/](http://www.bbc.co.uk/news/special_reports/chile_mine/))

Besides these examples, WIPAS is also being utilized in Indonesia. A wireless broadband network connecting a university, a local ICT centre, and several high schools has been constructed by WIPAS point-to-point connections.

WIPAS has the excellent benefits of high-speed/broadband data transmission, high reliability and flexible installation and so can satisfy various telecommunication demands of many application types around the world.

Another application for home networks connected to FWA systems that can be considered as an extension of FWA systems, is shown in Fig. 28 (d). One example of such applications is a gigabit link using millimetric wave which has an ability to transmit high definition video data. Usually, such a gigabit links can be used for high capacity transmission inside the home.

The 60-GHz band, which is a license-exempt band in many countries, has a wide bandwidth of 9 GHz making it an ideal candidate for such gigabit link systems. A wideband antenna/RF module used in the home network has been developed [23] (see Fig. 33). The antenna and BPFs, which are passive components, are formed in a multi-layer low-temperature co-fired ceramic (LTCC) substrate. The amplifiers, frequency converters and frequency multipliers, which are active components, have been developed as monolithic microwave integrated circuits (MMICs) and are mounted on the back side of the antenna as shown in Fig. 34. The module is  $12 \times 12 \times 1$  mm in size. The antenna uses a microstrip antenna structure with stacked rings [24].

The measured maximum absolute gain of the fabricated antenna is 10.5 dBi. The antenna/RF module has the measured conversion gain of more than 10 dB over the entire 9-GHz bandwidth. The transceiver using the antenna/RF module can transmit uncompressed HD videos at a transmission rate of 3.8 Gbit/s per channel. The antenna/RF module can also be applied to the transceiver for a non-contact data transmission system [25].

FIGURE 33  
 Photograph of the antenna/RF module

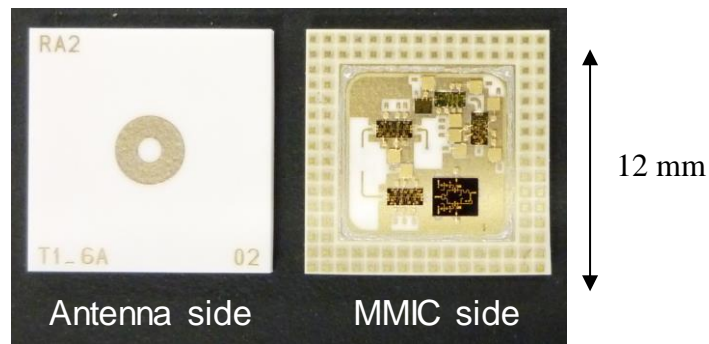

## Annex 2

### Example system using the IR technology described in section 4.4.2

The appearance of the equipment using the IR technology in the 70/80 GHz band (E-band) is shown in Fig. 34. This equipment is an all-in-one integrated transmitter/receiver intended for outdoor use that has a user interface. Channel spacing is 5 GHz in the 70/80 GHz band and 3 Gbit/s transmission is achieved in the up and down streams respectively. Adopting the IR technology has enabled a simpler circuit configuration, which has led to achievement of compact, light weighted and low-power consumption equipment. The antenna size and type is selectable depending on transmission distance, circuit availability and rainfall condition. Typical available distances are 1 km for 1-foot parabolic antenna and 3 km for 2-foot parabolic antenna. Table 5 shows parameters of the system.

FIGURE 34  
 Appearance of the equipment using the IR technology

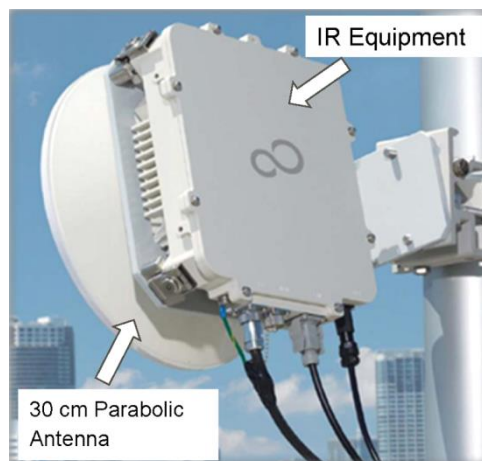

TABLE 5  
System parameters

Items	Parameters
Frequency band	71-76/81-86 GHz
Throughput	3.0 Gbit/s
Transmission power (peak)	+17 dBm
Line Interface	Ethernet (10 GbE, GbE) CPRI (2.4 Gbit/s)
Latency	Ethernet: 77 $\mu$ s CPRI: 18 $\mu$ s
Operations and maintenance	Remote: SNMP Local: Local Terminal
Power consumption	25 W
Volume	3 Litre
Weight	< 3.0 kg
Antenna size and gain	30 cm (1FT): 43 dBi 60 cm (2FT): 48 dBi

### Application examples

– Mobile access network

In case of newly introducing a mobile network such as IMT-Advanced/LTE/WiMAX backhaul, and interconnecting macro or small cells use of the E-band IR links could be beneficial in a number of ways, such as rapid deployment and relatively low establishment cost in comparison with installing a new fibre link. Especially in the mobile access network, E-band IR has interface in accordance with CPRI (Common Public Radio Interface) specification between remote radio head (RRH) and eNodeB.

– Inter-premise network (Intra-network in enterprise, etc.)

To construct a local area network within premises of an enterprise, E-band IR system allows a high-speed network instead of optical fibre link without construction across the road or over a river. Figure 35 shows an example.

FIGURE 35

Inter-premise network



- Live broadcasting  
When conducting a live broadcasting of events or such like, use of E-band IR systems as a temporary link eliminates the need of installing an optical fibre from the broadcasting site to the communication station building. In addition, the high-capacity transmission allows uncompressed high-definition video signals to be transmitted with low latency.
- Quicker disaster recovery from disconnected Optical Link  
When an optical fibre link is disconnected due to a disaster, E-band IR equipment installing as temporary link can recover traffic at an early stage.

### Annex 3

#### Example of field-trial on 18 GHz System using MIMO (Spatial Frequency Reuse) described in section 4.3

##### MIMO channel measurement experiment – Aims

A MIMO trial was set and tested in Spain in order to analyse Multi-Polarized 2×2 MIMO in LOS condition without any power constraint (i.e. the MIMO transmission power is double with respect to an equivalent SISO one). The selected carrier frequency is 18 GHz with channel separation (CS) = 55 MHz and the modulation format is 256-QAM. The frequency band was chosen due to the availability of an existing experimental SISO link which was upgraded to MIMO saving the installation of one of the two dual-polar antennas.

One of the main scopes of the experimentation was to proof the increase of the link capacity according to the MIMO theory.

##### MIMO channel measurement experiment – Configuration and plan

Figure 36 shows configurations and plans of the experiment. The optimal antenna distance ( $d_{opt}$ ) for MIMO operation, over a 6.2 km link hop length, is 7.1 m but for practical installation matter it was only possible to install antennas with 4.3 m of separation. The last value corresponds to the 60% of the optimal distance and it drives to around 4.5 dB drop in SNR gain.

The MIMO configuration is 2×2 plus CCDP (Co-Channel Dual Polarization) arrangement thus four (4) sub-channels were achieved.



FIGURE 36  
MIMO link details

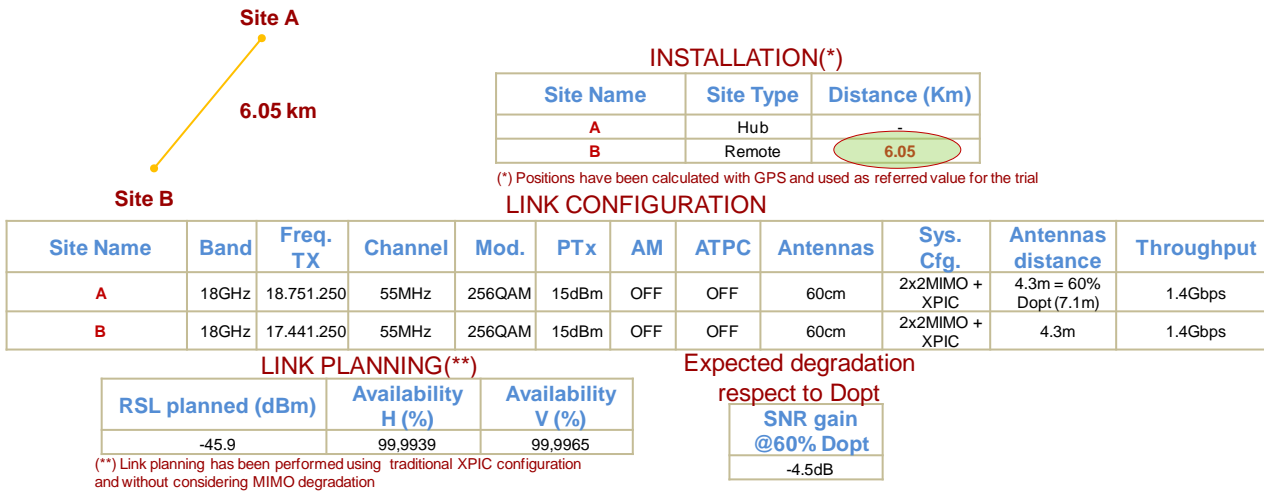

**MIMO channel measurement setup**

In Fig. 37 a sketch of the used MIMO setup is presented. It comprises: eight available ODUs and two IDUs with a new MIMO modem board, four dual-polarized 60 cm diameter dish antennas, a traffic generator/analyser instrument, a data logger, a weather station meter and laptop for controlling the link.

FIGURE 37  
MIMO link layout

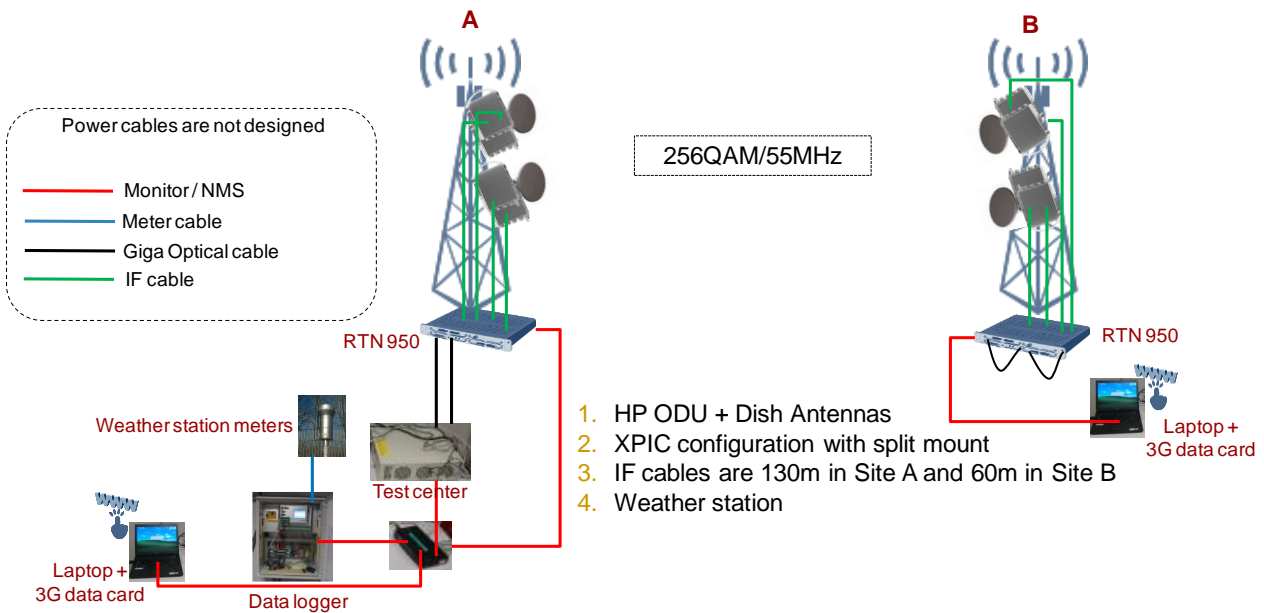

**Test results and analysis**

In the three layers of Fig. 38 are shown:

- The Received Signal Level (RSL) values for the four MIMO sub-channel in one direction. Due to many tolerance sources in the link setup the RSL values are not at the same level, anyway the RSL values for links with the same polarization are kept in a reasonable  $\pm 3$  dB spread.

- The Mean Square Error (MSE) values at RX side for the four MIMO sub-channel in one direction. For the four sub-channels the MSE evolutions are very irregular with an average level of 32 dB.
- The whole MIMO capacity. The resulting capacity measured was around 1.4 Gbit/s and it was quite stable during the recording time.

Considering that an average throughput for a SISO 256-QAM over 55 MHz CS system configuration is around 410 Mbit/s, MIMO capacity improvement results around 3.4 times the typical SISO capacity.

These results are a subset of the measurements performed during the experimental period, in particular just seven days registration is reported.

FIGURE 38  
RSL, MSE and Capacity results

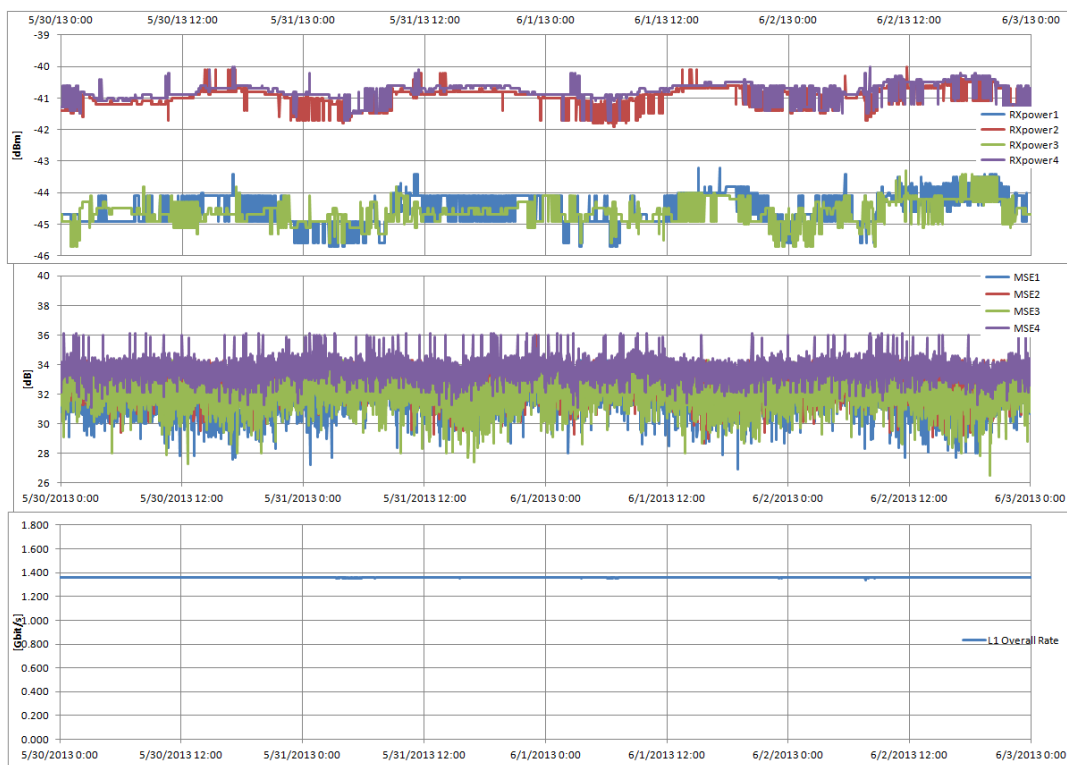

## Annex 4

### Experiments on large/massive MIMO technologies applied to FWSs

#### Aims

Experiments on basic characteristics for large/massive MIMO were performed in Japan in order to verify the potential of FWSs with large/massive MIMO as described in § 4.2.2.1.

#### System parameters

Figures 39 and 40 show the appearances of a central station and a mobile base station, respectively.

FIGURE 39  
Appearance of the central station (Receiver)

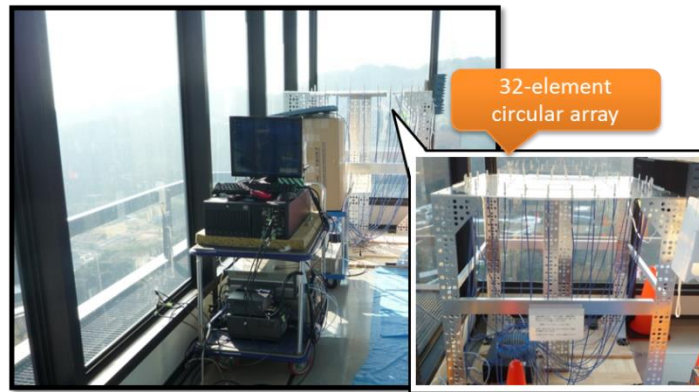
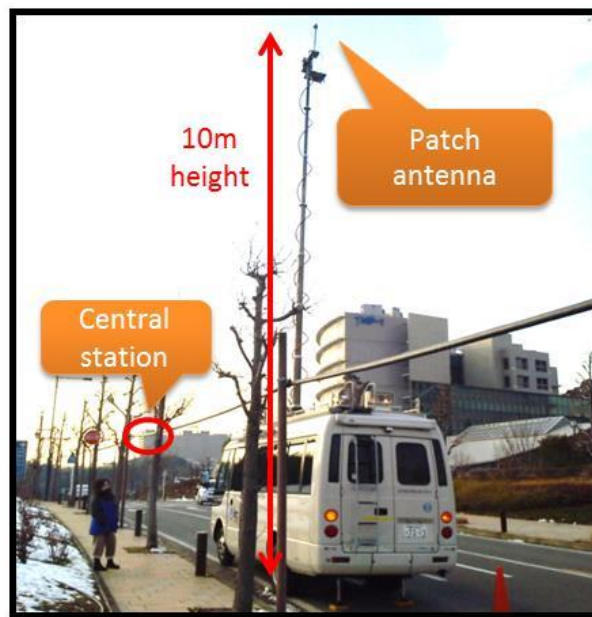

FIGURE 40  
Appearance of the mobile base station (Transmitter)



The central station had a 32 element circular antenna that was 45 metres high. Each element of the antenna was an omni-directional antenna with a 1 dBi gain and is placed every 2 wavelength spacing. The mobile base station had single patch antenna 10 metres high. As shown in Fig. 40, the experiments were carried out in a LOS environment between the antennas of the central station and the mobile base stations. The mobile base stations transmitted signals to the central station. Table 6 shows the parameters used.

TABLE 6  
Parameters used in the experiments

Parameters	Values
Carrier frequency	5.2 GHz
Bandwidth	20 MHz
Modulation	OFDM

TABLE 6 (end)

Parameters	Values
TX power (mobile base stations)	30 dBm
Transmitter (mobile base stations) antenna	Planar patch antenna Beamwidth: 87 degree Gain: 6.5 dBi
Receiver (central station) antenna	32 Omni-directional antennas Circular array with 2 wavelength spacing Gain: 1 dBi

## Results

Figure 41 shows a relationship between the received signal levels vs. distances. The blue and red points represent the total received signal levels and the combined signal level by large/massive MIMO, respectively. The results shown in Fig. 41 are for a single mobile base station transmitting signals to the central station; i.e. there was no interference from other stations. This Figure also shows that the diversity gain was 13.9 dB, which is very close to the theoretical value of 15.1 dB ( $=10 \log_{10}(32)$ ). These results show that diversity in large/massive MIMO systems worked very well. Moreover, the path losses in the experiments were subject to the free space propagation model.

FIGURE 41  
Received signal level and diversity gain

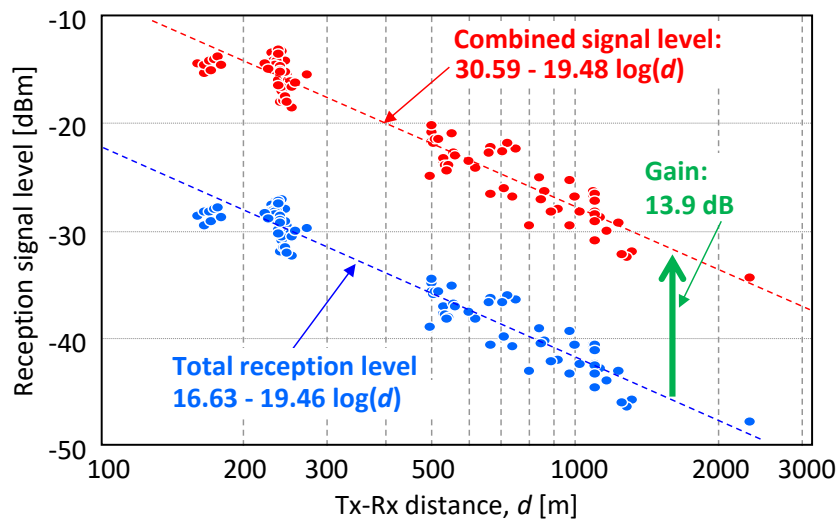
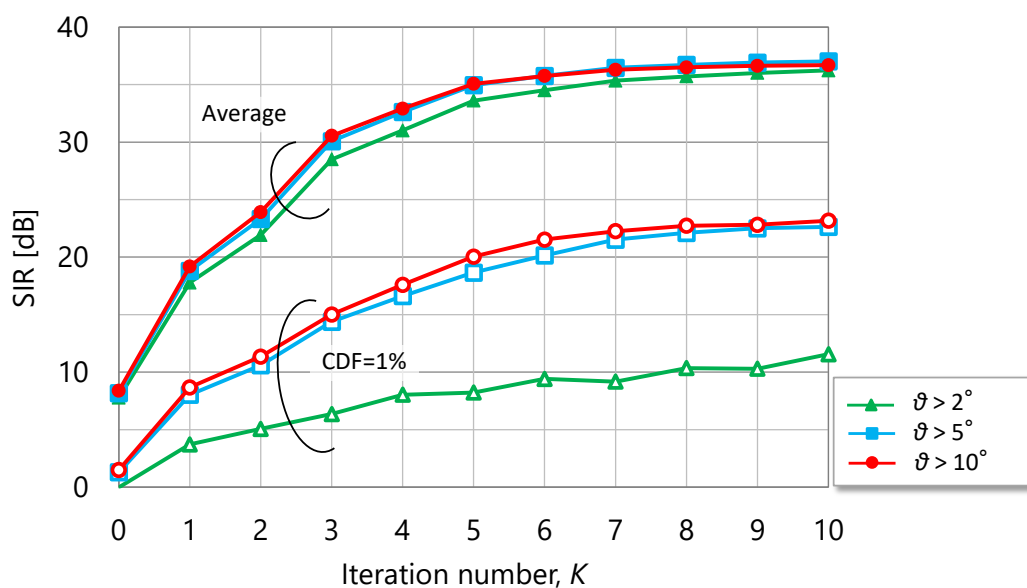

Figure 42 shows the ratios of the signal received from the desired mobile base station to the interference from the other mobile base stations (SIR). There were four mobile base stations and the measurement was made as a separation angles of  $\theta$  between the desired link path and the interference links path. That is, there was interference from 3 mobile base stations. The value of  $K$  is the parameter used in the algorithm to cancel out the interference from the other stations [26]. The large value of  $K$  becomes, more calculation volume is required to cancel out interference. This Figure shows that that SIR values of 35 dB (average) and 20 dB (CDF = 1%) are achieved for  $K = 5$  or more and separation angles of  $5^\circ$  or more. These results indicate that an FWS with large/massive MIMO can discriminate signals transmitted from four different mobile base stations even if they transmit signals simultaneously.

FIGURE 42  
SIR values

## Annex 5

### Experiments on 42-GHz-band system for 8K UHD TV broadcasting auxiliary service

#### 1 Introduction

In recent years, UHD TV broadcasting service is gradually becoming a norm. Since Recommendation ITU-R BT.2020 was published in 2012, UHD TV broadcasting services started in many countries via satellites, cables, and the Internet. Among others, broadcasting in “8K” format, or one that has the largest number of pixels in the UHD TV format, is scheduled to start in 2018 in Japan. As the number of UHD TV programmes is increasing, demand for new BAS including ENG that adapt to the UHD TV format is also increasing. One of the new BAS systems is a 42-GHz-band system developed in 2016, which is used to transmit 8K UHD TV video and audio signals from places such as sports venues and breaking news scenes back to broadcasting centre. The new system employs dual-polarized MIMO scheme with a wide bandwidth exploiting the nature of the millimetric-wave band, which enables a large transmission capacity of 600 Mbit/s that can cope with 8K signals. The system overview and the experiments are described in the following.

#### 2 System overview

Figure 43 shows the block diagram of the 42-GHz-band contribution link using dual-polarized MIMO scheme.

On the transmitter side, an input 8K UHDTV video and audio baseband signal is encoded and multiplexed into MPEG-2 Transport Stream by H.265/HEVC and MPEG-4 AAC encoder. In the modulator, the stream is split into two and a forward error correction encoding is applied on each stream, then OFDM modulation is performed to obtain two 400-MHz intermediate frequency (IF) signals, one for horizontal and the other for vertical polarization. The OFDM pilot signals are orthogonal between the two polarizations so that the MIMO detection can be performed on the receiver side. The radio frequency transmitter up-converts the IF signals to 42-GHz-band RF signals and amplifies them. The dual-polarized antenna radiates the two RF signals in respective polarizations with the cross-polarization discrimination around 30 dB.

On the receiver side, the process is reversed in principle except the MIMO detection is done in the demodulator.

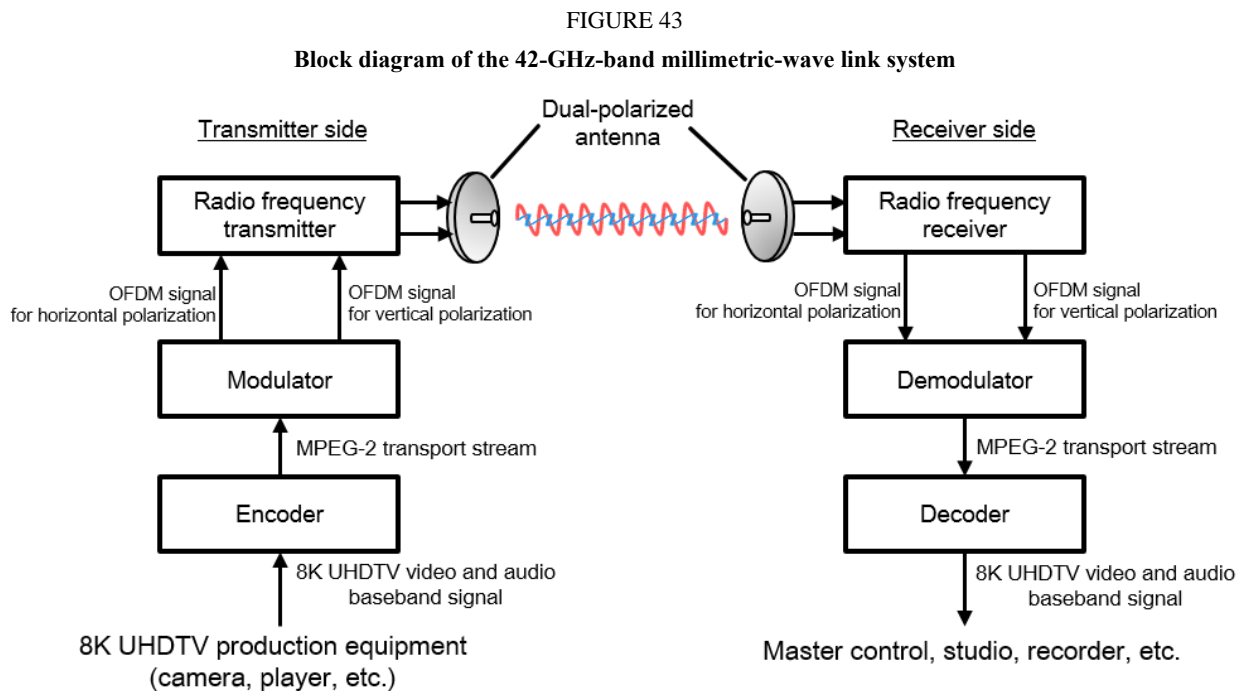

### 3 Proof-of-concept experiment

Based on Japan's standard (ARIB STD-B43), a proof-of-concept prototype of the 42-GHz-band contribution link was made, with a channel bandwidth of 62.5 MHz (occupied bandwidth of 54.4 MHz), which is the half bandwidth-size of the full standard. The system parameters of this proof-of-concept prototype are listed in Table 7. The subcarrier modulation of the OFDM signal is 16QAM. The error correction code is a concatenation of Reed Solomon code and convolutional code. The maximum transmission power is 250 mW. The achievable transmission rate is 160 Mbit/s.

TABLE 7

System parameters of proof-of-concept prototype

Transmission scheme	Dual-polarized MIMO-OFDM
Center frequency	41.03125 GHz
Occupied bandwidth	54.4 MHz (62.5-MHz channel bandwidth)
Subcarrier modulation	16-QAM

TABLE 7 (end)

Outer code	Reed Solomon code (204, 188)
Inner code	Convolutional code (code rate: 1/2)
Transmission power per polarization	100 mW / 250 mW
Bit rate	160 Mbit/s

Laboratory experiments were conducted using this prototype. The transmitter and the receiver were directly connected with waveguides through variable attenuators which were used to measure the bit error rate (BER) versus reception power.

Figure 44 plots the measured results of both polarizations when the transmission power is 100 mW and 200 mW. The Figure also plots the simulation results. Note that the BER is the one after inner code decoding. Taking into account that the required BER after inner code decoding, where the quasi error free is achieved after outer code decoding, is  $1 \times 10^{-4}$ , the minimum reception power to achieve quasi error free was  $-78.9$  dBm and  $-78.2$  dBm when the transmission power is 100 mW and 250 mW respectively. This reveals 1.7-dB degradation compared to the simulation result when the transmission power is 100 mW. This is because the simulation does not take into account the fixed-point implementation and analogue-circuit imperfections such as phase noise and distortion. Therefore, this degradation is considered to be reasonable particularly at this frequency range. Additional 0.7-dB degradation is observed when the transmission power is 250 mW, because the power amplifier generated more distortion. However, the transmission power can further be increased without a noticeable distortion by improving the device or introducing a distortion-compensation technique.

FIGURE 44  
BER versus reception power

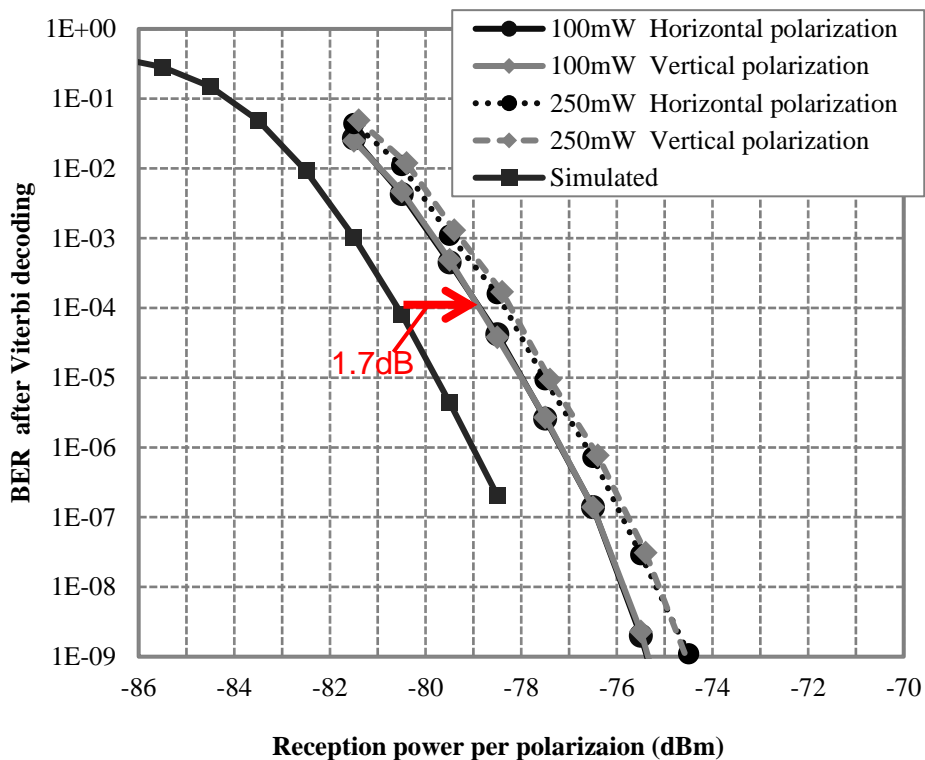

#### 4 Field experiment

For the field experiment, the channel bandwidth of the system was expanded to 125 MHz (occupied bandwidth of 109 MHz) in order to transmit 8K UHD TV signals, and as a result, the maximum transmission rate increased to 600 Mbit/s. The system parameters used in the field experiment are listed in Table 8. The transmission distance was approximately 8 km where the transmitting end was at the rooftop of NHK Broadcasting Center and the receiving end was chosen at the rooftop of NHK Science and Technology Research Laboratories (Fig. 45).

The 8K UHD TV video was successfully transmitted and decoded at the receiving end. The demodulator, the H.265/HEVC decoder, and the 8K UHD TV display used in this field experiment are shown in Fig. 46.

In addition, the continuous error free transmission over eight hours was achieved under a clear sky. Thus, the feasibility of the 42-GHz-band system for BAS was confirmed.

FIGURE 45

Overview of field experiment

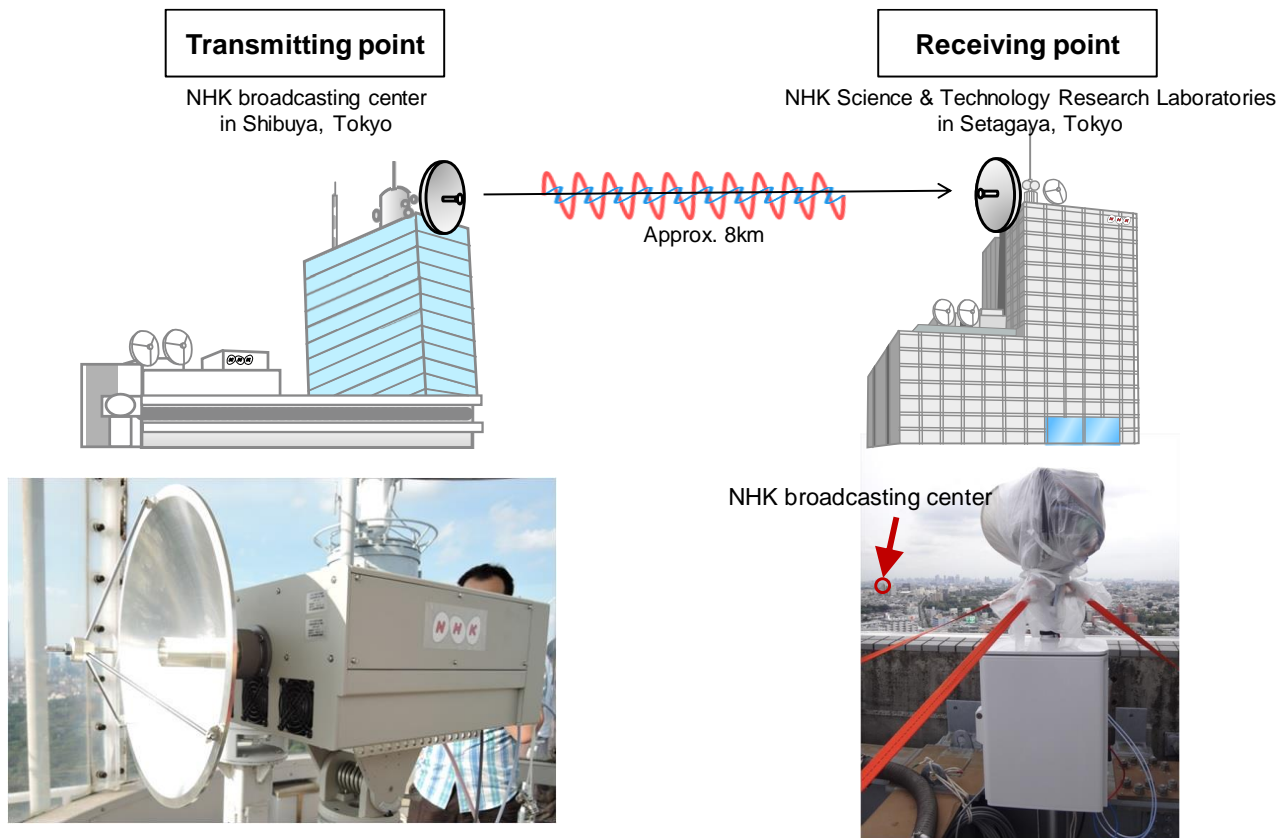

TABLE 8

System parameters of field experiment

Transmission scheme	Dual-polarized MIMO-OFDM
Centre frequency	41.0625 GHz
Occupied bandwidth	109 MHz (125-MHz channel bandwidth)
Subcarrier modulation	32 QAM
Outer code	Reed Solomon code (204, 188)
Inner code	Convolutional code (code rate: 3/4)

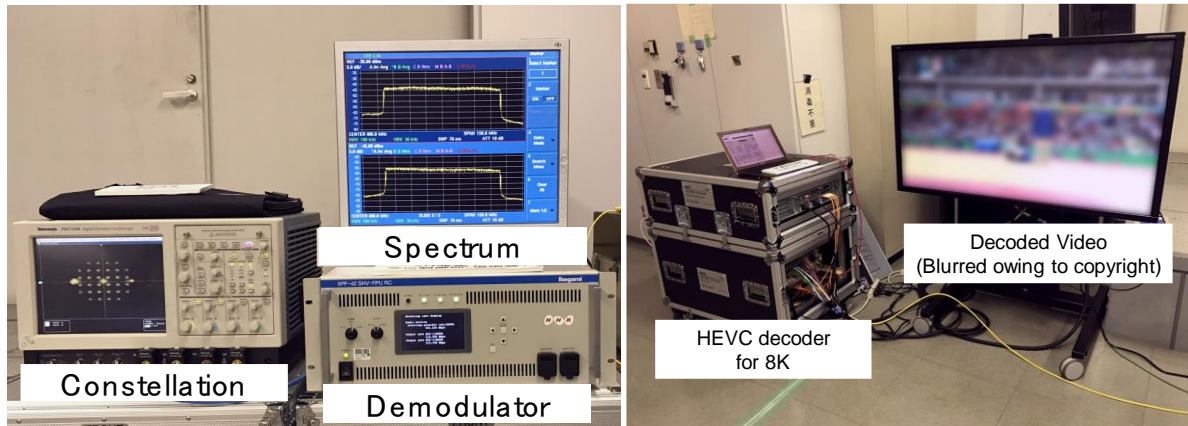

TABLE 8 (end)

Transmission power per polarization	250 mW
Transmitting and receiving antenna	$\phi$ 0.3 m dual-polarized Cassegrain antenna (Antenna gain: 40 dBi)
Bit rate	600 Mbit/s

FIGURE 46

Demodulator and H.265/HEVC decoder



## 5 Examples of link budget

Examples of link budget for the 42-GHz-band system are listed in Table 9. Having in mind that this millimetric-wave band is susceptible to rain attenuation, the nominal link distance is approximately 5 km at a rainfall rate of 20 mm/h, although the distance varies by the transmission parameters. However, by improving the antenna gain, increasing the transmission power, or adopting a higher-performance error correction code such as an LDPC code, the link distance may be extended up to 10 km. The link distance is considered to be sufficient in many cases, particularly for the operation in urban areas where the use of microwave-links is likely to be congested. And it is also important to note that a link distance of more than 40 km may be possible under the condition of clear sky.

TABLE 9

Examples of link budget

Transmission parameters (Subcarrier modulation, code rate and weather condition)	16QAM, 2/3 Rain: 20 mm/h	32QAM, 3/4 Clear sky	16QAM, 2/3 Clear sky
Transmission rate (Mbit/s)	430	600	430
Transmit frequencies $f$ (GHz)	42.0	42.0	42.0
Transmission output power $W$ (W)	0.25	0.25	0.25
Transmitting antenna gain $G_t$ (dBi)	40.0	40.0	40.0
Transmitting feeder loss $L_t$ (dB)	0.1	0.1	0.1
Effective radiated power ( $WG_t/L_t$ ) (dBm)	63.9	63.9	63.9
Transmission distance $d$ (km)	5.0	40.0	50.0
Free space propagation loss $(\lambda/4\pi d)^2$ (dB)	138.9	156.9	158.9

TABLE 9 (*end*)

Transmission parameters (Subcarrier modulation, code rate and weather condition)	16QAM, 2/3 Rain: 20 mm/h	32QAM, 3/4 Clear sky	16QAM, 2/3 Clear sky
Attenuation by atmospheric gases (dB) 0.2 dB/km (42 GHz)	1.0	8.0	10.0
Attenuation by rain (dB) 6.0 dB/km (42 GHz, rainfall rate 20 mm/h)	30.0	0.0	0.0
Required fading margin $F_{mr}$ (dB)	4.0	4.0	4.0
Receiving antenna gain $G_t$ (dBi)	40.0	40.0	40.0
Receiving feeder loss $L_r$ (dB)	0.1	0.1	0.1
Received power $C_i$ (dBm)	-70.1	-65.2	-69.1
Standard temperature $T_0$ (dBK)	24.8	24.8	24.8
Signal bandwidth $B$ (MHz)	109	109	109
Receiver noise figure $F$ (dB)	5.0	5.0	5.0
Receiver thermal noise $N_i = kT_0BF$ (dBm)	-88.4	-88.5	-88.5
Receiver thermal noise $C/N$ (dB)	18.3	23.3	19.3
Required $C/N$ (dB)	13.4	18.1	13.4
Transmission margin (dB)	4.9	5.2	5.9

## 6 Summary

Technical features of the 42-GHz-band BAS system which enables 8K UHD TV video and audio signal transmission were described along with its experimental results. By utilizing the wide bandwidth of this millimetric wave band and employing dual-polarized MIMO scheme, the transmission rate of 600 Mbit/s was achieved. In the laboratory experiment, BER versus reception power were measured and the results matched reasonably with the simulation. In the field experiment, the feasibility of the 42-GHz-band system for 8K UHD TV BAS was confirmed.

Consequently, the system parameters in Tables 7 and 8 in this Annex have been added in Japan's standard, ARIB STD-B43 – Portable Millimetre-Wave Digital Transmission System for Television Program Contribution, to facilitate the practical use of the 42-GHz-band 8K UHD TV BAS system.

## Annex 6

### Experiments on VHF (60 MHz) system for connecting rural areas

#### 1 Introduction

As described in § 2.1.2, very high frequency (VHF) bands may be attractive to fixed wireless systems (FWS) for transport networks of a long distance, because of relatively stable propagation conditions and lower diffraction loss than higher frequency bands. This Annex presents two cases of field-trials,

including line-of-sight (LoS) and near LoS<sup>17</sup>. Each field-trial of the two cases was conducted in Japan. Testbeds designed in VHF bands comprise base station (BS) and terminal station (TS), employing point-to-point (P-P) configuration, not point-to-multipoint (P-MP). For the trials, two types of testbed are employed. Case 1 employs a testbed of frequency division duplex (FDD). Case 2 employs a testbed of time division duplex (TDD).

## 2 Experiment results

### 2.1 Experiment results for distance of 67 km under LOS environments

This section shows Case 1, a feasibility study of a link whose distance is longer than 50 km. The testbed operates in FDD. Table 10 shows parameters of Case 1. Figure 47 shows the elevation profile in Case 1, where the LoS path is seen. Figure 48 shows antennas at BS and TS. The antenna of TS was placed on the rooftop of a building that is approximately 60 m in height. In this case, received power of approximately  $-95$  dBm was obtained. The testbed offered throughput of approximately 12.5 kbit/s, and one telephone line of the 8 kbit/s codec.

TABLE 10

**Parameters used in the experiment**

Parameters	Values
Frequency band	54.02-66.26 MHz
Channel bandwidth	13.7 kHz
Modulation	Single-Carrier, QPSK
Transmitted power	43 dBm (20 W)
Antennas at BS and TS	Three-element Yagi antennas with 6.3 dBi gain
Distance between BS and TS	Approx. 67 km

---

<sup>17</sup> This Annex defines the word “near LoS” as the case where obstacles block only Fresnel zones, not the actual line-of-sight.

FIGURE 47  
Elevation profile, with the distance of approx. 67 km

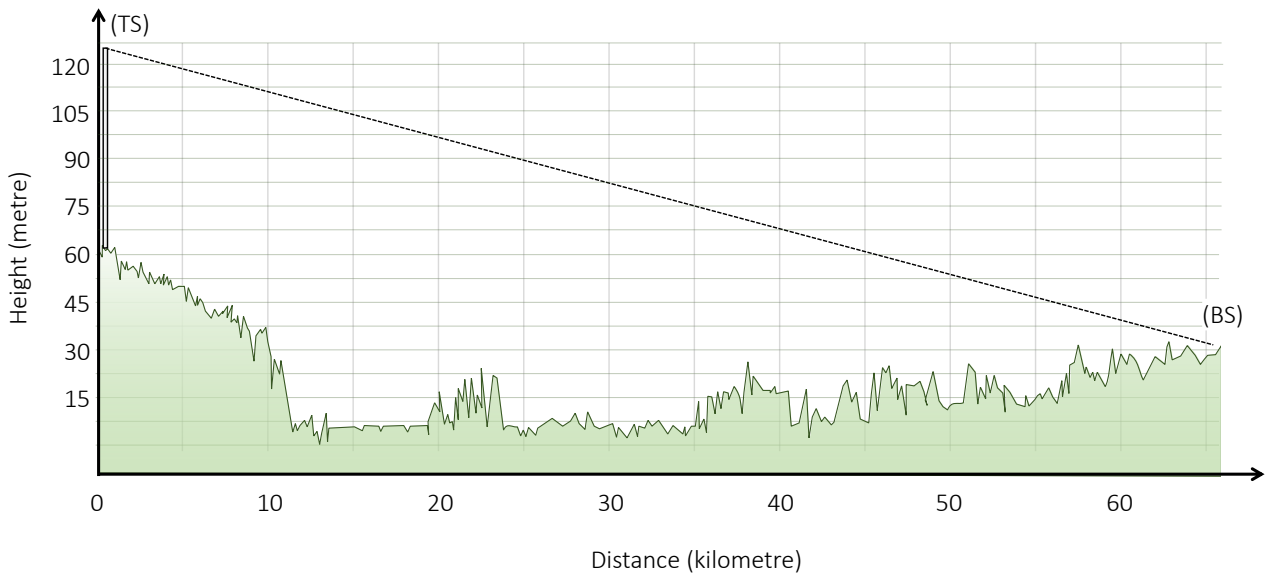

FIGURE 48  
Antennas at BS and TS



BS



TS

## 2.2 Experiment results for distance of 11 km under Near LOS environments

This section shows Case 2, a feasibility study of a link with near LoS and whose distance is longer than 10 km. The testbed operates in TDD. Table 11 shows parameters. Figure 49 shows the elevation profile in this case, where the near LoS path is seen. There exists an obstacle of the mountain ridge in the first Fresnel zone at the point of 4.5 km far from the BS. Figure 50 shows antennas at BS and TS. In this case, received power of approx.  $-62$  dBm was obtained. The testbed offered throughput of approximately 12.5 kbit/s, and three telephone lines of the 64 kbit/s codec.

TABLE 11  
Parameters used in the experiment

Parameters	Values
Frequency band	54.02-66.26 MHz
Channel bandwidth	110 kHz
Modulation	Single-Carrier, 64-QAM
Transmitted power	40 dBm (10 W)
Antennas at BS and TS	Three-element Yagi antennas with 8.15 dBi gain
Distance between BS and TS	Approx. 11 km

FIGURE 49  
Elevation profile, with the distance of approx. 11 km

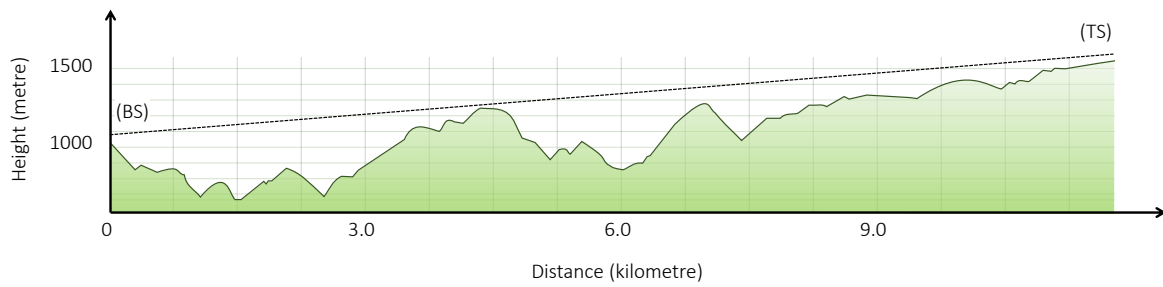

FIGURE 50  
Antennas at BS and TS



BS



TS

### 2.3 Summary

Based on the technical experiments, the actual operation of long-distance (approximately 50 km) FWS using the VHF band has been started in 2022 in Japan.

## References

- [1] HANSRYD J., and EDSTAM J., (January 2011) Microwave capacity evolution, Ericson Review (<http://www.ericsson.com/res/docs/review/Microwave-Capacity-Evolution.pdf>)
- [2] UMTS Forum Report 44: Mobile Traffic forecasts 2010-2020, January 2011. ADELSTEIN, J., KRUFKY, K., TURNER, P. and SANDRI, J., "Small Cell Acceleration," July 2013 (<http://www.thedasforum.org/wp-content/uploads/2013/07/HetNet-Forum-Small-Cell-Acceleration-Seminar-Presentations.pdf>)
- [3] EDSTAM, J., "Microwave Backhaul gets a boost with multiband", Ericsson Technology Review, 25 January 2016;  
Available: [http://www.ericsson.com/res/thecompany/docs/publications/ericsson\\_review/2016/etr-multiband-booster-bachhaul.pdf](http://www.ericsson.com/res/thecompany/docs/publications/ericsson_review/2016/etr-multiband-booster-bachhaul.pdf)
- [4] MONZINGO, R. and MILLER, T., "Introduction to Adaptive Arrays," published by John Wiley & Sons Inc., 1980.
- [5] WANG, K., AZAR, Y., WONG, G., MAYZUS, R., ZHAO, H., SCHULZ, K., SUN, S., SAMIMI, M., GUTIERREZ F. and RSPAPORT, T. S., "28 GHz Angle of Arrival and Angle of Departure Analysis for Outdoor Cellular Communications using Steerable-Beam Antennas in New York City," IEEE Vehicular Technology Conference (VTC), June 2013.
- [6] ZHANG M., HIROKAWA J. ANDO M. (October 2010). Design of a Partially-Corporate Feed Double-Layer Slotted Waveguide Array Antenna in 3-9 GHz Band and Fabrication by Diffusion Bonding of Laminated Thin Metal Plates. IEICE Trans. Communication., Vol. 93, pp. 2538-2544.
- [7] HIROKAWA J., Kim D., ANDO M., NAGATSUMA T., TAKEUCHI J., and HIRATA A., (March 2013), Wideband Waveguide Slot Array Antennas with Corporate-feed in 120 GHz and 350 GHz bands, 2013 International Symposium on Electromagnetic Theory (EMTS 2013), 24AM1C-6.
- [8] KIM D., HIROKAWA J., ANDO M., TAKEUCHI J., HIRATA A. (2014) 64×64-element and 32×32-element slot array antennas using double-layer hollow-waveguide corporate-feed in the 120 GHz band. IEEE Transactions on Antennas and Propagation, Vol. 62, No. 3, pp. 1507-1512.
- [9] ARAI T., OHTA A., SHIRATO Y., KUROSAKI S., MARUTA K., IWAKUNI T., and IIZUKA M., "Antenna Array Arrangement for Massive MIMO to Reduce Channel Spatial Correlation in LOS Environment," IEICE Trans. Communication Vol. 100, pp. 594-601, October 2016.
- [10] TAKAHASHI H., KOSUGI T., HIRATA A., TAKEUCHI J., MURATA K., KUKUTSU N., (2013) 120-GHz-Band 10-Gbit/s Fully Integrated Wireless Link using Quadrature-Phase-Shift Keying, IEEE International Microwave Symposium, WE3F-5.
- [11] TAKEUCHI J., HIRATA A., TAKAHASHI H., KUKUTSU N., (2012) 20-Gbit/s unidirectional wireless system using polarization multiplexing for 12-ch HDTV signal transmission, Asia-Pacific Microwave Conference, pp. 142-144.
- [12] HIRATA A., TAKEUCHI J., KIM D., HIROKAWA J., 10-Gbit/s dual channel transmission of 120-GHz-band wireless link using planar slot array antennas (2013) European Microwave Conference, pp. 744-747.
- [13] NAKASHA, Y., SATO, M., TAJIMA, T., KAWANNO, Y., SUZUKI, T., TAKAHASHI, T., MAKIYAMA, K., OHKI, T., and HARA, N., "W-band Transmitter and Receiver for 10-Gb/s Impulse Radio With an Optical-Fiber Interface", IEEE TRANSACTIONS ON MICROWAVE THEORY AND TECHNIQUES, VOL. 57, No. 12, December 2009, pp. 3171-3179.
- [14] HIRATA, A., TAKEUCHI, J; TAKAHASHI, H., KUKUTSU, N., NISHIKAWA, H., IRINO, A., NAKAYAMA, T., and SUDO, N., (October 2011)" Space division multiplexing of 120-GHz-band wireless links using high-gain antennas," European Microwave Conference, pp. 25-28.
- [15] WINZER P., GNAUCK A., DOERR C., MAGARINI M., and BUHL L. (February 2010), Spectrally efficient long-haul optical networking using 112 Gbit/s polarization-multiplexed 16-QAM. IEEE J. Lightwave Technology, Vol. 28, pp. 547-556.

- [16] KANNO A., INAGAKI K., MOROHASHI I., SAKAMOTO T., KURI T., HOSAKO I., KAWANISHI T., YOSHIDA Y. and KITAYAMA K. (2011), 40 Gb/s W-band (75-110 GHz) 16-QAM radio-over-fiber signal generation and its wireless transmission. European Conference and Exhibition on Optical Communication (ECOC). pp. 1-3.
- [17] Pang X., Caballero A., Dogadaev A., Arlunno V., Borkowski R., Pedersen J S., Deng L., Karinou F., Roubeau F., Zibar D., Yu X., and Monroy I. T. (November 2011), 100 Gbit/s hybrid optical fibre-wireless link in the W-band (75-110 GHz). *Optic Express*, Vol. 19, pp. 24944-24949.
- [18] KALLFASS I., ANTES J., LOPEZ-DIAZ D., DIAZ S., DIEBOLD S., MASSLER H., LEUTHER A., and TESSMANN A. (November 2011). All active MMIC based wireless communication at 220 GHz. *IEEE Trans. Terahertz Science and Technology*, Vol. 1, pp. 477-487.
- [19] HANSRYD, J., EDSTAM, J., OLSSON, E., and LARSSON, C., "Non-line-of-sight microwave backhaul for small cells," *Ericsson Review*, 22 February 2013, ([http://www.ericsson.com/res/thecompany/docs/publications/ericsson\\_review/2013/er-nlos-microwave-backhaul.pdf](http://www.ericsson.com/res/thecompany/docs/publications/ericsson_review/2013/er-nlos-microwave-backhaul.pdf)).
- [20] ERICSSON, "Microwave towards 2020 – Delivering High-Capacity and Cost-Efficient Backhaul for Broadband Networks Today and in the Future", September 2015. Available: <http://www.ericsson.com/res/docs/2015/microwave-2020-report.pdf>
- [21] Carpenter, S. He, Z., Bao, M., and Zirath, H., "A Highly Integrated Chipset for 40 Gbps Wireless D-band Communication Based on a 250 nm InP DHBT Technology", published in Compound Semiconductor Integrated Circuit Symposium (CSICs), 2014 IEEE. Abstract available: <http://ieeexplore.ieee.org/xpl/articleDetails.jsp?arnumber=6978535>
- [22] AZAR, Y., WONG, G., WANG, K., MAZYZUS, R., SCHULZ, J. ZHAO, H. GUTIERREZ, F., HWANG, D. and RAPPAPORT, T., "28 GHz Propagation Measurements for Outdoor Cellular Communications using Steerable Beam Antennas in New York City", the 2013 IEEE International Conference on Communications (ICC), June 9-13, 2013. ([http://faculty.poly.edu/~tsr/Publications/ICC\\_2013\\_28.pdf](http://faculty.poly.edu/~tsr/Publications/ICC_2013_28.pdf))
- [23] KAWASHIMA M., SEKI T., HIRATA A., and KOSUGI T., (2011) Millimetre-wave/terahertz circuits and transceivers for broadband wireless systems, in Proc. The 54th IEEE International Midwest Symposium on Circuits and Systems (MWSCAS 2011), pp. 1-4.
- [24] SEKI T., HIRAGA K., NISHIKAWA K., and UEHARA K., (2009) 60-GHz Microstrip Antenna with Stacked Rings using Multi-Layer LTCC Substrate, in Proc. The 3rd European Conference on Antennas and Propagation (EuCAP 2009), pp. 3797-3800.
- [25] NAKAGAWA T., SEKI T., KAWASHIMA M., TSUBAKI T., HIRAGA K., SHIMIZU M., and UEHARA K., (April 2013) Concept of and transceiver for a 60-GHz high-speed non-contact transmission system, in Global Symposium of Millimetre Waves 2013 (GSMM2013) Proc., paper M3-2.
- [26] MARUTA K, OHTA A., KUROSAKI S., ARAI T., IIZUKA M., "A Novel Application of Massive MIMO: Massive Antenna Systems for Wireless Entrance (MAS-WE)," IEEE International Conference on Computing, Networking and Communications (ICNC), February 2015.
- SONG H., KIM J., AJITO K., YAITA M., KUKUTSU N., (July 2013) Fully Integrated ASK Receiver MMIC for Terahertz Communications at 300 GHz, *IEEE Trans. Terahertz Science and Technology*, vol. 3, Issue 4, pp. 445-452.

### Related ITU-R Recommendations and Reports

Recommendation ITU-R F.382	Radio-frequency channel arrangements for fixed wireless systems operating in the 2 and 4 GHz bands
Recommendation ITU-R F.383	Radio-frequency channel arrangements for high-capacity fixed wireless systems operating in the lower 6 GHz (5 925 to 6 425 MHz) band
Recommendation ITU-R F.384	Radio-frequency channel arrangements for medium- and high-capacity digital fixed wireless systems operating in the 6 425-7 125 MHz band

Recommendation ITU-R F.385	Radio-frequency channel arrangements for fixed wireless systems operating in the 7 110-7 900 MHz band
Recommendation ITU-R F.386	Radio-frequency channel arrangements for fixed wireless systems operating in the 8 GHz (7 725 to 8 500 MHz) band
Recommendation ITU-R F.387	Radio-frequency channel arrangements for fixed wireless systems operating in the 10.7-11.7 GHz band
Recommendation ITU-R F.497	Radio-frequency channel arrangements for fixed wireless systems operating in the 13 GHz (12.75-13.25 GHz) frequency band
Recommendation ITU-R P.530	Propagation data and prediction methods required for the design of terrestrial line-of-sight systems
Recommendation ITU-R F.592	Vocabulary of terms for the fixed service
Recommendation ITU-R F.595	Radio-frequency channel arrangements for fixed wireless systems operating in the 17.7-19.7 GHz frequency band
Recommendation ITU-R F.635	Radio-frequency channel arrangements based on a homogeneous pattern for fixed wireless systems operating in the 4 GHz (3 400-4 200 MHz) band
Recommendation ITU-R F.636	Radio-frequency channel arrangements for fixed wireless systems operating in the 14.4-15.35 GHz band
Recommendation ITU-R F.637	Radio-frequency channel arrangements for fixed wireless systems operating in the 21.2-23.6 GHz band
Recommendation ITU-R P.676	Attenuation by atmospheric gases
Recommendation ITU-R F.701	Radio-frequency channel arrangements for digital point-to-multipoint radio systems operating in frequency bands in the range 1 350 to 2 690 MHz (1.5, 1.8, 2.0, 2.2, 2.4 and 2.6 GHz)
Recommendation ITU-R F.746	Radio-frequency arrangements for fixed service systems
Recommendation ITU-R F.747	Radio-frequency channel arrangements for fixed wireless system operating in the 10.0-10.68 GHz band
Recommendation ITU-R F.748	Radio-frequency arrangements for systems of the fixed service operating in the 25, 26 and 28 GHz bands
Recommendation ITU-R F.749	Radio-frequency arrangements for systems of the fixed service operating in sub-bands in the 36-40.5 GHz band
Recommendation ITU-R F.758	System parameters and considerations in the development of criteria for sharing or compatibility between digital fixed wireless systems in the fixed service and systems in other services and other sources of interference
Recommendation ITU-R P.833	Attenuation in vegetation
Recommendation ITU-R P.837	Characteristics of precipitation for propagation modelling
Recommendation ITU-R P.838	Specific attenuation model for rain for use in prediction methods
Recommendation ITU-R P.840	Attenuation due to clouds and fog
Recommendation ITU-R F.1098	Radio-frequency channel arrangements for fixed wireless systems in the 1 900-2 300 MHz band
Recommendation ITU-R F.1099	Radio-frequency channel arrangements for high- and medium-capacity digital fixed wireless systems in the upper 4 GHz (4 400-5 000 MHz) band
Recommendation ITU-R F.1101	Characteristics of digital fixed wireless systems below about 17 GHz



Recommendation ITU-R F.1105	Fixed wireless systems for disaster mitigation and relief operations
Recommendation ITU-R P.1238	Propagation data and prediction methods for the planning of indoor radiocommunication systems and radio local area networks in the frequency range 300 MHz to 450 GHz
Recommendation ITU-R F.1242	Radio-frequency channel arrangements for digital radio systems operating in the range 1 350 MHz to 1 530 MHz
Recommendation ITU-R F.1243	Radio-frequency channel arrangements for digital radio systems operating in the range 2 290-2 670 MHz
Recommendation ITU-R F.1399	Vocabulary of terms for wireless access
Recommendation ITU-R F.1496	Radio-frequency channel arrangements for fixed wireless systems operating in the band 51.4-52.6 GHz
Recommendation ITU-R F.1497	Radio-frequency channel arrangements for fixed wireless systems operating in the band 55.78-66 GHz
Recommendation ITU-R F.1498	Deployment characteristics of fixed service systems in the band 37-40 GHz for use in sharing studies
Recommendation ITU-R F.1520	Radio-frequency arrangements for systems in the fixed service operating in the band 31.8-33.4 GHz
Recommendation ITU-R F.1567	Radio-frequency channel arrangement for digital fixed wireless systems operating in the frequency band 406.1-450 MHz
Recommendation ITU-R F.1568	Radio-frequency block arrangements for fixed wireless access systems in the range 10.15-10.3/10.5-10.65 GHz
Recommendation ITU-R F.1777	System characteristics of television outside broadcast, electronic news gathering and electronic field production in the fixed service for use in sharing studies
Recommendation ITU-R BT.1872	User requirements for digital electronic news gathering
Recommendation ITU-R P.2001	A general purpose wide-range terrestrial propagation model in the frequency range from 30 MHz to 50 GHz
Recommendation ITU-R M.2003	Multiple gigabit wireless systems in frequencies around 60 GHz
Recommendation ITU-R F.2004	Radio-frequency channel arrangements for fixed service systems operating in the 92-95 GHz range
Recommendation ITU-R F.2005	Radio-frequency channel and block arrangements for fixed wireless systems operating in the 42 GHz (40.5 to 43.5 GHz) band
Recommendation ITU-R F.2006	Radio-frequency channel and block arrangements for fixed wireless systems operating in the 71-76 and 81-86 GHz bands
Recommendation ITU-R BT.2020	Parameter values for ultra-high definition television systems for production and international programme exchange
Recommendation ITU-R M.2083	IMT Vision – Framework and overall objectives of the future development of IMT for 2020 and beyond
Recommendation ITU-R F.2086	Deployment scenarios for point-to-point systems in the fixed service
Report ITU-R BT.2069	Tuning ranges and operational characteristics of terrestrial electronic news gathering (ENG), television outside broadcast (TVOB) and electronic field production (EFP) systems
Report ITU-R F.2086	Technical and operational characteristics and applications of broadband wireless access in the fixed service

Report ITU-R F.2107	Characteristics and applications of fixed wireless systems operating in frequency ranges between 57 GHz and 134 GHz
Report ITU-R M.2243	Assessment of the global mobile broadband deployments and forecasts for International Mobile Telecommunications
Report ITU-R M.2334	Passive and active antenna systems for base stations of IMT systems
Report ITU-R BT.2344	Information on technical parameters, operational characteristics and deployment scenarios of SAB/SAP as utilized in broadcasting
Report ITU-R M.2376	Technical feasibility of IMT in bands above 6 GHz
Report ITU-R F.2393	Use of fixed service for transport of traffic, including backhaul, for IMT and other terrestrial mobile broadband systems
Report ITU-R M.2410	Minimum requirements related to technical performance for IMT-2020 radio interface(s)
Report ITU-R F.2416	Technical and operational characteristics and applications of the point-to-point fixed service applications operating in the frequency band 275-450 GHz

### Other related documents

ARIB STD-B43:	Portable Millimetre-Wave Digital Transmission System for Television Program Contribution
ECC Recommendation (09)01:	Use of the 57-64 GHz frequency band for point-to-point fixed wireless systems
ECC Report 114:	Compatibility studies between Multiple Gigabit Wireless Systems in frequency range 57-66 GHz and other services and systems (except ITS in 63-64 GHz)
ECC Report 173:	Fixed service in Europe, Current use and future trends post 2011
ETSI TR 102 311:	Fixed Radio Systems; Point-to-point equipment; Specific aspects of the spatial frequency reuse method using Multiple Antenna Techniques (MIMO) ( <a href="http://www.etsi.org/standards-search">http://www.etsi.org/standards-search</a> (this is the page for typing the number of the TR 102 311))

---