

International Telecommunication Union

ITU-R
Radiocommunication Sector of ITU

Report ITU-R F.2086-1
(11/2010)

**Technical and operational characteristics
and applications of broadband wireless
access in the fixed service**

F Series
Fixed service



International
Telecommunication
Union

Foreword

The role of the Radiocommunication Sector is to ensure the rational, equitable, efficient and economical use of the radio-frequency spectrum by all radiocommunication services, including satellite services, and carry out studies without limit of frequency range on the basis of which Recommendations are adopted.

The regulatory and policy functions of the Radiocommunication Sector are performed by World and Regional Radiocommunication Conferences and Radiocommunication Assemblies supported by Study Groups.

Policy on Intellectual Property Right (IPR)

ITU-R policy on IPR is described in the Common Patent Policy for ITU-T/ITU-R/ISO/IEC referenced in Annex 1 of Resolution ITU-R 1. Forms to be used for the submission of patent statements and licensing declarations by patent holders are available from <http://www.itu.int/ITU-R/go/patents/en> where the Guidelines for Implementation of the Common Patent Policy for ITU-T/ITU-R/ISO/IEC and the ITU-R patent information database can also be found.

Series of ITU-R Reports

(Also available online at <http://www.itu.int/publ/R-REP/en>)

Series	Title
BO	Satellite delivery
BR	Recording for production, archival and play-out; film for television
BS	Broadcasting service (sound)
BT	Broadcasting service (television)
F	Fixed service
M	Mobile, radiodetermination, amateur and related satellite services
P	Radiowave propagation
RA	Radio astronomy
RS	Remote sensing systems
S	Fixed-satellite service
SA	Space applications and meteorology
SF	Frequency sharing and coordination between fixed-satellite and fixed service systems
SM	Spectrum management

Note: This ITU-R Report was approved in English by the Study Group under the procedure detailed in Resolution ITU-R 1.

Electronic Publication
Geneva, 2011

© ITU 2011

All rights reserved. No part of this publication may be reproduced, by any means whatsoever, without written permission of ITU.

REPORT ITU-R F.2086-1

**Technical and operational characteristics and applications
of broadband wireless access in the fixed service**

(2006-2010)

TABLE OF CONTENTS

	<i>Page</i>
1 Introduction	2
2 Scope	3
3 References	3
4 List of acronyms and abbreviations.....	4
5 Application and services.....	5
6 Characteristics	6
6.1 Operating frequency ranges.....	6
6.2 Spectrum utilization efficiency.....	7
6.3 Topology structures	8
6.3.1 P-P deployment topology.....	8
6.3.2 P-MP deployment topology	8
6.3.3 MP-MP deployment topology.....	9
6.3.4 Combination P-P, P-MP and MP-MP deployment topology.....	9
6.4 Antennas	10
6.5 Duplexing	10
6.6 Types of deployment	11
6.6.1 Line-of-sight operation	11
6.6.2 Non-line-of-sight operation.....	11
6.6.3 Planar deployment.....	11
6.6.4 Spot deployment	14
6.6.5 Backhaul deployment.....	14
6.6.6 Combination deployment.....	14
6.7 Transport characteristics.....	14
6.7.1 Service independence.....	14
6.7.2 Service support.....	14
6.7.3 Flexible asymmetry.....	15
6.7.4 Per-subscriber rate adaptation.....	16
6.7.5 Throughput.....	16

	<i>Page</i>
6.7.6 Scalability.....	16
6.7.7 Radio specific security	16
6.8 System management function.....	16
6.9 Interference mitigation.....	16
6.9.1 Interference types.....	16
6.9.2 Interference mitigation techniques.....	17
6.9.3 Application of interference mitigation techniques.....	18
6.10 Technical characteristics of BWA providing high quality service applications.	18
6.11 New technologies system support	19
Annex 1 – Example of one specific BWA application	21
1 Introduction	21
2 Service outline and system configuration.....	21
3 Basic system parameters.....	23
4 Fixed BWA connections.....	23
4.1 Connection between APs in the train.....	23
4.2 Backhaul links between the intermediate stations	24
5 Connection to a WAN	24
Annex 2 – Example of integrated BWA application in rural area	24
1 Introduction	24
2 System configuration.....	24
3 Basic system parameters.....	26
4 Feasibility test.....	26
Annex 3 – Example of BWA system providing high quality service applications.....	26
1 Introduction	26
2 Service images.....	27
3 Main specifications and comparison to conventional BWA	28

1 Introduction

This Report provides characteristics and applications of broadband wireless access (BWA) systems in the fixed service for use by administrations and operators intending to deploy BWA systems. BWA systems including fixed service applications of RLANs are being widely used for transportable, nomadic and fixed equipment and for a variety of services. There are standards that address the interoperability and operation of these systems. Radio interface standards for fixed BWA systems are provided in Recommendations ITU-R F.1763 and ITU-R F.1499, which specify detailed interfaces for the interoperability of radio equipment operating below 66 GHz.

2 Scope

This Report summarizes generic technical and operational characteristics needed to provide BWA systems in the fixed service including RLANS to end users. It includes technical consideration on the frequency range as well as radio propagation characteristics related to the deployment of BWA. Information on technical and operational requirements related to interference avoidance is also given.

3 References

- [1] Recommendation ITU-R F.1490 – Generic requirements for fixed wireless access systems.
- [2] ETSI TR 101 856 V1.1.1 (2001-03), Broadband Radio Access Networks (BRAN) – “Functional Requirements for Fixed Wireless Access systems below 11 GHz: HIPERMAN.
- [3] IEEE 802.16.3-00/02r4, 22.09.2000, – Functional Requirements for the 802.16.3 Interoperability Standard.
- [4] Recommendation ITU-R F.1704 – Characteristics of multipoint-to-multipoint fixed wireless systems with mesh network topology operating in frequency bands above about 17 GHz.
- [5] Recommendation ITU-R F.1401 – Considerations for the identification of possible frequency bands for fixed wireless access and related sharing studies.
- [6] Recommendation ITU-R F.755 – Point-to-multipoint systems in the fixed service.
- [7] Recommendation ITU-R F.1400 – Performance and availability requirements and objectives for fixed wireless access to public switched telephone network.
- [8] Recommendation ITU-R M.1450 – Characteristics of broadband radio local area networks.
- [9] Recommendation ITU-R F.1763 – Radio interface standards for broadband wireless access systems in the fixed service operating below 66 GHz.
- [10] Recommendation ITU-R F.1399 – Vocabulary of terms for wireless access.
- [11] Recommendation ITU-R F.1499 – Radio transmission systems for fixed broadband wireless access based on cable modem standards.
- [12] Recommendation ITU-R SM.1046 – Definition of spectrum use and efficiency of a radio system.
- [13] ETSI TS 101 999 V1.1.1 (2002-04) – Broadband Radio Access Networks (BRAN); HiperACCESS; PHY (Physical Layer) protocol specification.
- [14] ETSI TS 102 000 V1.4.1 (2004-07) – Broadband Radio Access Networks (BRAN); HiperACCESS; DLC (Data Link control) protocol specification.
- [15] Draft ETSI EN 302 326 (V0.0.8 2004-10) – Fixed Radio Systems; Multipoint equipment and antennas.
- [16] ARIB STANDARD STD-T59 – Fixed Wireless Access System using quasi-millimeter-wave and millimeter-wave band frequencies, Point-to-multipoint System (http://www.arib.or.jp/english/html/overview/st_e.html).
- [17] Report ITU-R F.2060 – Fixed service use in the IMT-2000 transport network.
- [18] Recommendation ITU-R F.746 – Radio-frequency arrangements for fixed service systems.
- [19] Report ITU-R F.2058 – Design techniques applicable to broadband fixed wireless access systems conveying Internet Protocol packets or asynchronous transfer mode cells;
- [20] Report ITU-R F.2047 – Technology developments and application trends in the fixed service.
- [21] ITU-R Handbook on Fixed Wireless Access: (Volume 1 of the Land Mobile (including Wireless Access)).

4 List of acronyms and abbreviations

AP	Access point
APS	Antenna pattern shaping
ARIB	Association of Radio Industries and Businesses
ATM	Asynchronous transfer mode
BEM	Block edge mask
BER	Bit error ratio
BRAN	Broadband radio access network (ETSI)
BS	Base station
BWA	Broadband wireless access
CDMA	Code division multiple access
<i>C/I</i>	Carrier-to-interference
Diffserv	Differentiated services
DL	Downlink
DLC	Data link control
ETSI	European Telecommunications Standards Institute
FDD	Frequency division duplex
FSK	Frequency shift keying
FWA	Fixed wireless access
GPS	Global positioning system
HDTV	High definition television
H-FDD	Half duplex FDD
HIPERMAN	High performance radio metropolitan area network
HQSA	High quality service application
IEEE	Institute of Electrical and Electronics Engineering
ISI	Inter-symbol-interference
IP	Internet protocol
ISP	Internet service providers
LAN	Local area network
LoS	Line-of-sight
MA	Multiple access
MAN	Metropolitan area network
MIMO	Multiple input multiple output
MPEG4	Moving Picture Experts Group 4
MP-MP	Multipoint-to-multipoint
MPLS	Multi-protocol label switching
MUD	Multi-user detection
NLOS	Non-line-of-sight
OFDM	Orthogonal frequency division multiplex
OFDMA	Orthogonal frequency-division multiple access

PoI	Points of interface
POTs	Plain ordinary telephone service
P-P	Point-to-point
P-MP	Point-to-multipoint
QAM	Quadrature amplitude modulation
QoS	Quality of service
RLAN	Radio local area network
RSVP	Resource reservation protocol
SDH	Synchronous digital hierarchy
SLA	Service level agreement
SME	Small medium enterprise
SINR	Signal and interference to noise ratio
SNMP	Simple network management protocol
SOHO	Small office home office
ST	Subscriber terminal
SU	Subscriber unit
TCP/IP	Transmission control protocol/Internet protocol
TDD	Time division duplex
UL	Uplink
VoIP	Voice over Internet protocol
WAN	Wide area network
WAS	Wireless access systems

5 Application and services

BWA systems operating in the fixed service should support a wide range of applications in use today and be extendable to support future services. The main user applications that can be foreseen today are as follows:

- Internet access (e.g. IP versions 4 and 6)
- LAN bridging and remote LAN access
The protocols could support bridged LAN service and remote LAN access capabilities.
- videotelephony and videoconferencing
- computer gaming
- real-time video and audio
- telemedicine; tele-education
- telephony/voice services (e.g. VoIP)
- voice-band modems and fax

The system could facilitate unicast, multicast, as well as broadcast services.

Fixed BWA systems can also be used to provide backhaul links for local area networks (LAN), metropolitan area networks (MAN), and cellular mobile networks, as well as synchronous digital hierarchy (SDH) rings.

6 Characteristics

The following items present some characteristics to deploy BWA systems in the fixed service. The frequency bands to be used may vary in each country; proper band plan and equipment availability should be considered to provide reuse of frequency and proper scale for the equipments production.

Other characteristics should be considered on deployment of BWA systems, specially to encourage efficient spectrum usage, the quality of service (QoS) provided and the use of new technologies.

6.1 Operating frequency ranges

Fixed BWA systems should be operated in a wide frequency range to conform with a variety of bands available in each country. Recommendation ITU-R F.1401 may be used as guidance for consideration of the identification of possible frequency bands for BWA and related sharing studies.

Table 1 provides additional details regarding the frequency bands used in some administrations for wireless access systems (WAS), including BWA and RLANs. A variety of modulation and multiple access techniques can be used by BWA systems.

TABLE 1
Example frequency ranges used in some administrations for WAS,
including BWA and RLANs*

Frequency	Frequency ranges/bands
UHF (300-3 000 MHz)	800/900 MHz 902-928 MHz 1 800/1 900 MHz 2 400-2 483.5 MHz
SHF (3-30 GHz)	3.3-3.9 GHz 4.9-5.0 GHz 5.150-5.250 GHz 5.250-5.350 GHz 5.470-5.725 GHz 5.725-5.850 GHz 18 GHz 24/25/28/29 GHz
EHF (30-300 GHz)	32 GHz 38 GHz 40 GHz

* These bands are not necessarily allocated by Article 5 in the Radio Regulations (RR) to the fixed service, and may involve, for example, fixed applications in the mobile service.

Each BWA system is typically designed to utilize specific channel spacing(s) and channel bandwidth(s) depending on standards utilized or individual manufacturer designs. Different BWA systems, however, can be designed with different channel spacings and for deployments with various base station sectorizations to support efficient use of the spectrum within the available licensed frequency bands or blocks.

For radio-frequency arrangements for fixed wireless access (FWA) including BWA systems, other ITU-R Recommendations (e.g. Recommendation ITU-R F.746) may also be used as guidance.

6.2 Spectrum utilization efficiency

Information on spectrum utilization efficiency (SUE), including general criteria for evaluation and comparison of spectrum efficiencies can be found in Recommendation ITU-R SM.1046. Studies undertaken by Radiocommunication Study Group (SG) 1 and mentioned in Recommendation ITU-R SM.1046 indicate that SUE should be measured in terms of ratio of the amount of information transferred over a distance to the spectrum utilization factor. Factors that determine the efficient use of spectrum include the isolation obtained from antenna directivity, geographical spacing, frequency sharing, or orthogonal frequency use and time-sharing or time division.

One of the factors which decide the occupied bandwidth¹ is the characteristics of spectrum shaping/filtering. The equipment should be able to efficiently use the spectrum, with almost no degradation in capacity when co-locating access points and using adjacent channels.

To achieve the above, when different operators are assigned to use adjacent channels or adjacent blocks, a certain guardband from the boundary frequency is required. Such an approach has the effect of regulating the carrier separation BW that can be used in each licensed band and requiring that they are the same for all licensed bands.

An example of the required carrier separation from the boundary frequency for P-MP systems are as follows. In Fig. 1, the centre frequency of the transmitted carriers should have the required separation in frequency BW from the boundary of the adjacent frequency block, which is assigned to a different operator.

For this example, BW is defined as below:

$$BW = 1.25 \times BW_0$$

where BW_0 is the nearest frequency from the centre, at which the relative level of the measured spectrum becomes -23 dB lower than the maximum spectrum level.

In principle, the operator should use, within their assigned block, the radio channels closer to the frequency block centre with higher priority. In multicarrier systems, the above requirements should apply to the most outer carrier from the frequency block centre.

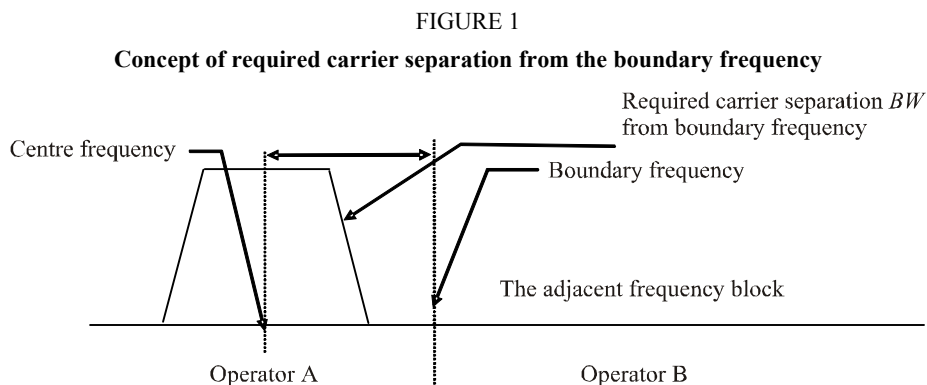

Rep 2086-01

¹ The width of a frequency band such that, below the lower and above the upper frequency limits, the mean powers emitted are each equal to a specified percentage $\beta/2$ of the total mean power of a given emission (defined in RR 1.153).

Another approach, known as the block edge mask (BEM) approach, is also used for the assignment of adjacent spectrum blocks to operators in the same geographical area. Contiguous blocks are assigned without guardband, and equipment has to fulfil the provisions of the BEM. This approach allows operators to deploy systems with any carrier separation BW, including different carrier separation BWs in adjacent blocks, so long as their emissions at the block edge are below the BEM.

6.3 Topology structures

There are four kinds of basic topology:

- a conventional point-to-point (P-P) topology where a station communicates directly with another station;
- a conventional point-to-multipoint (P-MP) topology where each subscriber unit (SU) communicates directly with a base station (BS);
- a multipoint-to-multipoint (MP-MP) with mesh network topology where SUs communicate with nearest neighbours and information is passed back through the mesh in a manner analogous to internet traffic;
- a combination of P-P, P-MP and MP-MP topology.

The main difference between the P-MP and MP-MP topology structures is that in the P-MP mode, traffic only occurs between BS and SUs while in the MP-MP topology traffic can occur directly between SUs and also can be routed further through other SUs. It should be noted that a P-P application may be used as an element link of P-MP or MP-MP topology, and that some backhaul links including mobile infrastructure may also use P-P application.

The above four topology structures, P-P, P-MP and MP-MP, or a combination structure of them, should be evaluated when being considered for implementation.

6.3.1 P-P deployment topology

In P-P systems, traffic is transmitted directly from one station to another. Uses for P-P systems also include backhaul links for LAN, MAN, and cellular mobile networks.

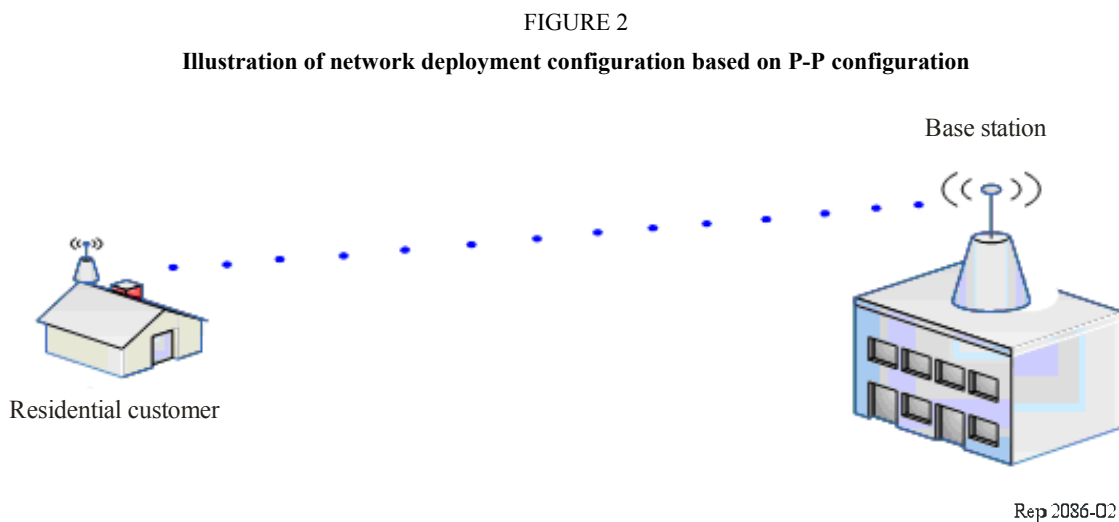

6.3.2 P-MP deployment topology

In P-MP systems, all data traffic (data, voice or multimedia) should go through the BS that shall serve as a radio resource supervisor.

Figure 3 shows an example deployment configuration. The BS can serve individual buildings, multiple subscribers in multiple buildings (using multiple radio links), or multiple subscribers in a single building by use of a single radio link and further in-building distribution systems. It shows the use of an optional repeater and route diversity in order to provide extended coverage and coverage in difficult areas. This does not imply the use of these features in all systems.

BWA base stations are deployed to form either contiguous cells or spot-type coverage.

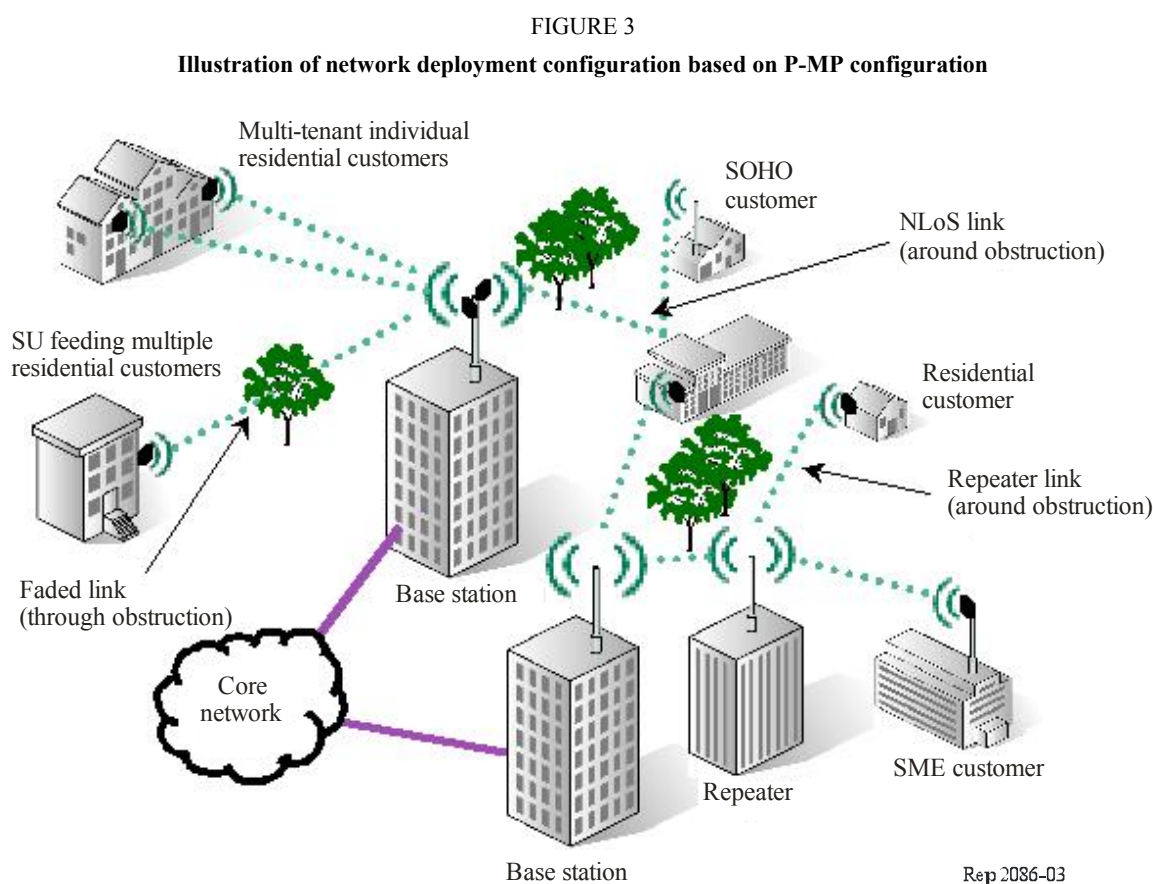

6.3.3 MP-MP deployment topology

The system may support MP-MP with mesh network topology.

Figure 4 illustrates an example of MP-MP system with mesh network topology. The wireless mesh network consists of wireless nodes, which are either customer sites, relay nodes without originating/terminating traffic, or points of interface (PoI) to other networks such as ISP networks. The entire network shown in Fig. 4 can be regarded as an MP-MP system. When at least one diversity route is available in the network, the system is specifically referred to as “an MP-MP system with mesh network topology” (see Recommendation ITU-R F.1704).

6.3.4 Combination P-P, P-MP and MP-MP deployment topology

Figure 5 illustrates an example of mix topology. In this case, the wireless network may have both P-MP and MP-MP links and the BS supporting its SU may be connected to the other networks via backbone network.

FIGURE 4

Illustration of network deployment configuration based on MP-MP configuration

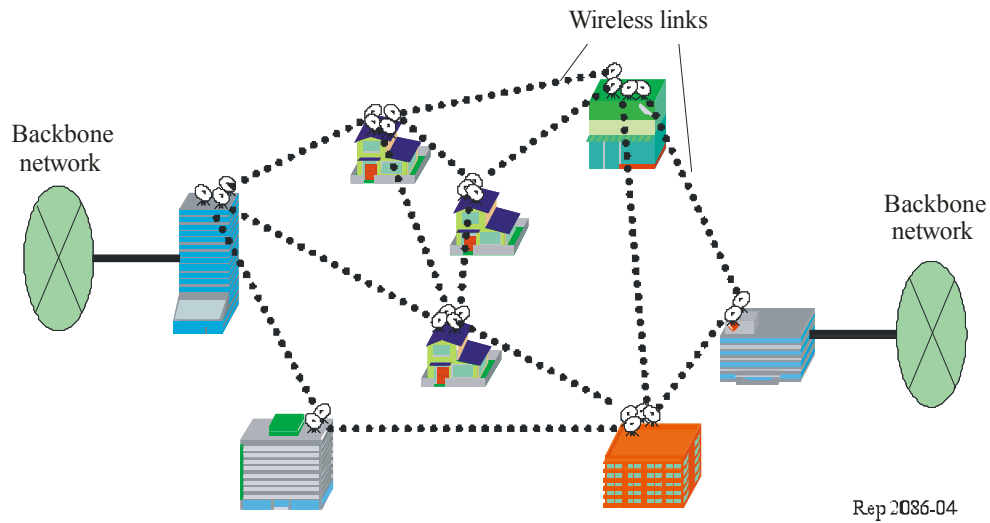
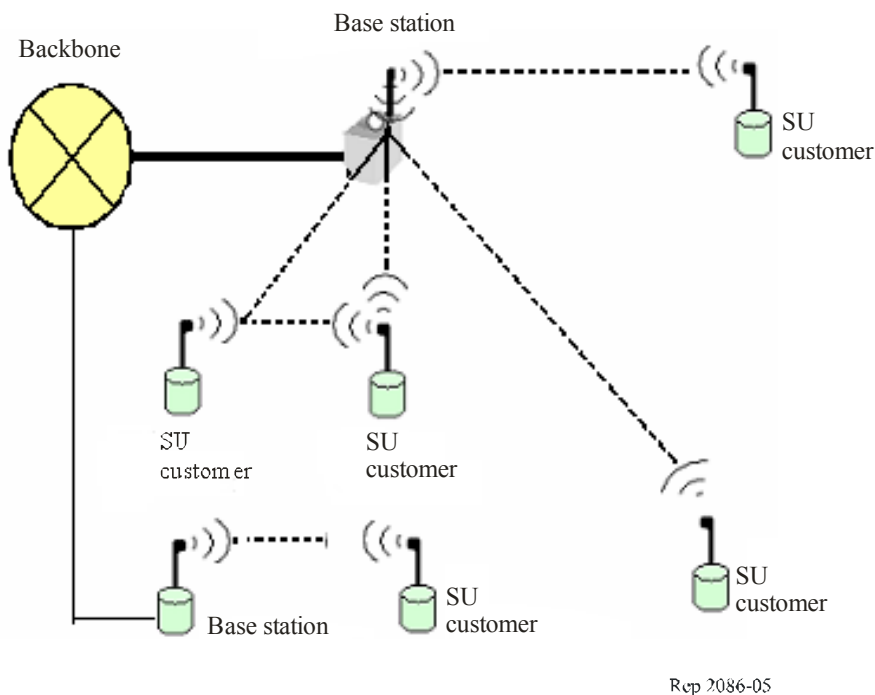

FIGURE 5

Illustration of network deployment based on combination P-P, P-MP and MP-MP configuration



6.4 Antennas

Antenna performance is specified in a variety of ways. For interference considerations, while general side-lobe suppression is important, the front-to-back ratio is one of the most important parameters in a cellular topology. The front-to-back ratio of an antenna indicates the ratio of the gain in the antenna main beam direction to that in the opposite direction (see § 6.9.2.2).

6.5 Duplexing

BWA in the fixed service may be implemented with either FDD or TDD operation or their combination.

In FDD mode, the base station should support full-duplex FDD. SU can choose to work in full-duplex FDD or half-duplex FDD (H-FDD) mode. For supporting SUs work in H-FDD mode, the BS must ensure that it does not schedule an H-FDD SU to transmit and receive at the same time.

In TDD mode the system may support dynamic variable duration for the uplink (UL) and the downlink (DL), according to the existing asymmetric traffic, and with the required synchronization in the area where the TDD systems are being used to make it possible to support more than one system.

The duplexing scheme should be selected in conjunction with the preferred modulation as well as multiple access (MA) techniques. There are several combinations of MA/modulation techniques that have been established as BWA standards, which are found in the following ITU-R texts:

- Report ITU-R F.2058 – Design techniques applicable to broadband fixed wireless access systems conveying Internet protocol packets or asynchronous transfer mode cells;
- Recommendation ITU-R M.1450 – Characteristics of broadband radio local area networks, (for BWA systems based on FS applications of RLANS).

6.6 Types of deployment

6.6.1 Line-of-sight operation

The BWA system should be able to operate in line-of-sight (LoS) conditions with different polarization regardless of the operating frequency band.

6.6.2 Non-line-of-sight operation

Non-line-of-sight (NLoS) operation capability can ease or eliminate antenna installation requirements, and enable user installable terminals that can significantly cut the deployment cost.

The BWA system, when it is operated in the lower frequency bands, e.g. below 6 GHz, may be able to operate in NLoS conditions. Due to the multipath inherent in the targeted frequency bands, such a BWA system may be capable of handling several μ s of delay spread with limited performance degradation.

The NLoS operation requires resistance to multipath and increased system gain. BWA systems supporting such operation typically provides means for increasing the UL budget, without affecting the subscriber terminal (ST) complexity.

6.6.3 Planar deployment

Planar deployments are chosen when service providers decide that they want to deliver ubiquitous BWA service to a large area. The benefit of a planar deployment lies in the fact that all of the area will be covered uniformly. The downside lies in the increase in up-front planning and design required.

Guidance on design techniques for planar deployments is available in ITU Handbooks such as the Fixed Wireless Access Handbook and other publications outside the ITU. Specific examples follow.

Figure 6 shows examples of frequency planning in a planar deployment. In order to avoid interference, the frequencies used in each cell must follow strict deployment guidelines. Frequency reuse patterns are decided considering required C/I ratio and available frequency channels. In Fig. 6a), depicting a typical hexagon cell planar deployment, there are seven channels being used in the entire network. Figure 6b) depicts a typical six sector per access point (AP) cellular deployment where only three channels are being used in the entire network. In this deployment scenario, the cluster of access points is synchronized to ensure that they transmit and receive in the proper cycles so that the frequencies can be re-used in the depicted manner.

FIGURE 6

Examples of frequency planning in a planar deployment

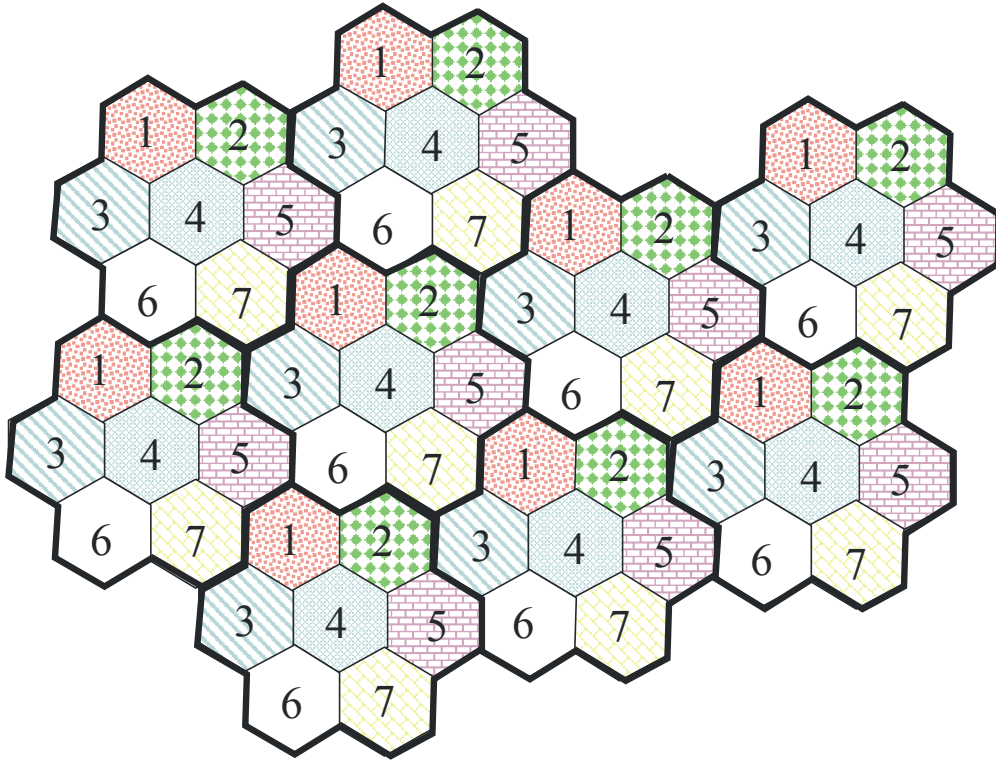

a) Hexagon cell planar deployment

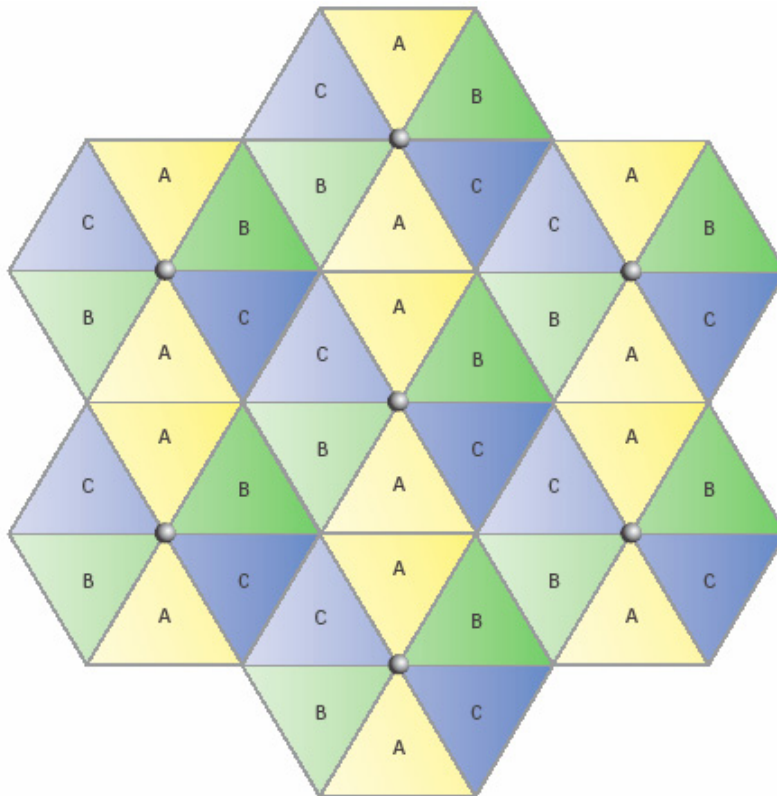

b) Six sector triangle cell planar deployment

For systems with less robust modulation schemes, the *C/I* ratio requirements often drive frequency reuse patterns. This is because before a given frequency channel can be used again at a second cell site, it has to be far enough away to satisfy the *C/I* ratio requirement.

The range of a given system with a clear LoS path can be calculated as follows. First determine the “link budget” available, then compare to the charts below. Tables 2 and 3 are examples of link budgets for operation in the 2.4 GHz and the 5.8 GHz band, respectively. Note the return path is typically the limiting factor and it is suggested that this be used for determining the range.

- Link budget (dB) = Tx power (dBm)
- + Transmitting antenna gain (dBi)
 - + Receive antenna gain (dBi)
 - Receive Sensitivity (–xxdBm)
 - Antenna cable losses
 - RF fade margin
 - Interference margin

TABLE 2

An example of 2.4 GHz link budget

Link budget (dB)	100	103	106	109	112	115	118	121	124	127	130
Distance (km)	1	1.5	2	3	4	6	8	11	16	23	32

TABLE 3

An example of 5.8 GHz link budget

Link budget (dB)	101	104	107	110	113	116	119	122	125	128	131	134	137	139
Distance (km)	0.4	0.6	0.8	1	1.7	2.5	3.5	5	7	10	14	20	27	32

The net effect for a planar deployment with a system using higher order modulations typically means more channels are required in order to satisfy the *C/I* ratio.

6.6.3.1 Synchronization

When deploying a TDD system in a planar topology, it is desirable to be able to use the same frequency in each cell site even though those cell sites are possibly several miles away. As such, co-channel interference can occur between same channel sectors of adjacent base stations. In this case, inter-cellular synchronization is required, making sure that all the sectors in all the cell sites are properly timed and synchronized in terms of downstream and upstream communications.

Delivering tight synchronization across potentially hundreds of square miles can be a challenge. With a system, designed for large scale, dense network deployments, TDD synchronization is a critical requirement. This has been solved with the use of a GPS signal. These precise satellite signals are used for timing and, ultimately, transmit/receive synchronization, thus tying all sectors in a network to the same “clock”. It should be noted that this synchronization only applies to digital modulation systems.

6.6.4 Spot deployment

Many BWA deployments start out being installed in what is referred to as a “spot deployment” model. This topology refers to a single cell site, or possibly several, that are not geographically contiguous but are chosen to serve specific areas of need. This is contrasted with a planar deployment approach in which the goal is to provide BWA coverage across an entire region and hence the cell sites are deployed such that there are no LoS gaps in coverage.

When a fixed BWA system is deployed in a spot method, assuming that each “spot” is sufficiently distant from the other “spots”, frequency coordination and planning are not usually an issue for intra-system interference, and each cell site is installed with what is best for that area of coverage alone as a deployment guide.

6.6.5 Backhaul deployment

In many cases, P-MP networks are located in areas where the wired infrastructure is not well developed. The location of the cell site is chosen based on where potential customers are located, where a high tower or building can be used, etc.

When the base station is located where there is no significant copper or fibre connection into the core network, they need to have also a P-P solution to provide backhaul link for the backhaul connection for the BWA system to be effective. Additionally, an attractive application for BWA systems is that they can be used to provide backhaul connectivity for other radio LAN systems operating within the coverage area of the BWA system.

6.6.6 Combination deployment

Fixed BWA systems are often deployed in combination with other kinds of BWA, i.e. mobile and nomadic, providing integrated BWA services. Such applications are particularly useful in the environments where cable infrastructure is not yet deployed.

If the design of the radio equipments in the BWA are based on the interoperable specifications such as those referred to in Recommendation ITU-R F.1763, the entire cost for wireless facilities may reasonably be reduced. Specific examples of converged BWA applications are described in Annexes 1 and 2.

6.7 Transport characteristics

6.7.1 Service independence

A fixed BWA system should provide services without requiring information on the type of application.

6.7.2 Service support

6.7.2.1 QoS

The system should support QoS guarantees to provide the transported services. Thus, the protocol standards should define interfaces and procedures that accommodate the requirements of the services with respect to allocation of prioritization of radio resources. Current applications and their relationships are shown in Fig. 7.

FIGURE 7
Some currently available applications and their typical bandwidth and QoS requirements

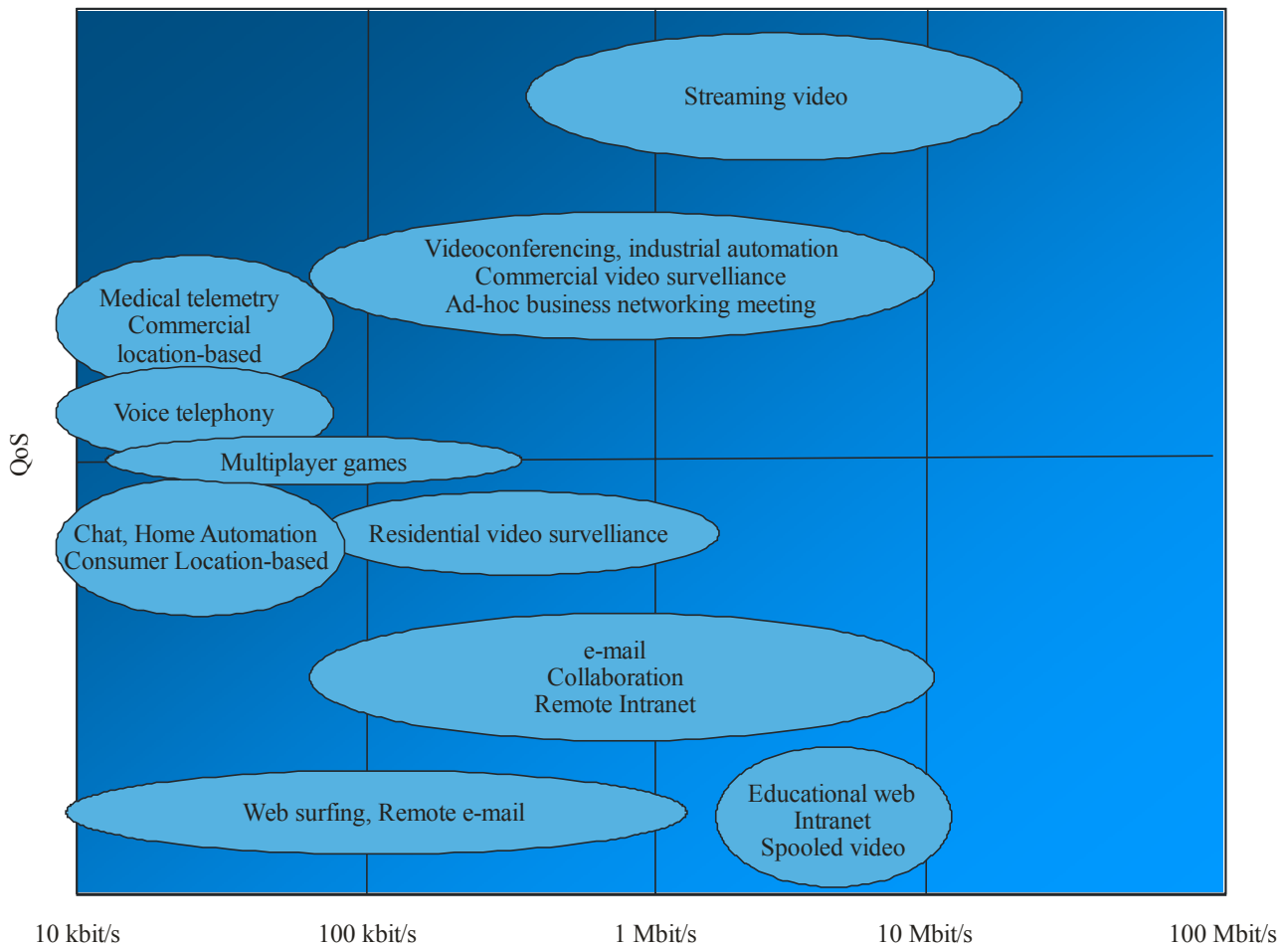

Rep 2086-07

6.7.2.2 Application QoS mappings

The basic mechanism available within the systems for supporting QoS/service class requirements should be able to allocate various bandwidths to various applications. Some protocols include a mechanism that supports dynamically variable bandwidth channels and paths (such as those defined for IP environments).

Since customer units will contend for capacity to/from one or more base stations, contention and bandwidth allocation should be efficiently resolved.

6.7.3 Flexible asymmetry

Over a short period of time (e.g. a few seconds) the traffic generated by and for any given user can be highly asymmetric in either way. Some BWA systems efficiently support this type of asymmetric traffic. Over longer periods of time, a given user can need on average more bandwidth in one way than in the reverse way.

The total traffic generated by and for all the users sharing the same radio resource may be instantaneously asymmetric or even asymmetric during a long period of time, depending on the type of users connected to the shared resource.

6.7.4 Per-subscriber rate adaptation

Different modulation and/or coding options for far and near subscriber stations may be applied. In this way the data rate to/from relatively near subscribers can be higher, increasing the overall system capacity. Additionally, far subscribers can experience different interference profiles and so would benefit from rate adaptation. Most BWA systems provide for multirate support.

It is desirable to accommodate channel capacity issues and changes in channel capacity to meet contracted service levels with customers. For example, flexible modulation types, power level adjustment, and bandwidth reservation schemes are typically employed.

6.7.5 Throughput

Although throughput depends on bandwidth, modulation scheme etc., to be competitive with wired solutions, it is desirable for the system to support a data rate at the access point of more than several 10 Mbit/s, which is the instantaneous aggregated bit rate (up plus downstream), and shared among the users.

6.7.6 Scalability

Scalability protocols allow for different capacities and performance for the system instances. BWA systems often support features to maximize the scalability of a deployment.

6.7.7 Radio specific security

BWA systems typically provide secure means of authentication, authorization and adequate means of encryption to ensure privacy.

6.8 System management function

The system should define a network management interface based on existing open standard protocols (for example SNMP), which enables the following management aspects:

- **Fault and performance management**

The protocols should enable fault and performance monitoring, as well as provide means for local and remote testing for each SU individually. The management functionality must include reboot, reactivation and shutdown capabilities.

- **Configuration and software upgrading management**

The protocols should enable both local and remote configuration including the updating of software in any device in the network without service interruption.

- **Security**

The system should enable centralized authentication and authorization services.

- **Service management**

The protocols should permit operators to enforce service level agreements (SLAs) with subscribers by restricting access to the air link, discarding data, dynamically controlling bandwidth available to a user or other appropriate means.

6.9 Interference mitigation

6.9.1 Interference types

The interference in a BWA system can be divided into intra-system interference and inter-system interference. And intra-system interference contains intra-cell interference and inter-cell interference.

6.9.2 Interference mitigation techniques

The following sections describe possible mitigation techniques that may be employed by BWA systems.

6.9.2.1 Site placement in network planning

Separating the interfering transmitters and the victim receivers can reduce the interference level at receivers.

6.9.2.2 Enhancing antenna performance

Improvements of antenna performance can reduce the interference to other directions, and decrease the interference to other cells. The following techniques can particularly enhance the performance of antennas:

- side-lobe suppressing
- front-to-back ratio improvement
- antenna pattern shaping (APS)

The combination of omnidirectional antenna for BS and narrow beam antenna for SU is suitable for P-MP systems to cover the entire service area efficiently. The antenna beam of SU is designed to be so narrow that most of the reflected signals are suppressed except for those coming from the reflectors such as buildings located near BS.

APS, using radio wave absorbent material, is a simple and economical solution for this type of interference. APS occurs when radio wave absorbent material is attached at antenna radome of BS so that signal strength toward reflectors is suppressed, consequently the strength of reflected signals incoming to SU are reduced.

The suppression angle is flexibly adjusted according to the reflector location.

An example of effect of this technique is presented in Fig. 8. Reflected signal exists at path length difference of 300 m without APS technique as shown in Fig. 8a). After adopting the APS technique, the reflected signal is suppressed below noise level as shown in Fig. 8b).

FIGURE 8

Example of an effect of APS technique

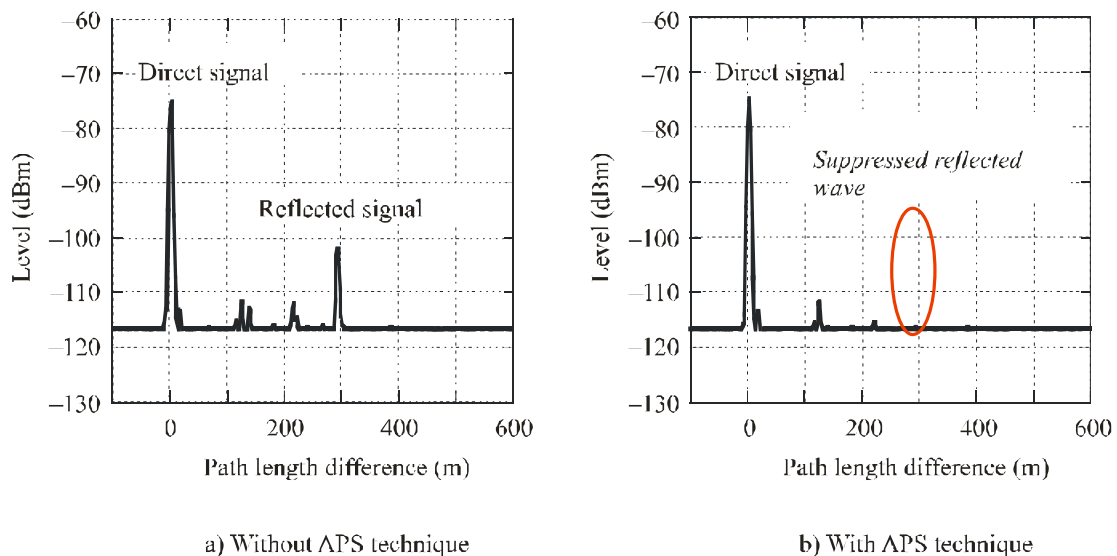

6.9.2.3 Power control

Transmit power is an important resource in BWA systems. For interference mitigation, the more important contribution of power control, especially automatic transmission power control (ATPC), is that it can avoid power wasting and decrease the interference level in the cell.

6.9.2.4 Multi-user detection (MUD) in a CDMA system

In a CDMA system, multi-user detection (MUD) techniques can effectively compress the inter-symbol-interference (ISI) and multiple access interference (MAI). One of the challenges for MUD is computation complexity.

6.9.2.5 Transmitter/receiver filtering improvements

Filtering improvements may reduce the unwanted signal out-band emissions from transmitter and reduce the in-band interference to the receiver.

6.9.2.6 Adaptive modulation and coding

Adaptive modulation and coding enable trade-offs between interference level and efficiency.

6.9.3 Application of interference mitigation techniques

TABLE 4

Application of interference mitigation techniques

Interference mitigation technique	Interference		
	Intra-cell	Inter-cell	Inter-system
Site placement		√	√
Enhancing antenna performance	√	√	√
Polarization isolation		√	
Synchronization	√	√	
Power control	√	√	√
MUD in CDMA system	√ ⁽¹⁾	√*	
Transmitter/receiver filtering improvements		√	√
Adaptive modulation and coding	√	√	√

⁽¹⁾ Only for CDMA system.

6.10 Technical characteristics of BWA providing high quality service applications

Broadband systems such as FTTH provide various kinds of high quality service applications (HQSAs), such as high-speed Internet access, multicast high definition television (HDTV) streaming and high-quality telephony/voice service. The conventional BWA system for mass-market can provide data transmission speed of about 40 Mbit/s at most and its service type is best effort without QoS control. Therefore, they cannot achieve the HQSAs.

Technical characteristics to achieve each HQSA are presented as follows:

1. High-speed Internet access

There are several grades of FTTH service providing different user interface data speed. The user interface data speed of Internet access data rate provided by the lowest grade of FTTH services is up to 100 Mbit/s. Internet access speed of higher than 100 Mbit/s is required to support QSAs provided by FTTH.

2. Multicast HDTV streaming

Multicast steaming and HDTV signal transmission is achieved by QoS control and multicast function.

3. High-quality telephony/voice service

The quality of IP telephone is influenced by parameters such as packet loss and delay, etc. QoS is required to achieve the quality of plain ordinary telephone service (POTS). Performance objectives for IP packet transmission are provided in ITU-T Recommendations Y.1540 and Y.1541. ITU-T Recommendation Y.1540 defines availability performance parameters, and Y.1541 specifies six QoS class and IP packet transfer performance parameters.

Example technical characteristics of the BWA system providing QSAs are described in Annex 3.

6.11 New technologies system support

The following technologies enhance the performance of BWA systems in the fixed service. Report ITU-R F.2047 provides further information on these and other technologies.

– Further improvement of spectral utilization efficiency

Advanced multi-state modulation scheme and/or MIMO technique enable to provide further broadband applications. Moreover, spectrum shaping and use of dual polarization also contribute to improve the spectral utilization efficiency.

– Convergence with other wireless and wired system

Broadband service is provided not only by FWA system, but also by other wireless system; satellite and mobile system. Furthermore, wired system also provides broadband service. Seamless service between these systems greatly improves user's convenience.

– Multifrequency band system

There are various conditions of propagation path, traffic, etc. Selection of the most appropriate frequency band system gives always best connection.

– Adaptive antenna systems

Adaptive antenna systems (AAS) refers to an array of antennas and associated signal processing that together is able to change its antenna radiation pattern dynamically to adjust to noise environment, interference and multipath. Adaptive arrays form an infinite number of patterns (scenario-based) that are adjusted in real-time. This means that while transmitting, the signal can be limited to the required direction of the receiver; like a spotlight. Conversely when receiving, the AAS can be made to focus only in the direction from where the desired signal is coming from. The advantage of using an adaptive antenna system is that it can reduce the effective interference within a cell by concentrating the energy between the base station and the active subscribers, and nulling out interference from other sources can therefore increase the cell capacity. They also have the property of suppressing co-channel interference from other locations. These properties enable the spectrum to be utilized in a more efficient manner.

– **Software defined radio**

A radio in which the RF operating parameters including but not limited to frequency range, modulation type, or output power can be set or altered by software, and/or the technique by which this is achieved.

NOTE 1 – Excludes changes to operating parameters which occur during the normal preinstalled and predetermined operation of a radio according to a system specification or standard.

NOTE 2 – Software defined radio (SDR) is an implementation technique applicable to many radio technologies and standards.

NOTE 3 – Within the mobile service, SDR techniques are applicable to both transmitters and receivers.

– **Adaptive modulation**

Adaptive modulation and coding technology makes the adaptation of a user's data rate as a function of the channel conditions (e.g. SINR, fading rate, etc.). The number of modulation levels is modified dynamically.

– **OFDM**

Orthogonal frequency division multiplexing (OFDM) is a multiplexing technique in which the channel bandwidth is subdivided into multiple subcarriers that are orthogonal to each other in frequency domain. The input data stream is then divided into multiple parallel substreams each with reduced data rate (thus increased symbol duration) and each substream is modulated and transmitted on a separate orthogonal subcarrier. OFDM technique distributes the data over a large number of carriers that are spaced apart at precise frequencies. This spacing provides the “orthogonality” in this technique which prevents the demodulators from seeing frequencies other than their own. Last samples of data portion of the data stream are typically appended as a repetition to the beginning of the data payload forming what is called a cyclic prefix (CP). CP can completely eliminate ISI as long as its duration is longer than the delay spread of the channel. OFDM exploits the frequency diversity of the multipath channel by coding and interleaving the information across the subcarriers prior to transmissions. OFDM modulation can be realized with inverse fast Fourier transform (IFFT), which enables a large number of subcarriers with low complexity. The benefits of OFDM are high spectral efficiency, resiliency to RF interference, improved robustness to delay spread, and lower multipath distortion which offers an attractive solution for radio frequencies below 10 GHz.

– **OFDMA**

Orthogonal frequency-division multiple access (OFDMA) is a multiple access scheme for OFDM systems. This allows multiple users to transmit/receive simultaneously on the different subcarriers per OFDM symbol. OFDMA technology allows grouping of OFDM subcarriers into subchannels, and the allocation of each subchannel or a number of subchannels to different subscribers. For each subchannel it is possible to use different modulation schemes and coding rates, power levels, beam-forming mechanisms, MIMO support, etc. The major benefits of OFDMA include scalability, granularity, and capacity performance.

– **Usage of frequency bands above 57 GHz**

FWA systems using frequencies above 57 GHz and optical free-space systems will be able to provide further broadband applications.

Annex 1

Example of one specific BWA application

1 Introduction

This Annex describes an example of the technical aspects of the BWA application referred to in § 6.6.6. This BWA system is composed of fixed, mobile and nomadic applications including RLANs, and in total, provides integrated seamless wireless access service. The system has already been placed in service in the trains moving along the 58 km railway between Tokyo metropolitan area and Tsukuba city.

2 Service outline and system configuration

The objective of this service is to provide high-speed and BWA for the passengers on the train. Most of the wireless terminal users are making their Internet connection using PHS or cellular systems when they are out. The throughputs of such connections are currently limited to around 300 kbit/s because of the system capability. To provide broadband (on the order of Mbit/s) services to the passengers on the train, a specific BWA system employing full wireless connections has been developed.

The entire broadband service includes three kinds of wireless connections, i.e. fixed, nomadic and mobile (see Fig. 9).

Fixed BWA connections:

- Connection between the APs (access point) deployed in each compartment (Link A in Fig. 9);
- Backhaul link between intermediate APs deployed along the railway (Link B in Fig. 9).

Nomadic BWA connections:

- Indoor spot AP deployed in the train compartment or station premises (Coverage C1, C2 in Fig. 9).

Mobile BWA connection:

- Outdoor AP to provide coverage for the train moving along the railway (Coverage D in Fig. 9).

Within the scope of this Report the fixed connections are principal applications, which are particularly useful where wired infrastructure is not available along the railway or within the train.

BWA links connecting APs (Link A) could be overlaid on the existing train. This connection needs to pass through the partitions or windows between the compartments, therefore the frequency should not be very high (e.g. below 6 GHz). The transmission capacity should be sufficient enough to convey all the traffic in the train, which are connected to the WAN through the mobile BWA connection.

P-P backhaul links between intermediate APs (Link B) could operate under LoS conditions. They also provide rapid and economical wireless solutions where cable infrastructure has not been deployed. The transmission capacity should support total traffic of more than one train simultaneously operating between the stations.

The intermediate APs are equipped with both fixed and nomadic/mobile connections.

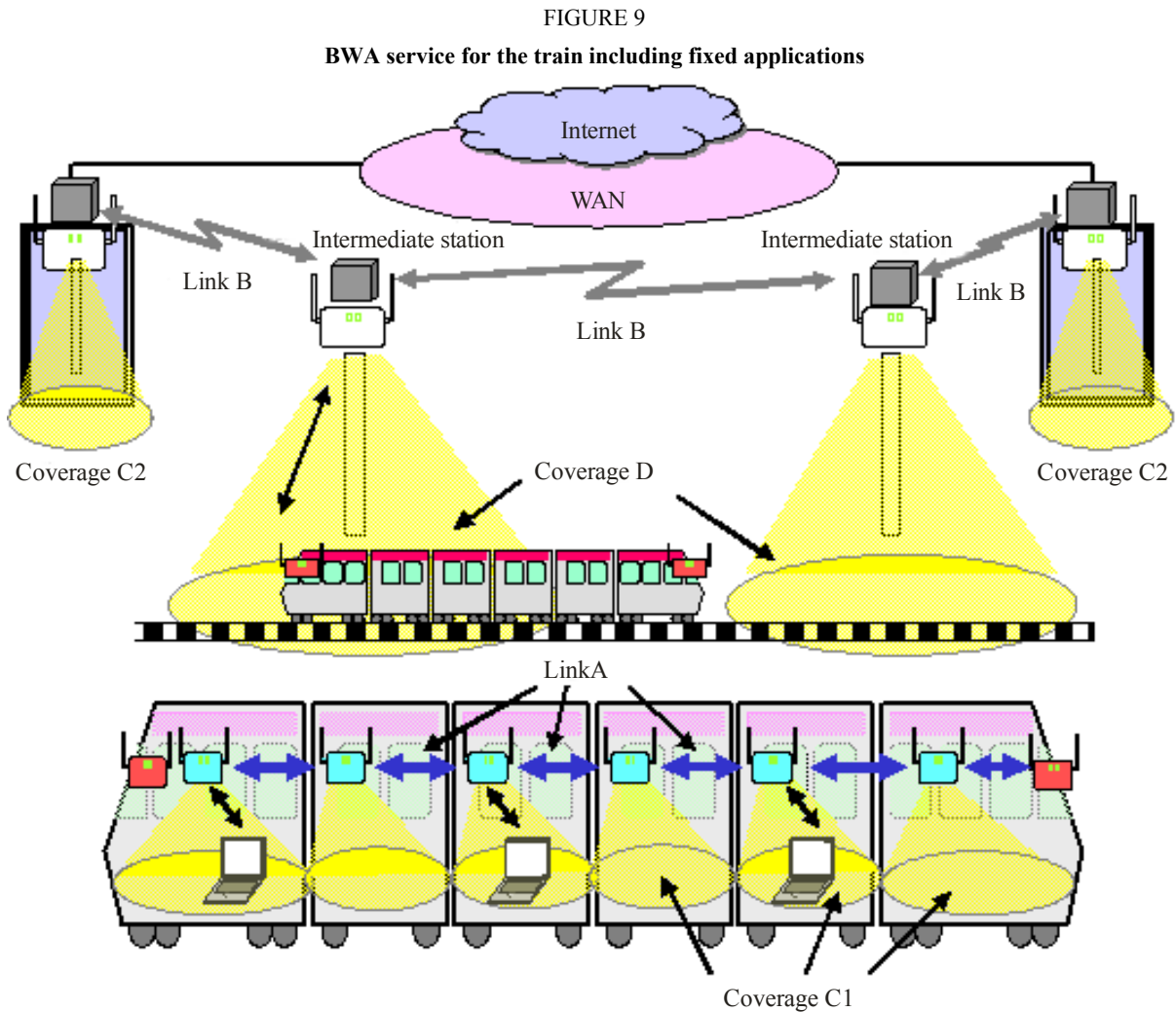

As shown in Fig.9, passengers' terminals establish their wireless connections with WiFi access points deployed in each compartment of the train. A generic 802.11b (2.4 GHz) system is used for providing end users' connections, since most terminals, such as laptop computer, PDA, WiFi phone etc., are equipped with built-in WiFi devices. The APs at each compartment could be connected by using the 5 GHz frequency. The travelling train maintains broadband wireless connection in the Coverage D in Fig. 9 using an 802.11g (2.4 GHz) system. When the train moves to another Coverage D, the train will activate a handover to keep the connection by using mobile IP technology. The mobile router mounted on the train cooperates with home agent/foreign agent and performs seamless handover within the train moving in the maximum speed of 130 km/h. Intermediate stations are connected by P-P fixed wireless systems (Link B) using the 25 GHz band.

Once passengers establish the connection to the WiFi access point at the station and receive authentication from the network by user ID and password, they will be able to access to the Internet. After they get on the train and while they are on the train, wireless Internet connection service is provided without any change of terminal settings nor additional operation (Coverage C1). When they get off the train at their destination, their connection can still be retained through the facilities deployed at the station (Coverage C2).

3 Basic system parameters

This system includes three kinds of wireless connections as depicted in Fig. 9. Basic system parameters are as follows:

- Fixed BWA connections (Link A and Link B in Fig. 9)

	Link A	Link B
Frequency band	5 GHz	25 GHz ⁽¹⁾
Transmit output power	15 dBm	0 dBm
Channel bandwidth	18 MHz	26 MHz
Channel separation	20 MHz	20 MHz
Antenna type (gain)	Omnidirectional (2.6 dBi) Directional (7 dBi)	Directional (31.5 dBi)

⁽¹⁾ Licence-exempt band in Japan

- Nomadic BWA connections (Coverages C1 and C2 in Fig. 9)

Frequency band	2.4 GHz
Transmit output power	20 dBm
Channel bandwidth	18 MHz
Channel separation	5 MHz
Antenna type (gain)	Omnidirectional (2.1 dBi)

- Mobile BWA connection (Coverage D in Fig. 9)

Frequency	2.4 GHz
Transmit output power	15 dBm
Channel bandwidth	18 MHz
Channel separation	5 MHz
Antenna type (gain)	Directional (6-19 dBi)

4 Fixed BWA connections

4.1 Connection between APs in the train

Link A in Fig. 9 needs to operate under the NLoS condition because the facilities are set up at the upper part of the compartment to avoid blockage from passengers and, in addition, the partitions between the compartments become obstacles. Therefore, the frequency should not be very high taking into account the propagation characteristics. In this system, the 5 GHz band is used for Link A. Since multipath fading is caused by movement of the train and passengers, the AP has two-branch space diversity antennas to cope with this fading.

4.2 Backhaul links between the intermediate stations

The system requires intermediate stations to cover the whole area along the railway. The intermediate station should be set up every 1-2 km, since the radius of Coverage D is limited up to 1 km. To deploy them rapidly and cost effectively, it is indispensable to use fixed wireless systems as backhaul links instead of optical fibre network. Large capacity would be required for the link to transmit the traffic for more than one train located in the coverage area. A 25 GHz P-P system with the maximum capacity of 80 Mbit/s is used for the backhaul links. Directive antennas are set up at the roof top of the buildings or at the top of electricity poles to keep LoS. In the case of Tsukuba Express railway, there are 20 stations and 30 intermediate stations along the 58 km railway to cover the whole area.

5 Connection to a WAN

At each railway station optical fibre is employed to carry the whole traffic generated at the station and on the train. The broadband traffic is connected to a WAN via two gateway stations to ensure the connectivity to the Internet.

Annex 2

Example of integrated BWA application in rural area

1 Introduction

This Annex describes another example of the technical aspects of the BWA application referred to in § 6.6.6. This BWA system is composed of fixed and nomadic applications including RLANs, and is particularly useful in the environments where cable infrastructure is not deployed.

The integrated BWA system could be installed flexibly to a rural area, where multiple clusters of users are scattered widely in a remote community, at lower cost compared with a new network cable infrastructure.

In addition, an NWA service in an outdoor environment could be provided with portable VoIP terminals, personal digital assistants (PDAs) etc.

2 System configuration

The objective of this service is to provide broadband access for residents in a rural area in the distance from the core networks. In such an area several households are scattered widely and cannot be covered by one AP of RLAN alone. As shown in § 6.3.4, by sharing the BWA system integrated with P-P solutions and P-MP networks, many users can obtain Internet connection.

The broadband service includes three kinds of wireless connection, i.e. backhaul link, relay link and access link (see Fig. 10).

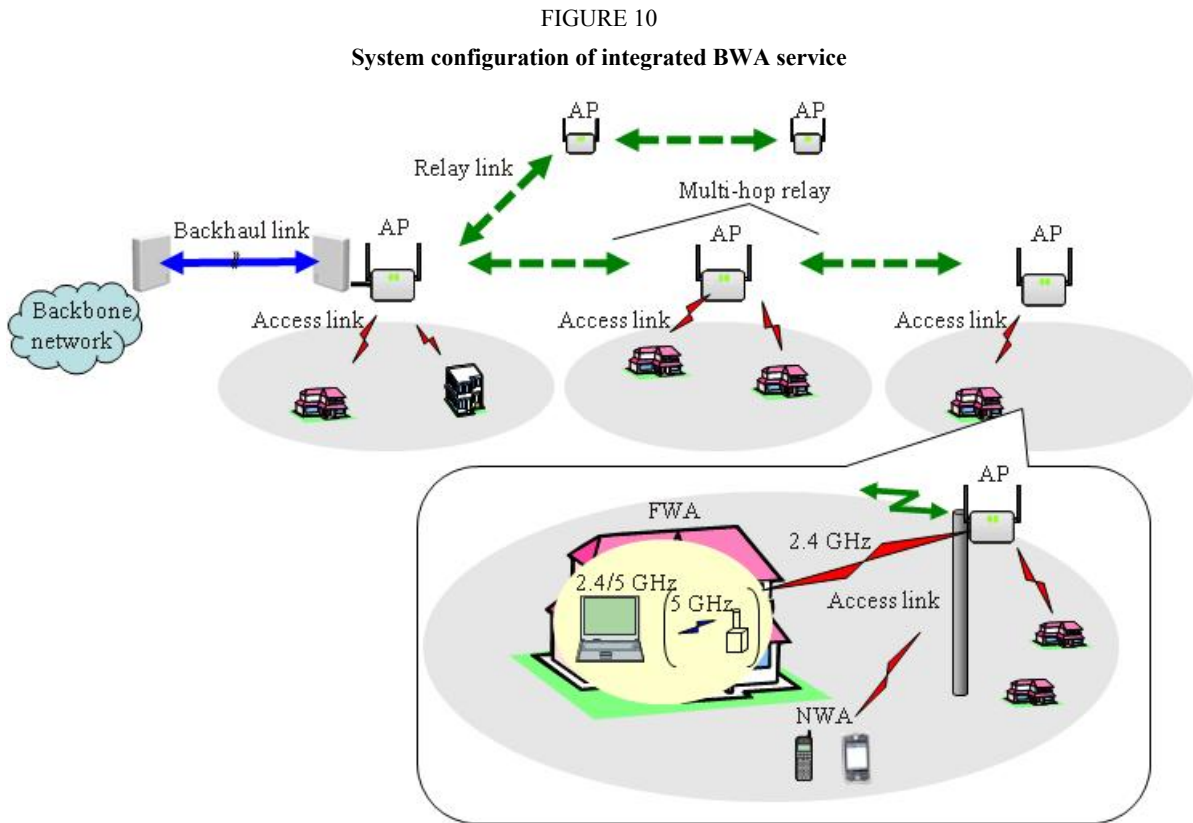

Backhaul link

- P-P connection is deployed between the APs placed in a service area and a backbone network.
- The distance is a few kilometres with a clear LoS path, and can be extended by arranging several P-P connections according to the geographical conditions in case of need.

Relay link

- P-MP connection is deployed between each AP in a service area.
- The distance is hundreds of metres under LoS conditions, and can be deployed by multi-hop relay techniques with P-MP topology structure.

Access link

- P-MP connections are directly deployed between an outdoor AP and indoor SUs, such as note PCs or repeaters.
- The distance is a few hundred metres under non-LoS conditions.

Two types of wireless system are applicable to backhaul link. If the number of the subscriber is large, the backhaul link needs large transmission capacity. 25 GHz band is a proper solution to support total traffic of several RLAN users in AP areas, since it has the maximum capacity of 80 Mbit/s and performance of transmission distance of a few kilometres. On the contrary, if the number of the subscriber is not large, IEEE 802.11j (4.9-5.0 GHz) or IEEE 802.11b/g (2.4 GHz) may also be as backhaul link, if its transmission capacity is enough to support total traffic.

There are two types of multi-hop relay for the relay link, one is called dual-radio; the APs use the same frequency channel in the multi-hop relay. Though the AP of dual-radio is available at low cost, it has a disadvantage that the throughput of the relay link decreases as the number of hopping increases. The other type is called multi-radio; the APs are mounted more than two radio modules, and maintain the throughput of the relay link in any number of hopping.

The outdoor APs could be placed on the top of a pole, and make connections to the SUs in houses directly using IEEE 802.11 b/g (2.4 GHz). When the direct connection between the AP and the SU is difficult, it is useful to establish an access link via a radio repeater which converts a radio frequency channel to another radio channel, for example, in switching from IEEE 802.11 b/g (2.4 GHz) to IEEE 802.11a (5.2-5.3 GHz).

3 Basic system parameters

This system includes three kinds of wireless link as depicted in Fig. 10. Basic system parameters are as follows:

TABLE 5
Basic system parameters to integrated BWA

Link	Backhaul link			Relay link			Access link
Frequency (GHz)	25 ⁽¹⁾	4.9-5.0	2.4	5.6	4.9-5.0	2.4	2.4
Transmit output power (dBm)	0	20	11	12	15	20	20
Channel bandwidth (MHz)	26	18	18	18	18	18	18
Channel separation (MHz)	20	20	20	20	20	20	20
Antenna type	Directional			Omnidirectional			Omnidirectional
Antenna gain (dBi)	31.5	13	19	6	6	5	5

⁽¹⁾ Unlicensed band in Japan.

4 Feasibility test

The field test of this system has already been conducted in a rural community in Miyagi Prefecture, Japan. At the field test, the relay link was composed of 2-hop relay by using IEEE 802.11j of 4.9-5.0 GHz band. Various applications such as Internet access, IP announcement, and VoIP were achieved relatively low budget. The throughput of the note PCs connected to the 3rd AP was obtained more than 3 Mbit/s.

Annex 3

Example of BWA system providing high quality service applications

1 Introduction

This Annex describes example of BWA system providing HQSAs, hereinafter called HQSA BWA, referred to in § 6.10.

2 Service images

Figure 11 shows a service image configuration of HQSA BWA. This type of network has a considerable cost advantage compared to FTTH in a low-density residential area in rural or sub-urban areas. This system can be topologically configured with a point-to-multipoint (P-MP) or a point-to-point (P-P) connection.

A radio backhaul link using a P-P connection can be used in rural areas where an optical fibre system is located from afar.

A P-MP system with an omnidirectional AP antenna is mainly deployed for detached houses scattering in a service area. The service area radius is approximately 1 km, which depends on service availability objective and regional rain conditions.

A P-MP system is also applied to a multi-dwelling building which is not equipped with available wiring ducts in urban areas. A horn antenna is implemented in such multi-dwelling buildings.

Multiple IP-based user terminals, such as PCs, can be accommodated by a wireless terminal (WT). It is easy to deploy this type of system and is cost effective because WTs are very compact; 19 cm × 19 cm × 3 cm, and low cost.

FIGURE 11
Service image

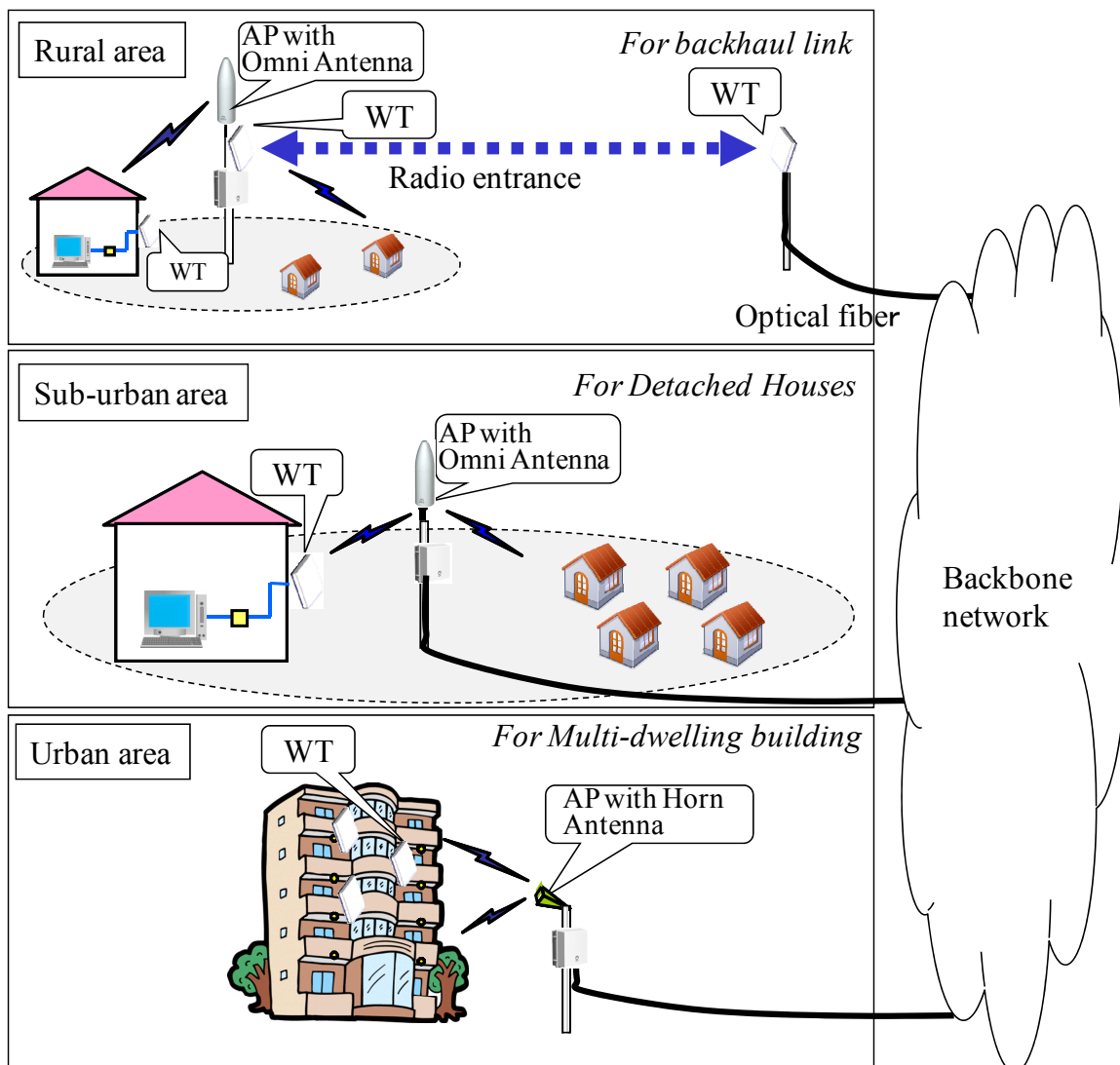

3 Main specifications and comparison to conventional BWA

Table 6 gives the main specifications for the HQSA BWA system with comparison to conventional BWA, whose parameters are proposed to be listed as one of the typical BWA systems in Recommendation ITU-R F.758 used for a sharing study.

The operating frequencies for the system are the various frequencies regulated by organizations. The radio-frequency arrangements comply with Annex 3 of Recommendation ITU-R F.748.

The HQSA BWA system can newly employ high-level modulation schemes (64-QAM) and high-speed symbol rate (40 MHz) to achieve high-speed transmission of 240 Mbit/s. The media access control protocol enables a throughput of approximately 180 Mbit/s. A new minimum guaranteed bandwidth, rate limit, and priority queuing function are supported to achieve high-quality VoIP service comparable to POTs.

TABLE 6
Main specifications and comparison to conventional BWA

Items	HQSA BWA	Conventional BWA
Frequency	24.5-27 GHz band	26 GHz band
Channel bandwidth	52 MHz	26 MHz
Symbol rate	40 MHz	20 MHz
Modulation	QPSK, 16-QAM, 64-QAM	QPSK, 16-QAM
Physical data rate	240 Mbit/s	80 Mbit/s
Transmission speed	Approximately 180 Mbit/s (DownLink/UpLink)	Approximately 46 Mbit/s (DownLink)
Transmission scheme	TDM/TDMA/Dynamic TDD	
Antenna type	AP: Omnidirectionnal, WT: Planar	
Antenna gain	AP: 6 dBi, WT: 31 dBi	
Adaptative modulation	Supported	
Priority queuing	Supported	Not supported
Multicast	Supported	Not supported
Available services	Internet, VoIP service compatible to POTs, HDTV streaming	Internet