

International Telecommunication Union

ITU-R
Radiocommunication Sector of ITU

Report ITU-R BT.2254-3
(03/2017)

**Frequency and network planning
aspects of DVB-T2**

BT Series
Broadcasting service
(television)



International
Telecommunication
Union

Foreword

The role of the Radiocommunication Sector is to ensure the rational, equitable, efficient and economical use of the radio-frequency spectrum by all radiocommunication services, including satellite services, and carry out studies without limit of frequency range on the basis of which Recommendations are adopted.

The regulatory and policy functions of the Radiocommunication Sector are performed by World and Regional Radiocommunication Conferences and Radiocommunication Assemblies supported by Study Groups.

Policy on Intellectual Property Right (IPR)

ITU-R policy on IPR is described in the Common Patent Policy for ITU-T/ITU-R/ISO/IEC referenced in Annex 1 of Resolution ITU-R 1. Forms to be used for the submission of patent statements and licensing declarations by patent holders are available from <http://www.itu.int/ITU-R/go/patents/en> where the Guidelines for Implementation of the Common Patent Policy for ITU-T/ITU-R/ISO/IEC and the ITU-R patent information database can also be found.

Series of ITU-R Reports

(Also available online at <http://www.itu.int/publ/R-REP/en>)

Series	Title
BO	Satellite delivery
BR	Recording for production, archival and play-out; film for television
BS	Broadcasting service (sound)
BT	Broadcasting service (television)
F	Fixed service
M	Mobile, radiodetermination, amateur and related satellite services
P	Radiowave propagation
RA	Radio astronomy
RS	Remote sensing systems
S	Fixed-satellite service
SA	Space applications and meteorology
SF	Frequency sharing and coordination between fixed-satellite and fixed service systems
SM	Spectrum management

Note: This ITU-R Report was approved in English by the Study Group under the procedure detailed in Resolution ITU-R 1.

Electronic Publication
Geneva, 2017

© ITU 2017

All rights reserved. No part of this publication may be reproduced, by any means whatsoever, without written permission of ITU.

REPORT ITU-R BT.2254-3

Frequency and network planning aspects of DVB-T2

(2012-2013-2014-2017)

DVB-T2 is a 2nd generation terrestrial broadcast transmission system developed by DVB project since 2006. The main purpose was to increase capacity, ruggedness and flexibility to the DVB-T system. The first version was published by ETSI as EN 302 755 in 2009.

This Report provides guidance on frequency and network planning of DVB-T2. It has been developed by EBU Members involved in planning of DVB-T2 networks. It is intended to help broadcast network operators in their planning and administrations in defining the most suitable set of parameters from the large possibilities offered by the DVB-T2 system.

In its present form, it has been published as EBU Tech 3348 ‘Frequency and network aspects of DVB-T2’.

TABLE OF CONTENTS

	<i>Page</i>
1 Introduction	4
1.1 Commercial requirements for DVB-T2	4
1.2 DVB-T and DVB-T2; what is the difference?	4
1.3 Notes on this Report	5
2 System properties	6
2.1 Bandwidth	6
2.2 FFT size	7
2.3 Modulation scheme and guard interval	8
2.4 Available data rate	9
2.5 Carrier-to-noise ratio (<i>C/N</i>)	11
2.6 Rotated constellation	20
2.7 Scattered pilot patterns	23
2.8 Time interleaving	27
2.9 Bandwidth extension	28
2.10 Phase noise	29
2.11 Choice of system parameters	29
3 Receiver properties, sharing and compatibility, network planning parameters	31
3.1 Minimum receiver signal input levels	31

	<i>Page</i>
3.2	Signal levels for planning 32
3.3	Examples of signal levels for planning..... 33
3.4	Protection ratios 40
3.5	DVB T2 equalization interval (EI) 47
4	New planning features 50
4.1	SFN extension..... 50
4.2	Degradation beyond guard interval..... 58
4.3	MISO (multiple input single output) 60
4.4	Time-frequency slicing (TFS) 66
4.5	Time slicing 71
4.6	Physical layer pipes 71
4.7	Peak-to-average power ratio (PAPR) reduction techniques 74
4.8	Future extension frames (FEF) 74
5	Implementation scenarios 75
5.1	Introduction..... 75
5.2	Scenario 1: MFN rooftop reception and a transition case 75
5.3	Scenario 2: SFN rooftop reception, maximum coverage..... 76
5.4	Scenario 3: SFN rooftop reception, moderate coverage 76
5.5	Scenario 4: Portable reception (maximum data rate)..... 78
5.6	Scenario 5: Portable reception (maximum coverage area extension)..... 79
5.7	Scenario 6: Portable reception (optimal spectrum usage) 79
5.8	Scenario 7: Mobile reception (1.7 MHz bandwidth in Band III) 80
5.9	Scenario 8: Portable and mobile reception (common MUX usage by different services) – Multiple PLPs 80
5.10	Overview of scenarios 81
6	Transition to DVB-T2 83
6.1	DVB-T2 in GE06..... 83
6.2	Transition scenarios 85
7	References 88
	Annex 1 – Planning methods, criteria and parameter 90
A1.1	Reception modes..... 90

	<i>Page</i>
A1.2 Coverage definitions	92
A1.3 Calculation of signal levels.....	93
Annex 2 – Estimation of the net data capacity of a DVB-T2 multiplex.....	101
Annex 3 – Nyquist time for frequency and time interpolation vs. guard interval	111
Annex 4 – Derivation and comparison of <i>C/N</i> values	113
A4.1 Raw values of <i>C/N</i> for the derivation of the Rice and Rayleigh Channel Case .	113
A4.2 Comparison of <i>C/N</i> values calculated according to the methodology of § 2.5 and measurement results.....	114
Annex 5 – DVB-T2-Lite	120
A5.1 Introduction.....	120
A5.2 Differences between T2-Base and T2-Lite.....	120
A5.3 DVB-T2-Lite signal structure.....	120
A5.4 DVB-T2-Lite system parameters.....	121
A5.5 DVB-T2-Lite planning parameters.....	122
A5.6 Implementation aspects and implementation scenarios.....	124
Annex 6 – Further understanding the DVB-T2 Equalisation Interval	124
Attachment to Annex 6 – Spectrum plots of a main DVB-T signal and a single echo.....	130
Annex 7 – Specific implementation scenarios/Country situation	131
A7.1 DVB-T2 in the UK (October 2013).....	131
A7.2 DVB-T2 in Finland (October 2013)	135
A7.3 Introduction of DVB-T2 in Sweden	135
A7.4 DVB-T2 in Denmark (October 2013).....	137
A7.5 DVB-T2 in Austria (October 2013).....	138
A7.6 Introduction of DVB-T2 with HEVC in Oman	140

1 Introduction

DVB-T2 is the 2nd generation standard for digital terrestrial TV, offering significant benefits compared to DVB-T.

The emergence of DVB-T2 is motivated by the higher spectral efficiency going along with DVB-T2 – be it for a transition from analogue TV to DVB-T2, be it for a transition from DVB-T to DVB-T2. Higher spectral efficiency means that with the same amount of spectrum, a larger number of programmes can be broadcast or the same number of programmes broadcast with a higher audio/video quality or coverage quality.

If in addition improved source coding (MPEG-4) is employed, the gain in broadcast transmission is remarkable. For example, in [BG2009] it is shown that a doubling of the number of programmes that can be accommodated in one multiplex is possible (while keeping the same audio/video quality). Also the transmission of more programmes in HD quality would become possible.

Alternatively, the coverage area of a digital terrestrial television (DTT) transmitter can be largely increased while keeping constant the transmitter characteristics as well as the reception mode, video quality and number of programmes.

1.1 Commercial requirements for DVB-T2

The commercial requirements for DVB-T2 [TS 102 831] included:

- DVB-T2 transmissions must be able to use existing domestic receive antenna installations and must be able to reuse existing transmitter infrastructures. This requirement ruled out the consideration of MIMO techniques which would involve both new receive and transmit antennas.
- DVB-T2 should primarily target services to fixed and portable receivers.
- DVB-T2 should provide a minimum of 30% capacity increase over DVB-T working within the same planning constraints and conditions as DVB-T.
- DVB-T2 should provide for improved single frequency network (SFN) performance compared with DVB-T.
- DVB-T2 should have a mechanism for providing service-specific robustness; i.e. it should be possible to give different levels of robustness to some services compared to others. For example, within a single 8 MHz channel, it should be possible to target some services for rooftop reception and target other services for reception on portables.
- DVB-T2 should provide for bandwidth and frequency flexibility.
- There should be a mechanism defined, if possible, to reduce the peak-to-average-power ratio of the transmitted signal in order to reduce transmission costs.

1.2 DVB-T and DVB-T2; what is the difference?

Compared to DVB-T, DVB-T2 COFDM parameters have been extended to include:

- New generation forward error correction (FEC) (error protection) and higher constellations (256-QAM) resulting in a capacity gain of 25-30%, approaching the Shannon limit.
- OFDM carrier increase from 8k to 32k. In SFN, the guard interval of 1/16 instead of 1/4 resulting in an overhead gain of ~18%.
- New guard interval fractions: 1/128, 19/256, 19/128.
- Scattered pilot optimization according to the guard interval (GI), continual pilot minimization resulting in an overhead reduction of ~10%.
- Bandwidth extension: e.g. for 8 MHz bandwidth, 7.77 MHz instead of 7.61 MHz (2% gain).

- Extended interleaving including bit, cell, time and frequency interleaving.

The extended range of COFDM parameters allows very significant reductions in overhead to be achieved by DVB-T2 compared with DVB-T, which taken together with the improved error-correction coding allows an increase in capacity of up to nearly 50% to be achieved for MFN operation and even higher for SFN operation.

DVB-T2 also allows for three new signal bandwidths: 1.7 MHz, 5 MHz and 10 MHz.

The DVB-T2 system also provides a number of new features for improved versatility and ruggedness under critical reception conditions such as:

- rotated constellations, which provide a form of modulation diversity, to assist in the reception of higher code-rate signals in demanding transmission channels,
- special techniques to reduce the peak-to-average power ratio (PAPR) of the transmitted signal resulting in a better efficiency of high power amplifiers,
- multiple input single output (MISO) transmission mode using a modified form of Alamouti encoding.

At the physical layer, time slicing is included enabling power saving and allowing different physical layer pipes to have different levels of robustness. Sub-slicing within a frame is also possible which increases time diversity/interleaving depth without increasing de-interleaving memory.

1.3 Notes on this Report

The purpose of this Report is to collect information relevant to network and frequency planning for DVB-T2. It is complementary information to the ETSI system specification [EN 302 755] and implementation guideline [TS 102 831] and the corresponding DVB Blue Books [A122], [A133]. Some of the information in these system documents is inevitably repeated here.

Section 2 describes some elementary system properties relevant for network and frequency planning. Section 3 deals with receiver properties, sharing and compatibility, and network planning parameters. These are to be understood as to serve for frequency and network planning purposes and not as an addition to receiver specifications. Section 4 covers new planning features that are possible with DVB-T2 as compared to DVB-T. Section 5 collects several typical implementation scenarios, for fixed reception, for portable and mobile reception. Finally, § 6 describes some aspects of the transition to DVB-T2.

Annex 1 covers planning aspects that are not specific to DVB-T2 but which are nonetheless required for frequency and network planning. Annexes 2, 3 and 6 deal with some technical details of DVB-T2. Annex 4 compares C/N values proposed for use in planning with measurement results. The extension of the DVB-T2 specification to make it particularly suitable for mobile reception, called DVB-T2-Lite, is described in Annex 5. Annex 7 summarizes the status of DVB-T2 adoption in various European countries.

The present edition of the Report is version 2 and updates version 1 of 2013.

Annex 5 on DVB-T2-Lite has been revised and supplemented. In addition, the raw C/N values for a Gaussian channel in § 2.5 have been adapted to the simulation results reported in the Implementation Guidelines [TS 102 831] where perfect channel estimation, perfect synchronization and no phase noise was assumed – instead of, as for the previous versions of this report, the simulation results for a memoryless Rayleigh channel with erasures, which are also reported in the Implementation Guidelines. This change slightly impacts several planning figures given in §§ 2.5, 3 and 5. Other sections have not been revised, thus giving information as of the publication date of version 2 (November 2013).

Version 2 was an update of version 1 of 2012. There, Table 3.1 and the Tables in §§ 3.3.1 and 3.3.2 were corrected. Table A3.1 in Annex 3 was also corrected and brought into a clearer form. Section 3.4 on protection ratios was updated with more recent information from Recommendation ITU-R BT.2033 which includes the most up-to-date measurements results of protection ratios and overload thresholds. Annex 6 was introduced to provide more information about the sharp transition at the edge of the equalisation interval (EI). In § 4.3 on MISO, results from measurements were included and a clearer assessment of this DVB-T2 feature is given. In addition, some typographical errors were corrected.

As compared to the time of version 1 (September 2012) the situation with regard to information on planning parameters and criteria is more consolidated. Additional laboratory and field measurements have been taken, and in further countries regular DVB-T2 services have been started. Nonetheless, there remain aspects where still additional information is required. This is particularly the case for C/N values in time-variant Rayleigh channels, but also for network implementation aspects particular to DVB-T2 and the DVB-T2 receiver behaviour and performance in SFNs. Therefore, further update of this Report will be required to include this missing or incomplete information when it becomes available.

Similarly, the feasibility of DVB-T2 for audio broadcasting is not dealt with in detail in this Report. This aspect will also be covered in a further revision.

A short and concise overview of the DVB-T2 system parameters is given in Recommendation ITU-R BT.1877. A general textbook on DVB-T2 is, e.g. [F2010], where also information on frequency and network planning aspects of DVB-T2 can be found.

In several of the tables the entry *n/a* means that no data is currently available for the parameter.

2 System properties

Compared with DVB-T, the DVB-T2 standard offers a bigger choice of the OFDM parameters and modulation schemes. The available bandwidths are also increased. Combining various modulation schemes with Fast Fourier Transform (FFT) sizes and guard intervals allows construction of MFN and SFN networks designed for different applications: from low bit-rate but robust mobile reception to the high bit-rate fixed reception for domestic and professional use.

This section gives a short overview of the DVB-T2 system parameters. More information on DVB-T and DVB-T2 system parameters can be found in [TR 102 831, EN 302 755, EN 300 744].

2.1 Bandwidth

There are three additional bandwidths available as compared to DVB-T, see Table 2.1.

TABLE 2.1
Channel bandwidths for DVB-T and DVB-T2

DVB-T	DVB-T2
–	1.7 MHz
–	5 MHz
6 MHz	6 MHz
7 MHz	7 MHz
8 MHz	8 MHz
–	10 MHz

2.2 FFT size

While for DVB-T two FFT sizes, 2k and 8k, are specified, DVB-T2 comprises 1k, 2k, 4k, 8k, 16k and 32k FFT sizes. Table 2.2 shows the available FFT sizes for the 8 MHz variant.

TABLE 2.2
FFT size parameters for DVB-T2/8 MHz (from [EN 302 755])

Parameter		1k mode	2k mode	4k mode	8k mode	16k mode	32k mode
Number of carriers, K_{total}	normal carrier mode	853	1705	3409	6817	13633	27265
	extended carrier mode	<i>n/a</i>	<i>n/a</i>	<i>n/a</i>	6913	13921	27841
Value of carrier number, K_{min}	normal carrier mode	0	0	0	0	0	0
	extended carrier mode	<i>n/a</i>	<i>n/a</i>	<i>n/a</i>	0	0	0
Value of carrier number, K_{max}	normal carrier mode	852	1704	3408	6816	13632	27264
	extended carrier mode	<i>n/a</i>	<i>n/a</i>	<i>n/a</i>	6912	13920	27840
Number of carriers added on each side in extended carrier mode, K_{ext} (see Note 2)		0	0	0	48	144	288
Duration, T_U (for T , see Table 2.3)		1024T	2048T	4096T	8192T	16384T	32768T
Duration, T_U μ s (see Note 3)		112	224	448	896	1792	3584
Carrier spacing $1/T_U$ (Hz) (see Notes 1 and 2)		<i>8929</i>	<i>4464</i>	<i>2232</i>	<i>1116</i>	<i>558</i>	<i>279</i>
Spacing between carriers K_{min} and K_{max} ($K_{total}-1$)/ T_U (see Note 3)	normal carrier mode	<i>7.61 MHz</i>	<i>7.61 MHz</i>	<i>7.61 MHz</i>	<i>7.61 MHz</i>	<i>7.61 MHz</i>	<i>7.61 MHz</i>
	extended carrier mode	<i>n/a</i>	<i>n/a</i>	<i>n/a</i>	<i>7.71 MHz</i>	<i>7.77 MHz</i>	<i>7.77 MHz</i>

NOTE 1 – Numerical values in italics are approximate values.

NOTE 2 – This value is used in the definition of the pilot sequence in both normal and extended carrier mode.

NOTE 3 – Values for 8 MHz channels.

In Table 2.2 the parameters which are bandwidth dependent are given as a function of T_U which is a function of the elementary period T . Explicitly shown are the values for the 8 MHz variant. Table 2.3

gives the absolute values of T for all the available bandwidths. With these the parameter values for the other bandwidths can be calculated.

TABLE 2.3

Elementary period as a function of bandwidth (from [EN 302 755])

Bandwidth	1.7 MHz	5 MHz	6 MHz	7 MHz	8 MHz	10 MHz (see Note)
Elementary period, T	71/131 μ s	7/40 μ s	7/48 μ s	1/8 μ s	7/64 μ s	7/80 μ s

NOTE – This configuration is only intended for professional applications and is not expected to be supported by domestic receivers.

2.3 Modulation scheme and guard interval

In DVB-T2, the additional 256-QAM modulation scheme is available, see Table 2.4. The new error protection techniques allow the usage of such high modulation schemes.

TABLE 2.4

Modulation schemes for DVB-T and DVB-T2

DVB-T	DVB-T2
QPSK	QPSK
16-QAM	16-QAM
64-QAM	64-QAM
–	256-QAM

TABLE 2.5

Length of guard interval for DVB-T2 in an 8 MHz channel raster

		GI-Fraction						
		1/128	1/32	1/16	19/256	1/8	19/128	1/4
FFT	T_U (ms)	GI (μ s)						
32k	3.584	28	112	224	266	448	532	<i>n/a</i>
16k	1.792	14	56	112	133	224	266	448
8k	0.896	7	28	56	66.5	112	133	224
4k	0.448	<i>n/a</i>	14	28	<i>n/a</i>	56	<i>n/a</i>	112
2k	0.224	<i>n/a</i>	7	14	<i>n/a</i>	28	<i>n/a</i>	56
1k	0.112	<i>n/a</i>	<i>n/a</i>	7	<i>n/a</i>	14	<i>n/a</i>	28

TABLE 2.6

Length of guard interval for DVB-T2 in a 7 MHz channel raster

		GI-Fraction						
		1/128	1/32	1/16	19/256	1/8	19/128	1/4
FFT	T_U (ms)	GI (μ s)						
32k	4.096	32	128	256	304	512	608	<i>n/a</i>
16k	2.048	16	64	128	152	256	304	512
8k	1.024	8	32	64	76.0	128	152	256
4k	0.512	<i>n/a</i>	16	32	<i>n/a</i>	64	<i>n/a</i>	128
2k	0.256	<i>n/a</i>	8	16	<i>n/a</i>	32	<i>n/a</i>	64
1k	0.128	<i>n/a</i>	<i>n/a</i>	8	<i>n/a</i>	16	<i>n/a</i>	32

Also additional guard interval fractions are available in DVB-T2. A suitable combination of symbol length (i.e. FFT mode) and guard interval fraction allows for the minimization of the overhead implied by the guard interval.

In Tables 2.5-2.7 the various guard interval fractions are described for an 8, 7 and 1.7 MHz bandwidth.

TABLE 2.7

Length of guard interval for DVB-T2 in a 1.7 MHz channel raster

		GI-Fraction						
		1/128	1/32	1/16	19/256	1/8	19/128	1/4
FFT	T_U (ms)	GI (μ s)						
8k	4.440	34.7	138.7	277.5	329.5	555.0	659.1	1110.0
4k	2.220	<i>n/a</i>	69.4	138.7	<i>n/a</i>	277.5	<i>n/a</i>	555.0
2k	1.110	<i>n/a</i>	34.7	69.4	<i>n/a</i>	138.7	<i>n/a</i>	277.5
1k	0.555	<i>n/a</i>	<i>n/a</i>	34.7	<i>n/a</i>	69.4	<i>n/a</i>	138.7

2.4 Available data rate

Tables 2.5, 2.6 and 2.7 show the large number of possible modes in DVB-T2. Some of the 2k and 8k modes are the same as in DVB-T. The main difference is the addition of 16k and 32k FFT.

TABLE 2.8

**Maximum bit-rate and recommended configurations for 8 MHz,
32k 1/128, PP7 (from [TS 102 831])**

Modulation	Code rate	Absolute maximum bit-rate			Recommended configuration		
		Bit rate Mbit/s	Frame length, L_F	FEC blocks per frame	Bit rate Mbit/s	Frame length, L_F	FEC blocks per frame
QPSK	1/2	7.49255	62	52	7.4442731	60	50
	3/5	9.003747			8.9457325		
	2/3	10.01867			9.9541201		
	3/4	11.27054			11.197922		
	4/5	12.02614			11.948651		
	5/6	12.53733			12.456553		
16-QAM	1/2	15.03743	60	101	15.037432	60	101
	3/5	18.07038			18.07038		
	2/3	20.10732			20.107323		
	3/4	22.6198			22.619802		
	4/5	24.13628			24.136276		
	5/6	25.16224			25.162236		
64-QAM	1/2	22.51994	46	116	22.481705	60	151
	3/5	27.06206			27.016112		
	2/3	30.11257			30.061443		
	3/4	33.87524			33.817724		
	4/5	36.1463			36.084927		
	5/6	37.68277			37.618789		
256-QAM	1/2	30.08728	68	229	30.074863	60	202
	3/5	36.15568			36.140759		
	2/3	40.23124			40.214645		
	3/4	45.25828			45.239604		
	4/5	48.29248			48.272552		
	5/6	50.34524			50.324472		

This will result in a two and four times longer “useful” symbol time compared to the 8k case, i.e. at UHF (8 MHz channel raster) 2 and 4 times 896 μ s (1792 μ s and 3584 μ s).

The very long symbol time will, in principle, result in a poorer Doppler performance, due to the short inter-carrier distance in the OFDM signal. The 32k mode is therefore aimed mainly at fixed rooftop reception. Laboratory and field tests indicate that the 32k mode is unlikely to be used to provide mobile (vehicular) reception at UHF. Even in a portable (indoor or outdoor pedestrian) receiving environment with relatively low Doppler frequencies it needs to be confirmed that the 32k mode is suitable. The Doppler performance is however up to 4 times better at VHF compared to UHF Band V. This fact may make VHF Band III frequencies interesting for providing mobile services using the DVB-T2 system.

One additional difference between DVB-T and DVB-T2 is the increased number of GI fraction using 1/128, 19/256 and 19/128, which gives further possibilities to adopt the length of the guard interval to the size of the SFN.

As an example, Table 2.8 and Fig. 2.1 show the maximum bit-rate and recommended configurations for the system variant 8 MHz, 32k 1/128, PP7.

FIGURE 2.1
Maximum bit rate and bit rate for recommended configuration
with 8 MHz bandwidth and 32k PP7 (from [TS 102 831])

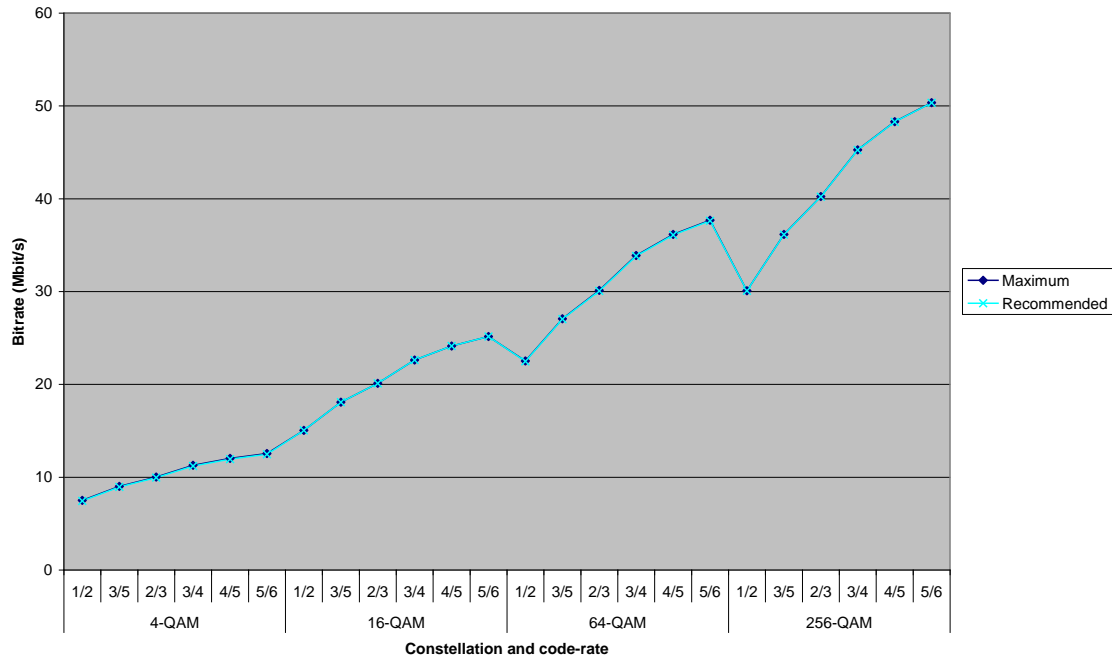

A more comprehensive overview of the available data rates for the various DVB-T2 configurations is given in Annex 2.

Two parameters of the transmitted signal related to the FFT size of the OFDM modulation can influence planning of the DVB-T2 network:

- inter-carrier spacing;
- symbol duration.

Increasing the FFT size results in a narrower sub-carrier spacing and consequently in a longer symbol duration.

Further considerations on the suitable choice of a DVB-T2 configuration are described in § 2.11.

2.5 Carrier-to-noise ratio (C/N)

2.5.1 Introduction

The C/N characterizes the robustness of transmission systems with regard to noise and interference. As such it is used to determine the signal level required to receive a viable signal in noise and interference limited channels. Subsequently, the determination of the C/N is of fundamental importance for network planning.

At the time of writing insufficient measurements of receivers were available to provide an experimentally determined C/N representative of the receiver population. In lieu of measurements this section describes a methodology that can be used to calculate the C/N based upon the simulated receiver performance results provided in the DVB-T2 Implementation Guideline [TS 102 831]. The methodology proposed compares favourably with the limited measurements compiled to date in Annex 4, though it may be slightly conservative.

The methodology proposed here is similar to the one proposed for adoption in a coming update of the IEC 62216 E-book [IEC 62216] and aligns in general with the Nordig receiver specification [NorDig2013] without being identical with either of these two approaches. It is important to note that the C/N ratios derived using the following methodology are understood to describe the average behaviour of receivers which can be used for frequency and network planning. They are not intended to describe minimum receiver requirements in the sense of a specification.

This section also provides some background on the common reception channels that are encountered in broadcast network planning so that the correct C/N can be determined for the targeted receiving environment.

The full methodology for determining the C/N of a given mode and receiving environment is described below.

2.5.2 Methodology for the derivation of the C/N

The following main steps are usually necessary when determining the C/N to be used for planning:

- Step 1: Identify the target receive environment to determine the reception channel. This means identifying whether the network is aimed at fixed rooftop reception, portable indoor, portable outdoor or mobile reception, and for example, will lead to determining whether the C/N for a Ricean or Rayleigh channel is most appropriate.
- Step 2: Choose the DVB-T2 transmission mode. This step usually involves an iterative process where the requirements of capacity, coverage and cost are traded off or optimized. When a DVB-T2 mode is chosen, the simulation based C/N for a Gaussian channel ($C/N_{Gauss-raw}$) can be found in Table 2.9 and used as the base value for the proposed method.
- Step 3: Apply the methodology described in the following sections to adjust the identified $C/N_{Gauss-raw}$ to correct it for real receiver implementation factors and to match it to the identified transmission channel and receiving environment.

2.5.3 Common reception channels

The main reception channels that are encountered in terrestrial broadcasting are briefly described below. Each of these will require a certain C/N that reflects how demanding the channel is for the receiver. The derivation of the final C/N is described in the following sections.

- Gaussian channel (AWGN): This channel is characterized by a single wanted signal with no channel perturbations where only Gaussian noise is present. It is the least demanding channel and is normally used only as a reference, not in practical network planning.
- Ricean channel: Used for planning fixed rooftop reception where there is predominantly a single direct signal and smaller amplitude reflections.
- Rayleigh channel(s):
 - i) **Rayleigh static channel:** Mainly used for planning portable indoor and outdoor reception. In this channel model the received signals consist only of a number of reflected signals – no direct signal is present. The simulations in the DVB-T2 ETSI Implementation Guideline [TS 102 831, Table 39] use a Rayleigh channel with 20 static paths. Due to the static nature of this channel model it should be regarded as a ‘best case’ when planning for portable reception and should be used when the receiver is stationary.

- ii) **Rayleigh – slowly time varying, low Doppler frequency:** This channel model should normally be used for planning portable outdoor and portable indoor reception, as slow channel variations cannot normally be avoided. Even if the receiver itself is stationary there are often other objects in the vicinity of the receiver which move, for example cars, trees or people. At low Doppler frequency the time interleaving in DVB-T2 is less effective, e.g. when the Doppler frequency is $< 1/(\text{interleaving time})$, this will normally result in a higher C/N compared to mobile reception at higher Doppler frequencies. This channel model is often considered to be a worst case for a DVB-T2 receiver.
- iii) **Rayleigh – mobile, high Doppler frequency:** Used for planning mobile reception using external antenna or a handheld device. It should be noted that some DVB-T2 modes are not suitable for mobile reception, in particular the modulation 256-QAM and 32k. A profile particularly designed for mobile reception is DVB-T2-Lite which is described in Annex 5.

2.5.4 C/N for Gaussian channel

The starting point for deriving the final C/N for the identified transmission channel and mode is to determine the ‘final’ C/N for the Gaussian channel (C/N_{Gauss}). The first step is to consult Table 2.9, taken from the ETSI implementation guideline [TS 102 831], to find the value of $C/N_{Gauss-raw}$. Table 2.9 has been derived through computer simulations which to some extent assume ideal conditions not found in practice. Corrections are therefore required to account for these.

TABLE 2.9

**Raw C/N values for a Gaussian Channel
(AWGN channel) (from Table 44 in [TS 102 831])**

Constellation	Code rate	Gaussian Channel $C/N_{Gauss-raw}$ (dB)
QPSK	1/2	1.0
QPSK	3/5	2.3
QPSK	2/3	3.1
QPSK	3/4	4.1
QPSK	4/5	4.7
QPSK	5/6	5.2
16-QAM	1/2	6.0
16-QAM	3/5	7.6
16-QAM	2/3	8.9
16-QAM	3/4	10.0
16-QAM	4/5	10.8
16-QAM	5/6	11.4
64-QAM	1/2	9.9
64-QAM	3/5	12.0
64-QAM	2/3	13.5

TABLE 2.9 (end)

Constellation	Code rate	Gaussian Channel $C/N_{Gauss-raw}$ (dB)
64-QAM	3/4	15.1
64-QAM	4/5	16.1
64-QAM	5/6	16.8
256-QAM	1/2	13.2
256-QAM	3/5	16.1
256-QAM	2/3	17.8
256-QAM	3/4	20.0
256-QAM	4/5	21.3
256-QAM	5/6	22.0

NOTE 1 – Results are given at a BER of 10^{-7} after LDPC, corresponding to approximately 10^{-11} after BCH. Perfect channel-estimation, perfect synchronization, “Genie-Aided” demapping and no phase noise are assumed. Rotated constellations are used, PAPR techniques are not applied.

NOTE 2 – These raw C/N values, taken from Table 44 of [TS 102 831], differ slightly from those assumed in [Nordig2013].

In order to derive the ‘final’ Gaussian channel C/N (C/N_{Gauss}) the following four corrections to $C/N_{Gauss-raw}$ are required:

- A = 0.1 dB assumed additional C/N to achieve the BER= 10^{-7} post LDPC (nominally the appropriate QEF point for DVB-T2). Table 2.9 has been calculated to a higher BER; this factor corrects the calculations.
- B = Correction for pilot boosting according to Table 2.10. The corrections are in line with the DVB-T2 ETSI implementation guideline, but have been rounded to 1 decimal place (DP). The pilots in DVB-T2 (and DVB-T) are boosted, which means that the C/N for the data carriers is reduced. However, in DVB-T2 multiple pilot patterns are available and a different correction is needed for different pilot patterns.
- C = Assumed C/N loss due to real channel estimation, imperfect LDPC decoding and other imperfections not considered part of the back-stop noise. The values to be used are provided in Table 2.10. These values are derived from the Implementation Guideline and also include the manufacturers’ recommended implementation margins (IM).
- D = additional C/N term corresponding to a back-stop noise level at -33 dBc. The main contributions to the back-stop are tuner phase noise and quantization noise in the analogue to digital converters. This back-stop noise term is derived by first calculating the sum of the terms A, B, and C and then checking how much C/N degradation is caused by the -33 dBc receiver back-stop noise level. The term D is identical to this degradation. It should be noted that a change of pilot pattern from, for example PP4 to PP2, which increases C from 1.5 dB to 2.0 dB, will also cause a slight increase in D.

In summary, the procedure for deriving C/N_{Gauss} , the final Gaussian C/N value, is:

$$C/N_{Gauss} = C/N^* + D \text{ (dB)}$$

$$C/N^* = C/N_{Gauss-raw} + A + B + C \text{ (dB)}$$

Table 2.10 provides the correction factors: A (BER Correction), B (Pilot Boost) and C (Real channel estimation).

TABLE 2.10

Averaged *C/N* correction factors (in dB)*

Pilot Pattern	PP1	PP2	PP3	PP4	PP5	PP6	PP7	PP8
A = BER 10^{-7} Correction	0.1	0.1	0.1	0.1	0.1	0.1	0.1	0.1
B = Pilot Boost Correction	0.4	0.4	0.5	0.5	0.5	0.5	0.3	0.4
C = Real Channel Estimation	2.0	2.0	1.5	1.5	1.0	1.0	1.0	1.0

* B has been rounded to 1 decimal place.

Some receivers may, in practice, perform slightly better, or slightly worse, than presented here, with the best receivers being perhaps 0.5-1 dB better, but this is likely to vary with receiver implementation and DVB-T2 mode. If it is thought the majority of receivers in a particular market will indeed perform better than above then the correction factor C could be reduced correspondingly. Making such a reduction would also cause a small change in D, which should be recalculated.

PP8 is a special case and should be considered with some caution. Refer to § 2.7 for more information.

Figure 2.2 and Table 2.11 show D which quantifies the degradation in *C/N* for a back-stop noise level of -33 dBc. It is clear that for higher values of *C/N*, e.g. for high-order modulation schemes and code rates, D can become significant, and should be taken into account.

FIGURE 2.2

Factor D, *C/N* degradation (dB) for a back-stop noise level of -33 dBc

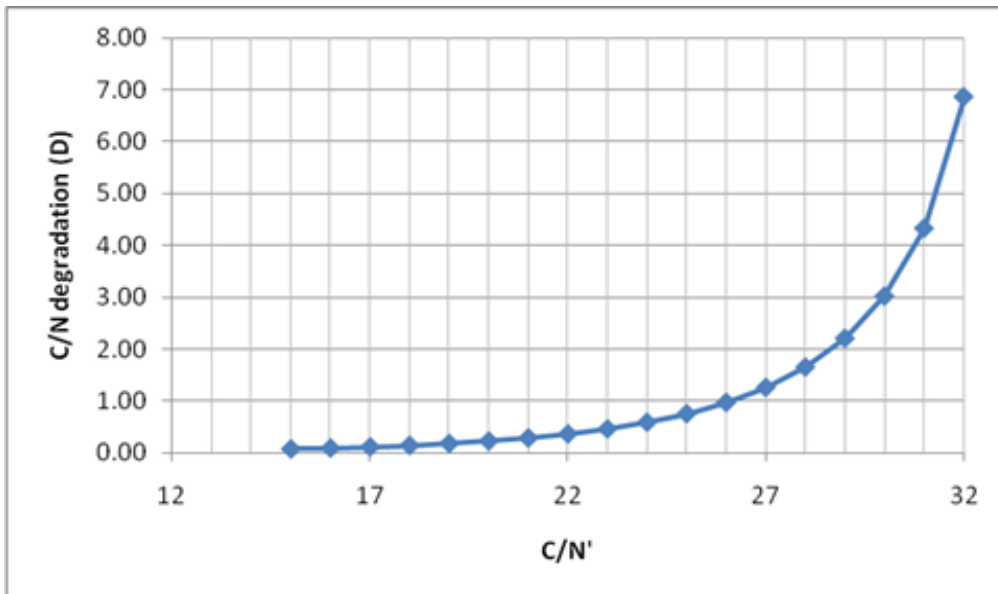

TABLE 2.11

Factor D, *C/N* degradation as table for *C/N* values from 15 to 32

<i>C/N</i> (dB)	15	16	17	18	19	20	21	22	23	24	25	26	27	28	29	30	31	32
D (dB)	0.07	0.09	0.11	0.14	0.18	0.22	0.28	0.36	0.46	0.58	0.75	0.97	1.26	1.65	2.20	3.02	4.33	6.87

As an example, Table 2.12 presents the estimated *C/N* performance for the Gaussian channel for the DVB-T2 variant 256-QAM, 32k, GI=1/8, using normal bandwidth and PP2.

TABLE 2.12

***C/N* QEF valid for DVB-T2 PP2 32k normal BW GI 1/8**

Constellation	Code rate	Gaussian raw value (Table 2.9)	C/N_{Gauss}
QPSK	1/2	1.0	3.5
QPSK	3/5	2.3	4.8
QPSK	2/3	3.1	5.6
QPSK	3/4	4.1	6.6
QPSK	4/5	4.7	7.2
QPSK	5/6	5.2	7.7
16-QAM	1/2	6.0	8.5
16-QAM	3/5	7.6	10.1
16-QAM	2/3	8.9	11.4
16-QAM	3/4	10.0	12.5
16-QAM	4/5	10.8	13.3
16-QAM	5/6	11.4	14.0
64-QAM	1/2	9.9	12.4
64-QAM	3/5	12.0	14.6
64-QAM	2/3	13.5	16.1
64-QAM	3/4	15.1	17.7
64-QAM	4/5	16.1	18.8
64-QAM	5/6	16.8	19.5
256-QAM	1/2	13.2	15.8
256-QAM	3/5	16.1	18.8
256-QAM	2/3	17.8	20.6
256-QAM	3/4	20.0	22.9
256-QAM	4/5	21.3	24.4
256-QAM	5/6	22.0	25.2

2.5.5 *C/N* for Rice and Rayleigh channel

Table 2.9 provides information solely for a Gaussian channel; it does not mention Ricean or Rayleigh channels. However, Table A4.1 in Annex A4, also taken from the ETSI DVB-T2 implementation guideline [TS 102 831], does contain simulation results for these channels. The difference between the simulated results for each channel type and the corresponding simulated Gaussian value can be used to adapt the C/N_{Gauss} , from above, to the Ricean or Rayleigh channel.

The parameters for these simulations are as follows: FFT size 8k, guard interval 1/32, bandwidth 8 MHz normal carrier mode. Rotated constellations were used and PAPR (Peak to Average Power Ratio) techniques were not applied. The simulations assumed ideal conditions, i.e. ideal synchronization and ideal channel estimation.

The results are given at a BER of 10^{-7} after LDPC, corresponding to approximately 10^{-11} after BCH, where an LDPC block length of 64,800 was used. The channel models used for the simulation are described in detail in [TS 102 831, § 14.2].

The difference in required C/N is 0.2 to 0.5 dB when comparing the Gaussian and Ricean channels, and 1.0-3.4 dB when comparing the Gaussian and the Rayleigh values. The larger increases are found for the less robust modes using higher order modulation and codes rates.

Adding this difference to the $C/N_{Gauss-raw}$ from Table 2.9 and following the procedure of § 2.5.4 for the corrections, C/N values for the Ricean and the Rayleigh cases can be derived:

$$C/N^{\circ}_{Rice} = C/N_{Gauss-raw} + DELTA_{Rice} + A + B + C$$

$$C/N_{Rice} = C/N^{\circ}_{Rice} + D$$

$$C/N^{\circ}_{Rayleigh} = C/N_{Gauss-raw} + DELTA_{Rayleigh} + A + B + C$$

$$C/N_{Rayleigh} = C/N^{\circ}_{Rayleigh} + D$$

where DELTA is given in Table 2.13.

TABLE 2.13

Increase DELTA (dB) of C/N for Rice and static Rayleigh channels with regard to Gaussian channel

Constellation	Code rate	DELTA _{Rice} (dB)	DELTA _{Rayleigh} (dB)
QPSK	1/2	0.2	1.0
QPSK	3/5	0.2	1.3
QPSK	2/3	0.3	1.8
QPSK	3/4	0.3	2.1
QPSK	4/5	0.3	2.4
QPSK	5/6	0.4	2.7
16-QAM	1/2	0.2	1.5
16-QAM	3/5	0.2	1.7
16-QAM	2/3	0.2	1.9
16-QAM	3/4	0.4	2.4
16-QAM	4/5	0.4	2.8
16-QAM	5/6	0.4	3.1
64-QAM	1/2	0.3	2.0
64-QAM	3/5	0.3	2.0
64-QAM	2/3	0.3	2.1
64-QAM	3/4	0.3	2.6
64-QAM	4/5	0.5	3.1
64-QAM	5/6	0.4	3.4
256-QAM	1/2	0.4	2.4
256-QAM	3/5	0.2	2.2
256-QAM	2/3	0.3	2.3

TABLE 2.13 (end)

Constellation	Code Rate	DELTA C/N_{Rice} (dB)	DELTA $C/N_{Rayleigh}$ (dB)
256-QAM	3/4	0.3	2.6
256-QAM	4/5	0.4	3.0
256-QAM	5/6	0.4	3.4

Simulations for a LDPC block length of 16,200 give similar results for the difference between Gaussian and Rice or Rayleigh channel, see Implementation Guideline [TS 102 831].

To continue the example of the previous section, Table 2.14 presents the estimated C/N performance for the Ricean and the Rayleigh channel for the DVB-T2 variant 256-QAM, 32k, GI=1/8, using normal bandwidth and PP2.

TABLE 2.14

 C/N QEF valid for DVB-T2 PP2 32k normal BW GI 1/8

Constellation	Code rate	C/N (dB) Gaussian raw values (from Table 2.9)	C/N_{Gauss}	C/N_{Rice}	$C/N_{Rayleigh}$ (static)	0 dB echo channel @ 90% GI
QPSK	1/2	1.0	3.5	3.7	4.5	5.2
QPSK	3/5	2.3	4.8	5.0	6.1	6.9
QPSK	2/3	3.1	5.6	5.9	7.4	8.4
QPSK	3/4	4.1	6.6	6.9	8.7	9.8
QPSK	4/5	4.7	7.2	7.5	9.6	10.9
QPSK	5/6	5.2	7.7	8.1	10.4	12.0
16-QAM	1/2	6.0	8.5	8.7	10.0	10.7
16-QAM	3/5	7.6	10.1	10.3	11.8	12.7
16-QAM	2/3	8.9	11.4	11.6	13.3	14.4
16-QAM	3/4	10.0	12.5	12.9	15.0	16.3
16-QAM	4/5	10.8	13.3	13.8	16.2	17.8
16-QAM	5/6	11.4	14.0	14.5	17.1	19.1
64-QAM	1/2	9.9	12.4	12.7	14.5	15.4
64-QAM	3/5	12.0	14.6	14.9	16.9	17.7
64-QAM	2/3	13.5	16.1	16.4	18.2	19.6
64-QAM	3/4	15.1	17.7	18.0	20.4	22.0
64-QAM	4/5	16.1	18.8	19.3	22.0	24.0
64-QAM	5/6	16.8	19.5	19.9	23.1	25.6
256-QAM	1/2	13.2	15.8	16.2	18.3	19.4
256-QAM	3/5	16.1	18.8	19.0	21.1	22.5
256-QAM	2/3	17.87	20.6	20.9	23.0	24.9
256-QAM	3/4	20.0	22.9	23.2	25.9	28.0
256-QAM	4/5	21.3	24.5	24.8	28.0	30.9
256-QAM	5/6	22.0	25.2	25.6	29.5	33.6

For information, Table 2.14 also contains expected 0 dB echo performance at 90% of the guard interval length. These values are calculated using the same principle as previously described, by adding the difference between the C/N Gaussian and simulated C/N 0 dB from Table A4.1 in Annex 4 to the previously derived C/N for the Gaussian channel.

However, additional code rate dependent degradation needs to be added in the 0 dB echo case. This degradation factor is given in Table 2.15. The C/N values given in Table 2.14 include the additional degradation factor.

TABLE 2.15

Additional code rate dependent C/N degradation for 0 dB echo profile

Code rate	1/2	3/5	2/3	3/4	4/5	5/6
Additional degradation (dB)	1.0	1.2	1.4	1.6	1.8	2.0

The 0 dB echoes profile is mainly used for testing of receiver performance, since it is considered as a worst case. However, strong echoes or echoes where the echo level is the same as the wanted (0 dB echoes) can occur in practice, most commonly in SFNs.

In such cases, the receiver would require an additional margin up to the limit set out in Table 2.15, depending on the echo delay and magnitude. The worst condition occurs when two signals from two transmitters arrive with the same amplitude at the receiver. In this case, the channel frequency response of the received signal presents a periodic fading pattern which is frequency dependent on the inverse of the relative delay between echoes. The impact on the receiver will depend strongly on the pilot pattern and on the channel estimation algorithm [Po2005].

From experience with DVB-T and DVB-H it can be expected that the C/N for DVB-T2 in a time-variant Rayleigh channel would be higher than those for a static Rayleigh channel. But, depending upon the receiver performance, variations can be expected. For low Doppler frequencies, significantly higher C/N values can be expected since the time interleaving in DVB-T2 is not effective at low Doppler frequencies $< 1/(\text{interleaving time})$.

Since there are still no receivers available which are particularly optimized for portable and mobile reception, this Report does not give a methodology for the calculation of C/N values for a time-variant Rayleigh channel which is the relevant transmission channel for mobile reception.

Annex 4 compares the results obtained from applying this methodology to measurements of a restricted sample of DVB T2 receivers. This comparison indicates that the methodology derived C/N ratios of this section are perhaps conservative with respect to certain DVB T2 modes and receiving environments. There is a tendency that for the Gaussian channel the calculated C/N are about 1 to 2 dB higher than the measured values from laboratory and field trials. For the Ricean channel the calculated C/N are higher by 0 - 1 dB than the measured figures, and for the Rayleigh channel the calculated C/N fit quite well with the measured C/N . If further measurements confirm these findings a refinement of the approach may be considered.

The few results reported in Annex 4 on time-variant Rayleigh channels indicate an increase of several dBs for the C/N values compared to the static Rayleigh case which may be applied to portable reception.

Moreover, the results of [Nord2012] reported in Annex 4 show that for mobile reception C/N values are very sensitive to the chosen FFT mode. This dependency is not taken into account in the methodology proposed in § 2.5. It has to be extended in a future version of this Report when also C/N figures for mobile reception will be proposed.

2.6 Rotated constellation

2.6.1 Concept

In DVB-T2 a performance improvement with regard to DVB-T is achieved by treating the constellation diagram of the channel symbols in a more flexible way. A rotation of the constellation diagram is applied which yields an improvement. Here, the description of this approach follows the presentation given by [ND2007, ND2008]. Also the results quoted in § 2.6.6 are taken from these references; they are theoretical results assuming ideal receiver behaviour.

2.6.2 Constellation diagram

In DVB-T2 modulation, an information frame is encoded via a binary outer FEC code, then processed by a bit interleaver and the resulting sequence is mapped to a succession of complex channel symbols. Such a channel symbol is composed of an in-phase (I) and a quadrature (Q) component, represented in a constellation diagram as shown in Fig. 2.3. A symbol carries m bits according to the chosen 2^m -ary constellation characteristics. In QPSK a symbol carries two bits, in 16-QAM it carries 4 bits, in 64-QAM it carries 6 bits, etc.

FIGURE 2.3
Constellation diagram for 16-QAM modulation
(Figure taken from [ND2008])

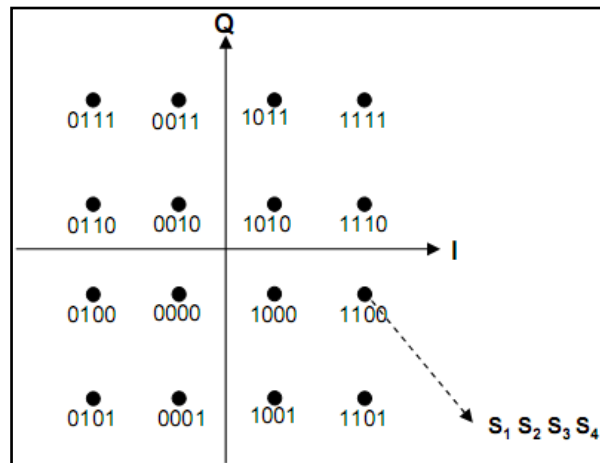

There are various ways of attributing the bits to the symbols. Best results are achieved if only one bit is changed when going from one symbol to the next closest symbol. In this way only one bit is mistaken when a symbol mismatch occurs with the next closest symbol. This coding is called Gray mapping. Figure 2.3 shows a Gray mapping constellation.

2.6.3 Rotation of the constellation diagram

Gray mapping implies an independence of I and Q components of the symbol. As a consequence, all constellation points need both I and Q components to be identified. I contains no information about Q and vice versa. One way of avoiding this independence is to rotate the constellation diagram, as shown in Fig. 2.4. Now each single m -bit has an individual I and Q component.

FIGURE 2.4
Rotated constellation diagram for 16-QAM modulation
(from [TS 102 831])

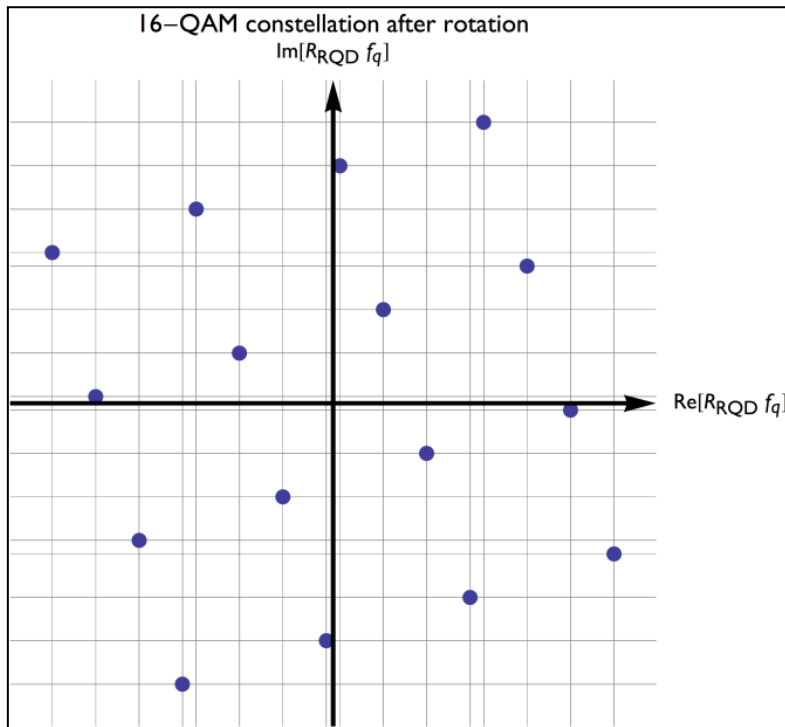

2.6.4 Rotation angle

In order to determine the optimal rotation angle various aspects have to be considered. Generally, the projection of the constellation points on one axis should have equal distance to gain the best performance. This is best achieved with the rotation angles given in Table 2.16.

TABLE 2.16

Values of the rotation angle

Constellation	Rotation angle (degrees)
QPSK	29.0
16-QAM	16.8
64-QAM	8.6
256-QAM	3.6

2.6.5 Time delay between I and Q

Rotated constellations do not, however, give a remarkable improvement should I and Q suffer from an identical loss in a fading channel. To overcome this difficulty the so-called Q-delay is introduced. With this delay the Q value is not transmitted in the same cell as the I value, but it is shifted (delayed) to a different cell. Frequency and time interleaving schemes which follow after this modulator stage ensure that the corresponding I and Q values are transmitted in a well separated way in time and frequency. Figure 2.5 illustrates the process.

FIGURE 2.5

Structure of bit interleaved coded modulation with rotated-QAM mapper and delay

(Figure taken from [F2010])

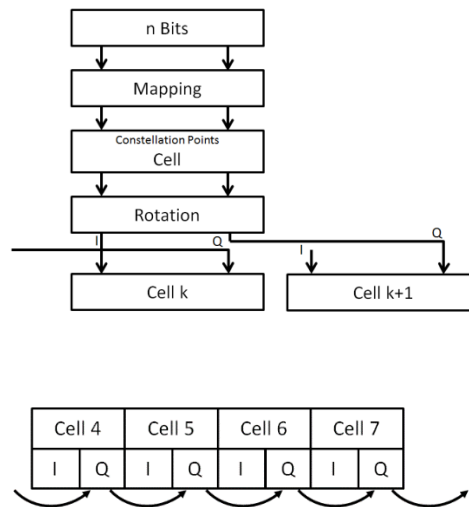

A cell is the result of mapping a later carrier. In contrast to DVB-T, mapping is not carried out after all interleaving processes but relatively early, after the error protection and after the bit interleaver. However, this is still followed by the cell interleaver, the time interleaver and the frequency interleaver which is the reason why the mapping result cannot yet be allocated to a carrier and why the term “cell” was introduced. A cell is, therefore, a complex number consisting of an I-component and a Q-component, i.e. a real part and an imaginary part. For more details see [F2010].

2.6.6 Improvement of performance

For a 16-QAM modulation, code rate 4/5 and 64800-bit frames, simulations indicate that the application of a rotated constellation diagram provides an improvement of performance of about 0.5 dB for a flat fading Rayleigh channel without erasures, relevant for an MFN. This is not a remarkable improvement. However, for a flat fading Rayleigh channel with erasures (15% assumed), relevant for SFN, an improvement of about 6 dB is predicted, which would be remarkable, see Table 2.14.

This 6 dB result is based on a simulation that uses ideal identification of erasures, which allows the decoding/demapping algorithms to make the maximum coding gain. In a real receiver, identifying erasures is extremely difficult because they are affected by noise, so in practice these gains are not achievable.

There exists an additional technique, iterative demapping, which may improve the performance by another 0.4 dB for a flat fading Rayleigh channel without erasures and 1.2 dB for a flat fading Rayleigh channel with erasures, see Table 2.17.

TABLE 2.17

Improvement of performance with rotated constellation diagram, time delay and iterative demapping for 16-QAM, code rate 4/5, 64800-bit frames

Channel	Rotated constellation diagram and time delay	Iterative demapping	Sum
Flat fading Rayleigh channel without erasures (MFN case)	0.5 dB	0.4 dB	0.9 dB
Flat fading Rayleigh channel with erasures (15%) (SFN case)	6.0 dB	1.2 dB	7.2 dB

For a 64-QAM modulation, code rate 9/10, 64800-bit rate, the improvement would amount to about 1.2 dB for a flat fading Rayleigh channel without erasures, to about 3.4 dB for 5% erasures, and the improvement vanishes if the occurrence of erasure events exceeds the coding rate, e.g. for 15% erasures there is no improvement at all since the chosen modulation scheme is too vulnerable.

Iterative demapping is quite complex to implement, which is the reason why it is not found in receivers that are presently available.

Finally, the benefit of the rotated constellation concept for network planning is still to be assessed by laboratory and field tests.

2.7 Scattered pilot patterns

2.7.1 Principle of scattered pilot pattern

Pilots are carriers which do not contain net information but serve for transmission purposes such as channel estimation, equalization, Common-Phase-Error correction and synchronization. Of the different kinds of pilots such as continual, scattered, P2 and frame-closing pilots, only the scattered pilots can be changed, so only they are considered further here.

Scattered pilots are used by the DVB-T2 receiver to make measurements of the channel and to estimate the channel response for every OFDM cell so that distortions in the received signal may be corrected to some extent. The measurements, and hence pilot density, need to be sufficiently high so that they can follow channel fluctuations as a function of both frequency and time.

In DVB-T2, eight different pilot patterns are available, PP1 to PP8. As certain patterns are more suited to particular channel types than others, the range in pilot patterns gives the network planner more freedom to match the transmission mode and pilot pattern to the intended transmission channel or payload requirement. An overview of the modes is provided in Table 2.18. When determining which pilot pattern to use the following main factors should be considered:

Doppler performance: Patterns with a rapid repeat cycle (i.e. $D_y = 2$) in which the pilots repeat every second OFDM symbol, provide the better Doppler performance. For networks where Doppler is a dominant factor, such as mobile and portable, patterns 2, 4 or 6 should be considered as they have the smallest D_y value.

Capacity: The least dense patterns, i.e. those with the greatest distance between pilots, in both time (D_y) and frequency (D_x), provide the greatest payload as fewer carriers are used for pilots, and subsequently more are available to carry data. The Scattered Pilots Overhead row in Table 2.18 quantifies the overhead due to pilots, which can be significant. Although it may be tempting to select the least dense pattern to maximize payload, performance will be traded-off in other areas, and that should be considered.

FFT Size and Guard Interval: Only a subset of pilot patterns is permitted for every FFT size and Guard Interval combination – these are shown in Table 2.19. The Table is valid only for SISO (single input single output) of DVB-T2. A different Table applies to MISO (multiple input single output) which is described in detail in § 4.3.

C/N: Section 2.5 presents a method for determining the *C/N* for different transmission modes. In that section it is shown that the *C/N* is dependent on the pilot pattern and that the denser patterns require a higher *C/N* than those with a lower density. If the *C/N* is a dominant factor then lower density patterns, such as PP6 and PP7 could be considered, though the benefit is marginal.

The small distance (*D_x*) of the pilots in PP1 proves this pattern as most robust against inter-symbol interference, whereas PP6 and PP7 are most vulnerable to it.

PP8 – Receiver Capability: Pilot pattern 8 requires the receiver to employ a channel equalization strategy that is fundamentally different to the others – PP8 channel estimation is based on the data rather than the pilots. No receivers are known to have incorporated this mode, largely due to the additional complexity required in the receiver. Therefore before settling on this pattern, receivers intended for the service should be confirmed to support it. Furthermore PP8 has some limitations over the others that should be considered. PLPs are not supported in PP8, and time interleaving should not be used – the latter means that the vastly improved impulse resilience of DVB-T2, a significantly important benefit, cannot be realized. More detailed information regarding this mode, its benefits and limitations, can be found in §§ 5.4 and 10.3.2.3.5.4 and 16.2.4.5.6 of the implementation guidelines [TS 102 831], should it be required.

Table 2.18 shows the different pilot patterns that are available. It summarizes the pattern density in both time and frequency and shows the overhead introduced by a given pattern.

TABLE 2.18

Comparison of Scattered Pilot patterns (from [TS 102 831])

	PP1	PP2	PP3	PP4	PP5	PP6	PP7	PP8	Interpretation
D_x	3	6	6	12	12	24	24	6	Separation of pilot-bearing carriers
D_y	4	2	4	2	4	2	4	16	Length of sequence in symbols
1/D_xD_y	8.33%	8.33%	4.17%	4.17%	2.08%	2.08%	1.04%	1.04%	Scattered pilots overhead

Table 2.19 shows the allowed pilot patterns for a given combination of FFT size and guard interval.

TABLE 2.19

Scattered pilot pattern to be used for each allowed combination of FFT size and guard interval in SISO mode (from [EN 302 755])

FFT size	Guard Interval						
	1/128	1/32	1/16	19/256	1/8	19/128	1/4
32k	PP7	PP4 PP6	PP2 PP8 PP4	PP2 PP8 PP4	PP2 PP8	PP2 PP8	<i>n/a</i>
16k	PP7	PP7 PP4 PP6	PP2 PP8 PP4 PP5	PP2 PP8 PP4 PP5	PP2 PP3 PP8	PP2 PP3 PP8	PP1 PP8
8k	PP7	PP7 PP4	PP8 PP4 PP5	PP8 PP4 PP5	PP2 PP3 PP8	PP2 PP3 PP8	PP1 PP8
4k, 2k	<i>n/a</i>	PP7 PP4	PP4 PP5	<i>n/a</i>	PP2 PP3	<i>n/a</i>	PP1
1k	<i>n/a</i>	<i>n/a</i>	PP4 PP5	<i>n/a</i>	PP2 PP3	<i>n/a</i>	PP1

A comprehensive overview of the various combinations of systems variants and pilot patterns and the corresponding data rates can be found in Annex 2.

2.7.2 Sample pilot pattern choices

The following pilot patterns would be appropriate in the common scenarios below.

Rooftop reception: Rooftop reception with a directional outdoor antenna system usually exhibits a low Doppler environment with few significant reflections. As such PP7, a low overhead pattern that is less robust to Doppler can be adopted to maximize capacity.

Mobile reception: In a mobile channel where a fast change of channel characteristics is encountered, more pilots are better for channel estimation. In addition, temporal resolution seems to be more critical than frequency resolution. Therefore, pilot patterns PP2, then PP4, then PP6 would be the options.

Portable reception: In a portable reception where the channel characteristics do not change that fast it can be better to have less (reduce overhead) but boosted pilots, which means PP3 or PP4 would be favoured.

Large area SFNs: In networks where large area SFNs are necessary, a longer guard interval would be required, such as 1/8, or possibly greater. In these cases only patterns 1, 2 or 3 would be available (Table 2.19). It is apparent that there is some trade-off between Doppler performance and guard interval size. Pilot pattern 2 may provide the best compromise between the two.

To aid the reader in visualising and understanding the pilot pattern structure, four schematic diagrams have been reproduced from Annex K of the DVB-T2 specification [EN 302 755 V1.3.1]. The first two diagrams clearly show, for PP1 and PP7, the positioning of the scattered pilots in both the time and frequency directions in a traditional SISO network.

The final two diagrams show the same pilot patterns as they would be implemented in a MISO network for comparison.

FIGURE 2.6

Pilot pattern 1 – SISO (from [EN 302 755 V1.3.1])

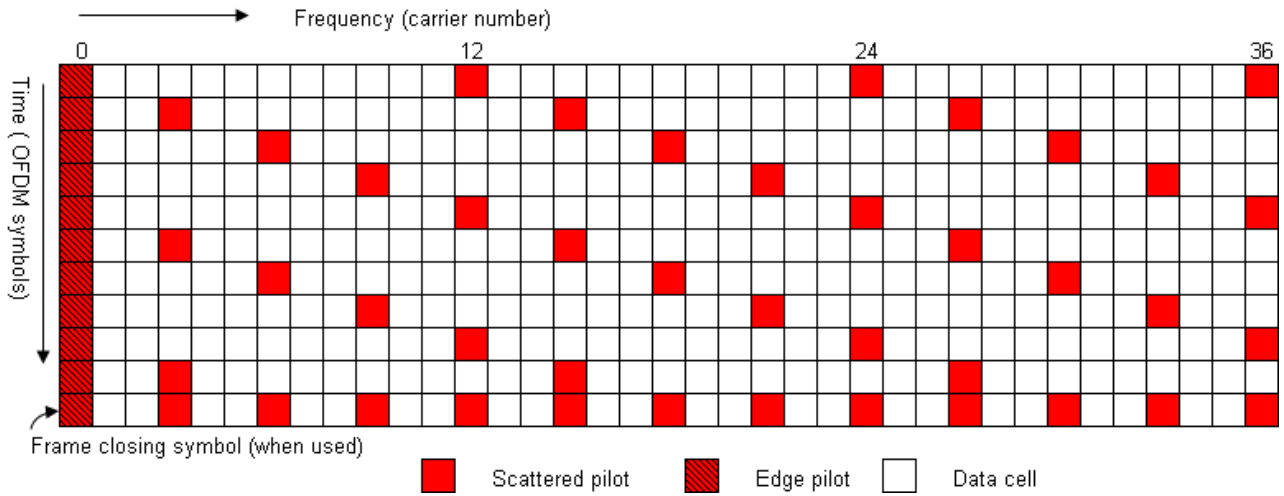

FIGURE 2.7

Pilot pattern 7 – SISO (from [EN 302 755 V1.3.1])

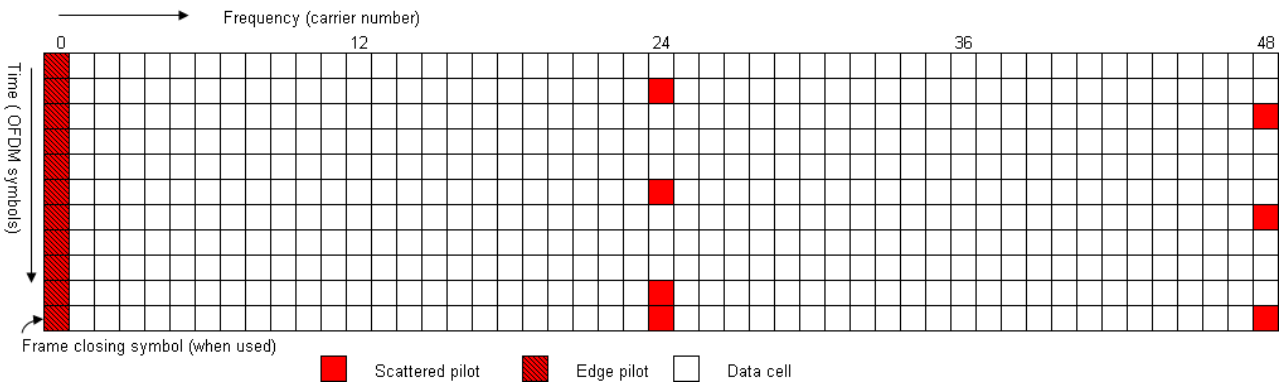

FIGURE 2.8

Pilot pattern 1 – MISO (from [EN 302 755 V1.3.1])

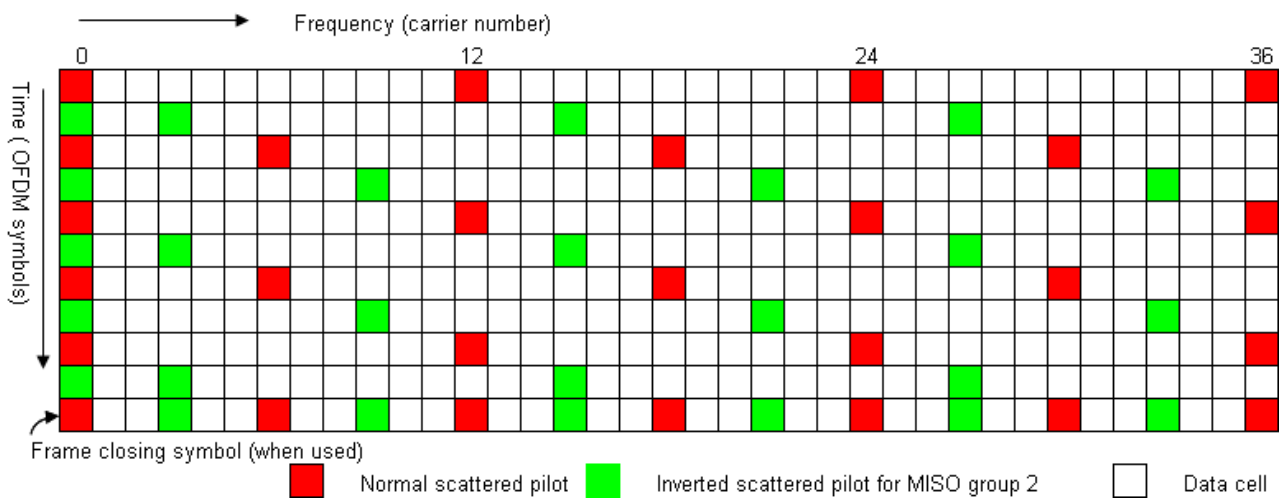
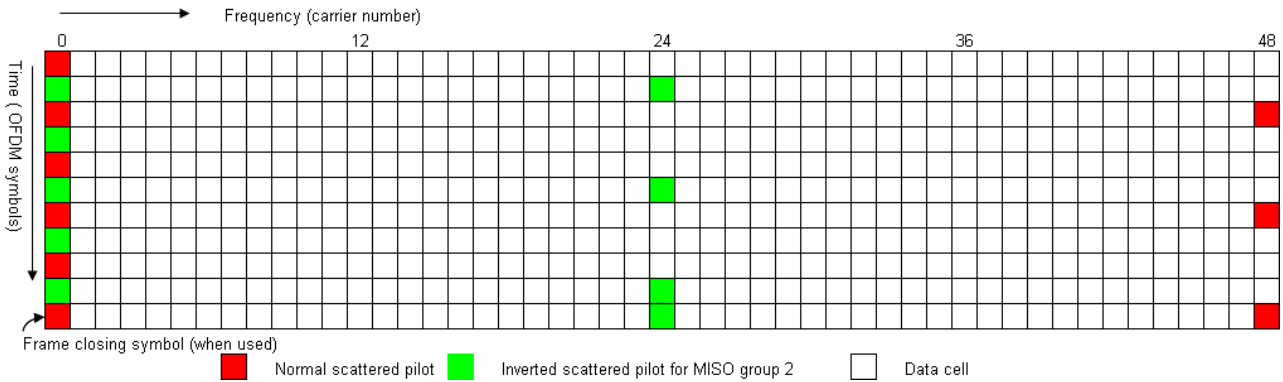

FIGURE 2.9
Pilot pattern 7 – MISO (from [EN 302 755 V1.3.1])



2.8 Time interleaving

A further important improvement of DVB-T2 as compared to DVB-T is the introduction of time interleaving which significantly increases the robustness of the system against impulsive noise and time selective fading. The interleaving time may range from a few milliseconds up to some seconds. A typical value is 70 ms.

Time interleaving also improves the Doppler behaviour of the system. Figure 2.10 compares the required C/N for DVB-T and DVB-T2 as a function of the velocity of the mobile receiver. The simulation is made for a 16-QAM modulation at 600 MHz and a time interleaving depth for DVB-T2 of 100 ms. The limit for the maximum velocity is shifted from 90 km/h for DVB-T to 125 km/h for DVB-T2. The Figure also shows the performance of DVB-T2 at 200 MHz, 500 MHz and 800 MHz.

FIGURE 2.10
Required C/N for DVB-T and DVB-T2 as a function of the velocity of the mobile receiver, 8k FFT (from [AFM2010])

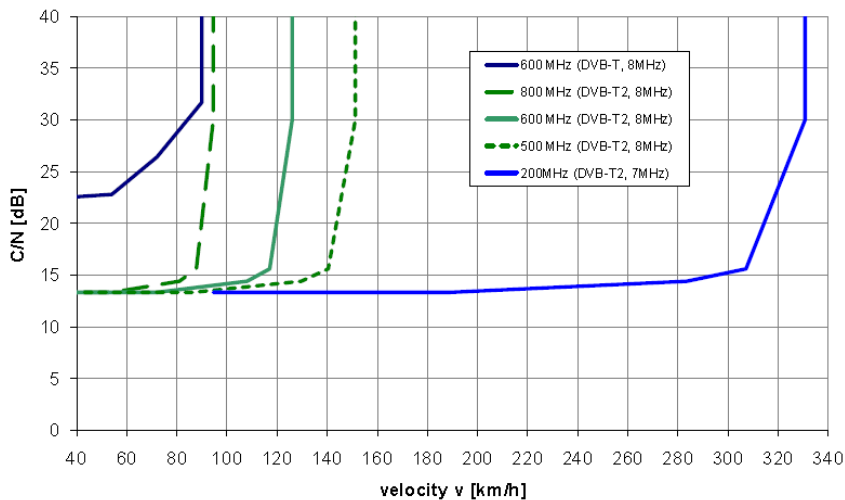

It has, however, to be taken into account that there is a trade-off between a large time interleaving depth (if >250 ms) and the time of receiver lock and recovery which also is a criterion of reception quality.

2.9 Bandwidth extension

DVB-T2 allows for the extension of the number of used carriers for the 8k, 16k and 32k mode while at the same time keeping the bandwidth limits of the RF channel. This mode is called the Extended Carrier Mode. Figure 2.11 shows the spectral density of the extended carrier mode for the various FFT modes.

FIGURE 2.11
Theoretical DVB-T2 signal spectrum for guard interval fraction 1/8
(for 8 MHz channels and with extended carrier mode for 8k, 16k and 32k)
(from [EN 302 755])

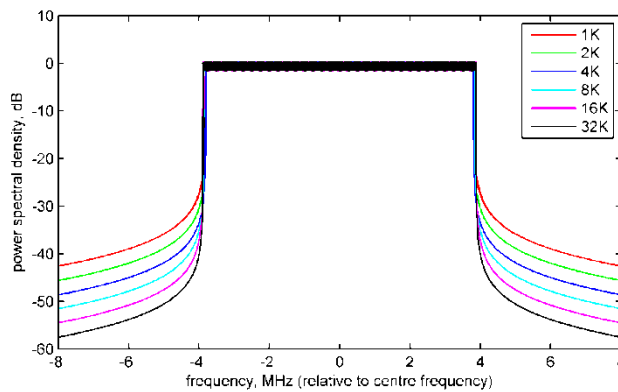
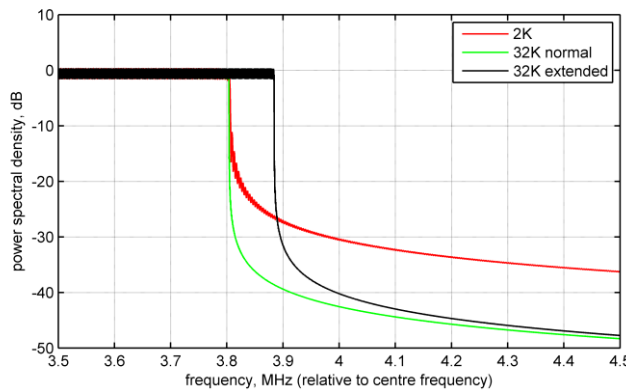

Figure 2.12 compares the normal and the extended carrier mode for the 32k FFT.

FIGURE 2.12
Detail of theoretical DVB-T2 spectrum for guard-interval fraction 1/8 (for 8 MHz channels)
(from [EN 302 755])



Because of its higher number of usable carriers the extended carrier mode has an increased data capacity as the normal carrier mode. Table 2.20 gives the gain of the extended carrier mode for the different FFT modes.

TABLE 2.20

Gain of data capacity for the extended carrier mode

FFT	Carrier mode		
	Normal	Extended	
Size	Carriers	Carriers	Gain
1k	853	–	0.00%
2k	1705	–	0.00%
4k	3409	–	0.00%
8k	6817	6913	1.41%
16k	13633	13921	2.11%
32k	27265	27841	2.11%

2.10 Phase noise

Phase noise impairs the DVB-T2 performance by two mechanisms: common phase error (CPE) and inter-carrier interference (ICI). CPE produces a common rotation of all the constellations in an OFDM symbol, and since it is common to all carriers it can be compensated for and therefore introduces no additional degradation. ICI, a form of cross-talk between carriers, cannot be compensated for and therefore produces additional noise.

ICI increases, in general, with larger FFT size, i.e. smaller carrier spacing. However, in the implementation guideline [TS 102 831] it is stated that the experience from DVB-T shows that the difference between 2k and 8k modes is small. Based on this experience and based on software simulations it is expected that 16k and 32k modes will not be significantly worse than 2k and 8k. In the meantime this has been confirmed by laboratory tests.

2.11 Choice of system parameters**2.11.1 Choice of FFT size**

The results of choosing a certain FFT size are well known: an increased FFT size will give a greater delay tolerance for the same fractional guard interval, allowing larger SFNs to be constructed. Alternatively, a larger FFT size allows the same delay tolerance to be achieved with a smaller overhead due to the guard interval.

A larger FFT size implies a longer symbol duration, which means that the guard interval fraction is smaller for a given guard interval duration in time (see, for example, Fig. 2.12). This reduction in overhead leads to an increase in throughput ranging from 2.3% to 17.6%.

FIGURE 2.12

Guard interval overhead reduction with larger FFT size

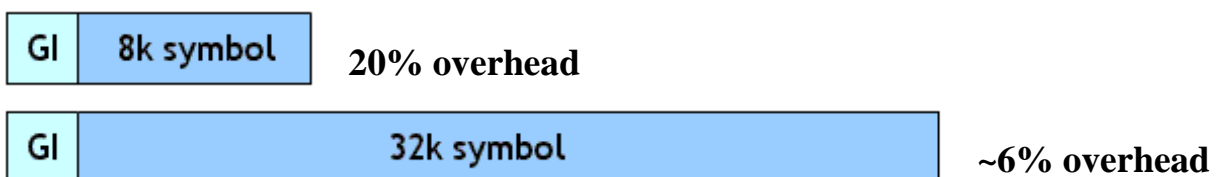

For mobile reception in UHF Band IV/V, or higher bands, smaller FFT sizes should be used as they offer better Doppler performance. The 1k FFT mode which offers the highest Doppler performance is intended primarily for operation in the L-band (about 1.5 GHz), or higher, using a nominal occupied bandwidth of 1.7 MHz. Given that the fundamental sampling rate is lower, the carrier spacing will be correspondingly smaller than it would be in an 8 MHz channel.

For delivering high-bit-rate services to fixed rooftop antennas, in VHF or UHF, the 32k FFT mode is more appropriate. In this situation the time variations in the channel are minimized, and 32k offers the very highest bit rates achievable using DVB-T2.

For a given FFT size, constellation and code rate, the Doppler performance is roughly proportional to the RF bandwidth (halving the bandwidth will halve the carrier spacing resulting in half the Doppler performance) and inversely proportional to the RF frequency and therefore higher frequencies are more vulnerable to fast time-varying channels, having poorer Doppler performance.

Therefore, roughly the same Doppler performance should be expected for mobile applications in VHF Band III (about 200 MHz) using the 32k mode as when using the 8k mode at 800 MHz, so 32k may be an option even at VHF using 7 MHz RF bandwidth. The performance in time-varying channels can also be affected by the choice of pilot pattern.

On the other hand, increasing the FFT size would proportionally decrease the Doppler performance of the system.

2.11.2 Selection of DVB-T2 mode for SFNs

When selecting a transmission mode for DVB-T2 the actual choice (as in the case of DVB-T) depends upon the network requirements. As always a trade-off between capacity and robustness needs to be made.

One approach for selecting a mode for SFN operation would be to select the length of the guard interval according to the physical size of the SFN or the SFN's intra transmitter separation distances, noting of course that it may be possible to have larger transmitter separations than the guard interval depending on practical considerations such as terrain, propagation and system robustness, etc. Additionally, optimization of coverage by modification of antenna diagrams, transmitter powers, antenna heights, transmitter timing, etc. may allow larger transmitter distances in the SFN than the guard interval. However, in such cases, detailed coverage simulations need to be made.

Together with the selection of the length of the guard interval, the guard interval fraction also needs determination. The GI fraction involves consideration of the FFT size which is related to the reception scenario: fixed rooftop, portable or mobile reception. In the case of fixed rooftop reception it would seem desirable to use 32k or 16k FFT as a larger FFT size would reduce the GI fraction and increase the available capacity. For portable and mobile reception a lower FFT size such as 16k, 8k or even 4k may need to be considered, in particular for mobile reception when Doppler is a limitation.

The choice of modulation determines the bit rate (capacity), but it also has a large impact upon the robustness of the system; higher order modulation schemes that offer more capacity are more fragile. It should however be noted that due to the more efficient channel coding, rotated constellation, etc. used in DVB-T2, compared with DVB-T, 256-QAM will require C/N values in the same order of magnitude as those previously required for 64-QAM, that is, values in the order of 17-20 dB depending on the code rate used, see § 2.5.

Increased system robustness will also have a large impact upon SFN performance since a lower required C/N will reduce the susceptibility for SFN self-interference. DVB-T2 will give the possibility to provide much higher data rates than current DVB-T networks designed for portable or mobile reception.

Additionally, there are several Scattered Pilot Patterns (PP) available in DVB-T2, PP1 to PP8. They are described in more detail in § 2.7. The choice of pilot patterns will determine the performance for delayed signals arriving outside the guard interval as given by the Nyquist limit. Exceeding this Nyquist limit means that channel equalization is incorrect even if the fraction of inter-symbol interference (ISI) is small.

3 Receiver properties, sharing and compatibility, network planning parameters

For frequency and network planning of DVB-T2 knowledge of receiver properties, sharing and compatibility criteria and network planning parameters is required. Many of the network planning parameters and methods are well known from DVB-T and DVB-H planning. They comprise definition of coverage and reception modes, method of calculation of minimum median equivalent field strengths, treatment of antenna gain, feeder loss, man-made noise and building penetration loss, or the definition of location percentage requirements. All these are given in Annex 1.

In this section, aspects particular to DVB-T2 are described such as minimum receiver input levels, signal levels for planning, or protection ratios.

3.1 Minimum receiver signal input levels

To illustrate how the C/N ratio influences the minimum signal input level for the receiver, the latter has been calculated for five representative C/N ratios. They are given in Table 3.1. For other values simple linear interpolation can be applied.

The receiver noise figure has been chosen as 6 dB for the frequency Bands III, IV and V. Previously a number of different noise figure values ranging from 5-7 dB has been used. The EBU planning guideline for DVB-T [BPN005] suggests the value 7 dB. However, it is believed that improvements in digital receiver design will justify this small modification. Using the same receiver noise figure for all frequency bands will mean that the minimum receiver input signal level is independent of the transmitter frequency. If other noise figures are used in practice, the minimum receiver input signal level will change correspondingly by the same amount.

The minimum receiver input signal levels calculated here are used in § 3.3 to derive the minimum power flux-densities and corresponding minimum median equivalent field strength values for various frequency bands and reception modes.

Definitions:

- B : Receiver noise bandwidth (Hz)
- C/N : RF required by the system (dB)
- F : Receiver noise figure (dB)
- P_n : Receiver noise input power (dBW)
- $P_{s\ min}$: Minimum receiver signal input power (dBW)
- $U_{s\ min}$: Minimum equivalent receiver input voltage into Z_i (dB μ V)
- Z_i : Receiver input impedance (75 Ω)

Constants:

- k : Boltzmann's Constant = $1.38 \cdot 10^{-23}$ Ws/K
- T_0 : Absolute temperature = 290 K

Formulas used:

$$P_n \text{ (dBW)} = F + 10 \log (k \cdot T_0 \cdot B)$$

$$P_{s \text{ min}} \text{ (dBW)} = P_n + C/N$$

$$U_{s \text{ min}} \text{ (dB}\mu\text{V)} = P_{s \text{ min}} + 120 + 10 \log (Z_i)$$

TABLE 3.1

Minimum required input signal levels for 8 MHz versions and different C/N values

Frequency bands III, IV, V – 8 MHz channels					
Normal carrier mode: 1k, 2k, 4k, 8k, 16k, 32k modes					
Equivalent noise bandwidth B (Hz)	7.61*10 ⁶	7.61*10 ⁶	7.61*10 ⁶	7.61*10 ⁶	7.61*10 ⁶
Receiver noise figure F (dB)	6	6	6	6	6
Receiver noise input power P_n (dBW)	-129.2	-129.2	-129.2	-129.2	-129.2
RF signal/noise ratio C/N (dB)	8.0	12.0	16.0	20.0	24.0
Min. receiver signal input power $P_{s \text{ min}}$ (dBW)	-121.2	-117.2	-113.2	-109.2	-105.2
Min. equivalent receiver input voltage, $U_{s \text{ min}}$ (dBμV) 75 Ω	17.5	21.5	25.5	29.5	33.5

NOTE – This Table provides a derivation of minimum required signal levels; § 3.3 provides information on the minimum median values of signal levels required in practical situations.

For the extended carrier mode 8k (with an equivalent noise bandwidth of 7.71 MHz) and the extended carrier modes 16k, 32k (with an equivalent noise bandwidth of 7.77 MHz), the figures of required signal power and voltage for the normal carrier modes should be used because the small increase in the equivalent noise bandwidth has a negligible impact on the final value.

For other channel bandwidths B' (1.7, 5, 6, 7 or 10 MHz), the figures of minimum required signal power and voltage could be derived from Table 3.1 by adding the correction factor $10 \log(B'/B)$.

3.2 Signal levels for planning

In § 3.1 the minimum signal levels to overcome noise are given as the minimum receiver input power and the corresponding minimum equivalent receiver input voltage. No account is taken of any propagation effect. However, it is necessary to consider these effects when considering reception in a practical environment.

In defining coverage, it is indicated that due to the very rapid transition from near perfect to no reception at all, it is necessary that the minimum required signal level is achieved at a high percentage of locations. These percentages have been set at 95% for “good” and 70% for “acceptable” portable reception. For mobile reception the percentages defined were 99% and 90%, respectively, see Annex 1.

In § 3.3 minimum median power flux-densities and equivalent field strengths are presented which are needed for practical planning considerations. Six different reception modes are described which are listed in Table 3.2.

TABLE 3.2

Reception modes, example DVB-T2 variants, C/N values

Reception mode	Example DVB-T2 variant	C/N (dB)
Fixed reception	256-QAM, FEC 2/3, 32k, PP7	19.7
Portable outdoor reception/urban (Class A)	64-QAM, FEC 2/3, 32k, PP4	17.8
Portable indoor reception/urban (Class B)	64-QAM, FEC 2/3, 16k, PP1	18.2
Mobile reception/rural	16-QAM, FEC 1/2, 8k, PP1	10.0
Handheld portable outdoor reception (Class H-A)	16-QAM, FEC 1/2, 16k, PP3	9.6
Handheld mobile reception (Class H-D) (i.e. terminals are used within a moving vehicle)	16-QAM, FEC 1/2, 8k, PP2	10.0

The calculations are performed for two frequencies representing Band III (200 MHz) and Bands IV and V (650 MHz) and a bandwidth of 7 MHz in Band III and 8 MHz in Bands IV and V. For Band III the “mobile/rural” reception mode is calculated for the 1.7 MHz bandwidth and the “handheld class H-D” reception mode is calculated for both 1.7 MHz and 7 MHz bandwidth. Values for other frequencies or bandwidths may be calculated as described in § 3.1 and Annex 1.

Suitable DVB-T2 variants are chosen for the reception modes, see Table 3.2. They are to be understood as examples for the respective reception modes, since the large number of DVB-T2 system variants always allows for a choice out of several possible variants. In § 5 a more detailed treatment of possible system variants for the various reception modes and implementation scenarios is given.

In order to calculate the minimum median power flux-densities and equivalent field strengths the C/N figures for the different DVB-T2 variants are needed. They are given in the third column of Table 3.2 and calculated as described in § 2.5.

The values for other reception modes or other DVB-T2 variants may be derived from these six representative cases. More details are given in Annex 1.

3.3 Examples of signal levels for planning

The following § 3.3.1 and § 3.3.2 give the details of the calculation for the cases listed in § 3.2.

The DVB-T2 variants indicated in the tables are examples for a possible choice of the variant. For each reception mode there are several DVB-T2 variants available with their respective bit rates. In addition, the choice of the guard interval affects the bit rate but does not change the required C/N . Therefore, in the tables, for the available net bit rate a range is given. Not all guard interval lengths are available for the chosen pilot pattern. If the latter is changed also the C/N may slightly change.

In the tables, the reception height is 10 m above ground level (a.g.l.) for fixed reception and 1.5 m a.g.l. for the other reception modes.

3.3.1 DVB-T2 in Band III

			Fixed	Portable outdoor/urban	Portable indoor/urban	Mobile/rural	Handheld portable outdoor	Handheld mobile Class H-D/ integrated antenna	Handheld mobile Class H-D/ integrated antenna
Frequency	Freq	MHz	200	200	200	200	200	200	200
Minimum C/N required by system	C/N	dB	19.7	17.8	18.2	10.0	9.6	10.0	10.0
System variant (example)			256-QAM FEC 2/3, 32k, PP7 Normal	64-QAM FEC 2/3, 32k, PP4 Normal	64-QAM FEC 2/3, 16k, PP1 Normal	16-QAM FEC 1/2, 8k, PP1 Normal	16-QAM FEC 1/2, 16k, PP3 Normal	16-QAM FEC 1/2, 8k, PP2 Normal	16-QAM FEC 1/2, 8k, PP2 Normal
Bit rate (indicative values)		Mbit/s	30-35	22-25	19-24	2.2-2.8	10-13	2.2-2.8	10-12
Receiver noise figure	F	dB	6	6	6	6	6	6	6
Equivalent noise bandwidth	B	MHz	6.66	6.66	6.66	1.54	6.66	1.54	6.66
Receiver noise input power	P_n	dBW	-129.7	-129.7	-129.7	-136.1	-129.7	-136.1	-129.7
Min. receiver signal input power	$P_{s\ min}$	dBW	-110.0	-111.9	-111.5	-126.1	-120.1	-126.1	-119.7
Min. equivalent receiver input voltage, 75 Ω	U_{min}	dB μ V	28.7	26.8	27.2	12.6	18.6	12.6	19.0
Feeder loss	L_f	dB	2	0	0	0	0	0	0
Antenna gain relative to half dipole	G_d	dB	7	-2.2	-2.2	-2.2	-17	-17	-17
Effective antenna aperture	A_a	dBm ²	1.7	-7.5	-7.5	-7.5	-22.3	-22.3	-22.3
Min power flux-density at receiving location	θ_{min}	dB(W)/m ²	-109.7	-104.4	-104.0	-118.6	-97.8	-103.8	-97.4

			Fixed	Portable outdoor/urban	Portable indoor/urban	Mobile/rural	Handheld portable outdoor	Handheld mobile Class H-D/integrated antenna	Handheld mobile Class H-D/integrated antenna
Min equivalent field strength at receiving location	E_{min}	$\text{dB}\mu\text{V/m}$	36.1	41.4	41.8	27.2	48.0	42.0	48.4
Allowance for man-made noise	P_{mmn}	dB	2	8	8	5	0	0	0
Penetration loss (building or vehicle)	L_b, L_v	dB	0	0	9	0	0	8	8
Standard deviation of the penetration loss		dB	0	0	3	0	0	2	2
Diversity gain	Div	dB	0	0	0	0	0	0	0
Location probability		%	70	70	70	90	70	90	90
Distribution factor			0.5244	0.5244	0.5244	1.28	0.5244	1.28	1.28
Standard deviation			5.5	5.5	6.3	5.5	5.5	5.9	5.9
Location correction factor	Cl	dB	2.8842	2.8842	3.30372	7.04	2.8842	7.552	7.552
Minimum median power flux-density at reception height ¹ ; 50% time and 50% locations	θ_{med}	dB(W)/m^2	-104.8	-93.5	-83.7	-106.5	-94.9	-88.2	-81.9
Minimum median equivalent field strength at reception height ¹ ; 50% time and 50% locations	E_{med}	$\text{dB}\mu\text{V/m}$	41.0	52.3	62.3	39.3	50.9	57.6	63.9
Location probability		%	95	95	95	99	95	99	99
Distribution factor			1.6449	1.6449	1.6449	2.3263	1.6449	2.3263	2.3263
Standard deviation			5.5	5.5	6.3	5.5	5.5	5.9	5.9

			Fixed	Portable outdoor/urban	Portable indoor/urban	Mobile/rural	Handheld portable outdoor	Handheld mobile Class H-D/ integrated antenna	Handheld mobile Class H-D/ integrated antenna
Location correction factor	CI	dB	9.04695	9.04695	10.36287	12.79465	9.04695	13.72517	13.72517
Minimum median power flux-density at reception height ¹ ; 50% time and 50% locations	θ_{med}	dB(W)/m ²	-98.7	-87.4	-77.7	-100.8	-88.8	-82.1	-75.7
Minimum median equivalent field strength at reception height ¹ ; 50% time and 50% locations	E_{med}	dB μ V/m	47.1	58.4	69.1	45.0	57.0	64.7	70.1

¹ 10 m for fixed reception and 1.5 m for the other reception modes.

3.3.2 DVB-T2 in Band IV/V

			Fixed	Portable outdoor/urban	Portable indoor/urban	Mobile/rural	Handheld portable outdoor	Handheld mobile Class H-D/ integrated antenna
Frequency	Freq	MHz	650	650	650	650	650	650
Minimum C/N required by system	C/N	dB	19.7	17.8	18.2	10.0	9.6	10.0
System variant (example)			256-QAM FEC 2/3, 32k, PP7 Extended	64-QAM FEC 2/3, 32k, PP4 Extended	64-QAM FEC 2/3, 16k, PP1 Extended	16-QAM FEC 1/2, 8k, PP1 Extended	16-QAM FEC 1/2, 16k, PP3 Extended	16-QAM FEC 1/2, 8k, PP2 Extended
Bit rate (indicative values)		Mbit/s	35-40	26-29	23-28	11-14	12-15	11-14
Receiver noise figure	F	dB	6	6	6	6	6	6
Equivalent noise bandwidth	B	MHz	7.77	7.77	7.77	7.71	7.77	7.71
Receiver noise input power	P_n	dBW	-129.1	-129.1	-129.1	-129.1	-129.1	-129.1
Min. receiver signal input power	$P_{s\ min}$	dBW	-109.4	-111.3	-110.9	-119.1	-119.5	-119.1
Min. equivalent receiver input voltage, 75 Ω	U_{min}	dB μ V	29.4	27.5	27.9	19.6	19.3	19.6
Feeder loss	L_f	dB	4	0	0	0	0	0
Antenna gain relative to half dipole	G_d	dB	11	0	0	0	-9.5	-9.5
Effective antenna aperture	A_a	dBm ²	-4.6	-15.6	-15.6	-15.6	-25.1	-25.1
Min power flux- density at receiving location	θ_{min}	dB(W)/m ²	-100.8	-95.7	-94.3	-103.5	-94.4	-94.0

			Fixed	Portable outdoor/urban	Portable indoor/urban	Mobile/rural	Handheld portable outdoor	Handheld mobile Class H-D/ integrated antenna
Min equivalent field strength at receiving location	E_{min}	dB μ V/m	45.0	50.1	50.5	42.3	51.4	51.8
Allowance for man-made noise	P_{mmn}	dB	0	1	1	0	0	0
Penetration loss (building or vehicle)	L_b, L_v	dB	0	0	11	0	0	8
Standard deviation of the penetration loss		dB	0	0	6	0	0	2
Diversity gain	Div	dB	0	0	0	0	0	0
Location probability		%	70	70	70	90	70	90
Distribution factor			0.5244	0.5244	0.5244	1.28	0.5244	1.28
Standard deviation			5.5	5.5	8.1	5.5	5.5	5.9
Location correction factor	C_l	dB	2.8842	2.8842	4.24764	7.04	2.8842	7.552
Minimum median power flux-density at reception height ¹ ; 50% time and 50% locations	θ_{med}	dB(W)/m ²	-97.9	-91.8	-79.1	-96.5	-91.5	-78.5
Minimum median equivalent field strength at reception height ¹ ; 50% time and 50% locations	E_{med}	dB μ V/m	47.9	54.0	66.7	49.3	54.0	67.3
Location probability		%	95	95	95	99	95	99
Distribution factor			1.6449	1.6449	1.6449	2.3263	1.6449	2.3263
Standard deviation			5.5	5.5	8.1	5.5	5.5	5.9
Location correction factor	C_l	dB	9.04695	9.04695	13.32369	12.79465	9.04695	13.72517

			Fixed	Portable outdoor/urban	Portable indoor/urban	Mobile/rural	Handheld portable outdoor	Handheld mobile Class H-D/ integrated antenna
Minimum median power flux-density at reception height ¹ ; 50% time and 50% locations	θ_{med}	dB(W)/m ²	-91.8	-85.7	-72.4	-90.8	-85.4	-72.3
Minimum median equivalent field strength reception height ¹ ; 50% time and 50% locations	E_{med}	dB μ V/m	54.0	60.1	75.8	55.0	60.4	73.5

¹ 10 m for fixed reception and 1.5 m for the other reception modes.

3.4 Protection ratios

3.4.1 Introduction

Protection ratios are required for compatibility considerations with regard to other radio systems. These cover intra-protection ratios (DVB-T2 vs. DVB-T2) and inter-protection ratios (DVB-T2 vs. other non-T2 radio systems, broadcasting as well as non-broadcasting), co-channel as well as adjacent channel protection ratios. In addition, overload thresholds are relevant criteria for the assessment of compatibility.

The information so far available is mainly collected from manufacturers' inputs to ITU-R Study Group 6, see Recommendation ITU-R BT.2033.

Measurement results are obtained for a particular reference mode of DVB-T2 which is described in § 3.4.2.2. A proposal how to translate these results for other DVB-T2 modes is described in § 3.4.6.

The protection ratios given in the subsequent sections are valid for 8 MHz bandwidth. It is assumed that these hold for 1.7, 5, 6 and 7 MHz bandwidth, too. Overload thresholds would have to be adapted to the bandwidth by taking 1.7/8, 5/8, 6/8 and 7/8 of the overload power, respectively.

3.4.2 DVB-T2 vs. DVB-T2/DVB-T

3.4.2.1 Co-channel

As usual for OFDM systems, it is expected that DVB-T2 intra-protection ratios (DVB-T2 vs. DVB-T2) for co-channel interference are identical to the respective C/N values. The same holds for the protection ratios DVB-T vs. DVB-T2.

It is therefore assumed that for planning purposes the co-channel protection ratios can be derived according to the methodology for C/N described in § 2.5.

Also for the protection ratios the receiving environment has taken account of, i.e. for a Rice or a Rayleigh channel environment the corresponding C/N should be used for the protection ratio.

3.4.2.2 Adjacent channel

In this section, results of measurements of adjacent channel protection ratios as reported in Recommendation ITU-R BT.2033 are collected. The reference DVB-T2 mode for the measurements is described in Table 3.3. In addition, overload thresholds are also collected from Recommendation ITU-R BT.2033. Moreover, in Table 3.4 the receiver statistics of the measurements are reflected by indication of the 50% and 90% percentiles for the protection ratio values and of 10% and 50% percentiles for the overload threshold values. In order to cover the majority of receivers, usually the 90% percentile for the protection ratio value and the 10% percentile for the overload threshold value are chosen.

In Annex A of ECC Report 148 [ECC148] a description can be found how protection ratios and overload thresholds are determined.

TABLE 3.3

**Reference DVB-T2 mode for measurements on protection ratios
(extract from Table 1 of Recommendation ITU-R BT.2033)**

Overall	Parameter value
FFT Size	32k
Bandwidth	8 MHz
Extended bandwidth mode	Yes
Pilot pattern	PP7
Modulation	256-QAM
Rate	2/3
FEC type	64800
Rotated QAM	Yes
<i>C/N</i> (AWGN Channel) (dB)	19.7
Data rate (Mbit/s)	40.2

It may be noted that the *C/N* given in Table 3.3 for this mode is for a Gaussian channel. It therefore differs slightly by 0.3 dB from the one given in § 5.2 which relates to a Ricean channel.

TABLE 3.4

**Protection ratios (dB) and overload threshold (dBm) for a DVB-T2 signal
interfered (defined in Table 3.3) with by a DVB-T2 signal (defined in Table 3.3) in adjacent
channels for silicon tuners (from Recommendation ITU-R BT.2033)**

Channel offset <i>N</i> (8 MHz channels)	Centre frequency offset (MHz)	Number of receivers tested	PR (dB)		<i>O</i> _{th} (dBm)	
			Percentile		Percentile	
			50 th	90 th	10 th	50 th
–9	72	11	–54	–50	–14	0
–4	–32	11	–50	–44	–14	–2
–3	–24	11	–48	–44	–14	–2
–2	–16	11	–47	–43	–15	–6
–1	–8	11	–35	–33	–15	–6
Co-channel	0	11	19.0	19.0	–	–
1	8	11	–32	–30	–15	–6
2	16	11	–46	–43	–15	–5
3	24	11	–47	–43	–14	–2
4	32	11	–50	–44	–13	1
9	72	11	–54	–49	–13	1

3.4.2.3 Extended DVB-T2 mode

A particular aspect, specific to DVB-T2, is the question whether the extended bandwidth mode of DVB-T2 imposes a higher interference to other DVB-T or DVB-T2 implementations than the normal

mode. First available results [IRT2011] indicate that an increase of only 0.2 to 0.3 dB is to be expected which would – in first approximation – be a negligible difference.

3.4.3 DVB-T2 vs. T-DAB

No information is available yet on protection ratios for DVB-T2 interfered with by T-DAB.

For the protection ratios of T-DAB interfered with by DVB-T2 it is assumed that the same values hold as they are reported for the interference by DVB-T. These can be found, e.g. in [RRC06].

3.4.4 DVB-T2 vs. Analogue TV

No information is available yet on protection ratios for DVB-T2 interfered with by Analogue TV.

For the protection ratios of Analogue TV interfered with by DVB-T2 it is assumed that the same values hold as they are reported for the interference by DVB-T. These can be found, e.g. in [RRC06].

3.4.5 DVB-T2 vs. LTE

From the large class of cases of interference of DVB-T2 with other (non-broadcasting) services the case of LTE is the most relevant one since close adjacent channel appearance in the UHF band is possible and even co-channel relationship may be relevant.

3.4.5.1 Co-channel

No information is available yet.

3.4.5.2 Adjacent channel

The case of adjacent channel interference of DVB-T2 by LTE was studied in the context of the discussion of the digital dividend¹ in Europe [ECC148]. The following tables show protection ratios and overload thresholds for three different traffic loadings on the LTE base station. The measurements were performed in 11 silicon tuner receivers.

Due to the time variation in the LTE signal, low traffic loadings cause degradations in protection ratios and overload thresholds in some receiver designs.

Again, the information is taken from Recommendation ITU-R BT.2033 and the same reference mode of DVB-T2 is used as in § 3.4.2.2. The characteristics of the LTE signal used in the measurements are given in Report ITU-R BT.2215 – Measurement of protection ratios and overload threshold for broadcast TV receivers.

Table 3.5 gives the information for DVB-T2 interfered with by an LTE base station (BS).

¹ The term “digital dividend” is defined as “The improved efficiency in the use of the spectrum, consequential to the digital switchover.

NOTE – This term is merely and specifically relevant to broadcasting”.

TABLE 3.5

Measured protection ratios (dB) for a DVB-T2 signal interfered with by
an LTE BS signal in adjacent channels for silicon tuners
(from Recommendation ITU-R BT.2033)

Channel Offset <i>N</i> (8 MHz channels)	Centre frequency offset (MHz)	Number of receivers tested	0% BS traffic loading PR (dB)		50% BS traffic loading PR (dB)		100% BS traffic loading PR (dB)	
			Percentile		Percentile		Percentile	
			50 th	90 th	50 th	90 th	50 th	90 th
Co-channel AWGN	0	11	19	19	19	19	19	19
Co-channel LTE	0	11	10	11	18	18	19	19
1	10	11	-44	-24	-40	-38	-38	-36
2	18	11	-50	-32	-48	-44	-47	-43
3	26	11	-51	-35	-49	-45	-48	-44
4	34	11	-52	-39	-51	-46	-50	-45
5	42	11	-53	-41	-51	-47	-51	-46
6	50	11	-55	-46	-54	-48	-52	-47
7	58	11	-56	-46	-54	-49	-54	-48
8	66	11	-57	-45	-54	-50	-53	-49
9	74	11	-58	-45	-55	-50	-53	-49

Un-corrected protection ratio values for interference by an LTE terminal (User Equipment: UE) are given in Table 3.6 below.

TABLE 3.6

Un-corrected protection ratios (dB) for a DVB-T2 signal (defined in Table 3.3) interfered with by an LTE UE signal in adjacent channels for silicon tuners

Channel offset <i>N</i> 8 MHz channels/ (centre frequency offset)	No. of Rx. tested	1 Mbit/s UE traffic loading Signal generator ACLR = 100 dB all offsets		10 Mbit/s UE traffic loading Signal generator ACLR = 100 dB all offsets		20 Mbit/s UE traffic loading Signal generator ACLR = 67.8 dB (N+1) 80.4 dB (N+2) 100 dB (N+3 to N+9)	
		PR percentile (dB)		PR percentile (dB)		PR percentile (dB)	
		50 th	90 th	50 th	90 th	50 th	90 th
Co-channel AWGN (0)	11	19	19	19	19	19	19
Co-channel LTE (0)	11	10	11	18	18	19	19
1/(10)	11	-36	-19	-41	-39	-41	-39
2 (18)	11	-41	-24	-47	-45	-47	-43
3 (26)	11	-44	-26	-48	-45	-50	-44
4 (34)	11	-46	-36	-48	-45	-52	-45
5 (42)	11	-47	-37	-48	-44	-54	-46
6 (50)	11	-50	-38	-49	-43	-52	-45
7 (58)	11	-50	-41	-49	-44	-53	-44
8 (66)	11	-50	-41	-49	-42	-54	-45
9 (74)	11	-50	-43	-49	-43	-54	-47

The UE protection ratios need to be corrected for the estimated UE ACLR in 8 MHz adjacent and non-adjacent channels to take account of the degradation in protection ratio caused by UE out-of band noise. The ACLR estimates are based on the mask in Table 6.6.2.1.1 of 3GPP TS 36.101 v.11.1.0 and the draft ETSI 301-908-13 requirement for -65 dBm out-of-band noise in the band 470-790 MHz. These are shown in Table 3.7 and were used for the corrected UE PR values shown in Table 3.8.

TABLE 3.7

Assumed UE ACLRs for corrected UE PR values

Channel offset <i>N</i> (8 MHz channels)	Centre frequency offset (MHz)	ACLR (dB)
1	10	25.2
2	18	32.2
Other offsets (corresponding to -65 dBm/8 MHz)	26-74	88.0

The ACLR correction method is described in Recommendation ITU-R BT.2033. The co-channel PR_0 values used in the correction calculation were the AWGN figures in Table 3.8.

It should be noted that, for a frequency offset Δf , the adjacent channel selectivity (ACS) of the receiver should be calculated from the un-corrected protection ratio at the offset ($PR(\Delta f)$).

Different ACLRs values than those appearing in Table 3.7, will require a recalculation of the corrected UE PR values.

TABLE 3.8

Corrected protection ratios (dB) for a DVB-T2 signal (defined in Table 3.3) interfered with by an LTE UE signal in adjacent channels for silicon tuners (from Recommendation ITU-R BT.2033)

Channel offset N 8 MHz channels/ (centre frequency offset)	No. of Rx. tested	1 Mbit/s UE traffic loading		10 Mbit/s UE traffic loading		20 Mbit/s UE traffic loading	
		PR percentile (dB)		PR percentile (dB)		PR percentile (dB)	
		50 th	90 th	50 th	90 th	50 th	90 th
Co-channel AWGN (0)	11	19	19	19	19	19	19
Co-channel LTE (0)	11	10	11	18	18	19	19
1/(10)	11	-6	-6	-6	-6	-6	-6
2 (18)	11	-13	-13	-13	-13	-13	-13
3 (26)	11	-44	-26	-48	-45	-50	-44
4 (34)	11	-46	-36	-48	-45	-52	-45
5 (42)	11	-47	-37	-48	-44	-54	-46
6 (50)	11	-50	-38	-49	-43	-52	-45
7 (58)	11	-50	-41	-49	-44	-53	-44
8 (66)	11	-50	-41	-49	-42	-54	-45
9 (74)	11	-50	-43	-49	-43	-54	-47

3.4.5.3 Overload

Similar measurements as for the adjacent channel case were performed for the case of overload. Table 3.9 gives the values for the base station case and Table 3.10 for the case of terminal interference.

TABLE 3.9

Measured overload thresholds (dBm) for a DVB-T2 signal (defined in Table 3.3) interfered with by an LTE BS signal in adjacent channels for silicon tuners (from Recommendation ITU-R BT.2033)

Channel offset N 8 MHz channels	Centre frequency offset (MHz)	Number of receivers tested	0% BS traffic loading O_{th} (dBm)		50% BS traffic loading O_{th} (dBm)		100% BS traffic loading O_{th} (dBm)	
			Percentile		Percentile		Percentile	
			10 th	50 th	10 th	50 th	10 th	50 th
1	10	11	-18	-6	-15	-6	-13	-8
2	18	11	-14	1	-12	-2	-13	-3
3	26	11	-12	3	-13	0	-12	-1
4	34	11	-11	5	-12	2	-12	0
5	42	11	-10	6	-12	3	-12	2
6	50	11	-10	4	-12	2	-12	2
7	58	11	-10	4	-11	2	-12	1
8	66	11	-10	4	-12	2	-12	1
9	74	11	-10	5	-12	3	-12	1

TABLE 3.10

Measured overload thresholds (dBm) for a DVB-T2 signal (defined in Table 3.3) interfered with by an LTE UE signal in adjacent channels for silicon tuners (from Recommendation ITU-R BT.2033)

Channel offset N 8 MHz channels)	Centre frequency offset (MHz)	Number of receivers tested	1 Mbit/s UE traffic loading		10 Mbit/s UE traffic loading		20 Mbit/s UE traffic loading	
			O_{th} (dBm)		O_{th} (dBm)		O_{th} (dBm)	
			10 th	50 th	10 th	50 th	10 th	50 th
1	10	11	-37	-6	-15	-5	-12	-5
2	18	11	-12	5	-11	0	-11	0
3	26	11	-10	6	-11	2	-11	0
4	34	11	-24	5	-11	2	-11	1
5	42	11	-10	6	-11	2	-11	1
6	50	11	-10	6	-11	2	-11	2
7	58	11	-10	5	-11	2	-11	2
8	66	11	-10	5	-11	2	-11	2
9	74	11	-11	6	-11	2	-11	2

3.4.6 Protection ratios for DVB-T2 modes other than the reference mode

The following method is proposed to adapt the above given protection ratios to DVB-T2 modes other than the reference mode described in § 3.4.2.2. This approach is to be regarded as a rough approximation. Additional measurements for other DVB-T2 modes would be desirable.

The C/N for the reference mode amounts to 19.7 dB in a Gaussian channel. If a protection ratio for a DVB-T2 mode other than the reference mode is required, the C/N for this mode is to be determined according to the methodology of § 2.5 while taking into account the receiving environment. The difference of this C/N value to 19.7 dB is to be applied to the protection ratio given in Tables 3.4 to 3.8 thus resulting in the required protection ratio.

However, it should be kept in mind that the accuracy becomes an issue with increasing difference of the C/N for the required mode and the reference mode.

3.5 DVB T2 equalization interval (EI)

The handling of echoes outside the guard interval for DVB-T2 should in principle be determined in the same way as in the case of DVB-T. However, for DVB-T2 the length and position of EI, the interval during which signals can be correctly equalized, must first be calculated as it is pilot pattern dependent. In DVB-T the pilot pattern was fixed which, for a given FFT size, also fixes the length of the EI.

Neglecting other interference sources, the equivalent total available $C/(N+I)$ [dB] in a given location can be determined by the formula below. To aid understanding the formula is illustrated in Fig. 3.1.

$$w_i = \begin{cases} 0 & \text{if } t \notin EI \\ \left(\frac{T_u + t}{T_u}\right)^2 & \text{if } t \in EI \text{ \& } t < 0 \\ 1 & \text{if } t \in EI \text{ \& } 0 \leq t \leq T_g \\ \left(\frac{(T_u + T_g) - t}{T_u}\right)^2 & \text{if } t \in EI \text{ \& } t > T_g \end{cases}$$

$$C = \sum_i w_i C_i$$

$$I = \sum_i (1 - w_i) C_i$$

where:

- C_i : power contribution from the i^{th} signal at the receiver input
- C : total power of the effective useful signal
- I : total effective interfering power
- w_i : weighting coefficient for the i^{th} component
- T_u : useful symbol length
- T_g : guard interval length
- t : signal arrival time relative to the beginning of the FFT window

EI: equalisation interval during which signals can be correctly equalized and therefore usefully contribute

T_p : length of the equalization interval (EI).

It should be noted that EI is an interval and not a value and can be considered to be an “equalization window”. The length of EI (which is T_p) is dependent upon the pilot pattern, but the positioning of this interval/window is chosen by the receiver. As long as the time between the first and the last received paths is less than T_p correct equalization is in principle possible. When this condition is not fulfilled the interference effect is accounted for by the equations above (zero w_i term for certain paths).

For a given length of the EI the optimum positioning of the EI depends on the impulse response of the channel. The positioning of the FFT window ($t = 0$) and therefore the beginning of the EI interval will be determined by the synchronization strategy adopted in the receiver. Further information about the positioning of EI can be found in the DVB-T2 implementation guidelines and in [BH2003]. Annex 6 also provides additional background information about the sharp transition at the edge of EI.

The receiver can operate satisfactorily in a given location when the aggregate available $C/(N+I)$ is larger or equal to the required C/N .

FIGURE 3.1

Weighting function $w_i(t)$ (with an equalization interval EI starting at $t = -t_a$)

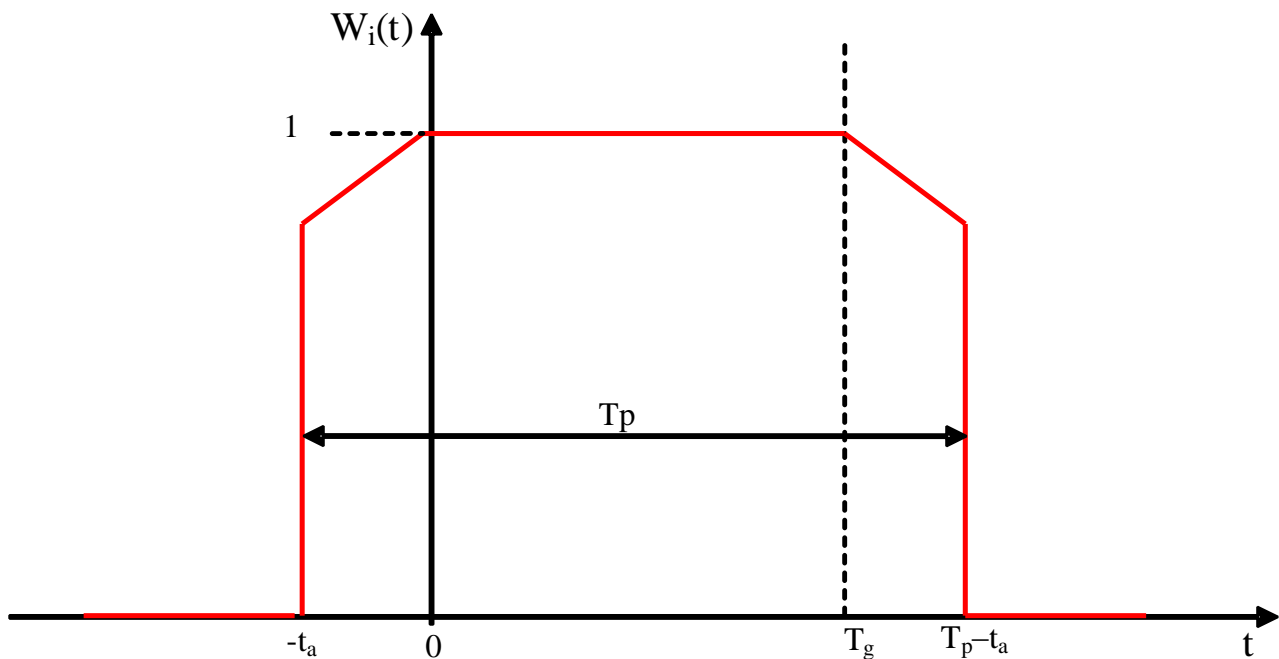

DVB-T2 receivers can equalize the channel by performing a 2-dimensional interpolation (time/frequency). This interpolation may either be fixed, independently of the particular channel or be adapted to the particular characteristics of the channel. In practice all receivers support combined time/frequency interpolation. Receivers with adaptive interpolation may use frequency-only interpolation in cases where there is a need for better Doppler performance and where the echoes are short enough in relation to the used FFT size and pilot pattern. For fixed reception, where Doppler performance is normally not a problem, combined time/frequency interpolation is normally used.

Combined time and frequency interpolation allows for the use of transmission modes with less dense pilot patterns, and therefore a greater payload.

TABLE 3.11

Nyquist limits for f-only and t-and-f-interpolation (from [TS 102 831])

Pilot Pattern	D_X (Separation of pilot-bearing carriers)	D_Y (No. of symbols forming one scattered pilot sequence)	Nyquist limit as fraction of T_U , for <i>f</i> -only interpolation	Nyquist limit as fraction of T_U , for <i>t</i> - and <i>f</i> -interpolation
PP1	3	4	1/12	1/3
PP2	6	2	1/12	1/6
PP3	6	4	1/24	1/6
PP4	12	2	1/24	1/12
PP5	12	4	1/48	1/12
PP6	24	2	1/48	1/24
PP7	24	4	1/96	1/24
PP8	6	16	1/96	1/6

In order to determine T_p the Nyquist limit must first be determined. Table 3.11 shows the Nyquist limit as a fraction of T_u , the useful symbol length, for the different DVB-T2 pilot patterns. T_u is provided for frequency only interpolation as well as combined time and frequency interpolation. More detailed information regarding the Nyquist limit for the available combinations of guard intervals and scattered pilot patterns is provided in Annex 3.

For network planning purposes it can be assumed that a DVB-T2 receiver is able to correctly equalize the signal for echoes up to $57/64$ (= 89.1%) of the Nyquist time for the scattered pilots (after time interpolation) for a particular FFT size, pilot pattern and RF bandwidth. Note that the factor of $57/64$ depends only upon the pilot pattern and not the guard interval.

T_p can then be calculated but the real positioning of this “equalization window” depends on the actual distribution of the received signals which arrive along different paths. Table 3.12 contains examples for some DVB-T2 modes based upon using both time and frequency interpolation.

NOTE – For ‘UHF 5’ (in Table 3.12 below) with the combination 32k FFT size, pilot pattern PP7 and 1/128 GI fraction, the receiver cannot be assumed to perform the combined time/frequency interpolation since it would require more memory in the receivers. Since the guard interval is very short for this mode, frequency-only interpolation will work well.

TABLE 3.12

Calculation of interval of correct equalization for some DVB-T2 modes

MODE	UHF 1 (Medium area SFN-Rooftop)	UHF 2 (Large area SFN-Rooftop)	UHF3 (Medium area SFN-Rooftop)	UHF 4 (Large area SFN-Portable)	UHF 5 (MFN rooftop, using SFN fill in)
Modulation	256-QAM	256-QAM	256-QAM	16-QAM	256-QAM
FFT size	32k	32k	32k	16k	32k
Code rate	2/3	3/4	3/5	1/2	3/5
Pilot pattern	PP4	PP2	PP4	PP3	PP7
Guard interval fraction	1/16	1/8	19/256	1/8	1/128
T_g (μs)	224	448	266	224	28
T_u (μs)	3584	3584	3584	1792	3584
Nyquist limit as fraction of T_u	1/12	1/6	1/12	1/6	1/96
Nyquist limit (μs)	299	597	299	299	37
Equalization factor	57/64	57/64	57/64	57/64	57/64
T_p time (μs)	266	532	266	266	33

It can be seen from the above that T_p is the same as, or slightly larger than the guard interval length T_g . This means that the degradation beyond the guard interval will be graceful from the end of the guard interval up to the end of the interval EI. This also applies for pre-echoes as long as the pre-echo lies within the interval EI.

For planning purposes, it is recommended to assume the use of combined time and frequency interpolation as this is the predominant mode of operation. If, however, the pilot pattern is matched to the echo lengths that are expected in the network, i.e. a high density pilot pattern used in a network primarily designed as an MFN or with only limited area SFNs, frequency-only interpolation could also be possible. Frequency-only interpolation could be of interest for portable and mobile reception where Doppler performance is more critical.

4 New planning features

4.1 SFN extension

4.1.1 Introduction

In this section, examples of network coverage simulations are presented to show the benefits that may be gained by upgrading the sample networks to DVB-T2 while otherwise leaving the physical network, transmitted powers and antenna patterns unchanged. Each example shows the clear benefit of DVB-T2 over DVB-T.

Since the simulations were performed by different sources, the particular C/N values that were used for the calculations are not necessarily the same nor do they necessarily coincide with the values proposed in § 2.5.

4.1.2 Example 1: Rooftop reception, SFN, large area, VHF

The first example describes a scenario for fixed rooftop reception in VHF band III, channel 6, in a large area SFN with three transmitters. The scenario is located in Finland and the simulation was performed by Progira.

FIGURE 4.1

Rooftop reception, SFN, large area, VHF, DVB-T in Finland

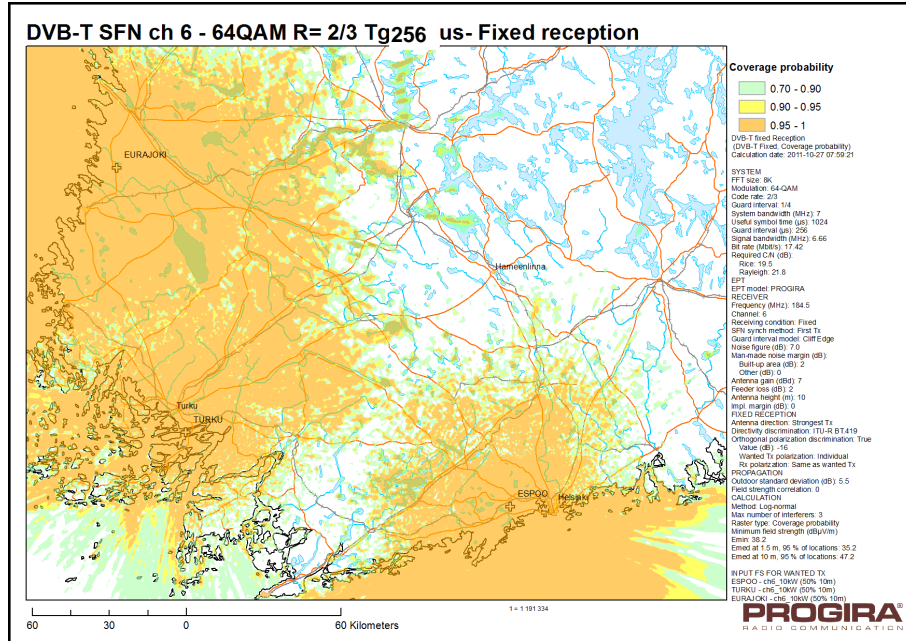

DVB-T
7 MHz, ch 6
8k, 64-QAM-2/3
GI 1/4 (256 μs)
C/N = 19.5 dB
17.4 Mbit/s

Figure 4.1 shows the coverage for a DVB-T implementation. A 64-QAM $CR = 2/3$ mode is chosen with the largest possible guard interval of 256 μs in order to minimize self-interference. However, self-interference degradation is not negligible in this network, as can be seen from the figure, as the 100+ km distance between the transmitters exceeds the guard interval. The C/N for this mode is 19.5 dB with a data rate of 17.4 Mbit/s.

Operating the network with a DVB T2 mode 256 QAM $CR = 2/3$, guard interval 512 μs, would improve the coverage remarkably, as can be seen from Fig. 4.2. Coverage holes induced by self-interference in the DVB T network could be avoided and, in addition, a much greater data rate of 31.4 Mbit/s would be available. At 20.2 dB the C/N is slightly higher for the DVB T2 mode than the corresponding DVB T mode.

FIGURE 4.2

Rooftop reception, SFN, large area, VHF, DVB-T2 in Finland

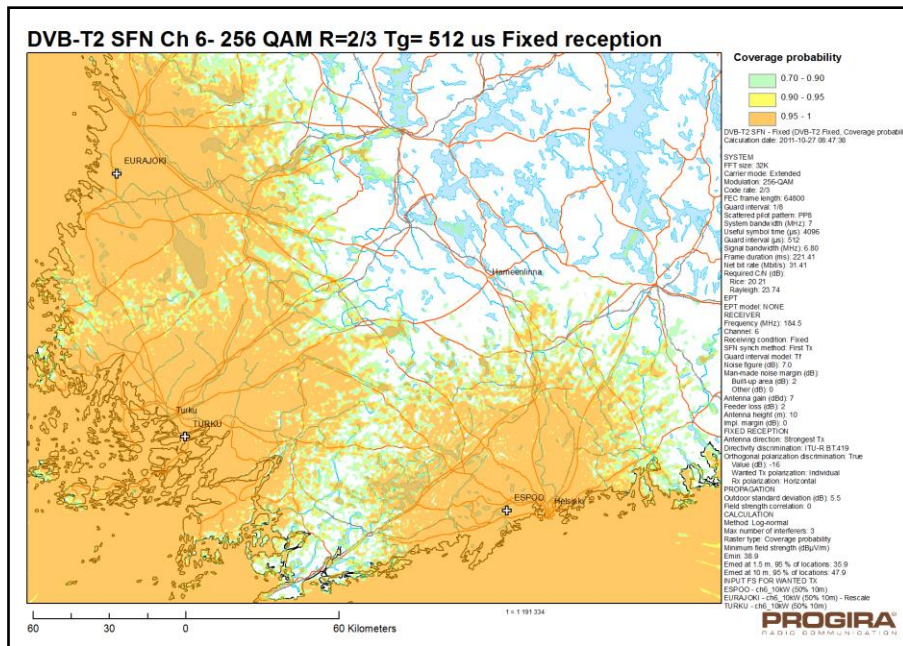

DVB-T2
7 MHz, ch 6
32k, 256-QAM-2/3
GI 1/8 (512 µs)
 $C/N = 20.2$ dB
31.4 Mbit/s

4.1.3 Example 2: Portable reception (with 64-QAM), SFN, large area, VHF

The second example considers the same network, again in channel 6 and with the same DVB-T mode, but now targeted to portable reception. Figure 4.3 shows the result of the simulation. Self-interference is now the dominant coverage limiting factor since portable reception does not incorporate the directivity of receiving rooftop antennas.

The coverage of this network, operating with DVB-T, would likely be considered inadequate for portable reception, and would not be practical. In practice a greater transmitter density or an MFN would be required to improve coverage to an acceptable level.

FIGURE 4.3

Portable reception, SFN, large area, VHF, DVB-T in Finland

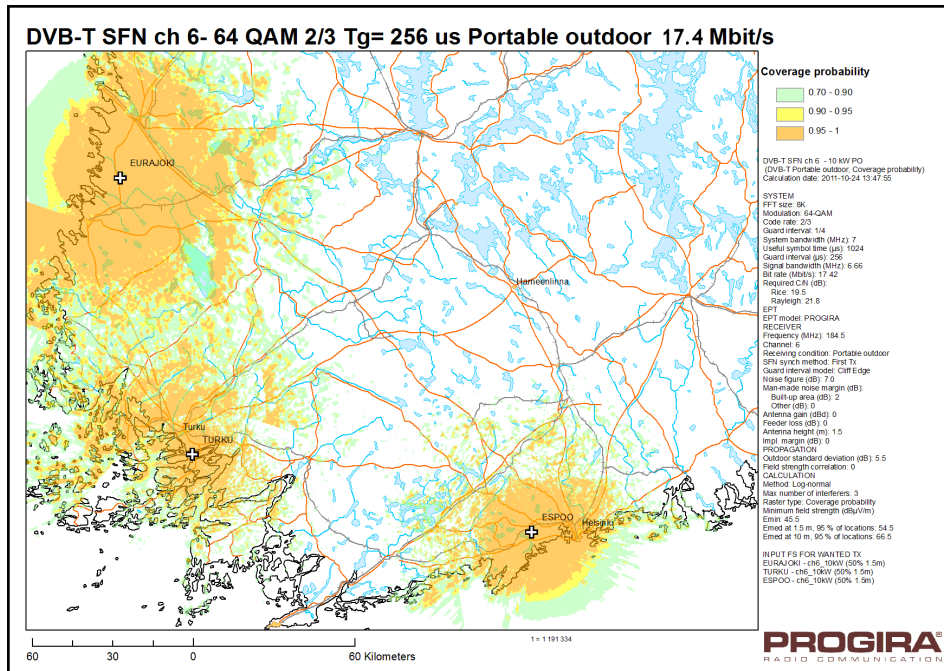

DVB-T
7 MHz, ch 6
8k, 64-QAM-2/3
GI 1/4 (256 µs)
C/N = 21.8 dB
17.4 Mbit/s

The situation would be markedly improved for a DVB-T2 implementation where a longer guard interval could avoid the deleterious self-interference effects. In Fig. 4.4 the DVB-T2 mode 64-QAM CR = 3/5 has been modelled, providing a similar data rate to the DVB-T mode above. Now large areas are covered and the sparse transmitter network may prove viable.

FIGURE 4.4

Portable reception, SFN, large area, VHF, DVB-T2 in Finland

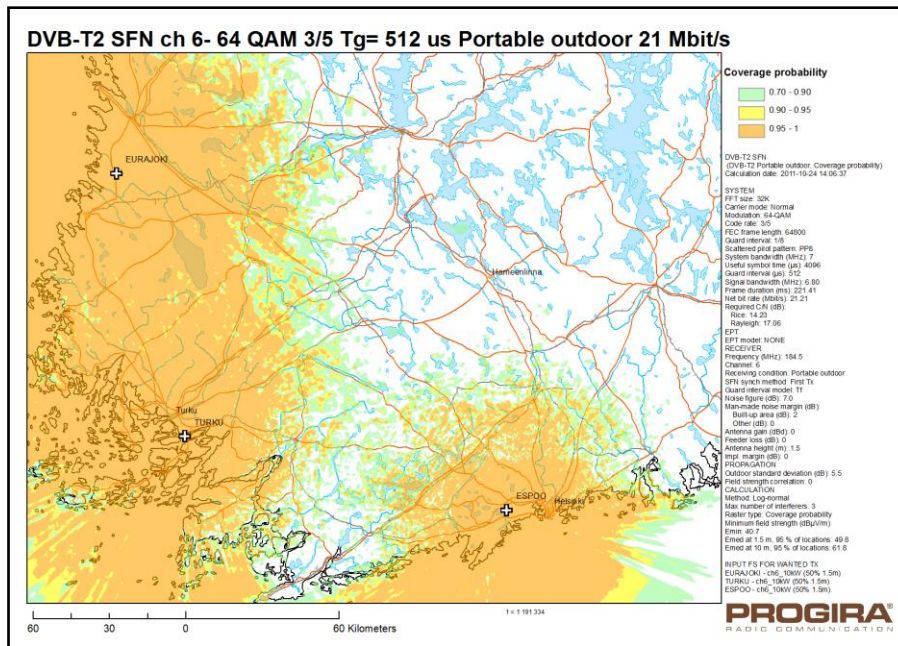

DVB-T2
 7 MHz, ch 6
 32k, 64-QAM-3/5
 GI 1/8 (512 μ s)
 $C/N = 17.1$ dB
 21.2 Mbit/s

4.1.4 Example 3: Portable reception, SFN, medium area, UHF

The third example describes a scenario for portable reception in the northern part of Germany, as calculated by NDR. The SFN consists of four transmitters and uses UHF channel 47. The coverage of the realistic DVB-T implementation is depicted in Fig. 4.5: Yellow indicates indoor reception, red outdoor reception and green rooftop reception. The DVB-T mode is 16-QAM CR = 2/3 with a guard interval of 224 μ s, providing a data rate of 13.3 Mbit/s.

FIGURE 4.5
 Portable reception, SFN, medium area, UHF, DVB-T
 in the northern part of Germany

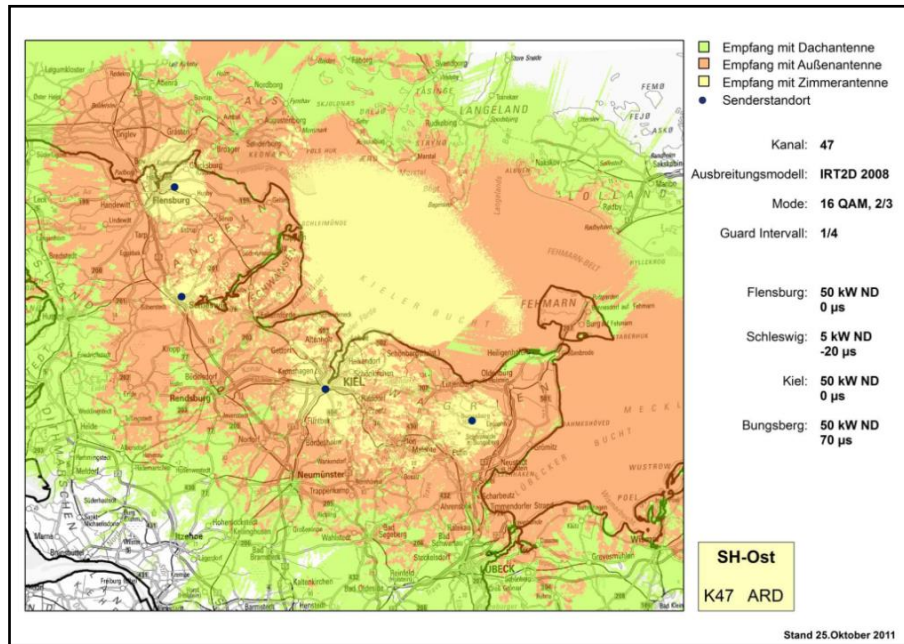

DVB-T
 8 MHz, ch 47
 8k, 16-QAM-2/3
 GI 1/4 (224 μ s)
 $C/N = 17.2$ dB
 13.3 Mbit/s

FIGURE 4.6

Portable reception, SFN, medium area, UHF, DVB-T2
in the northern part of Germany

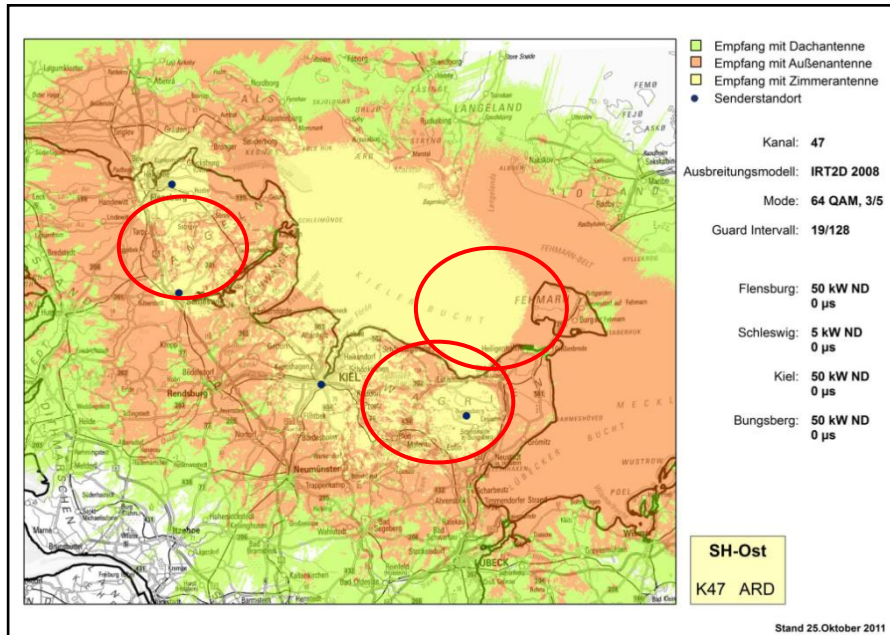

DVB-T2
 8 MHz, ch 47
 16k, 64-QAM-3/5
 GI 19/128 (266 μs)
 $C/N = 15.5$ dB
 23.0 Mbit/s

An improvement of the SFN performance is achieved by employing DVB-T2 mode 16k, 64-QAM CR = 3/5 with a guard interval of 266 μs. The data rate is remarkably increased to 23.0 Mbit/s and self-interference degradation is reduced, as is indicated in Fig. 4.6 by red circles.

4.1.5 Example 4: Portable reception, SFN, large area, UHF

The fourth example is a DVB-T2 planning exercise in Bavaria, calculated by IRT, in the UHF band. The network comprises 10 transmitters and is intended for portable outdoor reception. The DVB-T2 mode is 16k, 64-QAM CR = 2/3 with a large guard interval of 448 μs. The data rate is 22.6 Mbit/s and the coverage area extents to 150 km by 250 km. The good coverage that can be achieved with only minor self-interference degradation is shown in Fig. 4.7.

FIGURE 4.7

Portable reception, SFN, large area, UHF, DVB-T2 in Bavaria

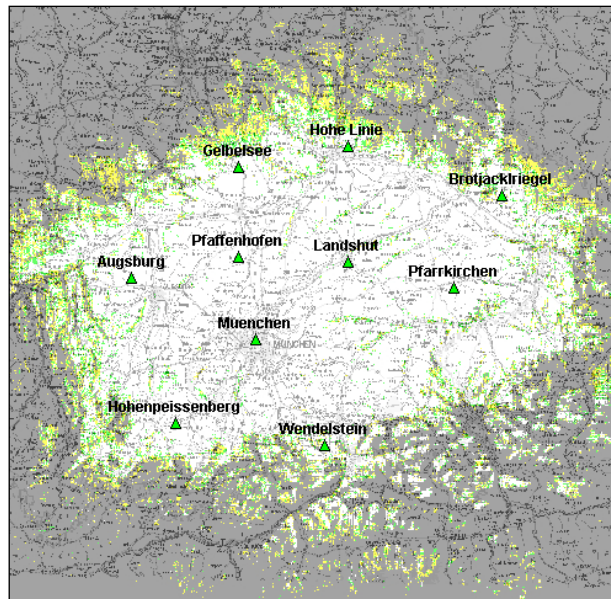

DVB-T2
8 MHz, ch 47
16k, 64-QAM-2/3
GI 1/4 (448 μ s)
C/N = 17.5 dB
22.6 Mbit/s

In Fig. 4.8 the coverage of the same hypothetical network is calculated with an appropriate DVB-T mode. The DVB-T mode with the largest guard interval and a comparable robustness has been modelled: 8k, 16-QAM CR = 2/3, guard interval 224 μ s. Even with these favourable parameters the coverage is severely limited by self-interference. For this reason such large DVB-T networks have never been realized – rather, a multi-frequency approach would be required in this case and two or three channels would be required to achieve the same coverage.

The example clearly shows the benefits that may be achieved with DVB-T2.

FIGURE 4.8

Portable reception, hypothetical SFN, large area, UHF, DVB-T in Bavaria

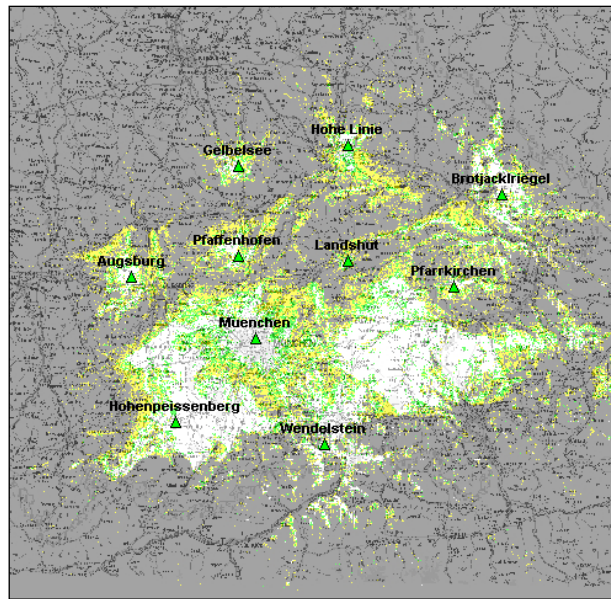

DVB-T 8 MHz, ch 47 8k, 16-QAM-2/3 GI 1/4 (224 μ s) C/N = 17.2 dB 13.3 Mbit/s

4.2 Degradation beyond guard interval

The length of the guard interval, as mentioned in § 4.1, is the most significant and obvious improvement when it comes to handling long delayed echoes in SFNs. However handling of signals arriving outside the guard also has a significant effect upon the SFN performance.

The performance of DVB-T2 system outside the guard interval is mainly determined by two factors which are essentially the same as in the case of DVB-T. They are:

- The symbol time: longer symbol time, when using higher (e.g. 16k or 32k) FFT, will improve performance outside the guard interval since guard interval fraction becomes smaller when using the same length of the guard interval.
- Interval of correct equalization.

Whereas the second factor is dealt with in § 3.5, the use of longer symbol times is discussed in the following section.

4.2.1 Use of higher FFT modes

The choice of a higher FFT mode with an accordingly larger symbol length includes an additional SFN coverage improvement which results from the fact that SFN self-interference, resulting from time delays beyond the guard interval, scales with the symbol length. Whereas the effect of a larger guard interval is discussed in § 4.1 the effect of a larger symbol length is discussed in this section. However, it is to be noted that the latter effect is secondary, less important than the former one. The effect is described in more detail in [EDP089].

Signals with time delays beyond the guard interval contribute destructively, with increasing weight for increasing time delays. This deleterious effect scales with the symbol length. As an example, a

hexagon network with the corresponding coverage area for an 8k and a 32k FFT was investigated. The network parameters are given in Table 4.1. Figure 4.9 compares the coverage areas of the two scenarios and Fig. 4.10 shows the difference in coverage.

TABLE 4.1

Network parameters

Transmitters	7, hexagon
T_x distance	50 km
Antenna height	150 m, nd
T_x power	100 kW
DVB-T2 variant	16-QAM 5/6
8k FFT GI	1/4 (224 μ s)
32k FFT GI	1/16 (224 μ s)
C/N	\sim 16.4 dB
Reception mode	Portable outdoor

FIGURE 4.9

Comparison of the coverage areas for the 8k and the 32k FFT mode

FIGURE 4.10
Difference in coverage



It can be seen that the difference is effective at the fringe of the coverage area and the increase of the symbol length may help to fill some coverage deficiencies caused by self-interference. However, the effect is not suited to heal larger coverage gaps due to self-interference. Moreover, in order to benefit from the effect it is to be ensured that receivers behave approximately in the theoretical manner. It is well known that in the past many receivers had abrupt cliff-edge behaviour at or very close to the edge of the guard interval.

4.3 MISO (multiple input single output)

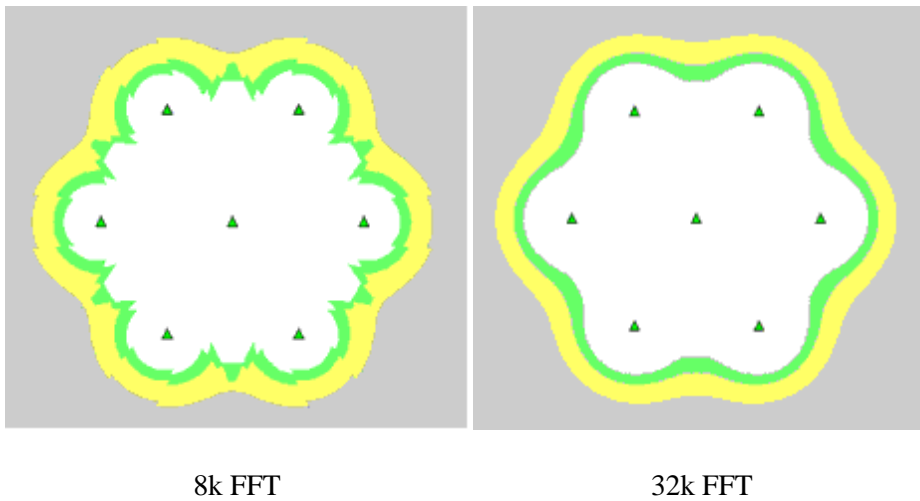
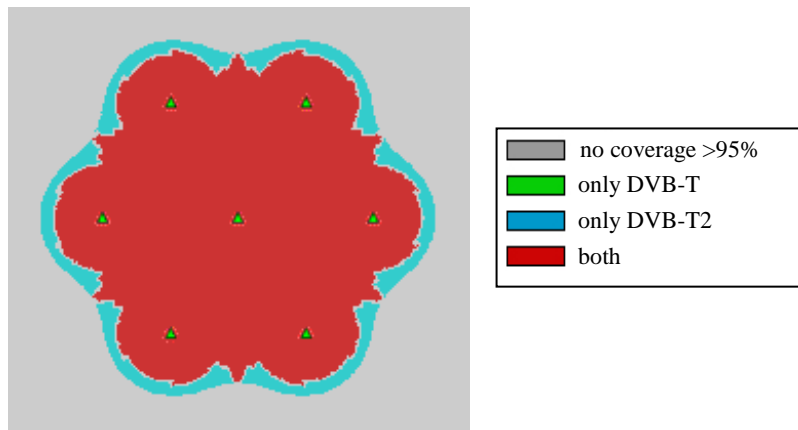
4.3.1 General considerations

The DVB-T2 standard introduces the ability to implement MISO, or MISO networks, a network configuration not available in DVB-T. A general MISO network configuration is shown in Fig. 4.11. Referring to the diagram it can be seen that one of the main points of difference between a MISO and a standard broadcasting network is that the MISO network transmits two slightly different versions of the wanted signal from a number of different transmitters at the same time. Usually, though not necessarily, the transmitters are geographically separated from each other as this is generally the most beneficial configuration. By transmitting multiple wanted signals, the network is able to incorporate the advantages of transmit diversity in order to improve the system's SNR and subsequently the network's coverage or data rate.

FIGURE 4.11
A general DVB-T2 MISO network

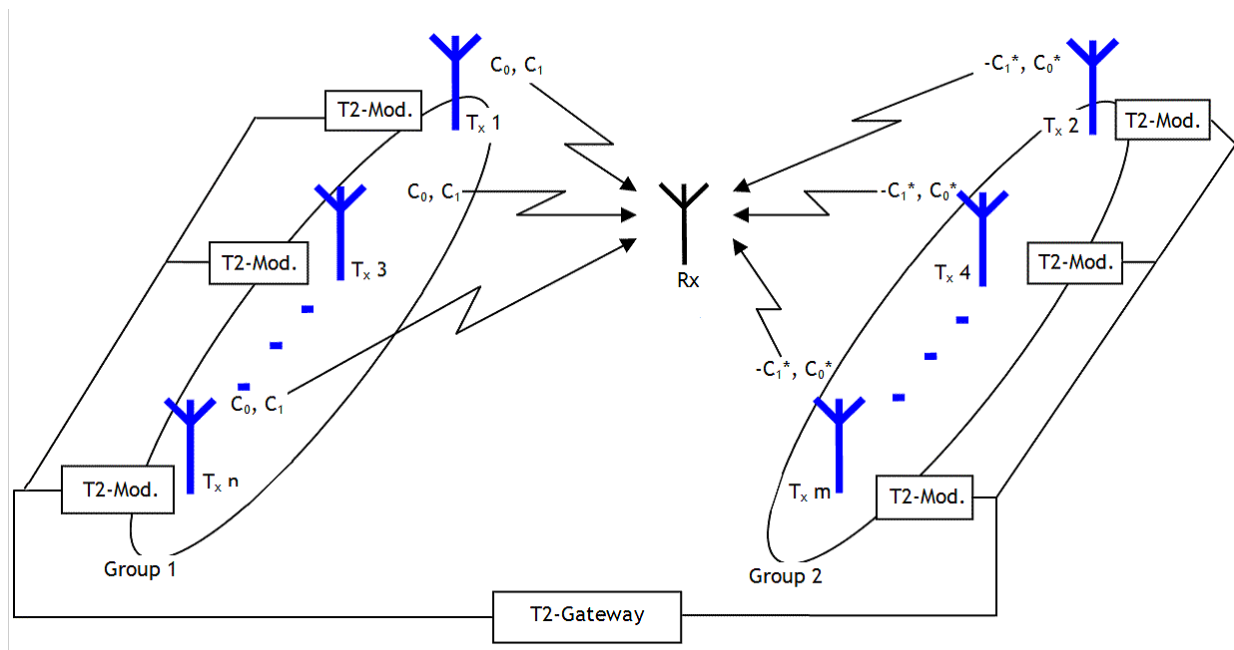

A DVB-T2 MISO network should be viewed as a particular form of an SFN, as the multiple transmissions require synchronization and timing in much the same way as a ‘standard’ SFN.

The DVB-T2 standard is based on a modified form of Alamouti’s scheme, one of a number of different possibilities. One of the main benefits of this particular scheme is that it can be implemented in a relatively straightforward manner that requires little additional complexity at both the transmit and receive sides of the network. Using only a *single* receive antenna the Alamouti scheme allows improvements in the received SNR equivalent to that obtained from a receive diversity system incorporating *two* receive antennas and a maximal ratio combining scheme. It also ensures that the ripples and notches that can form in a standard, two stations, SFN channel, which subsequently degrade the system’s SNR, do not occur in a MISO network as the two transmitted signals are no longer identical so destructive signal combination is essentially avoided. In a Gaussian channel, a 3 dB improvement in SNR could be achieved compared with the same network utilizing a ‘standard’ SFN. Slightly greater gains are possible in locations of similar receive levels. Although it is not without its trade-offs, Alamouti coding can improve coverage, allow a greater data rate or more efficient spectrum usage, or a combination of these outcomes.

The basic operation of the Alamouti based MISO network can be understood by referring to Fig. 4.11. Each of the network’s multiple transmitters is assigned to one of two Groups where each transmitter can be thought to transmit payload cells in pairs. Transmitters in Group 1 transmit an unmodified version of every constellation, just as they would in a ‘standard’ SFN – neither buffering nor negation or complex conjugation is applied. The first pair of cells is shown as C_0 and C_1 in the diagram. Transmitters in Group 2 however, transmit a slightly modified version of each constellation pair, and in reverse frequency order². Group 2 transmits $-C_1^*$ and C_0^* where $*$ denotes the complex conjugation operation.

The receiver then recovers the components from the combined signals in a relatively straightforward manner that requires little additional complexity compared with a standard, non-MISO receiver.

² For example, if C_0 is transmitted on carrier n for transmitters in Group 1, then C_1 would be transmitted on carrier $n + 1$. Simultaneously, the transmitters in Group 2 would transmit $-C_1^*$ on carrier n and C_0^* on carrier $n + 1$. The Alamouti coding is carried out in the frequency direction rather than the time direction.

The diagram also shows two pieces of equipment that are required in order for the network to operate correctly: the T2-Gateway and the DVB-T2 modulator. The T2-Gateway produces a T2-MI (T2-Modulator Interface) stream that contains all the information required to describe both the content and emission timing of T2-frames. The T2-MI stream is fed to the T2 modulators which apply the desired delays and the Alamouti coding.

As the diagram shows, all transmitters in the MISO network are locked to the same clock reference so the signals can be appropriately synchronized and delayed in a manner similar to a ‘standard’ SFN. Usually a GPS is used for this purpose.

It is also worth noting that the diagram shows an unlimited number of transmitters per Group. Although that is possible, it is not likely to occur in practice where two or three transmitters per Group would be more common.

4.3.2 Transmission parameter considerations

It should be noted that the DVB-T2 specification limits the maximum guard interval fraction (GIF) to 1/8. Subsequently, geographical SFN sizes could be limited. Furthermore, the scattered-pilot pattern chosen for a given FFT size and guard interval generally needs to be twice as dense because only half of the pilots are used for each of the sum and difference channel estimates – a factor that reduces capacity.

Both of the above factors should be considered when determining the suitability of a MISO network to a particular application.

4.3.3 Planning applications and considerations

In general, MISO should be considered for networks designed with a GIF up to 1/8 where capacity is not the limiting factor. In situations such as these where a ‘standard’ SFN might have been previously utilized, a MISO network may be more beneficial.

Moreover, the Alamouti coding is most beneficial when signals of equal magnitude from the two different transmitter groups are combined. Consideration should therefore be given to maximizing signal overlaps between the two groups as that would yield the largest gains. Conversely the scheme would be of limited benefit in networks with little overlap, particularly given the increased overhead.

Portable and mobile networks would typically be most likely to benefit from the scheme as they generally contain more omnidirectional reception antennas, which would increase the likelihood of similar strength signals overlapping. Furthermore, for these types of network and for mobile networks in particular, their transmitter network tend to be denser and the transmitters often have lower powers, which would likely increase overlaps further.

Perhaps the situation that a MISO network would most suit is one in which an area such as a large town is broadly served by two main transmitters which have overlapping signals. In this case one transmitter could be assigned to each transmitter group. The maximum potential of MISO might then be realized.

Fixed reception networks with relatively highly directional antennas may not be well suited to a MISO network unless the transmit antennas were located relatively close together so they fell roughly within the beam-width of a majority of the receive antennas. On the other hand, it may be possible to provide improvement to localised areas in such networks, particularly if the transmitters fell within the beam-width of the receive antennas.

Since there are only two possible “variants” of the transmitted signal when MISO is applied, it may in practice be difficult to arrange the transmitter in two groups in order to maximize the MISO gain in large area SFNs. However for example in a network with one central main transmitter surrounded by several small SFN-fill-in transmitters, it may be possible to take advantage of the MISO gain more

efficiently. The overlap between the fill-in sites would then be small and coverage overlap would exist between the main transmitter and the fill-in sites. The main transmitter would then be assigned to one transmitter group and the fill-in sites to the other transmitter group.

Moreover, there is a restriction with regard to the choice of the guard interval. Table 4.2 shows the possible combinations of guard interval and scattered pilot pattern in MISO mode.

TABLE 4.2
Scattered pilot pattern to be used for each allowed combination of FFT size and guard interval in MISO mode (from [EN 302 755])

FFT size	Guard interval						
	1/128	1/32	1/16	19/256	1/8	19/128	1/4
32k	PP8 PP4 PP6	PP8 PP4	PP2 PP8	PP2 PP8	<i>n/a</i>	<i>n/a</i>	<i>n/a</i>
16k	PP8 PP4 PP5	PP8 PP4 PP5	PP3 PP8	PP3 PP8	PP1 PP8	PP1 PP8	<i>n/a</i>
8k	PP8 PP4 PP5	PP8 PP4 PP5	PP3 PP8	PP3 PP8	PP1 PP8	PP1 PP8	<i>n/a</i>
4k, 2k	<i>n/a</i>	PP4 PP5	PP3	<i>n/a</i>	PP1	<i>n/a</i>	<i>n/a</i>
1k	<i>n/a</i>	<i>n/a</i>	PP3	<i>n/a</i>	PP1	<i>n/a</i>	<i>n/a</i>

In MISO mode, guard interval 1/4 is not possible. Therefore, in large SFNs, MISO seems to be feasible only if FFT modes higher than 8k are applied.

4.3.4 Qualitative description of the MISO gain

As shown in the section above the MISO gain depends on the level difference. Figure 4.12 shows the qualitative effect of the level difference.

FIGURE 4.12
MISO gain as a function of level difference (MISO gain = difference of min. required levels)

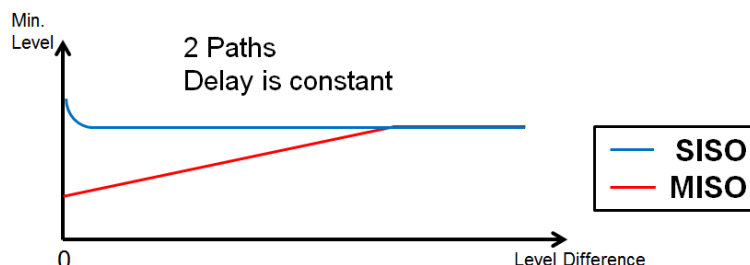

Furthermore, the performance of MISO is also a function of the delay time. The channel estimation and/or correction is performed on pairs of cells, basically two adjacent sub-carriers. This means that MISO will work best if these adjacent sub-carriers are faded very similarly. This is the case for short delays. Long delays fade adjacent sub-carriers differently. Therefore an error is introduced that decreases the MISO effect. It might even occur at very large echoes that the MISO effect becomes a

negative gain. The exact function needs to be verified by measurements. Figure 4.13 illustrates the qualitative effect of increasing delay.

FIGURE 4.13
MISO gain as a function of relative delay (MISO gain = difference of min. required levels)

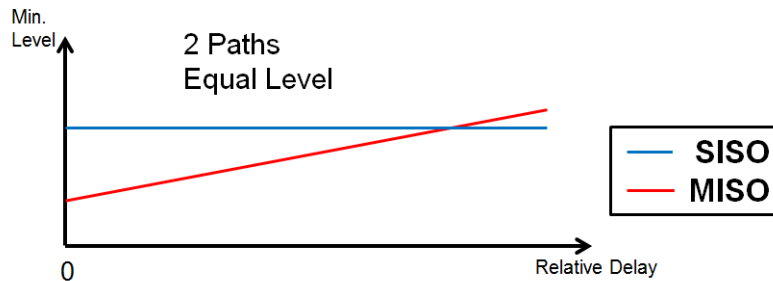

The implementation guideline [TS 102 831] does not give results of MISO simulations; but results of at least two field trials are available.

4.3.5 Results of MISO field trials

A field trial in the northern part of Germany [Nord2012] investigated the MISO performance for portable reception in a 2-transmitter SFN. 16-QAM and 64-QAM modulations were tested for several code rates with 16k and 32k FFT. MISO gain was found only in the region inbetween the two transmitters where their coverage overlaps. This is what would be expected, but the gain was only between 0.5 dB and 1.5 dB, whereas theoretically it should be 2 to 3 dB. In some other locations the signal was found to be degraded by 1 to 2 dB. The conclusion of this field trial was that relative to an equivalent SFN, no significant gain with MISO can be achieved.

Another field trial in the southern part of Germany [Mo2013] came to a similar conclusion. The 64-QAM mode with several code rates and 32k FFT was investigated for fixed reception in a 3-transmitter SFN using a consumer receiver as well as a software-defined (SDR) DVB-T2 receiver. MISO gains of 2 to 3 dB were recorded for locations inbetween the transmitters where the power imbalance of the signals received from the two MISO groups was less than 2 to 3 dB. At some other locations MISO losses of up to 1 dB were found. Higher code rates were found to benefit more from MISO than lower code rates.

A typical measurement result is shown in Fig. 4.14, where the required C/N is plotted against the power imbalance at the receiving location of the two MISO groups and compared with the SISO mode. The MISO mode only performs better than the MISO mode where the power imbalance is less than 2 dB.

FIGURE 4.14

Required C/N as a function of the power imbalance of the two MISO groups and the same network configuration when operated in SISO mode for the SDR receiver and DVB-T2 mode 64-QAM 3/4 (from [Mo2013])

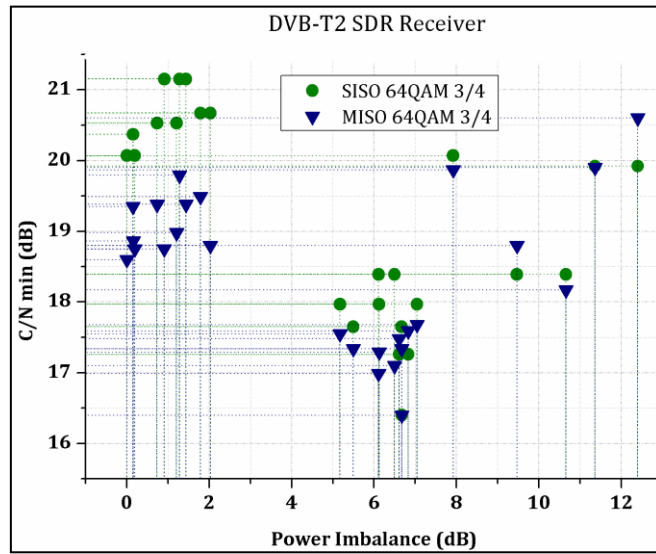

Table 4.3 collects the results of the measurement campaign. Mean values and standard deviations of the measured MISO gains are provided. Results are provided for three channel profiles: SFN, Rice and Rayleigh. In this context the SFN profile is characterized by a multipath environment where the received signals have a power imbalance of less than 3 dB. Other channel profiles with larger imbalance values which are also common in single frequency networks are categorized according to the standard Rice and Rayleigh characteristics. Only the SFN profile shows MISO gain in the order of 1 dB to 2.5 dB, whereas all other cases show no gain or even losses.

TABLE 4.3

Measured MISO gains from the Munich field trial (from [Mo2013])

MEASURED EMPIRICAL MISO GAIN				
<i>64QAM 2/3</i> LDPC 64800, 32k FFT, GI 1/16, PP2				
CHANNEL PROFILE	<i>Munich MISO Gain (dB)</i>			
	<i>STB A</i>		<i>SDR Rx</i>	
	<i>Mean</i>	σ	<i>Mean</i>	σ
<i>SFN</i>	1.84	0.28	1.13	0.16
<i>Ricean</i>	0.32	0.1	-0.13	0.26
<i>Rayleigh</i>	-0.76	0.48	-0.32	0.37

MEASURED EMPIRICAL MISO GAIN				
<i>64QAM 3/4</i> LDPC 64800, 32k FFT, GI 1/16, PP2				
CHANNEL PROFILE	<i>Munich MISO Gain (dB)</i>			
	<i>STB A</i>		<i>SDR Rx</i>	
	<i>Mean</i>	σ	<i>Mean</i>	σ
<i>SFN</i>	2.45	0.23	1.58	0.21
<i>Ricean</i>	0.17	0.26	0.25	0.18
<i>Rayleigh</i>	-0.85	0.03	-0.13	0.15

In addition, in [Mo2013] the performance of MISO with regard to the signal delay in an SFN was investigated. System level simulations were taken in the laboratory with the SDR receiver in an emulated SFN with two delayed transmitter paths for a distributed Ricean channel. As an example, Fig. 4.15 shows the required C/N as a function of the power imbalance and delay time between the two signals for both MISO and SISO. The DVB-T2 mode is 32k FFT 64QAM 2/3, guard interval 1/32. This guard interval corresponds to 112 μ s.

Again, the MISO gain for small power imbalance values can be observed. The performance degrades smoothly with increasing delay until nearly the guard interval limit. There a significant difference between MISO and SISO mode appears. Whereas MISO degrades rapidly, SISO still shows acceptable performance even beyond the guard interval.

FIGURE 4.15

Required C/N as a function of the power imbalance and the time delay of the two MISO signals and the same signal configuration when operated in SISO mode for the SDR receiver and DVB-T2 mode 32k 64QAM 2/3 GI 1/32 (from [Mo2013])

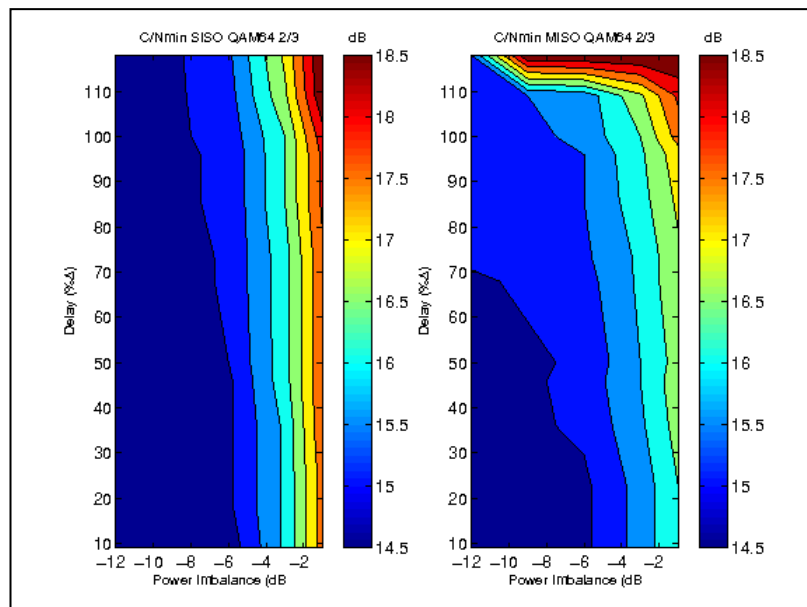

Because of the limited benefit of a MISO implementation for SFN coverage no proposal has been developed in this Report for how to incorporate MISO in a planning methodology or software tool.

4.4 Time-frequency slicing (TFS)

4.4.1 TFS in the DVB-T2 standard

Time-frequency slicing (TFS) is fully specified in the DVB-T2 standard, but has a less formal status. It is not a part of the “single profile” but is referred to as “for future implementations” in an informative annex. Full support for TFS could also be found in “surrounding” specifications such as “T2 delivery system descriptor” (Service Information) [EN 300 468] and the “T2 Modulator Interface specification (T2-MI)” [TS 102 773].

The reason why TFS has a less formal status is that it increases the cost of a receiver by requiring at least two tuners plus a special demodulator, and also that it requires several channels of DVB-T2 spectrum to switch between to achieve the intended gains.

4.4.2 The TFS concept

With TFS many statistically multiplexed services are transmitted over more than one RF channel; up to six may be used. Each service “jumps around” among the available frequencies.

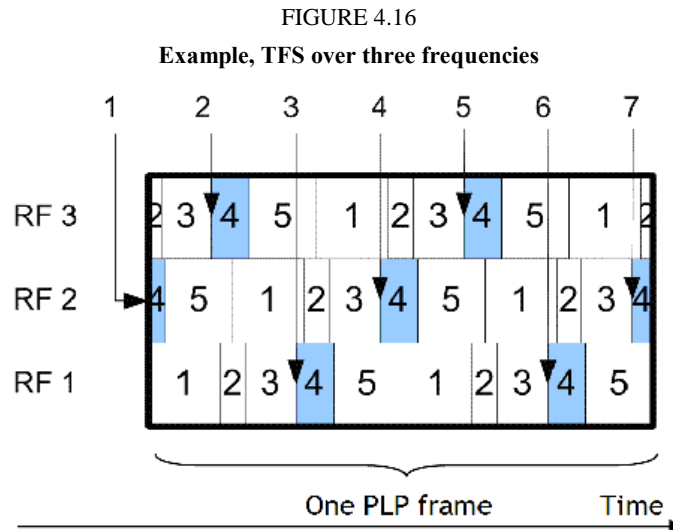

In Fig. 4.16 each physical layer pipe (PLP) is spread out over all (here 3) RF channels and over time. Each PLP is interleaved within the physical layer (PL) frame resulting in much improved time and frequency diversity.

With TFS it is possible to statistically multiplex over a significantly larger statistical multiplex pool than for a single multiplex. For example, in the case of six RF channels operating at 33 Mbit/s, 198 Mbit/s would be available compared with 33 Mbit/s available in a single RF channel. Statistical multiplexing with a pool of this size is almost ideal.

4.4.3 TFS gains

TFS allows for two independent gains:

Statistical multiplexing gain

- Large TS bit rate allows statmuxing of “many” services
- Allows more services to be transmitted
- Allows more stable video quality

Network planning gain

- Improved frequency diversity when each service is spread over several RF channels
- Improved link budget for “reception of all services”
- The improved link budget could allow for lower network costs and/or increased data rate
- A coherent reception of all services (PLPs with identical parameters)
- Improved robustness against time-varying channels and interference

Statistical multiplexing gain

It is a bit difficult to precisely estimate statmux gain. However, the gain can be presented as a percentage reduction of required bit rate or percentage increase in the number of services. But one has to be careful in how the gain figure is defined; a 50% reduction in required bit rate implies a 100% gain in number of services, see Fig. 4.17.

FIGURE 4.17
Statistical multiplex gain with MPEG-4 AVC

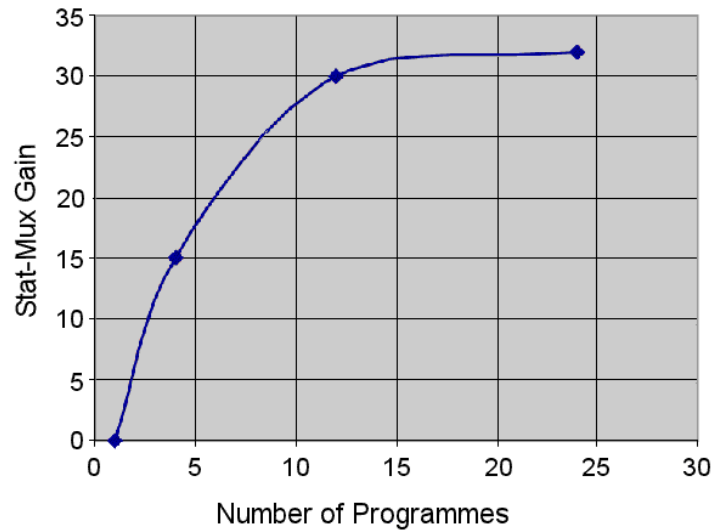

- 0% for 1 HD programme
- 15% for 3-4 HD programmes
- 30% for 9-12 HD programmes
- 32% for 18-24 HD programmes

Source: Thomson

The statmux gain could also be expressed as a virtual increase of bit rate and compared with statistical multiplexing within one RF channel (non-TFS):

3 RF channels: Virtual increase of bit rate = 21%

6 RF channels: Virtual increase of bit rate = 25%

Another feature is a more equal picture quality and the possibility of fine-tuning the bit rate per service.

Network planning gain

Without TFS the coverage of a set of multiplexes at a given location is limited by the multiplex with the lowest signal strength. With TFS the reception at a particular location is more likely to be determined by the average signal strength of the RF channels involved in TFS.

There are several components of the TFS network planning gain:

- TFS coverage gain
- TFS interference gain
- Improved robustness

4.4.4 TFS coverage gain

For a given equal ERP on multiple RF frequencies the received signal level, especially for fixed reception, varies significantly due to:

- Frequency-dependent transmitter antenna diagram
- Frequency-dependent terrain shielding (systematic)
- Frequency-dependent local variation (random)
- Frequency-dependent receiving antenna efficiency and gain (systematic and implementation dependent).

For each location, the TFS coverage gain could be expressed as the difference between the average signal strength and the minimum signal strength calculated over all RF frequencies at that particular location.

$$TFS \text{ coverage gain} = P(\text{average}) - P(\text{minimum}) \quad (\text{dB})$$

4.4.5 TFS interference gain

TFS improves the robustness against static and time-varying interference from other transmitters, since interference level varies with frequency. For example, one frequency could be completely lost due to temporary interference.

4.4.6 Improved robustness

TFS improves the robustness against channel time variations (similar to R_X diversity), especially important for portable/mobile reception.

4.4.7 Calculation of potential TFS coverage gain – example

The potential TFS coverage gain could be calculated based on field-strength measurements for a certain transmitter which transmits on more than one RF channel (multiplex).

In this example, the field measurements were performed for:

- Six transmitter sites (non SFN) with four multiplexes (frequencies) per site
- Equal ERP on all four frequencies
- About 40,000 measurements at a height of 3 m per measuring site
- Constant R_X antenna gain.

The measured TFS gain distribution is based on the received signal strength on each frequency. In Fig. 4.18 the measured distribution of TFS gain for six stations A-F is shown.

FIGURE 4.18
Measured distribution of TFS gain

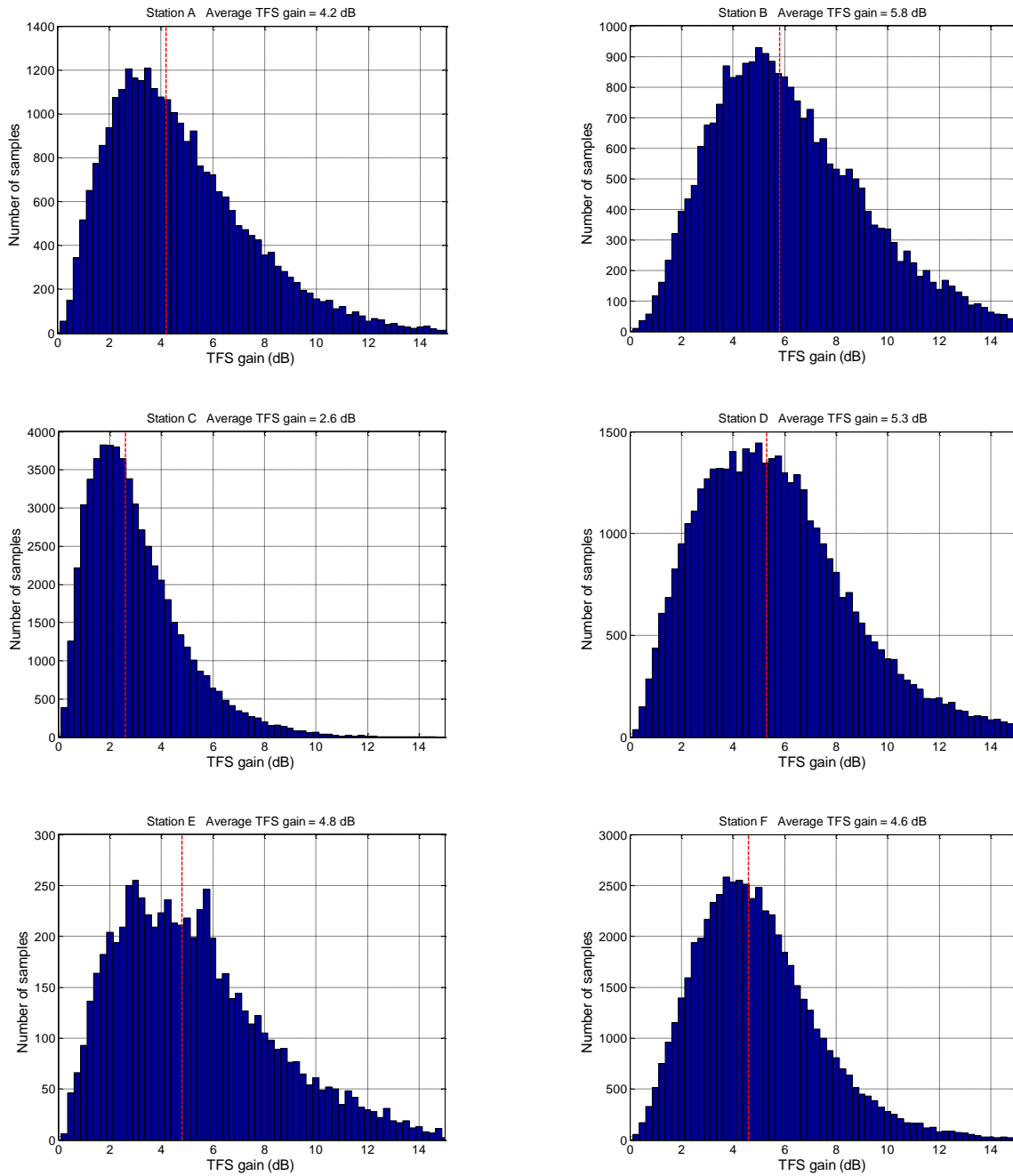

The measurements are performed at 3 m with an omnidirectional antenna. A summary is given in Table 4.4.

TABLE 4.4

Summary of measurement results at 3 m

Station	Average TFS signal gain	Number of measurements samples	Number of multiplexes	Channel number difference
A	4.2	27 000	4	16
B	5.8	30 000	4	34
C	2.6	58 000	4	15
D	5.3	41 000	4	32
E	4.8	6 000	4	24
F	4.6	56 000	4	26

The average TFS gain over all six areas is 4.5 dB.

4.4.8 Coherent coverage effects

In case each PLP has the same parameters, the coverage of all PLPs will be very similar, if not, identical.

A further aspect is the “common coverage shrinking”. TFS uses several RF channels at a time. If one RF channel fails (transmitter failure) the coverage will then shrink but not completely vanish. Only the outer part of the coverage is affected in that case. The more RF channels that are combined, the less is the loss of coverage when one channel fails.

4.5 Time slicing

The DVB-T2 specification allows for time slicing, which is a well-known DVB-H feature. Time slicing reduces the energy consumption of the receiving device. This is achieved by transmitting the services of a multiplex in time blocks which allows the receiver to demodulate the signal only for a certain fraction of time in order to receive a particular service. For the rest of the time the receiver may remain idle, it may use the remaining time for the check of other frequency blocks or channels.

4.6 Physical layer pipes

4.6.1 Input streams and physical layer pipes

The commercial requirement for service-specific robustness together with the need for different stream types is met by the concept of fully transparent PLPs. Both the allocated capacity and the robustness can be adjusted to the content/service providers’ particular needs, depending on the type of receiver and the receiving conditions to be addressed.

The DVB-T2 specification allows a constellation, code rate and time-interleaving depth to be assigned individually to each single PLP. A high level T2 block diagram is shown in Fig. 4.19.

Input streams are MPEG-2 transport streams (TS) or so called generic streams which could carry MPEG-2 or MPEG-4 video content. Each input stream is carried by a corresponding PLP in DVB-T2. A maximum of 255 input streams/PLPs could be transmitted with, typically, one service per TS/PLP.

A given MPEG-2 TS operates at constant bit rate (CBR) but it can contain payload with a variable bit rate (VBR) and “null packets” to make up the difference. TS packets which are null packets are, however, never transmitted. They are extracted before transmission and reinserted in the right places into the TS in the receiver; hence there is no null packet overhead in the transmission (transparent TS through the DVB-T2 system).

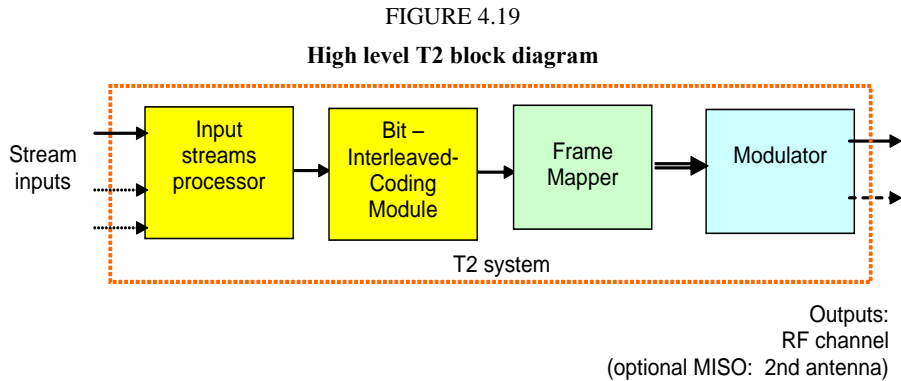

4.6.2 Single and multiple PLPs

There are two general input modes defined. Input mode A uses a single PLP, whilst input mode B uses multiple PLPs.

Input Mode A

This most simple mode can be viewed as a straightforward extension of DVB-T. Here the DVB-T2 signal uses only one single PLP transmitted over one frequency containing one MPEG-2 TS. Consequently the same robustness is applicable to all content, as in DVB-T.

Input Mode B

This more advanced mode of operation applies the concept of multiple PLPs (Fig. 4.20). In Mode B, one service is typically transmitted per PLP but a group of services (each with low bit rate) could also share one PLP.

Advantages with multiple PLPs are:

- Service-specific robustness (combination of modulation and code rate)
- Longer time-interleaving depth
- Allows for power saving in the receiver via time slicing as in DVB-H
- Allows for frequency diversity via time-frequency slicing (TFS).

Therefore even in the case of identical physical parameter settings, it might be useful to apply this mode, especially if portable and/or mobile devices are to be targeted.

FIGURE 4.20
T2 frame for single RF channel, multiple PLP mode (here, five PLPs)

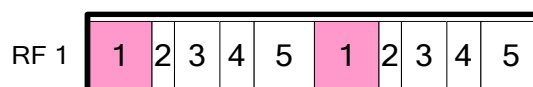

Typically a group of services will share common elements such as PSI/SI tables, like EPG information, or CA information. To avoid the need to duplicate this information for each PLP, Mode B offers the concept of common PLPs, shared by a group of PLPs. Hence, receivers need to decode up to two PLPs at the same time when receiving a single service: the data PLP and the common PLP.

FIGURE 4.21

Example of a DVB-T2 multiplex using PLP and carrying services with different data rates and different coverage radii

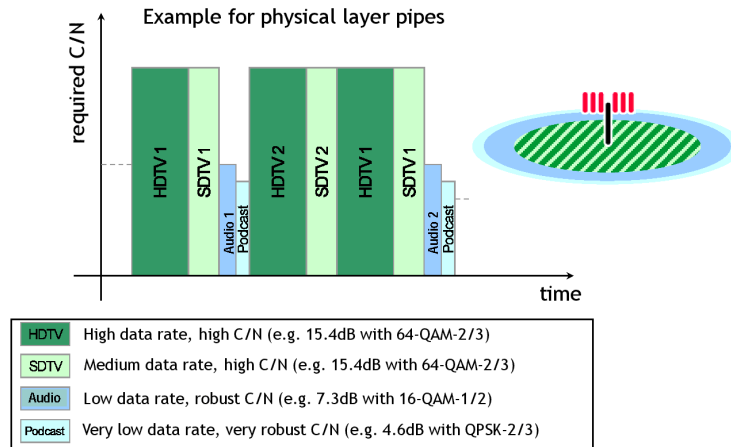

An example is given in Fig. 4.21 where four different classes of services (HDTV, SDTV, Audio Broadcasting and Data Broadcasting) are carried in one multiplex. Each of the services has a different data rate and a different coverage radius indicated in the Figure on the right hand side.

Additional advantages with multiple PLPs are:

- Different types of receivers and different reception cases could be addressed by the same signal, for example HDTV to fixed rooftop aerials and mobile receivers simultaneously, with a certain capacity and robustness for each category.
- One could prioritize the robustness for one or many services in one multiplex → prioritized services “last longer”.
- When one service in a multiplex does not need to have the same coverage as the other, that service could be transmitted with lower robustness saving transmission capacity.
- Simplifies the change to local/regional content (with constant bit rate) in a multiplex in which the rest of the content is centrally statistically multiplexed. The use of one dedicated PLP for local/regional content could result in an easier/cheaper implementation.
- When one wish to further increase the capacity and coverage by using the TFS concept.

One limitation with the use of PLPs is that it is not possible to have PLPs with different FFT sizes in the same multiplex. This could for example be a limitation when there is the need to provide rooftop reception for HD services and a mobile service in the same multiplex, using a large area SFN.

In order not to lose capacity there may then be a need to use the 32k FFT mode for the HD services. With the long symbol time it is possible to use a lower guard interval fraction, thus maximizing capacity. However if the 32k mode is used it will mean that the frequency distance between the OFDM carriers is short, which will make the mobile service sensitive to Doppler shift at higher speeds.

This limitation might be overcome by using the future extension frame (FEF), see § 4.8.

4.7 Peak-to-average power ratio (PAPR) reduction techniques

OFDM systems set high requirements on the linearity of the transmitter amplifiers. This fact reduces the power efficiency of OFDM systems remarkably. DVB-T2 offers two techniques for the reduction of the peak-to-average power ratio (PAPR), thus increasing the RF power-amplifier efficiency. These techniques are Active constellation extension (ACE) and Tone reservation (TR).

The following short description of these two techniques is taken from the Implementation Guideline [TR 102 831]. A more detailed description can be found in § 9.3.8 of the Implementation Guideline.

The ACE algorithm searches for the peaks in the OFDM signal and analyses the constellations to find out which data cells already contribute negatively to that peak. To intensify the effect of these cells their amplitude is increased, which is done by shifting the constellation points further out.

The basic idea of Tone reservation is that some carriers are reserved to reduce PAPR. These reserved carriers do not carry any data information and are instead filled with a peak-reduction signal. Because data and reserved carriers are allocated in disjointed subsets of subcarriers, Tone reservation needs no side information at the receiver other than an indication that the technique is in use, carried in the L1-pre signalling field “PAPR”.

It is possible to use both ACE and TR simultaneously; however, depending on the constellation, picking the better technique based on the constellation will provide most of the benefit. Both techniques come at a cost: ACE increases the noise level that the receiver sees while TR decreases throughput.

It should be noted that ACE cannot be applied when the rotated constellation mode (see § 2.6) is chosen.

4.8 Future extension frames (FEF)

DVB-T2 allows for the introduction of additional, as yet undefined or specified features by means of so-called Future extension frames (FEF). The Implementation Guideline [TR 102 831] describes this feature as follows:

FEF insertion enables carriage of frames defined in a future extension of the DVB-T2 standard in the same multiplex as regular T2-frames. The use of future extension frames is optional. A future extension frame may carry data in a way unknown to a DVB-T2 receiver addressing the current standard version. A receiver addressing the current standard version is not expected to decode future extension frames. All receivers are expected to detect FEF parts but ignore them for demodulation.

The only currently defined attributes of FEF parts, which are inserted between T2-frames (see Fig. 4.22), are that they begin with a P1 symbol and their positions in the superframe and duration in time are signalled in the L1 signalling in the T2-frames. This enables early receivers to ignore the FEFs whilst still receiving the T2 signal, as desired.

FIGURE 4.22
Co-existence of T2 frames and FEFs (from [TR 102 831])

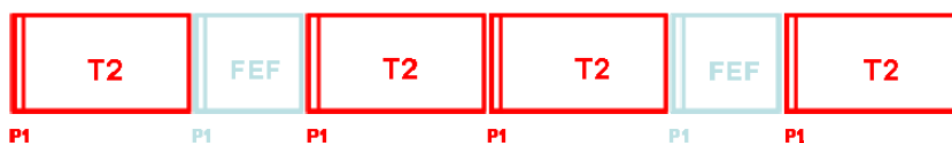

FEFs can be used for Transmitter Signatures [A150]. They allow measurements to identify which echo (path) in the channel impulse response originates from which transmitter of the SFN. It is also possible to display the parts of the channel impulse response originating from individual transmitters of the SFN.

FEFs could also be used, for example, for:

- Handheld services with MIMO support
- Upstream information for a DVB-T2 return channel
- Data transport of mobile service providers which use the same spectrum but have a different network structure.

An already existing application is the particular DVB-T2 profile T2-Lite which is described in Annex 5.

More details on FEF can be found in [TR 102 831, § 8.4].

5 Implementation scenarios

5.1 Introduction

DVB-T2 offers a significantly wider choice of parameters (which is described in § 2) than did DVB-T. The choice is so large that it is not possible to consider all of their possible combinations. This section considers a number of common applications of DVB-T2 and discusses some possible parameter sets which may be suitable for each of the scenarios.

Firstly, a number of scenarios appropriate to fixed roof-level reception are described. They comprise an MFN as well as an SFN approach and also reflect the need for a transition from DVB-T to DVB-T2, which is likely to be a common requirement.

Secondly, five scenarios particularly suited to portable and mobile DTT reception are described. All five scenarios are based on an SFN approach and include relatively large guard intervals to minimize intra-SFN interference and to allow greater transmitter separation. The 32k FFT mode is not applied for the same reason, since it is expected that this mode is particularly vulnerable to Doppler degradation and may be unsuitable for mobile and portable networks.

Parameters are based on the information given in the ETSI specification and Implementation Guideline [TS 102 831, EN 302 755]. C/N figures are derived according to the methodology described in § 2.5 and respective data rates according to Annex 2. In scenarios 1 and 4 the parameters of a corresponding DVB-T mode are also given for comparison. The C/N values for DVB-T are taken from the respective ETSI specification [EN 300 744], including an implementation margin of 3 dB.

With respect to version 2 of this report, some C/N figures are slightly changed due to the adaption of the Gaussian raw C/N reference figures in § 2.5 (Table 2.9).

5.2 Scenario 1: MFN rooftop reception and a transition case

A number of countries will wish to move from an established DVB-T network to one using DVB-T2. This scenario provides an example of how that transition might take place while incorporating some common practical considerations.

Although DVB-T2 may make it possible to improve or optimize the coverage of an existing network, in many cases the existing network's coverage would be considered sufficient and it would therefore be desirable to keep the coverage constant while increasing its capacity as that would allow new services to be introduced. In such situations, it would be desirable to reuse the existing infrastructure such as the transmission stations, transmitters, combiners and antenna systems. The example below

would allow this type of transition with a minimum of changes – essentially the only requirement being the upgrade of modulators. The transmission side of the network, otherwise unchanged, would maintain essentially constant coverage.³

For comparison, two sets of parameters are provided, one for the DVB-T network and another for the DVB-T2. Importantly, both sets of parameters result in a similar C/N , meaning that if the transmit antennas and powers of the DVB-T network are maintained for DVB-T2, the network's coverage would essentially remain unchanged. Both sets of parameters also exhibit the same guard interval duration despite the guard interval fraction being substantially reduced for the DVB-T2 case. Again, if the transmit antennas and radiated powers remained constant in both networks, the SFN timings of the DVB-T network would translate directly to the DVB-T2 network with little change in coverage.

DVB-T parameters		DVB-T2 parameters	
Bandwidth:	8 MHz	Bandwidth:	8 MHz
FFT size:	2k	FFT size:	32k
Carrier mode:	N/A	Carrier mode:	extended
Scattered pilot pattern:	N/A	Scattered pilot pattern:	PP7
Guard interval:	1/32 (7 μ s)	Guard interval:	1/128 (28 μ s)
Modulation:	64-QAM	Modulation:	256-QAM
Code rate:	2/3	Code rate:	2/3
C/N (Rice):	20.1 dB	C/N (Rice):	19.7 dB
Resulting data rate:	24.1 Mbit/s	Resulting data rate:	40.2 Mbit/s

5.3 Scenario 2: SFN rooftop reception, maximum coverage

This scenario is intended to maximize coverage in an SFN while providing rooftop reception. In this case it is necessary to use a relatively robust DVB-T2 mode. Several possible lengths of the guard interval may be possible depending on the network structure to be used, transmitter distance, radiated powers and terrain. Because of the relatively high robustness of the mode, it may be possible to reduce the guard interval to 1/16 (224 μ s) for very large SFNs – a change that would increase capacity.

Bandwidth:	8 MHz
FFT size:	32k
Carrier mode:	extended
Scattered pilot pattern:	PP2
Guard interval:	1/8 (448 μ s)
Modulation:	16-QAM
Code rate:	2/3
C/N (Rice):	11.6 dB
Resulting data rate:	16.7 Mbit/s

5.4 Scenario 3: SFN rooftop reception, moderate coverage

Generally two different choices of DVB-T2 parameter sets can be identified:

³ Changes to the distribution network and other similar details have not been considered.

- Where DVB-T2 is to replace an existing DVB-T SFN serving a moderately sized area, say up to a diameter of 100 km. This also seems to be a typically sized allotment area in the GE06 plan.
- Where there is a need to create a large area DVB-T2 SFN of “unlimited” size. In this case it would have been difficult to use DVB-T because of SFN self-interference.

Due to limited results from DVB-T2 field trials it may be too early to make a clear choice of code rate for the SFN case. There are two main candidates; code rates 3/5 and 2/3. The scenarios presented here are based upon the use of the 2/3 code rate, which gives higher capacity.

In these scenarios it is suggested that the 32k FFT size be used. It should be pointed out that 32k is mainly aimed at fixed rooftop reception due to its sensitivity to Doppler. It remains to be confirmed that the 32k modes are also suitable for portable indoor reception. This means that in cases where it is necessary to provide both rooftop *and* indoor reception the 16k modes may be more appropriate. This would result in the use of a higher GI fraction, and hence reduced capacity, to achieve the required guard interval duration.

5.4.1 Scenario 3a: Rooftop reception for limited area SFN

The selection of the guard interval in this scenario would be the same as the longest existing DVB-T mode (224 μ s), using 8k FFT. However in this case DVB-T2 will allow use of a lower GI fraction (1/16) in order to maximize the capacity, due to the availability of 32k FFT. The use of the “new” GI fraction 19/256 (266 μ s) could also be an option in some cases in order to improve the situation where there is SFN self-interference when using 1/16.

It should be pointed out that for the rooftop reception case, SFN self-interference effects may not be as large as in the mobile or portable cases where omnidirectional receiving antennas are used. This can possibly allow for a further reduction of the GI fraction to, for example, 1/32 (112 μ s) in some cases.

For large area SFNs it is in principle also possible to use the 19/128 (532 μ s) GI fraction but preliminary results show that a GI of 448 μ s is sufficient in order to avoid self-interference in “infinitely” large SFNs.

Bandwidth:	8 MHz
FFT size:	32k
Carrier mode:	extended
Scattered pilot pattern:	PP4
Guard interval:	1/16 (224 μ s)
Modulation:	256-QAM
Code rate:	2/3
<i>C/N</i> (Rice):	20.5 dB
Resulting data rate:	37.0 Mbit/s

5.4.2 Scenario 3b: Rooftop reception for large area SFNs

This parameter set would be used in cases where it is possible to create a large area SFN, for “nationwide coverage”. The GI fraction needs to be higher compared to the previous case in order to avoid SFN self-interference.

Bandwidth:	8 MHz
FFT size:	32k
Carrier mode:	extended
Scattered pilot pattern:	PP2
Guard interval:	1/8 (448 μ s)
Modulation:	256-QAM
Code rate:	2/3
<i>C/N</i> (Rice):	21.2 dB
Resulting data rate:	33.4 Mbit/s

5.5 Scenario 4: Portable reception (maximum data rate)

Scenario 4 describes a parameter set for portable reception. The parameters are adapted to the present DTT implementations based on DVB-T in Germany. They are designed for portable reception and are based on an SFN approach. The 16k mode is chosen with a guard interval length of 224 μ s. This allows for SFNs with a diameter of up to about 150 km.

DVB-T parameters		DVB-T2 parameters	
Bandwidth:	8 MHz	Bandwidth:	8 MHz
FFT mode:	8k	FFT mode:	16k
Carrier mode:	N/A	Carrier mode:	extended
Scattered pilot pattern:	N/A	Scattered pilot pattern:	PP3
Guard interval:	1/4 (224 μ s)	Guard interval:	1/8 (224 μ s)
Modulation:	16-QAM	Modulation:	64-QAM
Code rate:	2/3	Code rate:	2/3
<i>C/N</i> (Rayleigh):	17.2 dB	<i>C/N</i> (Rayleigh):	17.8 dB
Resulting data rate:	13.3 Mbit/s	Resulting data rate:	26.2 Mbit/s

Since the corresponding DVB-T implementation (8k, 16-QAM-2/3, GI 1/4) allows for a data rate of 13.3 Mbit/s, this DVB-T2 scenario roughly provides twice the data rate.

If it turns out that even the 32k mode were appropriate for portable reception, the following parameter set would be possible:

Bandwidth:	8 MHz
FFT mode:	32k
Carrier mode:	extended
Scattered pilot pattern:	PP4
Guard interval:	1/16 (224 μ s)
Modulation:	64-QAM
Code rate:	2/3
<i>C/N</i> (Rayleigh):	17.8 dB
Resulting data rate:	27.7 Mbit/s

However, the viability of the 32k mode for portable reception is still to be proven in field trials, whereas it is now apparent from field trials that this mode is not appropriate for mobile reception.

5.6 Scenario 5: Portable reception (maximum coverage area extension)

On the other hand, DVB-T2 may be used to extend an existing (DVB-T) coverage while keeping the (DVB-T) data rate. This can be achieved by applying a more rugged DVB-T2 system variant. An example scenario may be:

Bandwidth:	8 MHz
FFT mode:	16k
Carrier mode:	extended
Scattered pilot pattern:	PP3
Guard interval:	1/8 (224 μ s)
Modulation:	16-QAM
Code rate:	1/2
C/N (Rayleigh):	9.6 dB
Resulting data rate:	13.1 Mbit/s

As compared to the corresponding DVB-T implementation, a gain of about 7-8 dB is achieved. This may suffice to supply large parts of an area with portable reception where previously only fixed reception was possible, or to supply portable indoor reception where previously only portable outdoor reception was possible.

5.7 Scenario 6: Portable reception (optimal spectrum usage)

This scenario aims at an optimal spectrum usage in the sense that DTT service areas with the same MUX content are covered by one (possibly very large) SFN. For this purpose, a very large guard interval has to be chosen. This approach is best suited for national service areas; however, it has to be kept in mind that the present GE06 plan does not provide such large allotment areas. Thus, additional coordination is necessary to realize this scenario.

Bandwidth:	8 MHz
FFT mode:	16k
Carrier mode:	extended
Scattered pilot pattern:	PP1
Guard interval:	1/4 (448 μ s)
Modulation:	64-QAM
Code rate:	2/3
C/N (Rayleigh):	18.2 dB
Resulting data rate:	22.6 Mbit/s

As compared to scenario 4, the higher expected spectrum efficiency is paid for by a smaller data rate of about 22.6 Mbit/s.

5.8 Scenario 7: Mobile reception (1.7 MHz bandwidth in Band III)

DVB-T2 additionally provides an operation mode with 1.7 MHz bandwidth. This allows for an implementation compliant with the DAB frequency block structure of the GE06 Plan. In this way also audio and mobile TV (with low bit rate) services may be supported.

In the presented scenario a 4k mode is chosen which allows for a relatively high data rate. But as already encountered in a previous scenario the viability of an FFT mode with such a small carrier separation is still to be proven in field trials.

Bandwidth:	1.7 MHz
FFT mode:	4k
Carrier mode:	normal
Scattered pilot pattern:	PP2
Guard interval:	1/8 (278 μ s)
Modulation:	16-QAM
Code rate:	1/2
C/N (Rayleigh):	10.0 dB
Resulting data rate:	2.5 Mbit/s

A similar guard interval length to that of T-DAB is chosen in this scenario. Nonetheless, it can be expected that the SFN performance is worse for DVB-T2 since the degradation characteristics of DVB-T2 are more critical than those of T-DAB. Therefore, it might be necessary to choose a larger guard interval for the DVB-T2 scenario in order to allow for large SFN areas. A possible scenario for this could be:

Bandwidth:	1.7 MHz
FFT mode:	4k
Carrier mode:	normal
Scattered pilot pattern:	PP1
Guard interval:	1/4 (555 μ s)
Modulation:	16-QAM
Code rate:	1/2
C/N (Rayleigh):	10.0 dB
Resulting data rate:	2.2 Mbit/s

In the end, simulations and field trials are required to assess the appropriate guard interval for this scenario.

5.9 Scenario 8: Portable and mobile reception (common MUX usage by different services) – Multiple PLPs

This scenario describes a joint usage of a DVB-T2 multiplex by different services (high/low data rate, rugged/less rugged, etc.). A typical example could be audio/mobile TV on one hand and SD/HDTV on the other hand. This is possible in DVB-T2 because of its high flexibility with regard to the separate choice of modulation, code rate or time interleaving for each service. Restrictions have to be observed regarding the choice of the FFT mode and the scattered pilot pattern. These are common to all services and have therefore to be chosen appropriately.

Bandwidth:	8 MHz
FFT mode:	8k
Carrier mode:	Extended
Scattered pilot pattern:	PP1
Guard interval:	1/4 (224 μ s)
High data rate service (TV)	
Modulation:	64-QAM
Code rate:	2/3
C/N (Rayleigh):	18.2 dB
Maximum data rate:	22.4 Mbit/s (100% high data rate, 0% low data rate service)

Low data rate service (Audio/Mobile TV)	
Modulation:	16-QAM
Code rate:	1/2
C/N (Rayleigh):	10.0 dB
Maximum data rate:	11.2 Mbit/s (0% high data rate, 100% low data rate service)

A possible partitioning of the MUX could be:

1.5 Mbit/s for the low data rate service (13% of the MUX capacity)

19.4 Mbit/s for the high data rate service (87% of the MUX capacity)

The DVB-T2-Lite profile represents a particular realization of the concept of common MUX usage by different services. This is described in more detail in Annex 5.

5.10 Overview of scenarios

Tables 5.1 and 5.2 give an overview of the scenarios.

TABLE 5.1

Overview of the rooftop implementation scenarios

Implementation	Fixed rooftop reception MFN (UK mode)	Fixed rooftop reception (maximum coverage area extension)	Fixed rooftop reception Limited area SFN (GE06 Allotment)	Fixed rooftop reception Large area SFN
Scenario	1	2	3a	3b
Bandwidth	8 MHz	8 MHz	8 MHz	8 MHz
FFT mode	32k	32k	32k	32k
Carrier mode	Extended	Extended	Extended	Extended
Scattered pilot pattern	PP7	PP2	PP4	PP2
Guard interval	1/128 (28 μ s)	1/8 (448 μ s)	1/16 (224 μ s)	1/8 (448 μ s)
Modulation	256-QAM	16-QAM	256-QAM	256-QAM
Code rate	2/3	2/3	2/3	2/3
C/N	19.7 dB	11.6 dB	20.5 dB	20.9 dB
Data rate	40.2 Mbit/s	16.7 Mbit/s	37.0 Mbit/s	33.4 Mbit/s

TABLE 5.2

Overview of the portable and mobile implementation scenarios

Implementation	Portable reception (maximum data rate)	Portable reception (maximum data rate, alternative)	Portable reception (maximum coverage area extension)	Portable reception (optimum spectrum usage)	Mobile reception Band III	Mobile reception Band III (alternative)	Portable and mobile reception (common usage of MUX by different services)	
Scenario	4a	4b	5	6	7a	7b	8 high data rate low data rate	
Bandwidth	8 MHz	8 MHz	8 MHz	8 MHz	1.7 MHz	1.7 MHz	8 MHz	
FFT mode	16k	32k	16k	16k	4k	4k	8k	
Carrier mode	Extended	Extended	Extended	Extended	Normal	Normal	Extended	
Scattered pilot pattern	PP3	PP4	PP3	PP1	PP2	PP1	PP1	
Guard interval	1/8 (224 μ s)	1/16 (224 μ s)	1/8 (224 μ s)	1/4 (448 μ s)	1/8 (278 μ s)	1/4 (555 μ s)	1/4 (224 μ s)	
Modulation	64-QAM	64-QAM	16-QAM	64-QAM	16-QAM	16-QAM	64-QAM	16-QAM
Code rate	2/3	2/3	1/2	2/3	1/2	1/2	2/3	1/2
C/N	17.8 dB	17.8 dB	9.6 dB	18.2 dB	10.0 dB	10.0 dB	18.2 dB	10.0 dB
Data rate	26.2 Mbit/s	27.7 Mbit/s	13.1 Mbit/s	22.6 Mbit/s	2.5 Mbit/s	2.2 Mbit/s	22.4 Mbit/s (max)	11.2 Mbit/s (max)

6 Transition to DVB-T2

6.1 DVB-T2 in GE06

6.1.1 Implementing alternative broadcasting transmission systems under the GE06 Agreement

The RRC-06 adopted DVB-T and T-DAB as the two transmission systems for which the GE06 Plan was developed. Contracting Members of the GE06 Agreement [RRC06] adopted these two transmission systems as the only transmission systems for modifying the Plan and their Plan entries. Furthermore, the Plan modification procedures of Article 4 have been developed specifically in terms of these two transmission systems. The result is that only these two transmission systems can be used when submitting modifications to the Plan. This implies that if a Contracting Member of the GE06 Agreement wants to implement assignments using DVB-T2 or another transmission system, then such assignments must first be submitted as Plan modifications using suitable technical characteristics and either indicating T-DAB or DVB-T as the transmission system.

When the Plan entry is brought into operation the administration can notify the actual transmission system (e.g. DVB-T2, DVB-H or any other suitable system) under the Article 5 provision 5.1.3 of the agreement. Under this provision such an implementation is restricted not to cause more interference or require a higher level of protection than the original Plan entry. Additionally, the peak power density over any 4 kHz of such an implementation should not exceed the peak power density in the same 4 kHz of the corresponding digital broadcasting Plan entry.

The ITU-R has prepared the notice form GB1 [CR262] for the notification of a DVB-T2 assignment.

6.1.2 Requirements for the development of the DVB-T2 specification

It was felt essential that DVB-T2 implementations should be able to use DVB-T assignments and allotments of the GE06 Plan in order to avoid re-planning activities and therefore adding complexity to the introduction of DVB-T2. The commercial requirements for the development of the DVB-T2 specification therefore include the following: *“Transmissions using the DVB-T2 specification shall meet the interference levels and spectrum mask requirements as defined by GE06 and not cause more interference than DVB-T would do.”*

With respect to DVB-T as planned in the GE06 Plan, DVB-T2:

- offers the same or better protection ratios and comparable minimum median field strength values for suitable equivalent variants;
- can use the same linear (single or mixed) polarization of the digital broadcasting Plan entry;
- can realize the same service areas using the same or lower radiated power levels;
- maintains the same or lower peak power densities for variants operating in the same bandwidth and having the same or higher number of OFDM carriers (FFT size) for the same levels of radiated power.

6.1.3 Implementation of DVB-T2 in the GE06 Plan

DVB-T2 offers sufficient flexibility in terms of the number of suitable equivalent variants that would maintain the same service area and would permit the operation of an assignment(s) within the limitations of Provision 5.1.3 of the GE06 Agreement and a corresponding digital broadcasting Plan entry. Additionally, in order to ensure that a DVB-T2 implementation respects the radiated power limitations outside the operating bandwidth, the DVB-T2 implementation will have to conform with the spectrum mask of the corresponding GE06 Plan entry as given in the GE06 Agreement in Fig. 3-2 and Table 3-10 (of the Agreement text) for T-DAB Plan entries and Fig. 3-3 and Table 3-11 for DVB-T Plan entries. Furthermore, the technical characteristics of the DVB-T2 implementation should be such

that it would receive a favourable finding when examining it under Section II of Annex 4 to the GE06 Agreement, along with Rule of Procedure Part A10/GE06 5.1.3, decisions 1 to 3 for conformity with respect to the corresponding Plan entry. DVB-T2 implementations that are in conformity with the relevant digital Plan entry and that have received a favourable finding will be recorded in the MIFR.

There remains a certain ambiguity with respect to the implementation of certain DVB-T2 variants and/or modes, for example, extended carrier mode and additional bandwidths. Recommendation ITU-R BT.1877 [BT1877] indicates that the 7 MHz and 8 MHz channel variants of DVB-T2 are compatible with the GE06 Plan for digital television broadcasting and the 1.7 MHz channel variant is compatible with T-DAB frequency planning. However, the DVB-T2 7 MHz extended carrier modes are not compatible with a DVB-T 7 MHz Plan entry if the required occupied bandwidth is compared with the GE06 DVB-T spectrum mask for 7 MHz. Similarly, the variants with a 1k FFT for 7 and 8 MHz channels would be affected in a similar manner if the relevant filter GE06 DVB-T mask is applied. DVB-T2 variants for 5 and 6 MHz channel arrangements may also be considered for the implementation of a GE06 Plan entry if suitable filtering is applied, however variants for these channel arrangements do not yet have defined spectrum shaping limits in the ETSI specification [EN 302 755] or in Recommendation ITU-R BT.1877 [BT1877].

Based on these considerations, DVB-T2 variants which are directly compatible with GE06 are listed in Tables 6.1 to 6.3 (noting that the other above-mentioned restrictions would need to be observed as well):

TABLE 6.1

DVB-T2 variants directly compatible with 7 MHz channel arrangements

Modulation	FFT size	Code rate*	Guard interval
QPSK or 16-QAM or 64-QAM or 256-QAM	2k	1/2, 3/5, 2/3, 3/4, 4/5, 5/6	1/32, 1/16, 1/8, 1/4
	4k	1/2, 3/5, 2/3, 3/4, 4/5, 5/6	1/32, 1/16, 1/8, 1/4
	8k	1/2, 3/5, 2/3, 3/4, 4/5, 5/6	1/128, 1/32, 1/16, 19/256, 1/8, 19/128, 1/4
	16k	1/2, 3/5, 2/3, 3/4, 4/5, 5/6	1/128, 1/32, 1/16, 19/256, 1/8, 19/128, 1/4
	32k	1/2, 3/5, 2/3, 3/4, 4/5, 5/6	1/128, 1/32, 1/16, 19/256, 1/8, 19/128

* For block sizes of 16,200 and 64,800 bits.

TABLE 6.2

DVB-T2 variants directly compatible with 8 MHz channel arrangements

Modulation	FFT size	Code rate*	Guard interval
QPSK or 16-QAM or 64-QAM or 256-QAM	2k	1/2, 3/5, 2/3, 3/4, 4/5, 5/6	1/32, 1/16, 1/8, 1/4
	4k	1/2, 3/5, 2/3, 3/4, 4/5, 5/6	1/32, 1/16, 1/8, 1/4
	8k	1/2, 3/5, 2/3, 3/4, 4/5, 5/6	1/128, 1/32, 1/16, 19/256, 1/8, 19/128, 1/4
	16k	1/2, 3/5, 2/3, 3/4, 4/5, 5/6	1/128, 1/32, 1/16, 19/256, 1/8, 19/128, 1/4
	32k	1/2, 3/5, 2/3, 3/4, 4/5, 5/6	1/128, 1/32, 1/16, 19/256, 1/8, 19/128
	8k extended	1/2, 3/5, 2/3, 3/4, 4/5, 5/6	1/128, 1/32, 1/16, 19/256, 1/8, 19/128, 1/4
	16k extended	1/2, 3/5, 2/3, 3/4, 4/5, 5/6	1/128, 1/32, 1/16, 19/256, 1/8, 19/128, 1/4
	32k extended	1/2, 3/5, 2/3, 3/4, 4/5, 5/6	1/128, 1/32, 1/16, 19/256, 1/8, 19/128

* For block sizes of 16,200 and 64,800 bits.

TABLE 6.3

DVB-T2 variants directly compatible with 1.7 MHz channel arrangements

Modulation	FFT size	Code rate*	Guard interval
QPSK or 16-QAM or 64-QAM or 256-QAM	1k	1/2, 3/5, 2/3, 3/4, 4/5, 5/6	1/16, 1/8, 1/4
	2k	1/2, 3/5, 2/3, 3/4, 4/5, 5/6	1/32, 1/16, 1/8, 1/4
	4k	1/2, 3/5, 2/3, 3/4, 4/5, 5/6	1/32, 1/16, 1/8, 1/4
	8k	1/2, 3/5, 2/3, 3/4, 4/5, 5/6	1/128, 1/32, 1/16, 19/256, 1/8, 19/128, 1/4

* For block sizes of 16,200 and 64,800 bits.

It is however important to note that if suitable filtering is applied, all DVB-T2 variant RF signals can be made compatible with the corresponding spectrum mask of the GE06 Agreement. In a similar manner filtering is also applied on a baseband and/or RF level in the case of DVB-T transmissions. No spectrum mask has been defined for DVB-T2 (in contrast to DVB-T) in Recommendation ITU-R BT.1877 [BT1877] or in the ETSI specification [EN 302 755], since, as stated in § 6.1.2, it is assumed that DVB-T2 transmissions will need to fulfil the same spectrum mask as has been defined for DVB-T. The spectral characteristics of the transmitted signal are a function of the natural OFDM signal, additional digital filtering, transmitter non-linearity and analogue RF-filtering. It is therefore possible to use a DVB-T2 mode which has a natural spectrum that is “incompatible” with the GE06 spectrum mask as long as the additional steps of the processing chain before emission ensure that the transmitted spectrum does indeed fulfil the GE06 spectrum mask.

Thus, in terms of their interference potential, all DVB-T2 1.7 MHz, 7 MHz and 8 MHz system variants (including all FFT sizes as well as normal or extended bandwidth, where applicable) could be used as long as the GE06 spectrum masks and other GE06 constraints are fulfilled for the transmitted signal. It should be noted that there may exist unconventional but commercially relevant cases where, for example, an 8 MHz signal could be transmitted in a 7 MHz Plan entry, but with additional filtering to ensure that the transmitted signal conforms to the GE06 spectrum mask.

These operational aspects are not however part of a formal Plan modification or notification procedure in the GE06 Agreement and such filtering will result in changing the technical characteristics of the DVB-T2 implementation (e.g. *C/N* ratios, protection ratios and required minimum median field strength values) from that of the standard specific DVB-T2 variant that has been filtered only to its necessary occupied bandwidth. This renders such implementations difficult to apply by administrations when they are recorded in the MIFR and their required level of protection is to be established in the case that harmful interference could occur to these implementations, where these assignments can only claim protection to the level afforded by the corresponding Plan entry.

6.2 Transition scenarios

6.2.1 Introduction

When moving from analogue to digital transmissions broadcasters have gained experience with the transition from one system to another. Some of the lessons learned were:

- the higher the percentage of viewers that depend on the terrestrial platform as compared to other platforms, the more difficult and lengthy is the transition period;
- for a certain period, a parallel operation of the old and the new technique is required;
- a certain amount of additional spectrum is needed for this, to accomplish the transition to new and more efficient techniques;

- an incentive in terms of additional programmes, higher service quality, etc. is required for viewers to accept the transition to new techniques because it may imply an upgrade of the user equipment, which they will have to pay for.

Some of these aspects are addressed further in this section as far as general considerations on the transition to DVB-T2 are concerned. Aspects particular to individual countries are described in Annex 7.

6.2.2 Infrastructure

For DVB-T2 the existing infrastructure (from analogue TV or DVB-T) which is related to antennas, masts, amplifiers, repeaters (although not re-transmitters which re-generate the signal), etc. at the transmitting side can often be retained. On the receiver side existing antennas can also be re-used.

Since DVB-T2 is not downward compatible with DVB-T new tuners, i.e. new TV sets or at least additional set-top boxes are required at the receiving side. Accordingly, modulators, gateways in the case of SFNs, upgrade of the contribution network, monitoring equipment and possibly filters are required at the transmitting side. In addition, the operation modus of relays which are fed off-air may have to be changed with the migration to DVB-T2.

Most probably, also MPEG-4 source coding will then be used, although this aspect does not affect the RF transmission/reception side.

6.2.3 Frequency planning issues

The commercial requirements for DVB-T2 foresee compatibility with the GE06 Plan as a matter of principle. Therefore it is possible to use the existing GE06 Plan assignments and/or allotments for the implementation of DVB-T2. The preceding § 6.1 showed that there certain constraints have to be taken into account.

From a frequency planning point of view, for the transition to DVB-T2, it is therefore the easiest way to use the existing GE06 Plan structure. No additional frequency re-planning is required in this case, neither on national nor on international level. It implies that the same characteristics with regard to transmitter power, antenna position and diagram, etc. are used. A gain in data capacity and/or coverage quality is achieved. Similarly, for an allotment implementation the characteristics of the allotment plan entry regarding its interference potential should be kept while achieving a gain in data capacity and/or coverage quality.

But DVB-T2 would, in principle, also allow for a more radical approach with regard to frequency and network planning resulting in even higher spectrum efficiency. For DVB-T it is well known that the size of SFN is restricted because of self-interference effects. This restriction is reduced with DVB-T2 because of the larger guard intervals coming along with higher FFT modes. In a similar manner, existing coverage concepts (with regard to data capacity and reception mode) could be realized with less transmitter sites and/or frequency assignments.

But such approaches would imply a major re-arrangement of the existing frequency plan which is best achieved by a new planning conference. At present, such a general re-design of the existing frequency plan is not regarded as feasible. However, some improvements may be achieved by national or bilateral re-arrangements. An example for the latter is the aggregation of several national co-channel allotments to one large allotment in order to increase the coverage area which becomes technically possible with the new DVB-T2 variants; although then some multiplex capacity is lost.

6.2.4 Transition from Analogue TV to DVB-T2

For countries that have not yet started their transition to DTT, it seems logical that they should immediately introduce DVB-T2. Since DVB-T2 has already started as a regular service in some

countries DVB-T2 equipment is now available on a mass market, and is often now incorporated in TV sets and PVRs.

It is expected that a simulcast period similar to that required for the transition from analogue TV to DVB-T will be needed for transitions where DVB-T is already in operation. The length of the simulcast period will depend on how rapidly viewers with DVB-T only equipment can upgrade to DVB-T2 compatible receivers.

For the simulcast period, additional spectrum would be required for the parallel transmission of TV services. The required amount of spectrum will heavily depend on the introduction strategy adopted for DVB-T2. For example in Spain, with a high percentage of the population using the terrestrial platform as their main means of reception, additional available spectrum was used for the simulcast period.

A short simulcast period will reduce transition costs, and where possible a region-wise transition may avoid too abrupt changes across the whole country. This approach was taken by Germany with the introduction of DTT, based on the fact that the percentage of the terrestrial platform was relatively small.

The simulcast situation is eased with a transition from analogue to DVB-T2 as this technology can accommodate more individual programmes in a multiplex and so a smaller number of multiplexes may be required. This will alleviate the cost of the simulcast period and the difficulty of finding spectrum for the simulcast.

6.2.5 Transition from DVB-T to DVB-T2

Many European countries have already introduced DVB-T and have, or are about to cease analogue transmissions. For them a migration to DVB-T2 is a possible next step in the development and implementation of broadcast delivery technologies.

DVB-T2 is not backwards compatible with DVB-T, so an abrupt migration from DVB-T to DVB-T2 is not possible. More sophisticated migration strategies are required. It is a commonly held view that this migration should be based on there being additional offers to the consumer in order to be successful. These offers may consist of additional programmes or may consist of different service types, such as HDTV.

In general therefore, for the migration period, unused and/or additional spectrum is required. This may be found in temporarily unused spectrum, available perhaps in countries where DVB-H is regarded as not being successful. Other countries may use available VHF spectrum for this purpose. A further possibility may be the more compact aggregation of DVB-T programmes in existing multiplexes (with a possible slight loss of quality) in order to free spectrum for an additional DVB-T2 multiplex. In exceptional cases the switch-off of DVB-T programmes may also be considered in order to free up spectrum for a DVB-T2 multiplex.

Some broadcasters may choose the enlarged possibilities of DVB-T2 to change or extend their coverage and/or service concept. For example, a change from a coverage which up to now mainly provides fixed reception to portable outdoor/mobile reception is possible. Also the provision of a better video quality is possible.

For countries that have already switched to DTT the issue of consumer reinvestment becomes an issue. The introduction of DVB-T, perhaps within the last ten years, was accompanied by the need for consumers to invest in new receiving equipment. Now, with the migration to DVB-T2, a new investment in receiving equipment is required by the consumers. This is a difficult situation since consumers have been used to longer renewal cycles of TV receiving equipment. The introductory strategy for DVB-T2 has to be chosen carefully in order not to lose customers to other platforms, as happened in some countries with the transition from Analogue TV to DVB-T.

A special situation arises in countries that have started but not completed the process of digital switch-over⁴ from Analogue TV to DVB-T and that also start to introduce DVB-T2. This situation is not that uncommon. Countries where the terrestrial platform is used by a large percentage of the population as the primary means of reception will necessarily have a long transition period and they are now faced with the challenge of an additional migration. Special considerations have then to be applied. A particular case is described in detail in Annex 7 for the United Kingdom.

7 References

- [A122] DVB BlueBook A122 Rev.1, “Frame structure channel coding and modulation for a second generation digital terrestrial television broadcasting system (DVB-T2)”, DVB, January 2008.
- [A133] DVB BlueBook A133, “Implementation guidelines for a second generation digital terrestrial television broadcasting system (DVB-T2)”, DVB, February 2009.
- [A150] DVB Doc. A 150, “Structure and modulation of optional transmitter signatures (T2-TX-SIG) for use with the DVB-T2”, DVB, June 2010.
- [AFM2010] AFM-Report (ARD/ZDF), “Rundfunkrelevante Aspekte der Funkübertragungssysteme DVB-T2 und LTE“, ARD/ZDF, April 2010.
- [BCP078] EBU Doc. B/BCP 078, “Man-Made Noise in the VHF- and UHF-Frequency Band: Results of Indoor Measurements”, Contribution from IRT, EBU, Geneva, 2005.
- [BG2009] Brugger, R., Gbenga-Ilori, A., “Spectrum usage and requirements for future terrestrial broadcast applications” EBU Tech. Rev. 4/2009, EBU, Geneva, 2009.
- [BH2003] Brugger, R., Hemmingway, D., “OFDM receivers – impact on coverage of inter-symbol interference and FFT window positioning”, EBU Tech.Rev. 295, EBU, Geneva, 2003.
- [BPN005] EBU BPN005 3rd issue, “Terrestrial Digital Television – Planning and Implementation Considerations”, EBU, Geneva, 2001.
- [CPRT008] EBU Doc. CPRT 008 Rev1, “Proposed revision of planning criteria and parameter values given in EBU documents”, EBU, Geneva, 2004.
- [CR262] ITU-R, Circular Letter CR 262 of 11-06-2006, + Addendum 1 of 03-10-2007, + Addendum 2 of 28-07-2008, ITU, Geneva, 2006-2008.
- [ECC148] CEPT ECC Report 148, “Measurements on the performance of DVB-T receivers in the presence of interference from the mobile service (especially from LTE)”, CEPT, Copenhagen, 2010.
- [ECC049] CEPT ECC Report 049, Annex 3, “Planning Configurations and Reference Networks for DVB-T”, CEPT, Copenhagen, 2004.
- [EDP089] EBU Doc. ECS-EDP 089, “Symbol length and degradation beyond guard interval”, Contribution from IRT, EBU, Geneva, 2010.
- [EDP135] EBU Doc. SM-EDP 135, “DVB-T2 THRESHOLDS- DATA FROM FIELD TRIALS”, contribution from University of the Basque Country (UPV/EHU), EBU, Geneva, 2011 also: Eizmendi, I, *et al.*, CNR requirements for DVB-T2 fixed reception based on field trial results, Electronics Letters Volume: 47 Issue: 1, Jan. 2011.
- [EDP166] EBU Doc. SM-EDP 166, “C/N Measurements of DVB-T2 Receivers”, Contribution from IRT, EBU, Geneva, 2011.

⁴ The term “digital switch-over” is defined as “The transition of a radiocommunication broadcasting service from analogue to digital technology.

NOTE – This term is merely and specifically relevant to broadcasting”.

- [EDP247] EBU Doc. SM-EDP 247, “DVB-T2 C/N measurements”, Contribution from IRT, EBU, Geneva, 2012.
- [Ei2010] Eizmendi, I., *et al.*, HDTV field trials using DVB-T and DVB-T2 broadcasting systems, 2010 IEEE International Symposium on Broadband Multimedia Systems and Broadcasting (BMSB).
- [Ei2011] Eizmendi, I., PhD Thesis, Study of Minimum Requirements for DVB-T2 Digital Terrestrial System Fixed Reception, (in Spanish: Estudio de Requisitos Mínimos para la Recepción Fija del Sistema de Televisión Digital Terrestre DVB-T2). December 2011.
- [EN 300 744] ETSI EN 300 744 V1.6.1 (2009-01), “Digital Video Broadcasting (DVB); Framing structure, channel coding and modulation for digital terrestrial television”, ETSI, Sophia Antipolis, 2009.
- [EN 300 468] ETSI EN 300 468 V1.11.1 (2010-04), Digital Video Broadcasting (DVB); Specification for Service Information (SI) in DVB systems, ETSI, Sophia Antipolis, 2010.
- [EN 302 755] ETSI EN 302 755 V1.2.1 (2011-02), “Digital Video Broadcasting (DVB); Frame structure channel coding and modulation for a second generation digital terrestrial television broadcasting system (DVB-T2)”, ETSI, Sophia Antipolis, 2011.
- [EN 302 755-V1.3.1] ETSI EN 302 755 V1.3.1 (2011-11), “Digital Video Broadcasting (DVB); Frame structure channel coding and modulation for a second generation digital terrestrial television broadcasting system (DVB-T2)”, ETSI, Sophia Antipolis, 2011.
- [F2010] Fischer, W., “Digital Video and Audio Broadcasting Technology: A Practical Engineering Guide”, Springer, Berlin, 2010.
- [IEC 62216] IEC 62216 ed1.0, “Digital terrestrial television receivers for the DVB-T system”, IEC, 2009.
- [IRT2011] Beier, A., IRT, private communication, 2011.
- [KHM1998] Kostanic, I., *et al.*, “Measurements of the vehicle penetration loss characteristics at 800 MHz”, Vehicular Technology Conference, 1998. VTC 98. pp. 1-4, IEEE, 1998.
- [Mo2013] Morgade, J., *et al.*, “SFN-SISO and SFN-MISO gain performance analysis for DVB-T2 network planning”, IEEE Transactions on Broadcasting, vol. 60, No. 2, 2014, Part I: Special Issue on the Future of Broadcast Television Initiative, pp. 272-286.
- [ND2007] Nour, C.A., Douillard, C., “Doubled diversity BICM schemes suitable for the DVB-T2 baseline”, ENST Bretagne, 2007.
- [ND2008] Nour, C.A., Douillard, C., “Rotated-QAM Constellations to Improve BICM Performance for DVB-T2”, IEEE 10th Int. Symp. On Spread Spectrum Techniques and Applications, ISSSTA’08, p. 354, Bologna, 2008.
- [Nord2012] Projektrat DVB-T2 Modellversuch Norddeutschland, “Terrestrik der Zukunft – Zukunft der Terrestrik”, Aachen, 2012.
- [NorDig2013] NorDig Unified Requirements for Integrated Receiver Decoders for use in cable, satellite, terrestrial and IP-based networks, NorDig Std. NorDig Unified ver 2.4, Jan. 2013.
- [NTIA02-390] Achatz, R.J., Dalke, R.A., “Man-Made Noise Power Measurements at VHF and UHF Frequencies”, NTIA Report 02 390, Boulder, December 2001.
- [Po2001] Poole, R., “The Echo Performance of DVB-T Receivers” EBU Tech Rev. 288, EBU, Geneva, 2001.
- [Po2005] Poole, R., “Digital television services: Equivalent noise floors and equivalent noise degradation,” BBC R&D, White Paper WHP 105, January, 2005.

- [RA2000] Radiocommunications Agency, “DVB-T Domestic Receiver Performance Measurements with a Single Echo, An RTCG Project Report”, February 2000.
- [RRC06] RRC-06, “Final Acts of the Regional Radiocommunication Conference RRC-06”, ITU-R, Geneva, 2006.
- [Tech3317] EBU Tech 3317, “Planning parameters for hand-held reception”, EBU, Geneva, 2007.
- [TR 102 377] ETSI TR 102 377 V1.2.2 (2006-01), “Digital Video Broadcasting (DVB); DVB-H Implementation Guidelines”, ETSI, Sophia Antipolis, 2006.
- [TS 102 773] ETSI TS 102 773 V1.3.1 (2012-01), “Digital Video Broadcasting (DVB); Modulator Interface (T2-MI) for a second generation digital terrestrial television broadcasting system (DVB-T2)”, ETSI, Sophia Antipolis, 2012.
- [TS 102 831] ETSI TS 102 831 V1.2.1 (2012-08), “Digital Video Broadcasting (DVB); Implementation guidelines for a second generation digital terrestrial television broadcasting system (DVB-T2)”, ETSI, Sophia Antipolis, 2012.

Annex 1

Planning methods, criteria and parameter

A1.1 Reception modes

A1.1.1 Fixed antenna reception

Fixed antenna reception is defined as:

Reception where a directional receiving antenna mounted at roof-level is used. In calculating the equivalent field strength required for fixed antenna reception, a receiving antenna height of 10 m above ground level is considered to be representative.

A1.1.2 Portable antenna reception

In the context of this document, portable reception is defined as the reception at rest (stationary reception) or at very low speed (walking speed). Portable reception will, in practice, take place under a great variety of conditions (outdoor, indoor, ground floor and upper floors). In this document, portable reception is comprised of two classes:

- Class A: portable outdoor reception
 - i) with external (for example telescopic or wired headsets) or integrated antenna;
 - ii) at no less than 1.5 m above ground level, at very low speed or at rest.
- Class B: portable indoor reception
 - i) with external (for example telescopic or wired headsets) or integrated antenna;
 - ii) at no less than 1.5 m above ground level, at very low speed or at rest;
 - iii) on the ground floor in a room with a window in an external wall.

It is assumed that the portable receiver is not moved during reception and that large objects near the receiver are also not moved. This does not mean that the transmission channel is static; rather, a slowly time-varying channel is assumed. It is also understood that extreme cases, such as reception in completely shielded rooms, be disregarded.

A1.1.3 Mobile reception

Mobile reception is defined as the reception of a DVB-T2 signal by a receiver in motion with an antenna situated at no less than 1.5 m above ground level. The term motion covers speeds from a walking person to a car driven on a motorway. High-speed trains, buses and other vehicles could be considered in some countries.

A1.1.4 Handheld reception

A1.1.4.1 Handheld portable reception

In the context of this document, handheld portable reception is defined as the reception at rest (stationary reception) or at very low speed (walking speed). Handheld portable reception will, in practice, take place under a great variety of conditions (outdoor, indoor, ground floor and upper floors). In addition, the handheld receiver will probably be moved (at walking speed) while being viewed.

The difference between portable reception and handheld portable reception lies in the different antenna gains which are assumed for the two reception modes.

In this document, handheld portable reception is comprised of two classes:

- Class H-A: handheld portable outdoor reception
 - i) with external (for example telescopic or wired headsets) or integrated antenna;
 - ii) at no less than 1.5 m above ground level, at very low speed or at rest.
- Class H-B: handheld portable indoor reception
 - i) with external (for example telescopic or wired headsets) or integrated antenna;
 - ii) at no less than 1.5 m above ground level, at very low speed or at rest;
 - iii) on the ground floor in a room with a window in an external wall.

It is assumed that the handheld portable receiver is not moved during reception and that large objects near the receiver are also not moved. This does not mean that the transmission channel is static; rather, a slowly time-varying channel is assumed. It is also understood that extreme cases, such as reception in completely shielded rooms, be disregarded.

For the handheld reception mode, it is often possible to improve reception by moving the receiver position and/or by using an antenna with higher efficiency.

It is to be expected that there will be significant variation of reception conditions for indoor portable reception, also depending on the floor-level at which reception is required. There will also be considerable variation of building penetration loss from one building to another and considerable variation from one part of a room to another. Also, handheld receivers could suffer from body-absorption/reflection loss in certain circumstances, e.g. file-downloading applications when the receiver is in a pocket. It is to be expected that “portable coverage” will be mainly aimed at urban and suburban areas.

A1.1.4.2 Handheld mobile reception

In the context of this document, handheld mobile reception is comprised of two classes:

- Class H-C: handheld reception inside a moving vehicle (car, bus, etc.)
 - i) with the receiver connected to the external antenna of the vehicle;
 - ii) at no less than 1.5 m above ground level, at higher speed.
- Class H-D: handheld reception inside a moving vehicle (e.g. car, bus, etc.)
 - i) without connexion of the receiver to the external antenna of the vehicle;

- ii) with external (for example telescopic or wired headsets) or integrated antenna;
- iii) at no less than 1.5 m above ground level, at higher speed.

It should be noted that body-absorption/reflection losses could also be of importance in Class H-D under certain circumstances, for example when the terminal is in a pocket and file downloading is under way. However, this document does not consider this situation.

It is to be expected that there will be significant variation of reception conditions for handheld mobile reception, depending on the environment of the receiver. There might also be considerable variation of entry loss caused by the varying construction of cars and vehicles.

In both cases, it is assumed that the handheld mobile receiver and/or large objects near the receiver may move during the reception. It is also understood that extreme cases, such as reception in completely shielded vehicles, be disregarded.

Again, the difference between mobile reception and handheld mobile reception, Class H-C, lies in the different antenna gains which are assumed for the two reception modes.

A1.2 Coverage definitions

It is necessary to have definitions for the coverage of a terrestrial television transmitting station or a group of such stations. Digital television service coverage is characterized by a very rapid transition from near perfect reception to no reception at all and it thus becomes critical to be able to define which areas are going to be covered and which are not. However, because of the very rapid transition described above, there is a cost penalty if the coverage target within a small area (say, 100 m × 100 m) is set too high. This occurs because it is necessary either to increase the transmitter powers or to provide a larger number of transmitters in order to guarantee coverage to the last few percent of the worst-served small areas.

For this reason, the coverage definition of “good” has been selected as the case where 95% of the locations within a small area are covered. Similarly, “acceptable” has been defined to be the case where 70% of the locations within a small area are covered.

The definitions do not aim to describe the area where coverage is achieved under worst-case conditions. They provide a description of the area where “good” or “acceptable” coverage should be achieved under representative practical conditions. They may be regarded as describing the “quality” of the coverage achieved.

In defining the coverage area for each reception condition, a three-level approach is taken:

Receiving location

The smallest unit is a receiving location with dimensions of about 0.5 m × 0.5 m. In the case of portable antenna reception, it is assumed that optimal receiving conditions will be found by moving the antenna or by moving the handheld terminal up to 0.5 m in any direction.

Such a location is regarded as covered if the required carrier-to-noise and carrier-to-interference values are achieved for 99% of the time.

Small area coverage

The second level is a “small area” (typically 100 m × 100 m). In this small area the percentage of covered location is indicated.

The coverage of a small area is classified as:

- “Good”, if at least 95% of receiving locations within the area are covered for portable reception and 99% of receiving locations within it are covered for mobile reception.

- “Acceptable”, if at least 70% of receiving locations within the area are covered for portable reception and 90% of receiving locations within it are covered for mobile reception.

Coverage area

The third level is the coverage area.

The coverage area of a transmitter, or a group of transmitters, is made up of the sum of the individual small areas in which a given class of coverage is achieved.

A1.3 Calculation of signal levels

To calculate the minimum median power flux-density or equivalent field strength needed to ensure that the minimum values of signal level can be achieved at the required percentage of locations, the following formulas are used:

$$\phi_{min} = P_{s\ min} - A_a + L_f$$

$$E_{min} = \phi_{min} + 120 + 10 \log_{10} (120 \pi) = \phi_{min} + 145.8$$

$$\phi_{med} = \phi_{min} + P_{mmn} + C_1 \quad (\text{for fixed reception})$$

$$\phi_{med} = \phi_{min} + P_{mmn} + C_1 + L_h \quad (\text{for portable outdoor reception, Class A, mobile reception and, handheld portable outdoor reception, Class H-A, and handheld mobile vehicular reception, Class H-C})$$

$$\phi_{med} = \phi_{min} + P_{mmn} + C_1 + L_h + L_b \quad (\text{for portable indoor reception, Class B, and handheld portable indoor reception, Class H-B})$$

$$\phi_{med} = \phi_{min} + P_{mmn} + C_1 + L_h + L_v \quad (\text{for handheld mobile reception, Class H-D})$$

$$E_{med} = \phi_{med} + 120 + 10 \log_{10} (120 \pi) = \phi_{med} + 145.8$$

where:

C/N : RF signal-to-noise ratio required by the system (dB)

ϕ_{min} : Minimum power flux-density at receiving place (dBW/m²)

E_{min} : Equivalent minimum field strength at receiving place (dBμV/m)

L_f : Feeder loss (dB)

L_h : Height loss (10 m a.g.l. to 1.5 m a.g.l.) (dB)

L_b : Building penetration loss (dB)

L_v : Vehicle entry loss (dB)

P_{mmn} : Allowance for man-made noise (dB)

C_1 : Location correction factor (dB)

ϕ_{med} : Minimum median power flux-density, planning value (dBW/m²)

E_{med} : Minimum median equivalent field strength, planning value (dBμV/m)

A_a : Effective antenna aperture (dBm²) ($A_a = G_{iso} + 10 \log_{10}(\lambda^2/4\pi)$). G_{iso} is the antenna gain relative to an isotropic antenna

$P_{s\ min}$: Minimum receiver input power (dBW)

For calculating the location correction factor C_1 a log-normal distribution of the received signal is assumed.

$$C_1 = \mu * \sigma$$

where:

- μ : distribution factor, being 0.52 for 70%, 1.28 for 90%, 1.64 for 95% and 2.33 for 99%;
- σ : standard deviation taken as 5.5 dB for outdoor reception. See § A1.3.7 for σ values appropriate for indoor reception.

While the matters dealt with in this section are generally applicable, additional special considerations are needed in the case of SFNs where there is more than one wanted signal contribution.

A1.3.1 Antenna gain

The antenna gains used in the derivation of the minimum median wanted signal levels in § 3 are given in Table A1.1.

For portable and mobile reception, an omnidirectional antenna is applied.

Within any frequency band, the variation of antenna gain with frequency may be taken into account by the addition of a correction term:

$$Corr = 10 \log_{10}(F_A/F_R)$$

where:

- F_A : actual frequency being considered;
- F_R : relevant reference frequency quoted in § 3.

For further detailed information concerning the antenna gain values of handheld receivers, see § 1.3.3.2 of [Tech3317].

TABLE A1.1

Antenna gain in dBd for the different bands and for the different reception modes

	Gain (dBd)		Reception Mode
	Band III	Bands IV/ V	
Rooftop antenna	7	11	Fixed rooftop
Adapted antenna	-2.2	0	Portable Class A and B Mobile Handheld mobile vehicular Class H-C
External antenna*	-13	-5.5	Handheld portable outdoor Class H-A Handheld portable indoor Class H-B Handheld mobile reception H-D
Integrated antenna	-17	-9.5	Handheld portable outdoor Class H-A Handheld portable indoor Class H-B Handheld mobile reception H-D

* Telescopic or wired headsets.

A1.3.2 Feeder loss

The feeder losses used in the derivation of the minimum median wanted signal levels in § 3 are given in Table A1.2:

TABLE A1.2

Feeder loss in dB for the different bands

	Feeder loss (dB)		Reception Mode
	Band III	Bands IV/V	
Rooftop antenna	2	4	Fixed rooftop

Portable, mobile and handheld receivers can be assumed to have a low feeder loss in all bands. For planning purposes, no feeder losses are to be considered for portable, mobile and handheld reception.

A1.3.3 Man-made noise (MMN)

IRT measurements of man-made noise in Band III [BCP078] have shown much higher values than those assessed in the RRC-06 Report [RRC06] (8 dB instead of 2 dB in urban areas), affecting mobile reception using an adapted antenna (mobile reception and handheld mobile vehicular Class H-C). On the other hand the effect of man-made noise in the receiving environment is affected by the negative antenna gains. The full man-made noise values are only valid for antennas with a gain greater than 0 dBi (2.2 dBd). For antennas with a gain less than 0 dBi it is important to distinguish between the pure antenna gain and the efficiency of the antenna. The efficiency of the antenna reduces all received signals equally, also the man-made noise. Due to this, the relevant value for calculation purposes is reduced. In [BCP078] the treatment of man-made noise for negative isotropic antenna gains is further described.

The allowance for man-made noise for Bands IV and V is usually taken to be negligible. However, according to measurements [TR 102 377], an allowance of 1 dB is specified for Bands IV and V in urban areas for adapted antennas.

For planning purposes, the figures in Tables A1.3 and A1.4 are used.

In Recommendation ITU-R P.372-10, the difference between the man-made noise values for residential and rural areas is 2-3 dB. It seems reasonable to apply this difference also to the new man-made noise values here. Therefore the rural MMN value for adapted antennas in Band III is assumed to be 5 dB, in Bands IV/V 0 dB. The corresponding relevant values for external and integrated antennas are 0 dB in all bands.

It may be noted that there are also lower MMN values quoted for rural areas in accordance with [NTIA02-390] and [CPRT008].

TABLE A1.3

Allowance for man-made noise used in the calculation for urban areas

Urban	Band III	Bands IV/V	Reception Mode
Allowance for man-made noise			
Relevant value for integrated antenna	0	0	Handheld portable outdoor Class H-A Handheld portable indoor Class H-B Handheld mobile reception H-D
Relevant value for external antenna*	1	0	Handheld portable outdoor Class H-A Handheld portable indoor Class H-B Handheld mobile reception H-D
Relevant value for rooftop antenna	2 dB	0 dB	Fixed rooftop
Relevant value for adapted antenna	8 dB	1 dB	Portable Class A and B, Mobile Handheld mobile vehicular Class H-C

* Telescopic or wired handsets.

TABLE A1.4

Allowance for man-made noise used in the calculation for rural areas

Rural	Band III	Bands IV/V	Reception Mode
Allowance for man-made noise			
Relevant value for integrated antenna	0	0	Handheld portable outdoor Class H-A Handheld portable indoor Class H-B Handheld mobile reception H-D
Relevant value for external antenna*	0	0	Handheld portable outdoor Class H-A Handheld portable indoor Class H-B Handheld mobile reception H-D
Relevant value for rooftop antenna	2 dB	0 dB	Fixed rooftop
Relevant value for adapted antenna	5 dB	0 dB	Portable Class A and B Mobile Handheld mobile vehicular Class H-C

A1.3.4 Height loss

For portable (Classes A, B, H-A and H-B) and mobile reception (Classes H-C and H-D), the antenna height of 10 m above ground level, generally used for planning purposes, is not representative and a correction factor needs to be introduced based on a receiving antenna near ground floor level. For this reason a receiving antenna height of 1.5 m above ground level (outdoor) or above floor level (indoor) has been assumed.

The propagation prediction method of Recommendation ITU-R P.1546 uses a receiving height that corresponds to the height of the surrounding clutter (buildings etc.). To correct the predicted values for a receiving height of 1.5 m above ground level a factor called “height loss” has been introduced.

However, the height loss can also be specified for different types of receiving environments. CEPT ECC Report 49 [ECC049] provides the height loss values for some type of environments.

For planning purposes the values in Table A1.5 could be used for the different bands and environment classes.

TABLE A1.5

Height loss for the different bands and environment classes

	Receiving antenna height loss (dB)	
	Band III	Bands IV/V
Urban	19	23.5
Suburban	12	17
Rural	12	16.5

The height loss values are based on Recommendation ITU-R P.1546.

The height loss may also depend on the distance between the transmitter and the receiver, which makes it variable with the size of the coverage area. Therefore, in this document the Figures of minimum median equivalent field strength for portable (Classes A, B, H-A and H-B) and mobile reception (Classes H-C and H-D) are calculated at 1.5 m a.g.l. The values of height loss given in this section could be used to derive the minimum median equivalent field strength corresponding to the height of the surrounding clutter (buildings etc.). Further investigations about the height loss are, however, needed.

For fixed reception the figures of minimum median equivalent field strength are calculated at 10 m a.g.l.

A1.3.5 Building penetration loss

Portable reception will take place at outdoor and indoor locations. The field strength at indoor locations will be significantly attenuated by an amount depending on the materials of, and the construction of the building. A large spread of building penetration losses and entry losses for moving objects is to be expected.

For planning purposes, the present document assumes the values shown in Table A1.6 for Class B (portable indoor) and Class H-B (handheld portable indoor).

TABLE A1.6

Building penetration loss

Band	Class B/Portable indoor reception Class H-B/Handheld portable indoor reception	
	Median value (dB)	Standard deviation (dB)
Band III	9	3
Bands IV/V	11	6

For Band III, the values are taken from the GE06 Final Acts [RRC06].

For Bands IV and V, the values are taken from the ETSI DVB-H implementation guidelines [TR 102 377] where further information on building penetration loss can be found.

A1.3.6 Vehicle (car) entry loss

For Class H-D (mobile inside vehicle), the values shown in Table A1.7 are used in the calculations:

TABLE A1.7
Vehicle (car) entry loss

Band	Class H-D	
	Median value (dB)	Standard deviation (dB)
Band III	8	2
Bands IV/V	8	2

These values come from a study presented in [KHM1998] which shows in-car penetration losses of 8 dB with an associated standard deviation of 2-3 dB, based on measurements at 800 MHz.

Furthermore, it is expected that the value of 8 dB will not be sufficient for estimating penetration loss into trains.

Due to the lack of investigations concerning the car entry loss and its variation with the frequency, the same value is taken for all Bands III and IV/V. Further studies are needed on this subject.

A1.3.7 Location percentage

A1.3.7.1 Signal level variations

Field strength variations can be divided into macro-scale and micro-scale variations. The macro-scale variations relate to areas with linear dimensions of 10 m to 100 m or more and are mainly caused by shadowing, reflection and scattering. The micro-scale variations relate to areas with dimensions in the order of a wavelength and are mainly caused by multi-path reflections from nearby objects. The effect of micro-scale fading is normally taken into account by an appropriate C/N value for the transmission channel under consideration. Moreover, as it may be assumed that for portable reception the position of the antenna can be optimized within the order of a wavelength, micro-scale variations will not be too significant for planning purposes.

Macro-scale variations of the field strength are very important for coverage assessment. In general, a high target percentage for coverage would be required to compensate for the rapid failure rate of digital TV signals. Therefore an extra correction is required to the value derived from a field strength prediction that applies to 50% of locations.

A1.3.7.2 Location percentage requirements at outdoor locations (Portable Classes A and H-A)

Recommendation ITU-R P.1546 gives a standard deviation for wideband signals of 5.5 dB. This value is used here for determining the location correction factor for outdoor locations for all Bands III and IV/V.

TABLE A1.8

**Macro-scale variation for portable outdoor reception:
Coverage targets and location correction factors**

Classes A and H-A, all bands	
Coverage target	Location correction factor (dB)
>70%	3
>95%	9

A1.3.7.3 Location percentage requirements at indoor locations (Classes B and H-B)

The location correction factor at indoor locations is the combined result of the outdoor variation and the variation factor due to building attenuation. These distributions are expected to be uncorrelated. The standard deviation of the indoor field strength distribution can therefore be calculated by taking the root of the sum of the squares of the individual standard deviations. As a consequence, the location variation of the field strength is increased for indoor reception.

In Band III, where the macro-scale standard deviations are 5.5 dB and 3 dB (§ A1.3.5), respectively, the combined value is 6.3 dB.

In Bands IV/V, where the macro-scale standard deviations are 5.5 dB and 6 dB (§ A1.3.5), respectively, the combined value is 8.1 dB.

TABLE A1.9

**Macro-scale variation for portable indoor reception:
Coverage targets and location correction factors**

Coverage target	Classes B and H-B	
	Location correction factor (dB)	
	Band III	Bands IV/V
>70%	3	4
>95%	10	13

The resultant location correction factors at indoor locations for the different bands are given in Table A1.9.

A1.3.7.4 Location percentage requirements for mobile and handheld mobile vehicular reception, Class H-C

The value of standard deviation given in § A1.3.7.2 is used here for determining the location variation at outdoor locations for mobile and handheld mobile vehicular reception. To cope with a mobile environment, larger values of location correction factors than for portable reception are used.

These location correction factors are given in Table A1.10.

TABLE A1.10

Macro-scale variation for mobile reception: Coverage targets and location correction factors

Mobile reception, all bands	
Coverage target	Location correction factor (dB)
>90%	7
>99%	13

A1.3.7.5 Location percentage requirements for handheld reception in a moving vehicle (Class H-D)

The location correction factor for handheld reception in a moving vehicle is the combined result of the outdoor variation and the variation factor due to vehicle penetration loss. These distributions are expected to be uncorrelated. The standard deviation of the field strength distribution for handheld reception in a moving vehicle can therefore be calculated by taking the root of the sum of the squares of the individual standard deviations.

In all bands, the macro-scale standard deviations are 5.5 dB and 2 dB (§ A1.3.6), respectively; the combined value is 5.9 dB.

The resultant location correction factors for handheld reception in a moving vehicle (Class H-D) are given in Table A1.11.

TABLE A1.11

Macro-scale variation for handheld reception in a moving vehicle (Class H-D): Coverage targets and location correction factors

Class H-D, all bands	
Coverage target	Location correction factor (dB)
>90%	7.6
>99%	13.7

A1.3.8 Frequency interpolation in the UHF band (Bands IV and V)

The minimum median field strength F_{S1} for a frequency f_1 using the value of the field strength F_S for the frequency f given in the examples, for Bands IV/V, may be calculated from [RRC06]:

$$\text{for fixed reception:} \quad F_{S1} = F_S + 20 \log_{10}(f_1/f), \text{ and}$$

$$\text{for portable and mobile reception:} \quad F_{S1} = F_S + 30 \log_{10}(f_1/f)$$

The difference between the two cases is due to the fact that the height loss scales with an additional factor of $10 \log_{10}(f_1/f)$.

Annex 2

Estimation of the net data capacity of a DVB-T2 multiplex

The exact data capacity of a DVB-T2 configuration depends on a large number of parameters. Possible combinations of FFT and guard interval fraction (GIF) for different bandwidths are given in Tables 2.5, 2.6 and 2.7 in § 2.3. In addition, only selected scattered pilot patterns are allowed for a specific combination of FFT and GIF. These are given in Table 2.19 in § 2.7 for the SISO mode and in Table 4.2 in § 4.3 for the MISO mode. For convenience, the latter two tables are repeated below in Tables A2.1 and A2.2, and a summary of Tables 2.5 to 2.7 is given in Table A2.3.

This Annex gives an overview of the net data capacity of a DVB-T2 multiplex. The information is taken from [AFM2010] and is based on the data rates given in [A133] for the 32k mode taking into account scattered pilot pattern, bandwidth-extension, guard interval fraction and symbol length.

The error associated with this estimation should be less than 0.5% for an 8 MHz channel and less than 3.5% for a 1.7 MHz channel.

In general, the data rate is independent of the FFT mode as long as other parameters such as GIF or code rate are kept unchanged. However, the bandwidth extension depends on the FFT mode. The net data capacities for different DVB-T2 configurations in an 8 MHz and a 1.7 MHz channel are given in Tables A2.4 to A2.7. The net data capacity in a 7 MHz channel may be calculated from the 8 MHz channel case by taking a fraction of 7/8.

All fields in Tables A2.4 through A2.7 are filled, even if a particular combination of FFT, GIF and scattered pilot pattern is not possible. Then this data capacity is only hypothetical and not available in practice. It is up to the reader to verify by means of Tables A2.1 to A2.3 whether a particular combination is applicable in practice.

Combinations not listed in Tables A2.4 through A2.7 are not available.

TABLE A2.1

Scattered pilot pattern to be used for each allowed combination of FFT size and guard interval in SISO mode (from [EN 302 755])

FFT size	Guard interval						
	1/128	1/32	1/16	19/256	1/8	19/128	1/4
32k	PP7	PP4 PP6	PP2 PP8 PP4	PP2 PP8 PP4	PP2 PP8	PP2 PP8	n/a
16k	PP7	PP7 PP4 PP6	PP2 PP8 PP4 PP5	PP2 PP8 PP4 PP5	PP2 PP3 PP8	PP2 PP3 PP8	PP1 PP8
8k	PP7	PP7 PP4	PP8 PP4 PP5	PP8 PP4 PP5	PP2 PP3 PP8	PP2 PP3 PP8	PP1 PP8
4k, 2k	n/a	PP7 PP4	PP4 PP5	n/a	PP2 PP3	n/a	PP1
1k	n/a	n/a	PP4 PP5	n/a	PP2 PP3	n/a	PP1

TABLE A2.2

Scattered pilot pattern to be used for each allowed combination of FFT size and guard interval in MISO mode (from [EN 302 755])

FFT size	Guard interval						
	1/128	1/32	1/16	19/256	1/8	19/128	1/4
32k	PP8 PP4 PP6	PP8 PP4	PP2 PP8	PP2 PP8	<i>n/a</i>	<i>n/a</i>	<i>n/a</i>
16k	PP8 PP4 PP5	PP8 PP4 PP5	PP3 PP8	PP3 PP8	PP1 PP8	PP1 PP8	<i>n/a</i>
8k	PP8 PP4 PP5	PP8 PP4 PP5	PP3 PP8	PP3 PP8	PP1 PP8	PP1 PP8	<i>n/a</i>
4k, 2k	<i>n/a</i>	PP4 PP5	PP3	<i>n/a</i>	PP1	<i>n/a</i>	<i>n/a</i>
1k	<i>n/a</i>	<i>n/a</i>	PP3	<i>n/a</i>	PP1	<i>n/a</i>	<i>n/a</i>

TABLE A2.3

Allowed combinations of FFT and GIF

FFT	GIF						
	1/128	1/32	1/16	19/256	1/8	19/128	1/4
32k	Yes	Yes	Yes	Yes	Yes	Yes	No
16k	Yes	Yes	Yes	Yes	Yes	Yes	Yes
8k	Yes	Yes	Yes	Yes	Yes	Yes	Yes
4k	No	Yes	Yes	No	Yes	No	No
2k	No	Yes	Yes	No	Yes	No	No
1k	No	No	Yes	No	Yes	No	No

TABLE A2.4

Capacity in a 8 MHz channel, normal carrier mode, FFT modes: 1k to 32k

Modulation	Code rate	Scattered Pilot Pattern 1 & 2							Scattered Pilot Pattern 3 & 4						
		GIF							GIF						
		1/128 (Mbit/s)	1/32 (Mbit/s)	1/16 (Mbit/s)	19/256 (Mbit/s)	1/8 (Mbit/s)	19/128 (Mbit/s)	1/4 (Mbit/s)	1/128 (Mbit/s)	1/32 (Mbit/s)	1/16 (Mbit/s)	19/256 (Mbit/s)	1/8 (Mbit/s)	19/128 (Mbit/s)	1/4 (Mbit/s)
QPSK	1/2	6.8	6.6	6.5	6.4	6.1	6.0	5.5	7.1	6.9	6.7	6.7	6.4	6.2	5.7
	3/5	8.2	8.0	7.8	7.7	7.3	7.2	6.6	8.5	8.3	8.1	8.0	7.7	7.5	6.9
	2/3	9.1	8.9	8.6	8.5	8.2	8.0	7.3	9.5	9.3	9.0	8.9	8.5	8.3	7.7
	3/4	10.2	10.0	9.7	9.6	9.2	9.0	8.3	10.7	10.4	10.1	10.0	9.6	9.4	8.6
	4/5	10.9	10.7	10.4	10.2	9.8	9.6	8.8	11.4	11.1	10.8	10.7	10.2	10.0	9.2
	5/6	11.4	11.1	10.8	10.7	10.2	10.0	9.2	11.9	11.6	11.3	11.2	10.7	10.4	9.6
16-QAM	1/2	13.6	13.3	12.9	12.8	12.2	12.0	11.0	14.3	13.9	13.5	13.4	12.8	12.5	11.5
	3/5	16.4	16.0	15.6	15.4	14.7	14.4	13.2	17.1	16.7	16.3	16.1	15.4	15.1	13.8
	2/3	18.2	17.8	17.3	17.1	16.4	16.0	14.7	19.1	18.6	18.1	17.9	17.1	16.7	15.4
	3/4	20.5	20.1	19.5	19.3	18.4	18.0	16.6	21.4	21.0	20.4	20.1	19.2	18.8	17.3
	4/5	21.9	21.4	20.8	20.6	19.6	19.2	17.7	22.9	22.4	21.7	21.5	20.5	20.1	18.5
	5/6	22.8	22.3	21.7	21.4	20.5	20.1	18.4	23.9	23.3	22.6	22.4	21.4	21.0	19.3
64-QAM	1/2	20.4	20.0	19.4	19.2	18.3	18.0	16.5	21.4	20.9	20.3	20.0	19.1	18.8	17.2
	3/5	24.6	24.0	23.3	23.1	22.0	21.6	19.8	25.7	25.1	24.4	24.1	23.0	22.5	20.7
	2/3	27.3	26.7	25.9	25.7	24.5	24.0	22.1	28.6	27.9	27.1	26.8	25.6	25.1	23.1
	3/4	30.7	30.0	29.2	28.9	27.6	27.0	24.8	32.1	31.4	30.5	30.2	28.8	28.2	25.9
	4/5	32.8	32.1	31.1	30.8	29.4	28.8	26.5	34.3	33.5	32.5	32.2	30.7	30.1	27.7
	5/6	34.2	33.4	32.5	32.1	30.7	30.0	27.6	35.7	34.9	33.9	33.5	32.0	31.4	28.9
256-QAM	1/2	27.3	26.7	25.9	25.6	24.5	24.0	22.1	28.5	27.9	27.1	26.8	25.6	25.1	23.0
	3/5	32.8	32.1	31.1	30.8	29.4	28.8	26.5	34.3	33.5	32.5	32.2	30.7	30.1	27.7
	2/3	36.5	35.7	34.6	34.3	32.7	32.1	29.5	38.1	37.3	36.2	35.8	34.2	33.5	30.8
	3/4	41.1	40.1	39.0	38.6	36.8	36.1	33.2	42.9	41.9	40.7	40.3	38.5	37.7	34.7
	4/5	43.8	42.8	41.6	41.1	39.3	38.5	35.4	45.8	44.8	43.5	43.0	41.1	40.2	37.0
	5/6	45.7	44.7	43.4	42.9	41.0	40.1	36.9	47.7	46.7	45.3	44.8	42.8	41.9	38.6

TABLE A2.4 (end)

Modulation	Code rate	Scattered Pilot Pattern 5 & 6							Scattered Pilot Pattern 7 & 8						
		GIF							GIF						
		1/128 (Mbit/s)	1/32 (Mbit/s)	1/16 (Mbit/s)	19/256 (Mbit/s)	1/8 (Mbit/s)	19/128 (Mbit/s)	1/4 (Mbit/s)	1/128 (Mbit/s)	1/32 (Mbit/s)	1/16 (Mbit/s)	19/256 (Mbit/s)	1/8 (Mbit/s)	19/128 (Mbit/s)	1/4 (Mbit/s)
QPSK	1/2	7.3	7.1	6.9	6.8	6.5	6.4	5.9	7.3	7.2	7.0	6.9	6.6	6.4	5.9
	3/5	8.7	8.5	8.3	8.2	7.8	7.7	7.0	8.8	8.6	8.4	8.3	7.9	7.7	7.1
	2/3	9.7	9.5	9.2	9.1	8.7	8.5	7.8	9.8	9.6	9.3	9.2	8.8	8.6	7.9
	3/4	10.9	10.7	10.4	10.2	9.8	9.6	8.8	11.0	10.8	10.5	10.4	9.9	9.7	8.9
	4/5	11.6	11.4	11.1	10.9	10.4	10.2	9.4	11.8	11.5	11.2	11.0	10.6	10.3	9.5
	5/6	12.1	11.9	11.5	11.4	10.9	10.7	9.8	12.3	12.0	11.6	11.5	11.0	10.8	9.9
16-QAM	1/2	14.6	14.2	13.8	13.7	13.1	12.8	11.8	14.7	14.4	14.0	13.8	13.2	12.9	11.9
	3/5	17.5	17.1	16.6	16.4	15.7	15.4	14.1	17.7	17.3	16.8	16.6	15.9	15.5	14.3
	2/3	19.5	19.0	18.5	18.3	17.5	17.1	15.7	19.7	19.2	18.7	18.5	17.6	17.3	15.9
	3/4	21.9	21.4	20.8	20.6	19.6	19.2	17.7	22.1	21.6	21.0	20.8	19.9	19.5	17.9
	4/5	23.4	22.9	22.2	21.9	21.0	20.5	18.9	23.6	23.1	22.4	22.2	21.2	20.8	19.1
	5/6	24.4	23.8	23.1	22.9	21.9	21.4	19.7	24.6	24.1	23.4	23.1	22.1	21.6	19.9
64-QAM	1/2	21.8	21.3	20.7	20.5	19.6	19.2	17.6	22.0	21.5	20.9	20.7	19.8	19.4	17.8
	3/5	26.2	25.6	24.9	24.6	23.5	23.0	21.2	26.5	25.9	25.1	24.9	23.8	23.3	21.4
	2/3	29.2	28.5	27.7	27.4	26.2	25.6	23.6	29.5	28.8	28.0	27.7	26.4	25.9	23.8
	3/4	32.8	32.1	31.1	30.8	29.4	28.8	26.5	33.2	32.4	31.5	31.1	29.7	29.1	26.8
	4/5	35.0	34.2	33.2	32.9	31.4	30.8	28.3	35.4	34.6	33.6	33.2	31.7	31.1	28.6
	5/6	36.5	35.7	34.6	34.3	32.7	32.1	29.5	36.9	36.1	35.0	34.6	33.1	32.4	29.8
256-QAM	1/2	29.1	28.5	27.7	27.4	26.1	25.6	23.5	29.5	28.8	27.9	27.6	26.4	25.9	23.8
	3/5	35.0	34.2	33.2	32.9	31.4	30.8	28.3	35.4	34.6	33.6	33.2	31.7	31.1	28.6
	2/3	39.0	38.1	37.0	36.6	34.9	34.2	31.5	39.4	38.5	37.4	37.0	35.3	34.6	31.8
	3/4	43.8	42.9	41.6	41.2	39.3	38.5	35.4	44.3	43.3	42.0	41.6	39.7	38.9	35.8
	4/5	46.8	45.7	44.4	43.9	41.9	41.1	37.8	47.3	46.2	44.9	44.4	42.4	41.5	38.2
	5/6	48.8	47.7	46.3	45.8	43.7	42.8	39.4	49.3	48.2	46.8	46.3	44.2	43.3	39.8

TABLE A2.5

Capacity in a 8 MHz channel, extended carrier mode, FFT mode: 8k

Modulation	Code rate	Scattered Pilot Pattern 1 & 2							Scattered Pilot Pattern 3 & 4						
		GIF							GIF						
		1/128 (Mbit/s)	1/32 (Mbit/s)	1/16 (Mbit/s)	19/256 (Mbit/s)	1/8 (Mbit/s)	19/128 (Mbit/s)	1/4 (Mbit/s)	1/128 (Mbit/s)	1/32 (Mbit/s)	1/16 (Mbit/s)	19/256 (Mbit/s)	1/8 (Mbit/s)	19/128 (Mbit/s)	1/4 (Mbit/s)
QPSK	1/2	6.9	6.7	6.5	6.5	6.2	6.1	5.6	7.2	7.0	6.8	6.8	6.5	6.3	5.8
	3/5	8.3	8.1	7.9	7.8	7.4	7.3	6.7	8.7	8.5	8.2	8.1	7.8	7.6	7.0
	2/3	9.2	9.0	8.8	8.7	8.3	8.1	7.4	9.6	9.4	9.1	9.0	8.6	8.5	7.8
	3/4	10.4	10.1	9.8	9.7	9.3	9.1	8.4	10.8	10.6	10.3	10.2	9.7	9.5	8.8
	4/5	11.1	10.8	10.5	10.4	9.9	9.7	8.9	11.6	11.3	11.0	10.9	10.4	10.2	9.3
	5/6	11.5	11.3	11.0	10.8	10.3	10.1	9.3	12.1	11.8	11.4	11.3	10.8	10.6	9.7
16-QAM	1/2	13.8	13.5	13.1	13.0	12.4	12.2	11.2	14.5	14.1	13.7	13.6	13.0	12.7	11.7
	3/5	16.6	16.3	15.8	15.6	14.9	14.6	13.4	17.4	17.0	16.5	16.3	15.6	15.3	14.0
	2/3	18.5	18.1	17.6	17.4	16.6	16.3	15.0	19.3	18.9	18.4	18.2	17.3	17.0	15.6
	3/4	20.8	20.4	19.8	19.5	18.7	18.3	16.8	21.8	21.3	20.6	20.4	19.5	19.1	17.6
	4/5	22.2	21.7	21.1	20.9	19.9	19.5	17.9	23.2	22.7	22.0	21.8	20.8	20.4	18.8
	5/6	23.2	22.6	22.0	21.7	20.8	20.3	18.7	24.2	23.7	23.0	22.7	21.7	21.3	19.6
64-QAM	1/2	20.7	20.3	19.7	19.5	18.6	18.2	16.7	21.7	21.2	20.6	20.3	19.4	19.0	17.5
	3/5	24.9	24.4	23.6	23.4	22.3	21.9	20.1	26.0	25.4	24.7	24.4	23.3	22.9	21.0
	2/3	27.7	27.1	26.3	26.0	24.9	24.4	22.4	29.0	28.3	27.5	27.2	26.0	25.4	23.4
	3/4	31.2	30.5	29.6	29.3	28.0	27.4	25.2	32.6	31.8	30.9	30.6	29.2	28.6	26.3
	4/5	33.3	32.5	31.6	31.2	29.8	29.2	26.9	34.8	34.0	33.0	32.6	31.2	30.5	28.1
	5/6	34.7	33.9	32.9	32.6	31.1	30.5	28.0	36.2	35.4	34.4	34.0	32.5	31.8	29.3
256-QAM	1/2	27.7	27.1	26.3	26.0	24.8	24.3	22.4	28.9	28.3	27.5	27.2	25.9	25.4	23.4
	3/5	33.3	32.5	31.6	31.2	29.8	29.2	26.9	34.8	34.0	33.0	32.6	31.2	30.6	28.1
	2/3	37.0	36.2	35.1	34.8	33.2	32.5	29.9	38.7	37.8	36.7	36.3	34.7	34.0	31.3
	3/4	41.7	40.7	39.5	39.1	37.4	36.6	33.7	43.5	42.6	41.3	40.9	39.0	38.2	35.2
	4/5	44.5	43.5	42.2	41.7	39.9	39.1	35.9	46.5	45.4	44.1	43.6	41.7	40.8	37.5
	5/6	46.3	45.3	44.0	43.5	41.6	40.7	37.4	48.4	47.3	46.0	45.5	43.4	42.5	39.1

TABLE A2.5 (end)

Modulation	Code rate	Scattered Pilot Pattern 5 & 6							Scattered Pilot Pattern 7 & 8						
		GIF							GIF						
		1/128 (Mbit/s)	1/32 (Mbit/s)	1/16 (Mbit/s)	19/256 (Mbit/s)	1/8 (Mbit/s)	19/128 (Mbit/s)	1/4 (Mbit/s)	1/128 (Mbit/s)	1/32 (Mbit/s)	1/16 (Mbit/s)	19/256 (Mbit/s)	1/8 (Mbit/s)	19/128 (Mbit/s)	1/4 (Mbit/s)
QPSK	1/2	7.4	7.2	7.0	6.9	6.6	6.5	5.9	7.4	7.3	7.1	7.0	6.7	6.5	6.0
	3/5	8.8	8.6	8.4	8.3	7.9	7.8	7.1	8.9	8.7	8.5	8.4	8.0	7.9	7.2
	2/3	9.8	9.6	9.3	9.2	8.8	8.6	8.0	9.9	9.7	9.4	9.3	8.9	8.7	8.0
	3/4	11.1	10.8	10.5	10.4	9.9	9.7	8.9	11.2	10.9	10.6	10.5	10.0	9.8	9.0
	4/5	11.8	11.6	11.2	11.1	10.6	10.4	9.5	11.9	11.7	11.3	11.2	10.7	10.5	9.6
	5/6	12.3	12.0	11.7	11.6	11.0	10.8	10.0	12.4	12.2	11.8	11.7	11.2	10.9	10.1
16-QAM	1/2	14.8	14.4	14.0	13.9	13.2	13.0	11.9	14.9	14.6	14.2	14.0	13.4	13.1	12.1
	3/5	17.8	17.4	16.8	16.7	15.9	15.6	14.3	17.9	17.5	17.0	16.8	16.1	15.8	14.5
	2/3	19.8	19.3	18.7	18.5	17.7	17.4	16.0	20.0	19.5	18.9	18.7	17.9	17.5	16.1
	3/4	22.2	21.7	21.1	20.9	19.9	19.5	18.0	22.5	22.0	21.3	21.1	20.1	19.7	18.1
	4/5	23.7	23.2	22.5	22.3	21.3	20.8	19.2	24.0	23.4	22.7	22.5	21.5	21.1	19.4
	5/6	24.7	24.2	23.5	23.2	22.2	21.7	20.0	25.0	24.4	23.7	23.5	22.4	21.9	20.2
64-QAM	1/2	22.1	21.6	21.0	20.8	19.8	19.4	17.9	22.4	21.9	21.2	21.0	20.1	19.6	18.1
	3/5	26.6	26.0	25.2	25.0	23.8	23.4	21.5	26.9	26.3	25.5	25.2	24.1	23.6	21.7
	2/3	29.6	28.9	28.1	27.8	26.5	26.0	23.9	29.9	29.2	28.4	28.1	26.8	26.3	24.2
	3/4	33.3	32.5	31.6	31.2	29.8	29.2	26.9	33.6	32.9	31.9	31.6	30.2	29.5	27.2
	4/5	35.5	34.7	33.7	33.3	31.8	31.2	28.7	35.9	35.1	34.1	33.7	32.2	31.5	29.0
	5/6	37.0	36.2	35.1	34.8	33.2	32.5	29.9	37.4	36.6	35.5	35.1	33.5	32.9	30.2
256-QAM	1/2	29.6	28.9	28.1	27.8	26.5	26.0	23.9	29.9	29.2	28.3	28.0	26.8	26.2	24.1
	3/5	35.5	34.7	33.7	33.3	31.9	31.2	28.7	35.9	35.1	34.1	33.7	32.2	31.5	29.0
	2/3	39.5	38.6	37.5	37.1	35.4	34.7	31.9	39.9	39.0	37.9	37.5	35.8	35.1	32.3
	3/4	44.5	43.5	42.2	41.7	39.9	39.1	35.9	44.9	43.9	42.6	42.2	40.3	39.5	36.3
	4/5	47.5	46.4	45.0	44.5	42.5	41.7	38.3	48.0	46.9	45.5	45.0	43.0	42.1	38.7
	5/6	49.5	48.4	46.9	46.4	44.4	43.5	40.0	50.0	48.9	47.4	46.9	44.8	43.9	40.4

TABLE A2.6

Capacity in a 8 MHz channel, extended carrier mode, FFT modes: 16k and 32k

Modulation	Code rate	Scattered Pilot Pattern 1 & 2							Scattered Pilot Pattern 3 & 4						
		GIF							GIF						
		1/128 (Mbit/s)	1/32 (Mbit/s)	1/16 (Mbit/s)	19/256 (Mbit/s)	1/8 (Mbit/s)	19/128 (Mbit/s)	1/4 (Mbit/s)	1/128 (Mbit/s)	1/32 (Mbit/s)	1/16 (Mbit/s)	19/256 (Mbit/s)	1/8 (Mbit/s)	19/128 (Mbit/s)	1/4 (Mbit/s)
QPSK	1/2	6.9	6.8	6.6	6.5	6.2	6.1	5.6	7.3	7.1	6.9	6.8	6.5	6.4	5.9
	3/5	8.3	8.2	7.9	7.8	7.5	7.3	6.7	8.7	8.5	8.3	8.2	7.8	7.7	7.0
	2/3	9.3	9.1	8.8	8.7	8.3	8.2	7.5	9.7	9.5	9.2	9.1	8.7	8.5	7.8
	3/4	10.4	10.2	9.9	9.8	9.4	9.2	8.4	10.9	10.7	10.4	10.2	9.8	9.6	8.8
	4/5	11.1	10.9	10.6	10.5	10.0	9.8	9.0	11.6	11.4	11.1	10.9	10.4	10.2	9.4
	5/6	11.6	11.4	11.0	10.9	10.4	10.2	9.4	12.1	11.9	11.5	11.4	10.9	10.7	9.8
16-QAM	1/2	13.9	13.6	13.2	13.1	12.5	12.2	11.3	14.6	14.2	13.8	13.7	13.1	12.8	11.8
	3/5	16.8	16.4	15.9	15.7	15.0	14.7	13.5	17.5	17.1	16.6	16.4	15.7	15.4	14.1
	2/3	18.6	18.2	17.7	17.5	16.7	16.4	15.1	19.5	19.0	18.5	18.3	17.5	17.1	15.7
	3/4	21.0	20.5	19.9	19.7	18.8	18.4	16.9	21.9	21.4	20.8	20.6	19.6	19.2	17.7
	4/5	22.4	21.9	21.2	21.0	20.1	19.7	18.1	23.4	22.9	22.2	21.9	21.0	20.5	18.9
	5/6	23.3	22.8	22.1	21.9	20.9	20.5	18.8	24.4	23.8	23.1	22.9	21.9	21.4	19.7
64-QAM	1/2	20.9	20.4	19.8	19.6	18.7	18.3	16.9	21.8	21.3	20.7	20.5	19.6	19.2	17.6
	3/5	25.1	24.5	23.8	23.6	22.5	22.0	20.3	26.2	25.6	24.9	24.6	23.5	23.0	21.2
	2/3	27.9	27.3	26.5	26.2	25.0	24.5	22.6	29.2	28.5	27.7	27.4	26.2	25.6	23.6
	3/4	31.4	30.7	29.8	29.5	28.2	27.6	25.4	32.8	32.1	31.1	30.8	29.4	28.8	26.5
	4/5	33.5	32.8	31.8	31.5	30.0	29.4	27.1	35.0	34.2	33.2	32.9	31.4	30.8	28.3
	5/6	34.9	34.1	33.2	32.8	31.3	30.7	28.2	36.5	35.7	34.6	34.3	32.7	32.1	29.5
256-QAM	1/2	27.9	27.3	26.5	26.2	25.0	24.5	22.5	29.1	28.5	27.7	27.4	26.1	25.6	23.5
	3/5	33.5	32.8	31.8	31.5	30.1	29.4	27.1	35.0	34.2	33.2	32.9	31.4	30.8	28.3
	2/3	37.3	36.5	35.4	35.0	33.4	32.8	30.1	39.0	38.1	37.0	36.6	34.9	34.2	31.5
	3/4	42.0	41.0	39.8	39.4	37.6	36.9	33.9	43.8	42.9	41.6	41.2	39.3	38.5	35.4
	4/5	44.8	43.8	42.5	42.0	40.1	39.3	36.2	46.8	45.7	44.4	43.9	41.9	41.1	37.8
	5/6	46.7	45.6	44.3	43.8	41.9	41.0	37.7	48.8	47.7	46.3	45.8	43.7	42.8	39.4

TABLE A2.6 (end)

Modulation	Code rate	Scattered Pilot Pattern 5 & 6							Scattered Pilot Pattern 7 & 8						
		GIF							GIF						
		1/128 (Mbit/s)	1/32 (Mbit/s)	1/16 (Mbit/s)	19/256 (Mbit/s)	1/8 (Mbit/s)	19/128 (Mbit/s)	1/4 (Mbit/s)	1/128 (Mbit/s)	1/32 (Mbit/s)	1/16 (Mbit/s)	19/256 (Mbit/s)	1/8 (Mbit/s)	19/128 (Mbit/s)	1/4 (Mbit/s)
QPSK	1/2	7.4	7.2	7.0	7.0	6.6	6.5	6.0	7.5	7.3	7.1	7.0	6.7	6.6	6.1
	3/5	8.9	8.7	8.5	8.4	8.0	7.8	7.2	9.0	8.8	8.5	8.5	8.1	7.9	7.3
	2/3	9.9	9.7	9.4	9.3	8.9	8.7	8.0	10.0	9.8	9.5	9.4	9.0	8.8	8.1
	3/4	11.2	10.9	10.6	10.5	10.0	9.8	9.0	11.3	11.0	10.7	10.6	10.1	9.9	9.1
	4/5	11.9	11.6	11.3	11.2	10.7	10.5	9.6	12.0	11.8	11.4	11.3	10.8	10.6	9.7
	5/6	12.4	12.1	11.8	11.6	11.1	10.9	10.0	12.5	12.3	11.9	11.8	11.2	11.0	10.1
16-QAM	1/2	14.9	14.5	14.1	14.0	13.3	13.1	12.0	15.0	14.7	14.3	14.1	13.5	13.2	12.1
	3/5	17.9	17.5	17.0	16.8	16.0	15.7	14.4	18.1	17.7	17.1	17.0	16.2	15.9	14.6
	2/3	19.9	19.4	18.9	18.7	17.8	17.5	16.1	20.1	19.7	19.1	18.9	18.0	17.7	16.2
	3/4	22.4	21.9	21.2	21.0	20.1	19.7	18.1	22.6	22.1	21.5	21.2	20.3	19.9	18.3
	4/5	23.9	23.3	22.7	22.4	21.4	21.0	19.3	24.1	23.6	22.9	22.7	21.6	21.2	19.5
	5/6	24.9	24.3	23.6	23.4	22.3	21.9	20.1	25.2	24.6	23.9	23.6	22.6	22.1	20.3
64-QAM	1/2	22.3	21.8	21.1	20.9	20.0	19.6	18.0	22.5	22.0	21.4	21.1	20.2	19.8	18.2
	3/5	26.8	26.2	25.4	25.1	24.0	23.5	21.6	27.1	26.5	25.7	25.4	24.3	23.8	21.9
	2/3	29.8	29.1	28.3	28.0	26.7	26.2	24.1	30.1	29.4	28.6	28.3	27.0	26.5	24.3
	3/4	33.5	32.8	31.8	31.5	30.1	29.4	27.1	33.9	33.1	32.1	31.8	30.4	29.8	27.4
	4/5	35.8	35.0	33.9	33.6	32.1	31.4	28.9	36.1	35.3	34.3	33.9	32.4	31.8	29.2
	5/6	37.3	36.4	35.4	35.0	33.4	32.8	30.1	37.7	36.8	35.8	35.4	33.8	33.1	30.4
256-QAM	1/2	29.8	29.1	28.3	27.9	26.7	26.2	24.1	30.1	29.4	28.6	28.2	27.0	26.4	24.3
	3/5	35.8	35.0	34.0	33.6	32.1	31.4	28.9	36.2	35.3	34.3	33.9	32.4	31.8	29.2
	2/3	39.8	38.9	37.8	37.4	35.7	35.0	32.2	40.2	39.3	38.2	37.8	36.1	35.3	32.5
	3/4	44.8	43.8	42.5	42.0	40.2	39.3	36.2	45.3	44.2	42.9	42.5	40.6	39.8	36.6
	4/5	47.8	46.7	45.3	44.9	42.9	42.0	38.6	48.3	47.2	45.8	45.3	43.3	42.4	39.0
	5/6	49.8	48.7	47.3	46.8	44.7	43.8	40.2	50.3	49.2	47.8	47.3	45.1	44.2	40.7

TABLE A2.7

Capacity in a 1.7 MHz channel, normal carrier mode, FFT modes: 1k to 8k

Modulation	Code rate	Scattered Pilot Pattern 1 & 2							Scattered Pilot Pattern 3 & 4						
		GIF							GIF						
		1/128 (Mbit/s)	1/32 (Mbit/s)	1/16 (Mbit/s)	19/256 (Mbit/s)	1/8 (Mbit/s)	19/128 (Mbit/s)	1/4 (Mbit/s)	1/128 (Mbit/s)	1/32 (Mbit/s)	1/16 (Mbit/s)	19/256 (Mbit/s)	1/8 (Mbit/s)	19/128 (Mbit/s)	1/4 (Mbit/s)
QPSK	1/2	1.4	1.3	1.3	1.3	1.2	1.2	1.1	1.4	1.4	1.4	1.3	1.3	1.3	1.2
	3/5	1.6	1.6	1.6	1.5	1.5	1.4	1.3	1.7	1.7	1.6	1.6	1.5	1.5	1.4
	2/3	1.8	1.8	1.7	1.7	1.6	1.6	1.5	1.9	1.9	1.8	1.8	1.7	1.7	1.5
	3/4	2.1	2.0	2.0	1.9	1.9	1.8	1.7	2.2	2.1	2.0	2.0	1.9	1.9	1.7
	4/5	2.2	2.2	2.1	2.1	2.0	1.9	1.8	2.3	2.2	2.2	2.2	2.1	2.0	1.9
	5/6	2.3	2.2	2.2	2.2	2.1	2.0	1.9	2.4	2.3	2.3	2.3	2.2	2.1	1.9
16-QAM	1/2	2.8	2.7	2.6	2.6	2.5	2.4	2.2	2.9	2.8	2.7	2.7	2.6	2.5	2.3
	3/5	3.3	3.2	3.1	3.1	3.0	2.9	2.7	3.5	3.4	3.3	3.2	3.1	3.0	2.8
	2/3	3.7	3.6	3.5	3.5	3.3	3.2	3.0	3.8	3.8	3.7	3.6	3.5	3.4	3.1
	3/4	4.1	4.0	3.9	3.9	3.7	3.6	3.3	4.3	4.2	4.1	4.1	3.9	3.8	3.5
	4/5	4.4	4.3	4.2	4.1	4.0	3.9	3.6	4.6	4.5	4.4	4.3	4.1	4.1	3.7
	5/6	4.6	4.5	4.4	4.3	4.1	4.0	3.7	4.8	4.7	4.6	4.5	4.3	4.2	3.9
64-QAM	1/2	4.1	4.0	3.9	3.9	3.7	3.6	3.3	4.3	4.2	4.1	4.0	3.9	3.8	3.5
	3/5	5.0	4.8	4.7	4.7	4.4	4.4	4.0	5.2	5.1	4.9	4.9	4.6	4.5	4.2
	2/3	5.5	5.4	5.2	5.2	4.9	4.8	4.5	5.8	5.6	5.5	5.4	5.2	5.1	4.7
	3/4	6.2	6.1	5.9	5.8	5.6	5.5	5.0	6.5	6.3	6.2	6.1	5.8	5.7	5.2
	4/5	6.6	6.5	6.3	6.2	5.9	5.8	5.3	6.9	6.8	6.6	6.5	6.2	6.1	5.6
	5/6	6.9	6.7	6.5	6.5	6.2	6.1	5.6	7.2	7.0	6.8	6.8	6.5	6.3	5.8
256-QAM	1/2	5.5	5.4	5.2	5.2	4.9	4.8	4.5	5.8	5.6	5.5	5.4	5.2	5.1	4.7
	3/5	6.6	6.5	6.3	6.2	5.9	5.8	5.3	6.9	6.8	6.6	6.5	6.2	6.1	5.6
	2/3	7.4	7.2	7.0	6.9	6.6	6.5	6.0	7.7	7.5	7.3	7.2	6.9	6.8	6.2
	3/4	8.3	8.1	7.9	7.8	7.4	7.3	6.7	8.7	8.5	8.2	8.1	7.8	7.6	7.0
	4/5	8.8	8.6	8.4	8.3	7.9	7.8	7.1	9.2	9.0	8.8	8.7	8.3	8.1	7.5
	5/6	9.2	9.0	8.7	8.7	8.3	8.1	7.4	9.6	9.4	9.1	9.0	8.6	8.5	7.8

TABLE A2.7 (end)

Modulation	Code rate	Scattered Pilot Pattern 5 & 6							Scattered Pilot Pattern 7 & 8						
		GIF							GIF						
		1/128 (Mbit/s)	1/32 (Mbit/s)	1/16 (Mbit/s)	19/256 (Mbit/s)	1/8 (Mbit/s)	19/128 (Mbit/s)	1/4 (Mbit/s)	1/128 (Mbit/s)	1/32 (Mbit/s)	1/16 (Mbit/s)	19/256 (Mbit/s)	1/8 (Mbit/s)	19/128 (Mbit/s)	1/4 (Mbit/s)
QPSK	1/2	1.5	1.4	1.4	1.4	1.3	1.3	1.2	1.5	1.4	1.4	1.4	1.3	1.3	1.2
	3/5	1.8	1.7	1.7	1.7	1.6	1.5	1.4	1.8	1.7	1.7	1.7	1.6	1.6	1.4
	2/3	2.0	1.9	1.9	1.8	1.8	1.7	1.6	2.0	1.9	1.9	1.9	1.8	1.7	1.6
	3/4	2.2	2.2	2.1	2.1	2.0	1.9	1.8	2.2	2.2	2.1	2.1	2.0	2.0	1.8
	4/5	2.4	2.3	2.2	2.2	2.1	2.1	1.9	2.4	2.3	2.3	2.2	2.1	2.1	1.9
	5/6	2.5	2.4	2.3	2.3	2.2	2.2	2.0	2.5	2.4	2.4	2.3	2.2	2.2	2.0
16-QAM	1/2	2.9	2.9	2.8	2.8	2.6	2.6	2.4	3.0	2.9	2.8	2.8	2.7	2.6	2.4
	3/5	3.5	3.5	3.4	3.3	3.2	3.1	2.9	3.6	3.5	3.4	3.4	3.2	3.1	2.9
	2/3	3.9	3.8	3.7	3.7	3.5	3.5	3.2	4.0	3.9	3.8	3.7	3.6	3.5	3.2
	3/4	4.4	4.3	4.2	4.2	4.0	3.9	3.6	4.5	4.4	4.2	4.2	4.0	3.9	3.6
	4/5	4.7	4.6	4.5	4.4	4.2	4.1	3.8	4.8	4.7	4.5	4.5	4.3	4.2	3.9
	5/6	4.9	4.8	4.7	4.6	4.4	4.3	4.0	5.0	4.9	4.7	4.7	4.5	4.4	4.0
64-QAM	1/2	4.4	4.3	4.2	4.1	3.9	3.9	3.6	4.4	4.3	4.2	4.2	4.0	3.9	3.6
	3/5	5.3	5.2	5.0	5.0	4.7	4.6	4.3	5.3	5.2	5.1	5.0	4.8	4.7	4.3
	2/3	5.9	5.8	5.6	5.5	5.3	5.2	4.8	5.9	5.8	5.6	5.6	5.3	5.2	4.8
	3/4	6.6	6.5	6.3	6.2	5.9	5.8	5.3	6.7	6.5	6.4	6.3	6.0	5.9	5.4
	4/5	7.1	6.9	6.7	6.6	6.3	6.2	5.7	7.1	7.0	6.8	6.7	6.4	6.3	5.8
	5/6	7.4	7.2	7.0	6.9	6.6	6.5	6.0	7.4	7.3	7.1	7.0	6.7	6.5	6.0
256-QAM	1/2	5.9	5.7	5.6	5.5	5.3	5.2	4.8	5.9	5.8	5.6	5.6	5.3	5.2	4.8
	3/5	7.1	6.9	6.7	6.6	6.3	6.2	5.7	7.1	7.0	6.8	6.7	6.4	6.3	5.8
	2/3	7.9	7.7	7.5	7.4	7.1	6.9	6.4	7.9	7.8	7.5	7.5	7.1	7.0	6.4
	3/4	8.8	8.6	8.4	8.3	7.9	7.8	7.1	8.9	8.7	8.5	8.4	8.0	7.9	7.2
	4/5	9.4	9.2	9.0	8.9	8.5	8.3	7.6	9.5	9.3	9.1	9.0	8.6	8.4	7.7
	5/6	9.8	9.6	9.3	9.2	8.8	8.6	7.9	9.9	9.7	9.4	9.3	8.9	8.7	8.0

Annex 3

Nyquist time for frequency and time interpolation vs. guard interval

The theoretical time delay which a signal path may have with regard to the first signal path arriving at the receiver in order to contribute at least partially constructively is the Nyquist time (labelled T_n or T_p). For DVB-T this time is $T_u/3$, where T_u designates the useful symbol length. For DVB-T2 this theoretical limit depends on the chosen scattered pilot pattern. In § 3.5 the theoretical background was explained and the theoretical limits for selected implementation scenarios were given.

Table A3.1 gives a comprehensive overview of the Nyquist time for the available combinations of guard interval and scattered pilot pattern in SISO mode.

TABLE A3.1

Nyquist time for frequency and time interpolation vs. guard interval (SISO mode, 8 MHz bandwidth, elementary period $T = 0.1094 \mu\text{s}$, T_u : useful symbol length)

GIF		1/128	1/32	1/16	19/256	1/8	19/128	1/4
32k ($T_u = 3584 \mu\text{s}$)	GI	28.0 μs	112.0 μs	224.0 μs	266.0 μs	448.0 μs	532.0 μs	n/a
	T_n (PP1)	n/a	n/a	n/a	n/a	n/a	n/a	n/a
	T_n (PP2)	n/a	n/a	597.3 μs	597.3 μs	597.3 μs	597.3 μs	n/a
	T_n (PP3)	n/a	n/a	n/a	n/a	n/a	n/a	n/a
	T_n (PP4)	n/a	298.7 μs	298.7 μs	298.7 μs	n/a	n/a	n/a
	T_n (PP5)	n/a	n/a	n/a	n/a	n/a	n/a	n/a
	T_n (PP6)	n/a	149.3 μs	n/a	n/a	n/a	n/a	n/a
	T_n (PP7)	149.3 μs	n/a	n/a	n/a	n/a	n/a	n/a
	T_n (PP8)	n/a	n/a	597.3 μs	597.3 μs	597.3 μs	597.3 μs	n/a
16k ($T_u = 1792 \mu\text{s}$)	GI	14.0 μs	56.0 μs	112.0 μs	133.0 μs	224.0 μs	266.0 μs	448.0 μs
	T_n (PP1)	n/a	n/a	n/a	n/a	n/a	n/a	597.3 μs
	T_n (PP2)	n/a	n/a	298.7 μs	298.7 μs	298.7 μs	298.7 μs	n/a
	T_n (PP3)	n/a	n/a	n/a	n/a	298.7 μs	298.7 μs	n/a
	T_n (PP4)	n/a	149.3 μs	149.3 μs	149.3 μs	n/a	n/a	n/a
	T_n (PP5)	n/a	n/a	149.3 μs	149.3 μs	n/a	n/a	n/a
	T_n (PP6)	n/a	74.7 μs	n/a	n/a	n/a	n/a	n/a
	T_n (PP7)	74.7 μs	74.7 μs	n/a	n/a	n/a	n/a	n/a
	T_n (PP8)	n/a	n/a	298.7 μs	298.7 μs	298.7 μs	298.7 μs	298.7 μs
8k ($T_u = 896 \mu\text{s}$)	GI	7.0 μs	28.0 μs	56.0 μs	66.5 μs	112.0 μs	133.0 μs	224.0 μs
	T_n (PP1)	n/a	n/a	n/a	n/a	n/a	n/a	298.7 μs
	T_n (PP2)	n/a	n/a	n/a	n/a	149.3 μs	149.3 μs	n/a
	T_n (PP3)	n/a	n/a	n/a	n/a	149.3 μs	149.3 μs	n/a
	T_n (PP4)	n/a	74.7 μs	74.7 μs	74.7 μs	n/a	n/a	n/a
	T_n (PP5)	n/a	n/a	74.7 μs	74.7 μs	n/a	n/a	n/a
	T_n (PP6)	n/a	n/a	n/a	n/a	n/a	n/a	n/a
	T_n (PP7)	37.3 μs	37.3 μs	n/a	n/a	n/a	n/a	n/a
	T_n (PP8)	n/a	n/a	74.7 μs	149.3 μs	149.3 μs	149.3 μs	149.3 μs

TABLE A3.1 (*end*)

GIF		1/128	1/32	1/16	19/256	1/8	19/128	1/4
4k ($T_u = 448 \mu\text{s}$)	GI	<i>n/a</i>	14.0 μs	28.0 μs	<i>n/a</i>	56.0 μs	<i>n/a</i>	112.0 μs
	T_n (PP1)	<i>n/a</i>	<i>n/a</i>	<i>n/a</i>	<i>n/a</i>	<i>n/a</i>	<i>n/a</i>	149.3 μs
	T_n (PP2)	<i>n/a</i>	<i>n/a</i>	<i>n/a</i>	<i>n/a</i>	74.7 μs	<i>n/a</i>	<i>n/a</i>
	T_n (PP3)	<i>n/a</i>	<i>n/a</i>	<i>n/a</i>	<i>n/a</i>	74.7 μs	<i>n/a</i>	<i>n/a</i>
	T_n (PP4)	<i>n/a</i>	37.3 μs	37.3 μs	<i>n/a</i>	<i>n/a</i>	<i>n/a</i>	<i>n/a</i>
	T_n (PP5)	<i>n/a</i>	<i>n/a</i>	37.3 μs	<i>n/a</i>	<i>n/a</i>	<i>n/a</i>	<i>n/a</i>
	T_n (PP6)	<i>n/a</i>	<i>n/a</i>	<i>n/a</i>	<i>n/a</i>	<i>n/a</i>	<i>n/a</i>	<i>n/a</i>
	T_n (PP7)	<i>n/a</i>	18.7 μs	<i>n/a</i>	<i>n/a</i>	<i>n/a</i>	<i>n/a</i>	<i>n/a</i>
	T_n (PP8)	<i>n/a</i>	<i>n/a</i>	<i>n/a</i>	<i>n/a</i>	<i>n/a</i>	<i>n/a</i>	<i>n/a</i>
2k ($T_u = 224 \mu\text{s}$)	GI	<i>n/a</i>	7.0 μs	14.0 μs	<i>n/a</i>	28.0 μs	<i>n/a</i>	56.0 μs
	T_n (PP1)	<i>n/a</i>	<i>n/a</i>	<i>n/a</i>	<i>n/a</i>	<i>n/a</i>	<i>n/a</i>	74.7 μs
	T_n (PP2)	<i>n/a</i>	<i>n/a</i>	<i>n/a</i>	<i>n/a</i>	37.3 μs	<i>n/a</i>	<i>n/a</i>
	T_n (PP3)	<i>n/a</i>	<i>n/a</i>	<i>n/a</i>	<i>n/a</i>	37.3 μs	<i>n/a</i>	<i>n/a</i>
	T_n (PP4)	<i>n/a</i>	18.7 μs	18.7 μs	<i>n/a</i>	<i>n/a</i>	<i>n/a</i>	<i>n/a</i>
	T_n (PP5)	<i>n/a</i>	<i>n/a</i>	18.7 μs	<i>n/a</i>	<i>n/a</i>	<i>n/a</i>	<i>n/a</i>
	T_n (PP6)	<i>n/a</i>	<i>n/a</i>	<i>n/a</i>	<i>n/a</i>	<i>n/a</i>	<i>n/a</i>	<i>n/a</i>
	T_n (PP7)	<i>n/a</i>	9.3 μs	<i>n/a</i>	<i>n/a</i>	<i>n/a</i>	<i>n/a</i>	<i>n/a</i>
	T_n (PP8)	<i>n/a</i>	<i>n/a</i>	<i>n/a</i>	<i>n/a</i>	<i>n/a</i>	<i>n/a</i>	<i>n/a</i>
1k ($T_u = 112 \mu\text{s}$)	GI	<i>n/a</i>	<i>n/a</i>	7.0 μs	<i>n/a</i>	14.0 μs	<i>n/a</i>	28.0 μs
	T_n (PP1)	<i>n/a</i>	<i>n/a</i>	<i>n/a</i>	<i>n/a</i>	<i>n/a</i>	<i>n/a</i>	37.3 μs
	T_n (PP2)	<i>n/a</i>	<i>n/a</i>	<i>n/a</i>	<i>n/a</i>	18.7 μs	<i>n/a</i>	<i>n/a</i>
	T_n (PP3)	<i>n/a</i>	<i>n/a</i>	<i>n/a</i>	<i>n/a</i>	18.7 μs	<i>n/a</i>	<i>n/a</i>
	T_n (PP4)	<i>n/a</i>	<i>n/a</i>	9.3 μs	<i>n/a</i>	<i>n/a</i>	<i>n/a</i>	<i>n/a</i>
	T_n (PP5)	<i>n/a</i>	<i>n/a</i>	9.3 μs	<i>n/a</i>	<i>n/a</i>	<i>n/a</i>	<i>n/a</i>
	T_n (PP6)	<i>n/a</i>	<i>n/a</i>	<i>n/a</i>	<i>n/a</i>	<i>n/a</i>	<i>n/a</i>	<i>n/a</i>
	T_n (PP7)	<i>n/a</i>	<i>n/a</i>	<i>n/a</i>	<i>n/a</i>	<i>n/a</i>	<i>n/a</i>	<i>n/a</i>
	T_n (PP8)	<i>n/a</i>	<i>n/a</i>	<i>n/a</i>	<i>n/a</i>	<i>n/a</i>	<i>n/a</i>	<i>n/a</i>

NOTE – Table A3.1 provides equalisation interval durations for an ideal receiver. For planning purposes it should be assumed that 57/64 (89.1%) of these ideal limits could be achieved by practical receivers (see § 3.5).

From the Table it can be seen that in SISO mode (not in MISO mode) combinations of guard interval and scattered pilot pattern are available for which the Nyquist time is smaller than the guard interval. These are marked in red and it is questionable whether these combinations are practical.

Annex 4

Derivation and comparison of C/N valuesA4.1 Raw values of C/N for the derivation of the Rice and Rayleigh Channel Case

The DVB-T2 Implementation Guideline [TS 102 831] also provides C/N figures for a Ricean and a static Rayleigh channel, derived from simulations.

TABLE A4.1

Required raw $(C/N)_0$ to achieve a $BER = 1 \times 10^{-7}$ after LDPC decoding
LDPC block length: 64800 bits (from [TS 102 831])

			Required $(C/N)_0$ (dB) for $BER = 1 \times 10^{-7}$ after LDPC decoding			
Constellation	Code rate	Spectral efficiency (see Note 2)	Gaussian channel (AWGN)	Ricean channel (F_1)	Rayleigh channel (P_1)	0 dB echo channel @ 90% GI
QPSK	1/2	0.99	1.0	1.2	2.0	1.7
QPSK	3/5	1.19	2.3	2.5	3.6	3.2
QPSK	2/3	1.33	3.1	3.4	4.9	4.5
QPSK	3/4	1.49	4.1	4.4	6.2	5.7
QPSK	4/5	1.59	4.7	5.1	7.1	6.6
QPSK	5/6	1.66	5.2	5.6	7.9	7.5
16-QAM	1/2	1.99	6.0	6.2	7.5	7.2
16-QAM	3/5	2.39	7.6	7.8	9.3	9.0
16-QAM	2/3	2.66	8.9	9.1	10.8	10.4
16-QAM	3/4	2.99	10.0	10.4	12.4	12.1
16-QAM	4/5	3.19	10.8	11.2	13.6	13.4
16-QAM	5/6	3.32	11.4	11.8	14.5	14.4
64-QAM	1/2	2.98	9.9	10.2	11.9	11.8
64-QAM	3/5	3.58	12.0	12.3	14.0	13.9
64-QAM	2/3	3.99	13.5	13.8	15.6	15.5
64-QAM	3/4	4.48	15.1	15.4	17.7	17.6
64-QAM	4/5	4.78	16.1	16.6	19.2	19.2
64-QAM	5/6	4.99	16.8	17.2	20.2	20.4
256-QAM	1/2	3.98	13.2	13.6	15.6	15.7
256-QAM	3/5	4.78	16.1	16.3	18.3	18.4
256-QAM	2/3	5.31	17.8	18.1	20.1	20.3
256-QAM	3/4	5.98	20.0	20.3	22.6	22.7
256-QAM	4/5	6.38	21.3	21.7	24.3	24.5
256-QAM	5/6	6.65	22.0	22.4	25.4	25.8

Notes to Table A4.1

NOTE 1 – Figures in italics are approximate values.

NOTE 2 – Spectral efficiency does not take into account loss due to signalling/synchronization/sounding and guard interval.

NOTE 3 – The BER targets are discussed in more detail in [TS 102 831].

NOTE 4 – The expected implementation loss due to real channel estimation needs to be added to the above figures. This value will be significantly less than the corresponding figure for DVB-T in some cases, due to better optimization of the boosting and pattern densities for DVB-T2.

NOTE 5 – Entries shaded blue are results from a single implementation. All other results are confirmed by multiple implementations.

The DVB-T2 OFDM parameters used for these simulations were chosen so as to be as similar as possible to those for DVB-T. These parameters are as follows: the FFT size is 8k with a guard interval of 1/32, and the bandwidth is 8 MHz with normal carrier mode. Rotated constellations were used and PAPR (Peak to Average Power Ratio) techniques were not applied. The simulations assumed ideal conditions, i.e. ideal synchronization and ideal channel estimation.

In § 2.5 these raw values serve as a reference (for the Gaussian case) and as a basis to derive the difference DELTA of C/N_{Gauss} and C/N_{Rice} and $C/N_{Rayleigh}$, respectively. They are given in Table A4.1.

A4.2 Comparison of C/N values calculated according to the methodology of § 2.5 and measurement results

In this section, results of available laboratory and field measurements are compared with the C/N values calculated according to the methodology proposed in § 2.5.

These results should be regarded as an initial assessment of the validity of the proposed approach. Final confirmation can only be achieved when further measurements of additional receivers are available. This is in particular the case for the time-variant Rayleigh channel. It can be expected that receivers which are optimized for portable and mobile reception will show an improved performance.

Table A4.2, overleaf, sets out IRT's laboratory measurements [EDP247] for a Gaussian (Gauss), a static Rayleigh (RL20stat) channel and a slowly time-variant Rayleigh (TU50 0.4) channel. These measurements are an update of previous ones taken by IRT [EDP166]; in particular, for the time variant Rayleigh channel with the ESR5 criterion applied. Eight different DVB-T2 configurations were investigated (the numbering convention "Mode x" is not consecutive since they were selected from a larger number of configurations). The measurements are based on a set of 4 receivers mainly designed for fixed reception.

For the Gaussian channel, the calculated C/N s (according to § 2.5) are 1.5-2.0 dB higher than the measured values whereas the simulated values from the implementation guidelines [TS 102 831] are 0.5-1.5 dB lower.

A similar tendency can be observed for the static Rayleigh channel. The calculated values are about 1 dB higher than the measured values while the simulated values are 1.5-2 dB lower.

A large increase of the C/N value is found for the time-variant Rayleigh channel as compared to the static case. It is on average 6.6 dB. However, this finding is to be treated with caution as only one receiver was measured and it may not be representative of the wider range of receivers available. Furthermore the receiver was designed for fixed reception – receivers optimized for mobile reception, which may be available in the future, can be expected to perform better.

TABLE A4.2

Calculated C/N values (according to § 2.5) vs. measured C/N values from [EDP247]

DVB-T2 Mode		1	2	3	4	5	6	8	12	
Constellation		16-QAM	64-QAM	64-QAM	256-QAM	64-QAM	256-QAM	16-QAM	16-QAM	
Code rate		3/5	2/3	2/3	1/2	3/4	3/5	1/2	2/3	
Carrier		8k	8k	16k	16k	16k	16k	8k	16k	

C/N in Gaussian channel										Median
Simulation *1	dB	7.6	13.5	13.5	13.2	15.1	16.1	6.0	8.9	dB
Calculated C/N *2	dB	10.1	16.2	16.2	16.6	17.3	19.0	8.7	11.4	
Average measured Rx1 to Rx4	dB	8.0	14.4	14.0	15.3	15.6	17.5	6.6	9.5	
Difference to simulation	dB	0.4	0.8	0.5	1.8	0.5	1.4	0.6	0.6	0.6
Difference to calculated C/N *2	dB	-2.1	-1.9	-2.2	-1.6	-1.7	-1.5	-2.1	-1.9	-1.9

C/N in static Rayleigh channel RL 20 ANX B										Median
Simulation *1	dB	9.3	15.6	15.6	15.6	17.7	18.3	7.5	10.8	
Calculated C/N *2	dB	11.8	18.3	18.3	19.1	20.0	21.2	10.2	13.4	
Average measured Rx1 to Rx4	dB	10.9	17.2	17.1	17.8	19.1	20.1	9.4	12.3	
Difference to simulation	dB	1.6	1.6	1.5	2.2	1.4	1.8	1.9	1.5	1.6
Difference to calculated C/N *2	dB	-0.9	-1.1	-1.2	-1.3	-0.9	-1.1	-0.8	-1.1	-1.1

C/N in time-variant Rayleigh channel TU50 20 Path at 0.4 km/h (Doppler 0.25 Hz)										Median
ESR5 quality criterion fulfilled for 99% of time (measurement time 15 minutes)										
Rx1	dB	16.9	23.7	23.1	24.6	25.6	26.9	14.8	18.3	
C/N time variation median value	dB	14.8	21.3	20.9	21.6	23.2	24.5	12.7	16.2	
C/N time variation standard deviation	dB	0.9	1.0	1.0	1.3	1.0	1.0	0.9	0.9	

Difference to static simulation	dB	7.6	8.1	7.5	9.0	7.9	8.6	7.3	7.5	7.7
Difference to static measurement	dB	6.0	6.5	6.0	6.8	6.5	6.8	5.5	6.0	6.3

*1 ETSI TS 102 831 V1.1.1 Table 44.

*2 EBU Tech 3348 V2.0 Table A4.2.

A trial in the northern part of Germany [Nord2012] took field measurements for selected DVB-T2 modes. The results can be found in Table A4.3, including a comparison with the simulated results from the implementation guideline and the proposed values of § 2.5.

Firstly, the results for the 16k FFT are examined. There is a small difference of about 1 dB between the static and the mobile case for the low Doppler frequency, 30 Hz, which corresponds to about 50 km/h at UHF frequencies. The proposed Rayleigh values fit very well to these mobile values whereas the implementation guideline underestimates them by 2.5 to 4 dB. For even higher Doppler frequencies the measured C/N increases by between 0.5 dB and 7 dB depending on the code rate which is due to Doppler degradation.

Secondly, the 32k FFT case is examined. Here Doppler degradation is very prominent. Even for a Doppler frequency of 30 Hz an increase of the C/N values of 4 to 15 dB is observed as compared to the static case. This dependency of C/N values for mobile reception on the FFT mode is not taken into account in the proposed methodology of § 2.5, and has to be updated as soon as more measurement results for mobile reception are available.

However, as for the previous laboratory measurements, the particular C/N values of [Nord2012] for mobile reception should be treated with caution. Presently (Autumn 2013) no specific DVB-T2 receivers optimized for mobile reception are in the market. Definitive planning figures for mobile reception must wait until measurements of such devices are available.

TABLE A4.3

C/N values (in dB) from [Nord2012] for a static Rayleigh channel and a time-variant Rayleigh channel with 30 Hz and 80 Hz Doppler frequency

		32k_ext, GI=1/16, PP2 (portable & mobile)		16k_ext, GI=19/128, PP2 (portable & mobile)			(independent of FFT and GI) PP2	
Doppler frequency		Static	< 30 Hz	Static	< 30 Hz	< 80 Hz	Static Rayleigh	
							IG* simulated	§ 2.5 Calculated
Constellation	Code rate							
16QAM	1/2	9.0	12.7		10.2	10.8	6.9	10.2
16QAM	2/3			12.4	13.5	16.5	11.1	13.3
64QAM	1/2			13.4	14.8	17.3	11.0	15.1
64QAM	3/5			16.4	17.0	24.4	14.4	16.9
64QAM	2/3	17.0	28.6	18.2	18.9		16.1	18.4
64QAM	3/4	19.7	34.4				18.2	20.5

*: Implementation Guidelines [TS 102 831].

A second comparison uses results of measurements [EDP135, Ei2010, Ei2011] of the University of the Basque Country. These are field and laboratory measurements for fixed reception. Channel classification is made based on the standard deviation of spectral amplitudes of the received signal according to Recommendation ITU-R SM.1875.

The measurements are taken with the following receivers:

Table A4.4: Two consumer receivers.

Table A4.5: Professional receiver (Enensys)

Table A4.6: Software receiver.

The Nordig Requirements for receivers [NorDig2013] are also included in Table A4.5 for the available channels.

It must be noted that the channel models are not the same:

- Nordig 0 dB echo channel does not include frequency offset between paths.
- In laboratory tests, Ricean and Rayleigh channels are obtained by two paths of different attenuation and a delay of 50% of the GI.
- In field trials, multipath is in some cases produced by SFN configurations, with one main transmitter and a gap-filler, and in other cases only by the propagation channel.

All the measured configurations employ 64- or 256-QAM modulations, pilot patterns PP7 with 1/128 GIF or PP4 with 1/16 GIF, 8 MHz bandwidth with extended mode and rotated constellations.

Table A4.4 shows the results for the two consumer receivers.

TABLE A4.4
Comparison of calculated C/N values (according to § 2.5) and
measured C/N values from [EDP135]

32k FFT, 8 MHz Extended mode, Pilot Pattern PP4, Ricean channel			
Modulation	Code Rate	Measured C/N (dB)	Calculated C/N_{Rice} (dB)
64-QAM	1/2	11.9	12.9
64-QAM	3/5	13.4	14.8
64-QAM	2/3	14.9	16.1
64-QAM	3/4	16.2	17.6
64-QAM	4/5	17.5	18.9
64-QAM	5/6	18.1	19.4
256-QAM	1/2	16.1	17.0
256-QAM	3/5	18.3	19.2
256-QAM	2/3	19.7	20.8
256-QAM	3/4	22.0	22.8
256-QAM	4/5	23.2	24.4
256-QAM	5/6	24.2	25.2

The calculated C/N values are slightly higher than the measured values by about 1 dB.

Table A4.5 shows the results for the professional receiver.

TABLE A4.5

Comparison of calculated *C/N* values (according to § 2.5), NorDig values, and measured *C/N* values from lab tests and field trials from [Ei2011]

32k FFT, 8 MHz Extended mode, Pilot pattern PP4, GIF 1/16													
QAM		64	64	64	64	64	64	256	256	256	256	256	256
Code Rate		1/2	3/5	2/3	3/4	4/5	5/6	1/2	3/5	2/3	3/4	4/5	5/6
Gaussian	Simulation	9.9	12.0	13.5	15.1	16.1	16.8	13.2	16.1	17.8	20.0	21.3	22.0
	NorDig	12.6	14.4	15.7	17.3	18.3	18.9	16.5	18.9	20.4	22.4	23.8	24.6
	Lab	10.9	12.8	14.0	15.6	16.6	17.3	15.0	17.4	18.7	20.8	22.3	23.1
	Field	11.2	13.0	14.3	15.9	17.0	17.6	15.3	17.8	19.2	21.4	22.8	23.7
	Calculated	12.6	14.5	15.8	17.3	18.3	19.0	16.6	19.0	20.4	22.4	23.9	24.7
Ricean	Simulation	10.2	12.3	13.8	15.4	16.6	17.2	13.6	16.3	18.1	20.3	21.7	22.4
	Lab	11.3	13.1	14.4	16.0	17.1	17.8	15.3	17.7	19.1	21.4	22.7	25.8
	Field	11.4	13.4	14.7	16.6	17.6	18.3	15.8	18.4	19.8	22.3	24.2	24.8
	Calculated	12.9	14.8	16.1	17.6	18.9	19.4	17.0	19.2	20.8	22.8	24.4	25.2
Rayleigh	Simulation	11.9	14.0	15.6	17.7	19.2	20.2	15.6	18.3	20.1	22.6	24.3	25.4
	Lab	12.9	14.9	16.5	18.5	20.0	21.0	17.0	19.5	21.3	23.8	25.8	26.2
	Field	13.4	15.6	17.4	19.6	21.4	22.1	17.9	20.7	22.7	25.9	28.5	28.9
	Calculated	14.7	16.5	17.9	20.0	21.6	22.6	19.1	21.3	22.9	25.4	27.5	28.9
0 dB echo	Simulation	11.8	13.9	15.5	17.6	19.2	20.4	15.7	18.4	20.3	22.7	24.5	25.8
	Nordig	15.5	17.6	19.2	21.6	23.5	25.0	20.2	22.6	24.6	27.4	30.2	32.7
	Lab	13.7	15.9	17.9	20.5	22.6	24.2	18.1	20.8	22.7	25.7	28.6	32.1
32k FFT, 8 MHz Extended mode, Pilot pattern PP7, GIF 1/128													
QAM								256	256	256	256	256	256
Code Rate								1/2	3/5	2/3	3/4	4/5	5/6
Gaussian	Simulation							13.2	16.1	17.8	20.0	21.3	22.0
	Nordig							15.9	18.3	19.7	21.7	23.2	23.9
	Lab							15.0	17.4	18.9	20.8	22.4	23.1
	Field							15.2	17.7	19.0	21.3	22.8	23.7
	Calculated							15.9	18.2	19.7	21.7	23.1	23.9
Ricean	Simulation							13.6	16.3	18.1	20.3	21.7	22.4
	Lab							15.5	17.8	19.1	21.3	22.6	23.5
	Field							15.6	18.2	19.7	22.2	23.6	24.8
	Calculated							16.3	18.4	20.0	22.0	23.6	24.4
Rayleigh	Simulation							15.6	18.3	20.1	22.6	24.3	25.4
	Lab							17.0	19.6	21.4	23.8	25.8	27.4
	Field							17.8	20.9	22.2	27.1	28.1	32.6
	Calculated							18.3	20.5	22.1	24.6	26.6	28.0
0 dB echo	Simulation							15.7	18.4	20.3	22.7	24.5	25.8
	Nordig							19.5	22.0	23.9	26.6	29.3	31.6
	Lab							18.9	21.7	23.2	26.1	29.2	31.9

As indicated in § 2.5, the calculated C/N are identical to the NorDig figures for the Gaussian channel within 0.1 dB.

For the Gaussian channel, the calculated C/N are about 1 to 2 dB higher than the measured values from laboratory and field trials. For the Ricean channel the calculated C/N are higher by 0-1 dB than the measured figures, and for the Rayleigh channel the calculated C/N fit quite good with the measured C/N . In the case of DVB-T2 mode 256-QAM, PP7, for the Rayleigh channel, even higher values have been measured than calculated by the methodology of § 2.5.

These results are in line with the findings of the IRT measurements which indicate that the calculated C/N figures are slightly conservative with regard to the Gaussian channel. They fit reasonably well in the Ricean and the Rayleigh case.

Table A4.6 shows the results for the software receiver.

TABLE A4.6
Comparison of calculated C/N values (according to § 2.5)
and measured C/N values from [Ei2010]

32k FFT, 8 MHz Extended mode, Pilot pattern PP7, Ricean channel			
Modulation	Code Rate	Measured C/N (dB)	Calculated C/N_{Rice} (dB)
64-QAM	3/4	16.0	16.9
256-QAM	3/5	18.0	18.4

Again, the calculated values are 0.5-1 dB higher than the measured values.

The overall calculated C/N figures are slightly conservative for many T2 modes particularly for the Gaussian channel. It has to be kept in mind that the measurement results are yet based on a relatively small number of receivers.

Annex 5

DVB-T2-Lite

A5.1 Introduction

DVB-T2-Lite is a system profile which was added in an annex of version 1.3.1 of the DVB-T2 specification in November 2011 [EN 302 755-V1.3.1]. It is particularly designed for mobile and handheld reception. With T2-Lite the set of possible system configurations is restricted as compared to the full range of options provided by DVB-T2 as described in the main part of the standard. In order to distinguish T2-Lite from this full range of options the latter profile is called T2-Base. However, T2-Lite also adds some new options that are not available in T2-Base. Thus T2-Base does not describe the full superset of DVB-T2 options that now exist.

In general, T2-Lite reduces the complexity that is required for the reception of only T2-Lite services, serving to reduce the cost and power consumption for receivers designed for handheld and mobile reception.

In § A5.2 the differences between T2-Base and T2-Lite are listed as far as they are relevant for frequency and network planning. § A5.3 describes how the T2-Lite data stream can be integrated in the DVB-T2 multiplex. § A5.4 and § A5.5 give details of system and planning parameters, although for C/N and protection ratios only limited information is currently publicly available. § A5.6 discusses some possible implementation scenarios and practical implementation aspects.

An update of the DVB-T2 implementation guideline including DVB-T2-Lite aspects will soon be made available by ETSI.

A5.2 Differences between T2-Base and T2-Lite

Differences between DVB-T2-Lite and DVB-T2-Base relevant for planning are:

- Additional, more robust code rates 1/3 and 2/5 are available
- Sensitive code rates 4/5 and 5/6 are omitted
- 256-QAM modulation is possible, but not with code rates 2/3 and 3/4, and no rotated constellation is possible with 256-QAM
- The maximum data rate is restricted to 4 Mbit/s
- FFT sizes 1k and 32k are omitted
- Pilot pattern PP8 is not possible
- Long FEC (64k) is omitted
- Only a reduced time interleaving memory is available
- The number of combinations of FFT size, GI and PP is restricted
- Additional optional error protection is available (scrambling of L1 post-signalling)
- Longer FEF blocks are possible (up to 1 000 ms)

A5.3 DVB-T2-Lite signal structure

In principle, a combination of T2-Lite and T2-Base services is achieved by means of the FEF. The T2-Lite profile is signalled to the receiver via the P1 preamble.

There are several possibilities for a T2-Lite transmission.

The simplest case is that the T2-Lite signal is transmitted as a stand-alone signal, i.e. no combination with T2-Base is required.

For the combination of T2-Lite (T2L) and T2-Base (T2B) T2-Base is transmitted in the FEF of T2-Lite and vice versa. This is shown in Figure A5.1.

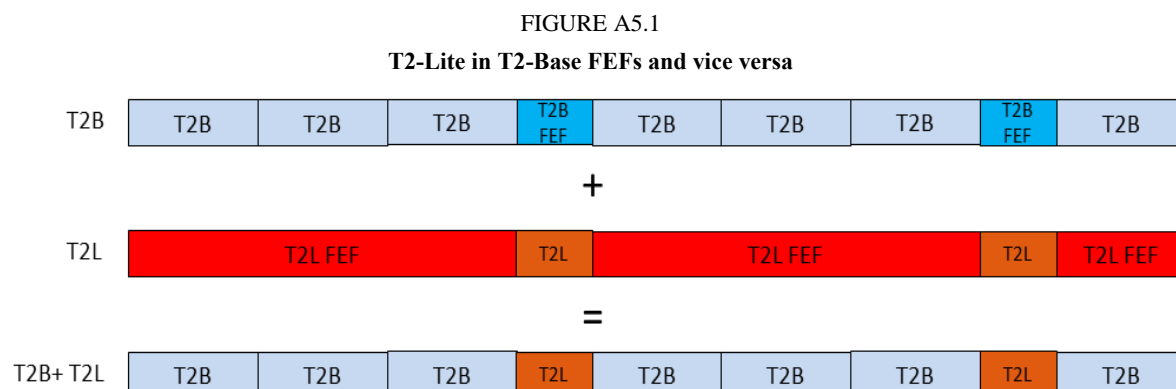

In the example of Figure A5.1 the increase of the FEF block length in T2-Lite is employed in order to accommodate the long T2-Base blocks.

It is also possible to indicate, in L1-pre signalling ('T2_BASE_LITE' bit), that the current T2-base profile signal is compatible with the T2-LITE profile, which should allow an appropriately designed T2-Lite receiver to demodulate this signal. In this way one can address, with the same signal, legacy T2 receivers that do not understand T2-Lite, and at the same time T2-Lite receivers.

A5.4 DVB-T2-Lite system parameters

As described in § A5.2, T2-Lite allows for a slightly different set of possible combination of DVB-T2 parameters. It is to be recalled that these possible combinations are not simply a subset of the T2-Base options but also provide additional options.

TABLE A5.1

**Possible combination of modulation and code rate
for DVB-T2-Lite (from [EN 302 755-V1.3.1])**

Code rate	QPSK	16-QAM	64-QAM	256-QAM
1/3	Yes	Yes	Yes	Yes, but no rotated constellation
2/5	Yes	Yes	Yes	Yes, but no rotated constellation
1/2	Yes	Yes	Yes	Yes, but no rotated constellation
3/5	Yes	Yes	Yes	Yes, but no rotated constellation
2/3	Yes	Yes	Yes	No
3/4	Yes	Yes	Yes	No

Table A5.1 gives an overview of the possible combinations of modulation scheme and code rate. For 256-QAM some combinations are possible, but not with a simultaneous use of the rotated constellation mode.

TABLE A5.2

Scattered pilot pattern to be used for T2-Lite for each allowed combination of FFT size and guard interval in SISO mode (from [EN 302 755-V1.3.1])

FFT size	Guard interval						
	1/128	1/32	1/16	19/256	1/8	19/128	1/4
16k	PP7	PP7 PP6	PP4 PP5	PP2 PP4 PP5	PP2 PP3	PP2 PP3	PP1
8k	PP7	PP7 PP4	PP4 PP5	PP4 PP5	PP2 PP3	PP2 PP3	PP1
4k, 2k	<i>n/a</i>	PP7 PP4	PP4 PP5	<i>n/a</i>	PP2 PP3	<i>n/a</i>	PP1

Tables A5.2 and A5.3 give the possible combinations of FFT size, guard interval and scattered pilot pattern for the SISO and the MISO mode.

TABLE A5.3

Scattered pilot pattern to be used for T2-Lite for each allowed combination of FFT size and guard interval in MISO mode (from [EN 302 755-V1.3.1])

FFT size	Guard interval						
	1/128	1/32	1/16	19/256	1/8	19/128	1/4
16k	PP4 PP5	PP4	PP3	PP3	PP1	PP1	<i>n/a</i>
8k	PP4 PP5	PP4 PP5	PP3	PP3	PP1	PP1	<i>n/a</i>
4k, 2k	<i>n/a</i>	PP4 PP5	PP3	<i>n/a</i>	PP1	<i>n/a</i>	<i>n/a</i>

A5.5 DVB-T2-Lite planning parameters

Other than for T2-Base, for T2-Lite only an LDPC block length of 16 200 bits is available. C/N values for this block length differ slightly from those for 64 800 bits block length which were taken as a reference in § 2.5 for the derivation of C/N values for T2-Base. For details see Tables 44 and 45 in the Implementation Guidelines [TS 102 831].

In addition, to date no simulation or measurement results are publicly available for the additional code rates 1/3 and 2/5. However, preliminary measurement results of these modes by RAI/Rai Way, which are not yet public, allow for an extrapolation to gain also raw values for DVB-T2-Lite modes with code rates 1/3 and 2/5. These raw C/N figures for an AWGN channel together with the raw C/N figures from the implementation guidelines for a LDPC block length of 16 200 bits cover all T2-Lite modes and are given in Table A5.4.

C/N values and protection ratios for frequency and network planning may then be calculated as described in § 2.5 and § 3.4.

For Ricean and (static) Rayleigh channels further correction factors for T2-Lite modes with code rates 1/3 and 2/5 are required, beyond those already available for T2-Base in Table 2.13. They are derived by extrapolation of the correction factors in this table and are given in Table A5.5.

TABLE A5.4

**Raw C/N values for DVB-T2-Lite for a Gaussian Channel (AWGN channel)
(from Table 45 in [TS 102 831] and
extrapolation by means of measurement results from RAI/Rai Way)**

Constellation	Code rate	Gaussian Channel $C/N_{\text{Gauss-raw}}$ (dB)
QPSK	1/3	-0.9
QPSK	2/5	0.1
QPSK	1/2	0.7
QPSK	3/5	2.5
QPSK	2/3	3.4
QPSK	3/4	4.3
16-QAM	1/3	3.7
16-QAM	2/5	4.9
16-QAM	1/2	5.5
16-QAM	3/5	7.9
16-QAM	2/3	9.1
16-QAM	3/4	10.3
64-QAM	1/3	7.2
64-QAM	2/5	8.6
64-QAM	1/2	9.2
64-QAM	3/5	12.3
64-QAM	2/3	13.8
64-QAM	3/4	15.5
256-QAM	1/3	10.3
256-QAM	2/5	11.9
256-QAM	1/2	12.6
256-QAM	3/5	16.9

TABLE A5.5

Increase DELTA (dB) of C/N for Rice and static Rayleigh channels with regard to a Gaussian channel for DVB-T2-Lite modes with code rates 1/3 and 2/5

Constellation	Code Rate	$\text{DELTA}_{\text{Rice}}$ (dB)	$\text{DELTA}_{\text{Rayleigh}}$ (dB)
QPSK	1/3	0.2	0.7
QPSK	2/5	0.2	0.8
16-QAM	1/3	0.2	1.2
16-QAM	2/5	0.2	1.3
64-QAM	1/3	0.3	1.8
64-QAM	2/5	0.3	1.9
256-QAM	1/3	0.3	2.3
256-QAM	2/5	0.3	2.3

A5.6 Implementation aspects and implementation scenarios

T2-Lite has the same SFN capability as T2-Base.

To update a T2-Base transmitter to T2-Lite a firmware update of the exciter should normally be sufficient.

With T2-Lite it is possible to use different FFT sizes within one RF channel. This allows for a more flexible mixture between high data rate services and handheld/mobile services.

The additional T2-Lite modes allow for an even better provision of mobile and handheld services.

Possible implementation scenarios are:

- T2-Lite multiplexes particularly designed for services for portable/handheld/mobile reception.
- Simulcast of T2-Base services with T2-Lite in order to provide additional coverage for handheld, deep indoor or mobile reception but with a lower quality.
- To provide in one multiplex different services particularly designed for high data rate programmes on one hand and for handheld reception on the other hand.

Annex 6

Further understanding the DVB-T2 Equalisation Interval

Section 3.5 sets out a method for determining the useful and interfering portions of echoes of various delays, including those beyond the guard interval. An integral part of the model is the concept of the Equalisation Interval (EI). According to the model, echoes beyond the guard interval, but within EI, contribute partially as useful signals, and partially as interferers – the extent of which is dependent on their delays relative to the FFT window position. The interfering potential of a signal within EI increases with a lengthening delay, for a given FFT window position, while the useful portion decreases. An abrupt transition to a fully interfering signal takes place at the edges of EI.

Figure 3.1, reproduced below as Figure A6.1, shows the weighting of the useful contribution and the sharp transition at the edge of EI (shown as T_p below) for one particular receiver positioning of the EI. It should be noted that the EI may be positioned independently of the FFT window position and that the symmetry in Fig. A6.1 is not generally valid. Section 3.5 also clearly sets out how to determine the width of EI along with the contributing and interfering portions of the echo signal. However, some of the finer detail related to the EI is not included in § 3.5, which can leave the reader with some unanswered questions. This Annex provides additional background information to help fill in some gaps.

FIGURE A6.1
Weighting function w_i

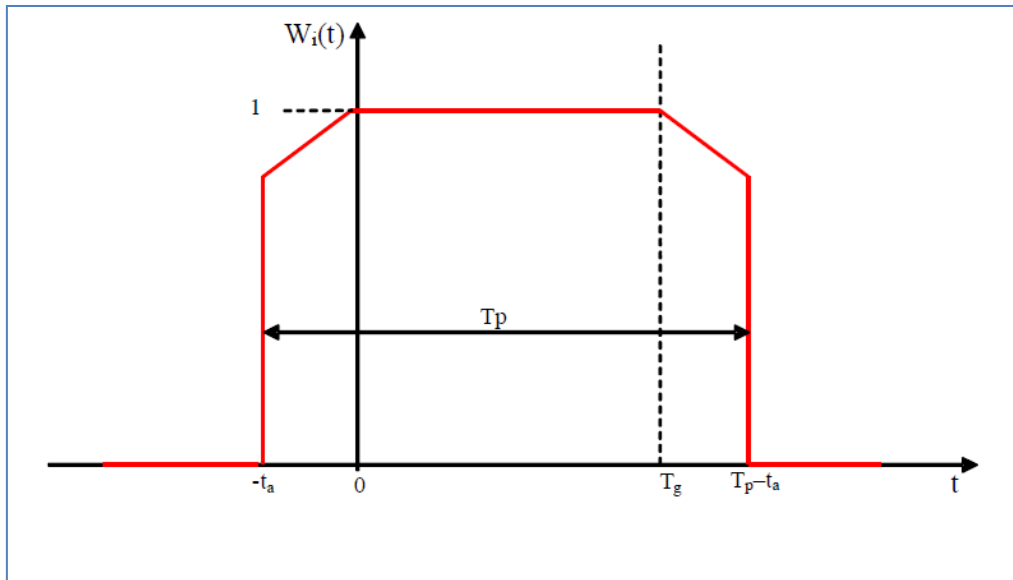

The role of the channel equaliser is to remove, to a practical extent, the distortions that occur in the passband over the transmission channel. To do this, DVB-T/T2 makes use of scattered pilots of known phase and amplitude, and it is usually successful. However, echoes from multipath, and likewise the ‘artificial’ echoes in an SFN, can cause deep periodic ripples in the passband that can occur too frequently for the equaliser to cope with. These ripples, along with their increasingly close spacing with increasingly delayed echoes, cause a rapid degradation in the receiver’s ability to equalise the channel, and therefore decode the signal. Figure A6.2 shows the effect of variously delayed 0 dB echoes on the passband.

FIGURE A6.2
Passband with 0 dB echoes of various delays

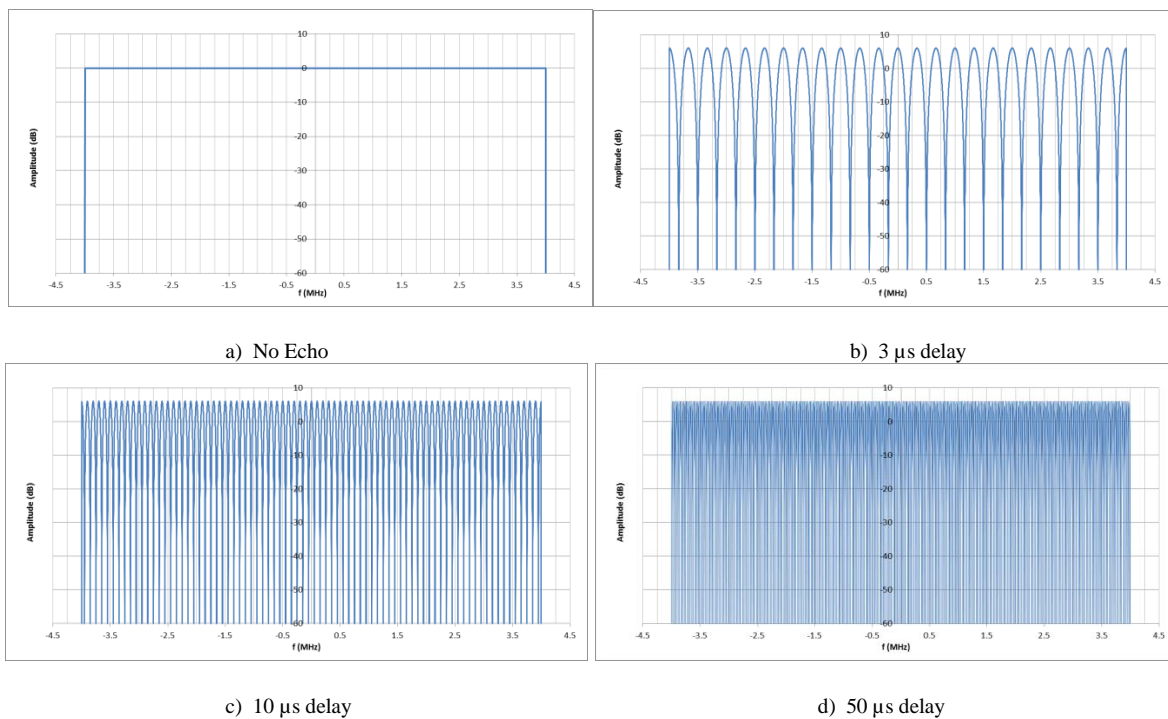

Figure A6.2a shows a typical frequency plot of a normalized DTT signal in a flat 8 MHz wide passband. Figure A6.2b shows the same signal, but this time with the addition of a 0 dB echo delayed by a modest 3 μs . It is clear that the echo introduces a ripple with deep notches. The separation of these notches is 333.3 kHz, or $1/(3 \mu\text{s})$ – that is to say their separation is inversely proportional to the echo delay. Figure A6.2c shows the effect of increasing the delay to 10 μs . The ripples would become more frequent, and would be spaced by 100 kHz. With a 50 μs delay, Figure A6.2d, the ripples are too frequent to be discernible with the resolution of the plot. This relationship between echo delay and ripple separation is confirmed in Attachment to this Annex which includes passband plots of a main signal and a single echo taken by the Radio Communications Agency [RA2000]. At a certain delay, the notch separation increases to the point where it would become comparable to the pilot pattern spacing. It is at this point that the receiver can no longer equalise the channel correctly as the Nyquist criterion of the channel equaliser has been exceeded. An example below illustrates this point.

The parameters relating to “UHF 1” of Table 3.10 form the base for this example, and they are set out below in Table A6.1.

TABLE A6.1

Parameters of “UHF 1” (see Table 3.10)

Mode	UHF 1 (Medium area SFN– Rooftop)
Modulation	256-QAM
FFT size	32k
Code rate	2/3
Pilot Pattern	PP4
Guard interval fraction	1/16
T_g (μs)	224
T_u (μs)	3584
Nyquist limit as fraction of T_u	1/12
Nyquist limit (μs)	299
Equalisation factor	57/64
T_p time (μs)	266

The Nyquist limit of $1/12 T_u$ can be found above (see Table 3.9 in § 3.5 for more detail). Figure K.4 from [EN 302 755 V1.3.1], reproduced below as Figure A6.3 shows how the $1/12$ fraction is derived. In each OFDM symbol, 1 in 24 carriers is a scattered pilot. However, the pilots are staggered between symbols with the first scattered pilot appearing at carrier 24 in the first symbol and 12 in the next, returning to 24 in the following symbol, and so on. In this example both time and frequency interpolation is assumed, which implies that the scattered pilot at carrier 24 from the first symbol is held in memory and used in conjunction with the carrier at position 12 in the next symbol. The effective pilot density then becomes $1/12$, as Table A6.1 shows, rather than $1/24$ (which would be applicable to frequency only Interpolation).

FIGURE A6.3
Scattered pilot pattern PP4 (SISO)

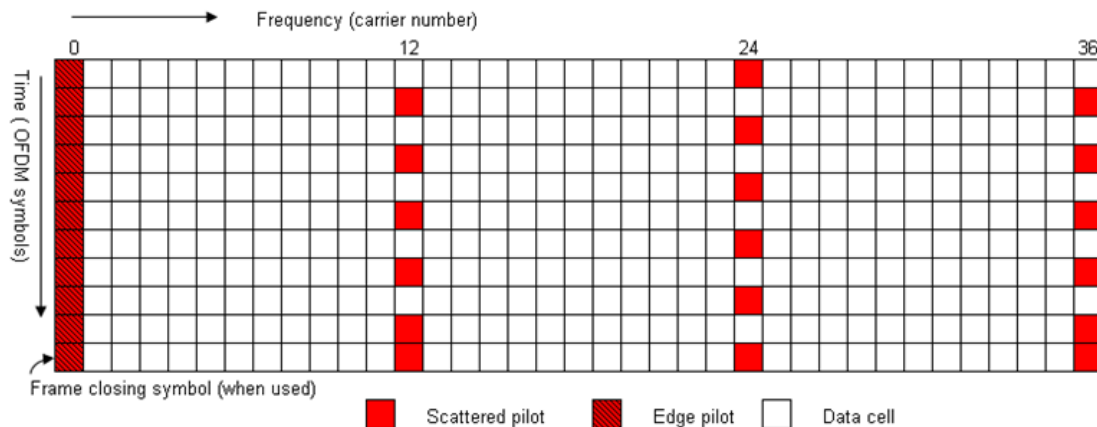

Table 60 of [EN 302 755] shows that the carrier spacing for a DVB-T2 32k mode is 279 Hz. A scattered pilot spacing of 1 in 12 therefore means that pilots occur every 3.348 kHz. At this point, it should be noted that the Nyquist rate of real valued signals (i.e. signals with no imaginary component) is equal to twice the maximum frequency within the signal, which is widely understood. In this case however, the signal effectively being sampled is in the complex domain in which both the amplitude and phase of the signal is known. In such signals the Nyquist limit is equal to the maximum frequency in the sample, rather than twice the maximum frequency. Instead, with complex signals negative frequencies carry different information than positive frequencies, which means that the total bandwidth is the same in both cases. This rather subtle point is fundamental to recognize in this simple explanation.

Figure A6.4 below shows the channel response, carriers and scattered pilots with a 0 dB echo delayed by 300 μ s. Figure A6.5 shows the same signal but plotted with a linear amplitude scale, from which it is clear that the ripple actually consists of a single sinusoid, which must be the maximum frequency in the signal, and therefore equal to the minimum required sample rate. A closer look at the plot reveals that the ripples slightly exceed the frequency of the scattered pilots, and therefore the equaliser's Nyquist limit. A shorter delay would reduce the ripple's frequency so that it would fall within the Nyquist limit. For this mode a Nyquist limit of 299 μ s can be found in Table A6.1, which compares well with this example.

The DVB-T2 implementation guidelines [TS 102 831] indicate that real equalisers cannot perform as well as an ideal one, and a 57/64 equalisation factor is suggested as a means of taking practical considerations into account. This has the effect of reducing the width of EI. T_p , the width of EI, in this case, is calculated to be 266 μ s.

FIGURE A6.4
 DTT passband in a perfect channel with 0 dB echo at 300 μ s delay

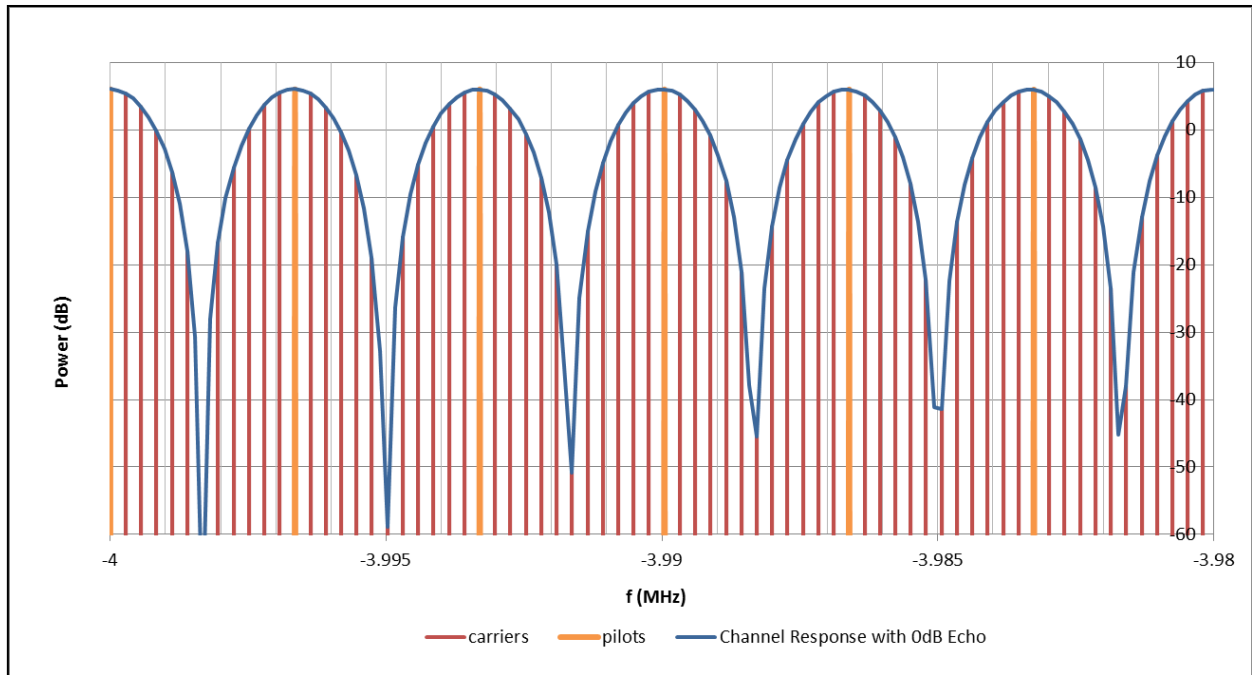
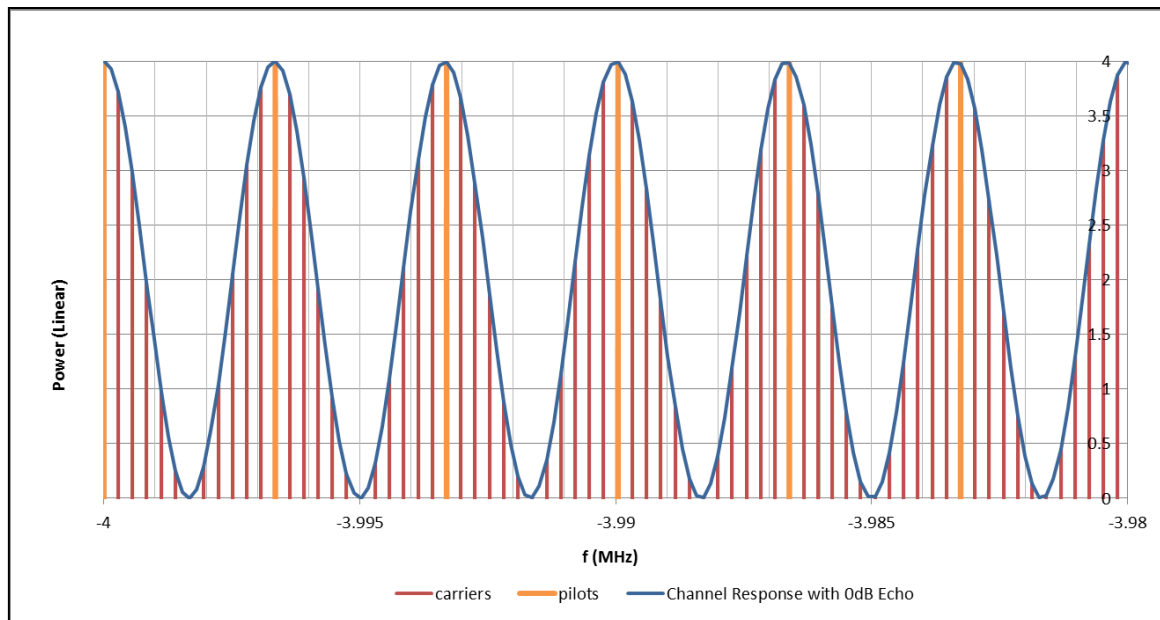

FIGURE A6.5
 DTT passband in a perfect channel with 0 dB echo at 300 μ s delay – linear amplitude



[Po2001] includes a measurement derived echo tolerance characteristic of a practical DVB-T receiver. The main figure from that document (Fig. 1) has been reproduced below as Fig. A6.6. Although the measurements were taken of a DVB-T receiver in 2001, the general findings are valid for this discussion while noting that they are appropriate to a symbol duration of 231 μ s, a guard interval of 7 μ s and a scattered pilot pattern where one in three carriers are pilots. The document makes the following remarks: “Figure 1 shows a typical characteristic, where the plot represents the maximum tolerable echo versus delay. The sharp fall beyond 60 μ s is a function of the channel equalizer. Since only one COFDM carrier in three provides the equalizer with useful information,

the maximum equalizable delay is a third of the active symbol period. If the signal cannot be equalized, the entire echo power appears as noise.”

FIGURE A6.6
A typical echo tolerance characteristic

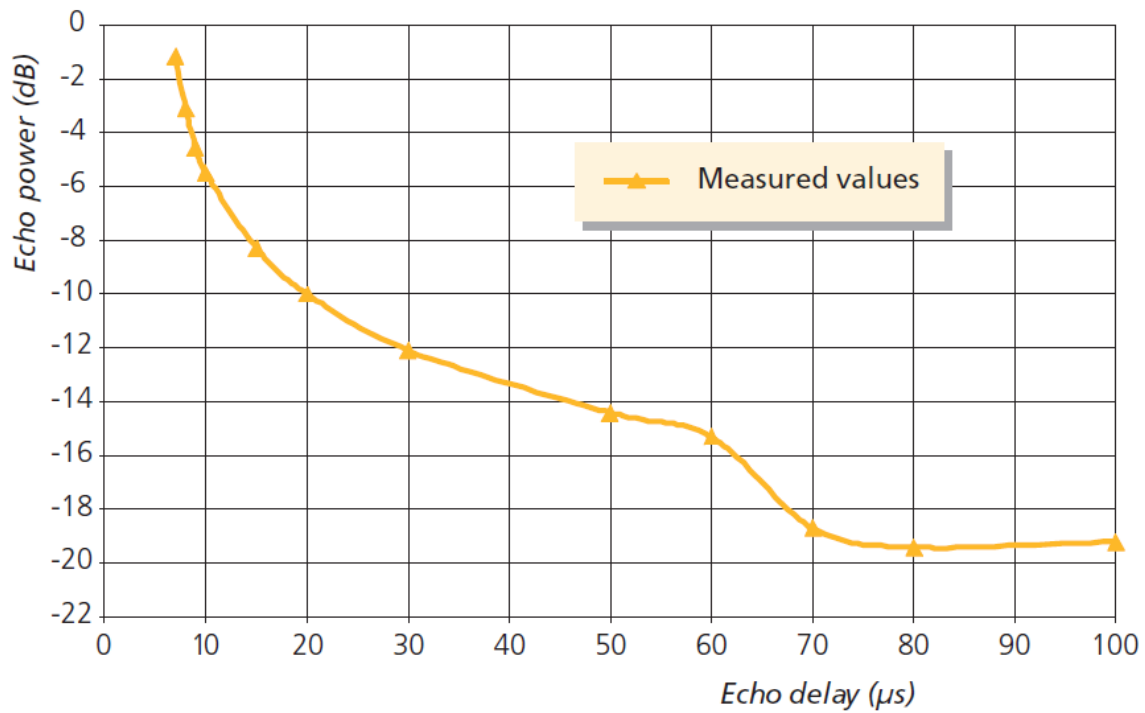

Attachment to Annex 6

Spectrum plots of a main DVB-T signal and a single echo

(Figures from [RA2000])

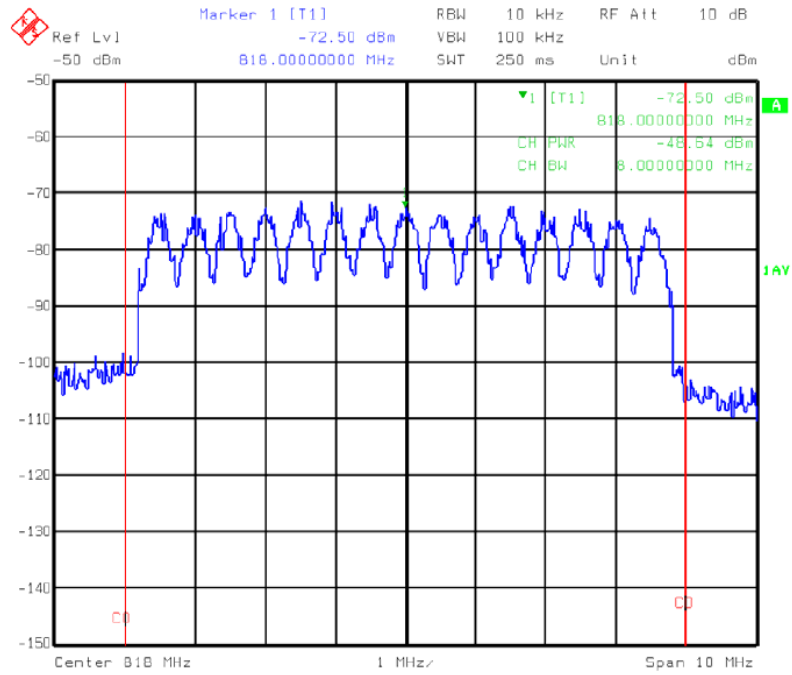

Title: DVB-T signal + single echo (delay = 2us, atten = 5dB)
 Date: 10.MAY.99 10:30:58

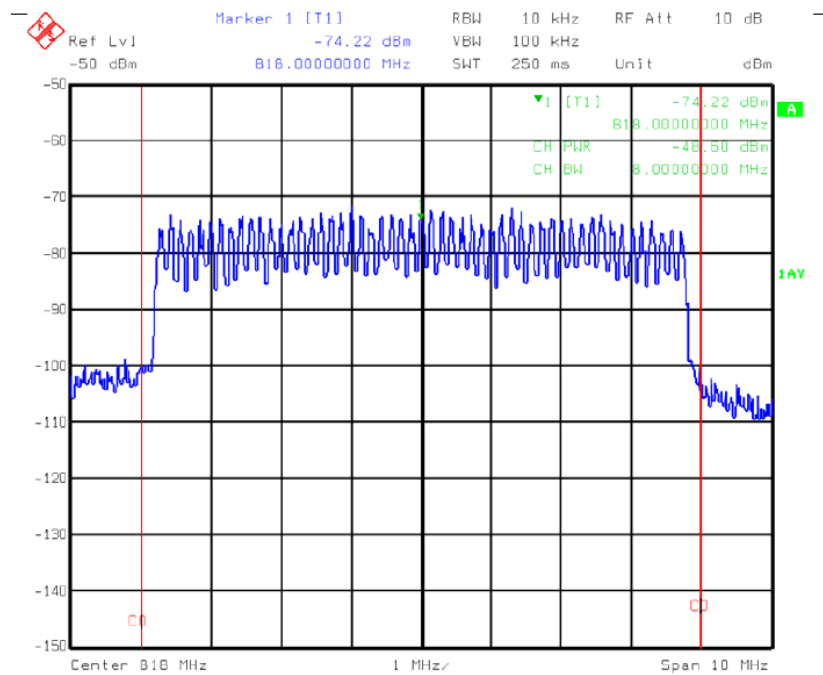

Title: DVB-T signal + single echo (delay = 7us, atten = 5dB)
 Date: 10.MAY.99 10:27:28

Annex 7

Specific implementation scenarios/Country situation

This Annex gives an overview of the current status (October 2013) of DVB-T2 implementation in selected countries in Europe.

A7.1 DVB-T2 in the UK (October 2013)

The UK committed to adopting DVB-T2 in the spring/summer of 2008, primarily to facilitate the delivery of HD services on Freeview (DTT) by the most efficient means. The aim was to introduce DVB-T2 as soon as possible so that viewers would have the opportunity to migrate directly to DVB-T2 as they prepared for switchover, bypassing the need to upgrade their DVB-T receivers later.

In very broad terms the main objectives were to convert one of the three PSB multiplexes to DVB-T2, while the other two would remain DVB-T, and to ensure that the coverage of the new DVB-T2 multiplex would remain identical to what it would have been had it not been converted.

In 2008, when the 'T2 decision' was made, the specification was not complete, no DVB-T2 transmission equipment was available and there were no receivers. Furthermore, the UK was part-way through a detailed and complex digital switchover (DSO) programme involving some 3,100 transmitters. The DSO programme, scheduled for completion in late 2012, was set out prior to the "T2 decision" and was planned to follow a regional basis as shown in Fig. A7.1.

FIGURE A7.1
UK DSO Regions and timescales

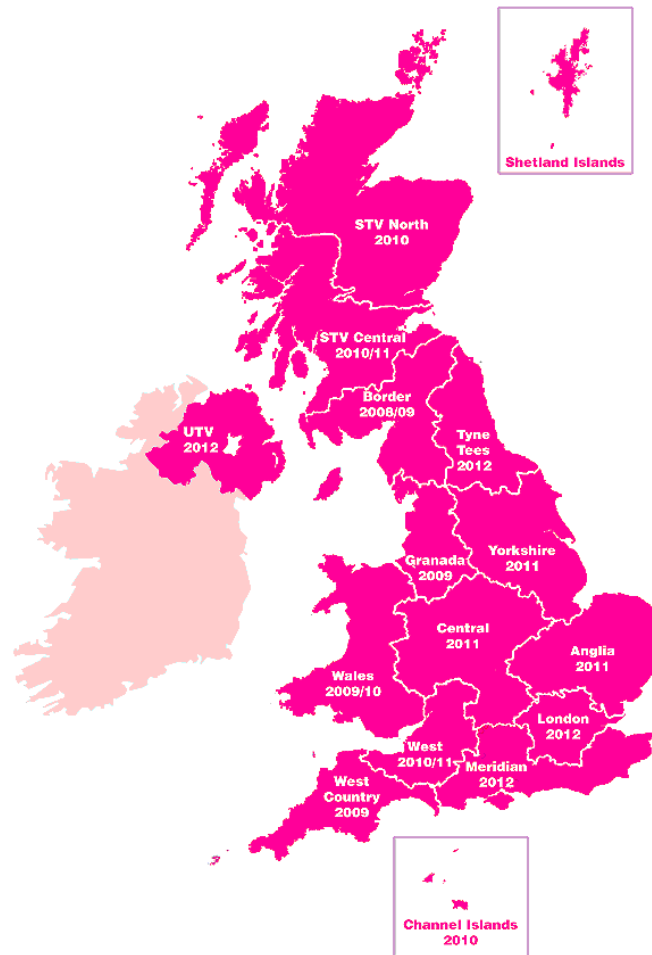

It was deemed critical for the success of DVB-T2 to introduce it as early as possible. This necessitated a relatively aggressive timetable with a launch date planned for December 2009. The following section outlines the main steps in the launch plan and provides some background for the main considerations in the project. It is important to note that a substantial amount of work was required by the many stakeholders in the project including: the regulator, broadcasters, infrastructure providers, equipment manufacturers and content providers.

A7.1.1 UK T2 rollout process

A7.1.1.1 Timeline

The UK DVB-T2 programme broadly followed the high level timeline shown in Fig. A7.2. Each of the major work streams shown is described briefly below.

FIGURE A7.2

High level timeline of UK T2 rollout programme. Red line shows T2 launch date

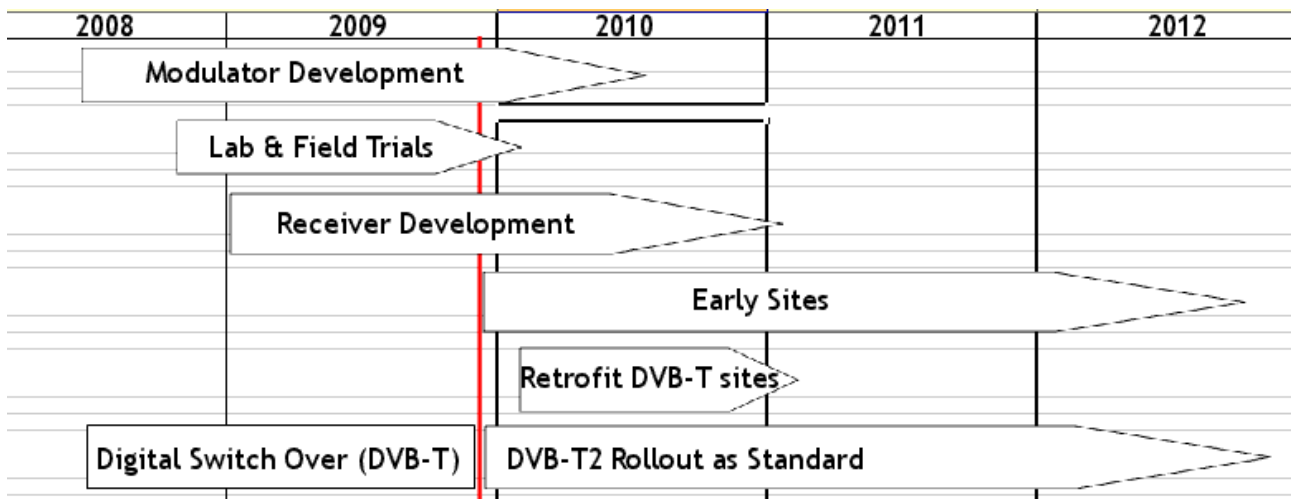

A7.1.1.2 Modulator development

The BBC began the world's first DVB-T2 compliant test transmissions on June 27, 2008 from Guildford. Following this a number of manufacturers developed products which first came to market in 2009, ready for the UK T2 launch.

A7.1.1.3 Lab and field trials

Ofcom, the UK regulator, and the BBC ran field trials in conjunction with manufacturers to fulfil the following aims:

- Test and validate the DVB-T2 standard
- Determine and validate the UK transmission mode
- Aid manufacturers' transmitter and receiver development.

Not all the possible DVB-T2 modes in the specification were tested as explained in the following section.

A7.1.1.4 Determination of transmission mode

Three main factors determined the UK mode for T2:

- Maintenance of the DVB-T based post-DSO PSB coverage requirement of 98.5% of the UK population.
- Reuse of existing broadcast infrastructure for practicality and to reduce implementation costs (a commercial requirement of the T2 specification). This requirement implies the use of the same ERP and antenna patterns as proposed for the DVB-T multiplex that was upgraded.
- Maximum capacity.

The first two points above largely dictate a C/N for the T2 transmission substantially the same as that for the post-DSO DVB-T network.

Potential optimization of the network based on other modes was not considered.

A7.1.1.5 Receivers

The UK stakeholders developed a minimum receiver specification for:

- Set top Boxes
- Integrated Digital TVs

– Digital Television Recorders.

The DTG HD D-Book version 6 (March 2009) initially specified the technical system for use within the UK. Subsequent versions have since been released.

The UK broadcasters worked closely with a number of manufacturers to develop DVB-T2 products for launch in late 2009.

A7.1.1.6 Early sites

It is apparent from Fig. A7.1 that some key population areas would not receive the HD services until late in the DSO programme, with London planned to switch in 2012.

To increase the consumer market for receivers and to aid a successful launch, five “early” T2 services were launched in the following key cities covering approximately seven million households.

London

Glasgow and Edinburgh

Leeds/York

Birmingham

Newcastle, Sunderland, Middlesbrough.

Furthermore, the following significant sporting events occur before HD services would be available in some of the above regions if no ‘early’ sites were introduced. Providing large cities with HD for these events is likely to increase T2 uptake.

Football World Cup (June/July 2010)

Rugby World Cup (September/October 2011)

London Olympics (July 2012)

A7.1.1.7 Integration of T2 into the DSO programme and retrofit

The T2 launch began part-way through the pre-determined DVB-T rollout, meaning that some areas in the UK were entirely switched over to DVB-T by the time DVB-T2 was first launched, while others had a mixture of the pre-switchover analogue and low power DVB-T networks.

Beginning with the Granada region in late 2009, DVB-T2 was incorporated into the DSO programme and one PSB multiplex has since been ‘rolled out’ with T2 as standard. Managing to do this at such an early stage in the DSO programme significantly simplified the consumer message and rapidly began growing the consumer market.

It was also necessary to undertake a retro-fit programme to upgrade to T2 the areas of the UK such as the West Country that had already switched over and were operating as DVB-T only. This process was completed with minimal change and disruption to the DVB-T network as it primarily involved replacing the existing DVB-T modulator to the newer DVB-T2 version.

To achieve these goals in a short time-frame, a substantial amount of work has been undertaken by the many stakeholders in the project including the regulator, broadcasters, infrastructure providers and equipment manufacturers.

A7.1.1.8 Re-transmitters and transposers

The regenerative relays in the DVB-T network require replacement or upgrade to make them suitable for DVB-T2. A substantial portion of the DVB-T transposer network has continued to operate correctly with a DVB-T2 signal without modification, although some changes will be necessary to maintain the monitoring/alarm systems.

A7.1.1.9 SFNs

The UK network makes use of medium power SFNs in a small number of cases. One T2 Gateway is needed for each SFN to create the Management Interface (T2-MI) stream that enables the SFNs to work correctly. These devices were not required for DVB-T. The primary SFNs have been implemented and are operational. They have been found to operate as expected.

A7.2 DVB-T2 in Finland (October 2013)

In VHF there are three national multiplexes dedicated to DVB-T2 broadcasting and all the network licences were granted to the network operator DNA. In October 2013 three DVB-T2 multiplexes cover over 80% of the population. DNA has built the networks mainly on telecom sites with lower power transmitters. DNA operates three DVB-T2 multiplexes with network parameters: 32k, 256-QAM, CR 4/5, GI 19/256.

In UHF Digita operates four national DVB-T multiplexes: two covering about 100%, one covering about 95% and one covering about 90% of the population. In UHF DVB-H transmissions were closed down in March 2012 and Digita was allowed to convert the DVB-H network to a DVB-T2 network. In October 2013 the national DVB-T2 multiplex covers about 85% of the population. This DVB-T2 multiplex is operated by Digita with network parameters: 8k ext., 64-QAM, CR 4/5, GI 1/8. Furthermore Digita has another network licence of the DVB-T2 multiplex and the coverage of the network will be about 60% of the population by the end of 2013. Digita operates this DVB-T2 multiplex with network parameters: 32k ext., 256-QAM, CR 4/5, GI 1/32. All the DVB-T/T2 networks of Digita are based on main stations with tall masts and high power transmitters in addition to low power filling stations.

In UHF two DVB-T2 multiplexes (one national and one regional) are not used for the time being. All the DVB-T/T2 network licences (except one) are valid until 2017 and at this moment the frequency planning of new DVB-T/T2 networks (since 2017) is going on to take account of the loss of the 700 MHz band.

A7.3 Introduction of DVB-T2 in Sweden

A7.3.1 Rollout of two DVB-T2 multiplexes in Sweden, 2010-2012

HDTV was launched in the terrestrial network in Sweden on 1st November 2010. Nine HDTV programmes were licenced, offering a mixture of existing programmes (simulcast SD & HD) and new programmes (HD exclusively). The public service broadcaster “Sveriges Television” has been awarded a licence for two of its programmes (simulcast with SD).

One of the nine licences was returned and in February 2012 the Swedish Broadcasting Authority received 26 new applications for the licence. Licences for SDTV programme services were awarded.

The programmes are transmitted in two multiplexes, Multiplex 6 and 7, both using DVB-T2 MPEG-4. Multiplex 6 uses UHF frequencies only and will carry five HDTV programmes, while Multiplex 7 uses both UHF and VHF frequencies. For the UHF transmissions, the extended bandwidth mode is used. For VHF this feature is not possible without exceeding the spectrum mask. Therefore the normal bandwidth mode is used for the VHF transmissions. The seventh multiplex carries three HDTV programmes and five SDTV programmes. The reason for using frequencies in the VHF band is the loss of the seventh UHF layer in certain areas as a consequence of the decision by the Government to use the frequency band 790-862 MHz for mobile services.

For Multiplex 7 about half of the transmitters will use VHF frequencies and the other half UHF frequencies. This is also reflecting the population coverage, where approximately half of the population will be reached by the VHF transmissions and the other half by the UHF transmissions. It is very important to inform the viewers about the fact that they might need a new VHF antenna to

receive all the new services, especially in areas where frequencies in VHF Band III were not used for the analogue TV network.

In the network planning for the VHF transmissions a slightly lower antenna gain has been assumed, compared to what is common in previous planning documents for terrestrial television and in the GE06 Agreement, taking into account that the viewers might not be very keen on buying new big VHF antennas. The higher man-made noise level in VHF is also taken into account using a planning margin.

The large number of VHF transmitters has results in some delays due to the large amount of new transmitting antenna installations.

On the launch 1st of November 2010 the two DVB-T2 multiplexes covered 70% population and just a few months later it covered 80% of the population.

The DVB-T2 rollout was completed with nationwide coverage (approx. 98% of the population) before the Olympic Games in London 2012.

In February 2012 the 6th multiplex (DVB-T2) was regionalized. SVT1 HD and SVT2 HD are now regionalized into 18 regions and TV4 HD into 28 regions.

A7.3.2 Migration of DVB-T to DVB-T2

Prior to the upcoming license period which starts in 2014, the Swedish broadcasting authority has developed a strategy that describes our starting points and focus of our work with terrestrial television in all matters not directly governed by the Swedish Broadcasting Act.

The strategy is primarily valid until 31 March 2020 and one of the main points is:

- The Authority will promote a gradual transition to DVB-T2 during the licensing period 2014-2020. At least, three multiplexes shall use DVB-T2 by the end of 2014 and the other multiplexes are to migrate gradually during the license period.

The aim from the broadcast operator is to migrate two multiplexes during 2014.

A7.3.3 Current operational modes

The parameters used for multiplex 6 and 7 are as follows:

DVB-T2 modes	Mux 6	Mux 7	Mux 7
Mode alias/reference	U22	V21	U21
Spectrum	UHF IV-V	VHF III	UHF IV-V
Bandwidth	8 MHz	7 MHz	8 MHz
T2 version	v1.1.1	v1.1.1	v1.1.1
L1 modulation	64QAM	64QAM	64QAM
T2 frame preamble format	SISO	SISO	SISO
Extended carrier mode	Yes	No	Yes
FFT size	32k	32k	32k
Guard Interval	1/16	19/256	19/256
PAPR reduction	TR-PAPR	TR-PAPR	TR-PAPR
Pilot Pattern	PP4	PP4	PP4
Num T2 Frames	2	2	2
L_f	62	42	20

DVB-T2 modes	Mux 6	Mux 7	Mux 7
Mode alias/reference	U22	V21	U21
Payload type	TS	TS	TS
PLP Mode	High Efficiency	High Efficiency	High Efficiency
Single/Multiple PLP	Single	Single	Single
PLP modulation	256QAM	256QAM	256QAM
Rotated constellation	Yes	Yes	Yes
FEC type	64k LDPC	64k LDPC	64k LDPC
Code Rate	2/3	2/3	3/5
Time interleaving type	0	0	0
Time interleaving length	3	3	3
ISSY	Disabled	Disabled	Disabled
Null packet deletion	No	No	No
<i>Efficient bit rate/capacity</i>	<i>36.55</i>	<i>30.81</i>	<i>31.67</i>
<i>Guard Interval (time)</i>	<i>224 μs</i>	<i>304 μs</i>	<i>266 μs</i>
<i>T2-Frame duration (ms)</i>	<i>236.32</i>	<i>185.056</i>	<i>77.224</i>
<i>T2 Superframe duration (ms)</i>	<i>472.64</i>	<i>370.112</i>	<i>154.448</i>

Multiplex 6 with the bit rate 36.55 Mbit/s is carrying five HD-programmes and multiplex 7 with approx. 31 Mbit/s is carrying three HD-programmes and five SD-programmes.

A7.4 DVB-T2 in Denmark (October 2013)

In Denmark six nationwide DTT multiplexes are in operation, four DVB-T and two DVB-T2.

Two DVB-T multiplexes are used for free-to-air public services while two DVB-T and the two DVB-T2 multiplexes are used for pay-services.

All multiplexes use MPEG4/AVC, and both SDTV and HDTV programmes are available as free-to-air and pay services, i.e. it is not necessary to have a DVB-T2 receiver in order to receive free-to-air HDTV services.

There are no plans at present to convert the two public service multiplexes to DVB-T2.

The first DVB-T2 multiplex was launched in 2012 with a conversion of an DVB-T multiplex while a second DVB-T2 multiplex was launched in September 2013 on a set of frequencies previously reserved for mobile TV.

The two DVB-T2 multiplexes use the following parameters:

Bit rate (Mbit/s)	36.55
Channel bandwidth (MHz)	8
Signal bandwidth	“Extended”
FFT size	32k
Modulation	256-QAM
Code rate	2/3
Pilot pattern	PP4
Guard interval fraction	1/16
Guard interval (μ s)	224

A7.5 DVB-T2 in Austria (October 2013)

A7.5.1 Situation in Austria after ASO (Analogue Switch Off)

- In 2000, 14% of the Austrian households regularly watched two programmes over analogue terrestrial television (450 transmitter sites).
- After the ASO, the percentage of terrestrial TV (DTT) dropped down to 6%; 3 programmes (1 multiplex) are distributed by 320 transmitters to reach 96% of population; 8 programmes (2 multiplexes) can be viewed by 90% of the population.

A7.5.2 Increasing the market share of digital terrestrial television

To reach this goal, the following was regarded as necessary:

- More channels by using three additional multiplexes in urban areas (up to 40 programmes). All programmes with a market share > 0.8% were chosen.
- Introducing DVB-T2 to offer HD content.
- Competitive with cable and satellite services:
Using the opportunity of the cable A/D switch with a lower price
Higher flexibility than satellite TV (2nd and 3rd television sets).
- Indoor coverage in urban areas to offer straightforward installation.
- Termination of contract at any time.
- Mixture of free-to-air, free-to-air with registration, and pay-TV offers. The current offer is shown below:



A7.5.3 DVB-T2 network

- At least one additional transmitter was built in urban areas for indoor reception for 34% population.
- All main transmitters are equipped with DVB-T2 to provide rooftop reception for 90% population.
- The area around Vienna is crucial, 25% of all Austrian people live there. Nearly 100% of the population in Vienna can receive DVB-T2 with indoor antennas.

A7.5.4 DVB-T2 parameters

The parameters were optimized for fixed reception with maximum data rate while using the same network topology as DVB-T; the guard interval has the same value as ORS's DVB-T system variant B3H.

- Bandwidth: 8 MHz
- Modulation: 64-QAM
- FFT mode: 32k
- Code rate: 3/4
- Guard interval: 1/16 (= 224 μ s)
- Rotated mode: yes
- Extended mode: yes
- Compression: MPEG-4
- Data rate: 30.31 Mbit/s

A7.5.5 Changes in the DVB-T network

ORS extended the DVB-T network to offer the same reception quality for all multiplexes (A, B, D, E, F) in the urban areas to ensure that every DVB-T2 customer can receive these multiplexes. After the (final) T/T2 switchover these can be used to add SD content or to broadcast all existing content in HD (all HD future). Currently MUX A carries ORF1 and ORF2 in standard definition (SD) and MUX D carries ORF1 and ORF2 in high definition (HD).

In this way, the public broadcaster started the simulcast phase for 90% population coverage.

A7.6 Introduction of DVB-T2 with HEVC in Oman

A7.6.1 Introduction

The Public Authority for Radio and TV (PART) in the Sultanate of Oman started the installation of the first phase of DVB-T2 TV Transmitters in 69 sites. The new project will cover the main cities, and the existing analogue TV Transmitters will be replaced by the new DVB-T2 transmitters. PART started three pilot transmissions using DVB-T2 multiplex with MPEG4 in Muscat, Barka in Batina region, and Salalah in Dhofar region. The pilot transmission was successful, as it gives PART the main characters of DVB-T2 and guidelines for the new projects.

Recently, some countries started to implement DVB-T2 multiplex together with High Efficiency Video Coding (HEVC) in their new projects. DVB-T2 with HEVC is capable of providing a satisfactory number of HD and UHD programmes. Due to the shortage of frequencies spectrum and the need of high bit rate in today's applications, PART started revising the actual situation and decided to move forward and implement DVB-T2 with HEVC in the project.

A7.6.2 Project implementation

The typical parameters used for the network planning is specified in Table A7.1. The project has been designed for indoor reception (mobile reception). The programs will be mainly HD.

TABLE A7.1

Parameters used for the network planning

Network	MFN
Channel Bandwidth	8 MHz
Carrier Mode	32 K extended
Carrier Modulation	64 QAM
Pilot Pattern	PP4
Guard Interval	1/32
FEC	3/4

According to the project's plane, the first station suppose to be on air by the first quarter of year 2018. Figure A7.3 shows the coverage areas in the north part of the Sultanate. The majority of the population are scattered in the north part of the Sultanate. The second phase of the project will cover the areas which are not covered by the first phase.

FIGURE A7.4
Coverage of Ruwi Hill Station in Muscat

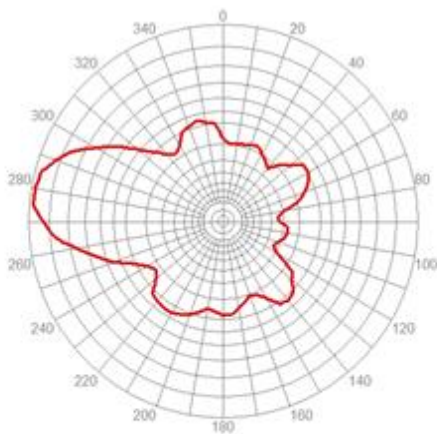
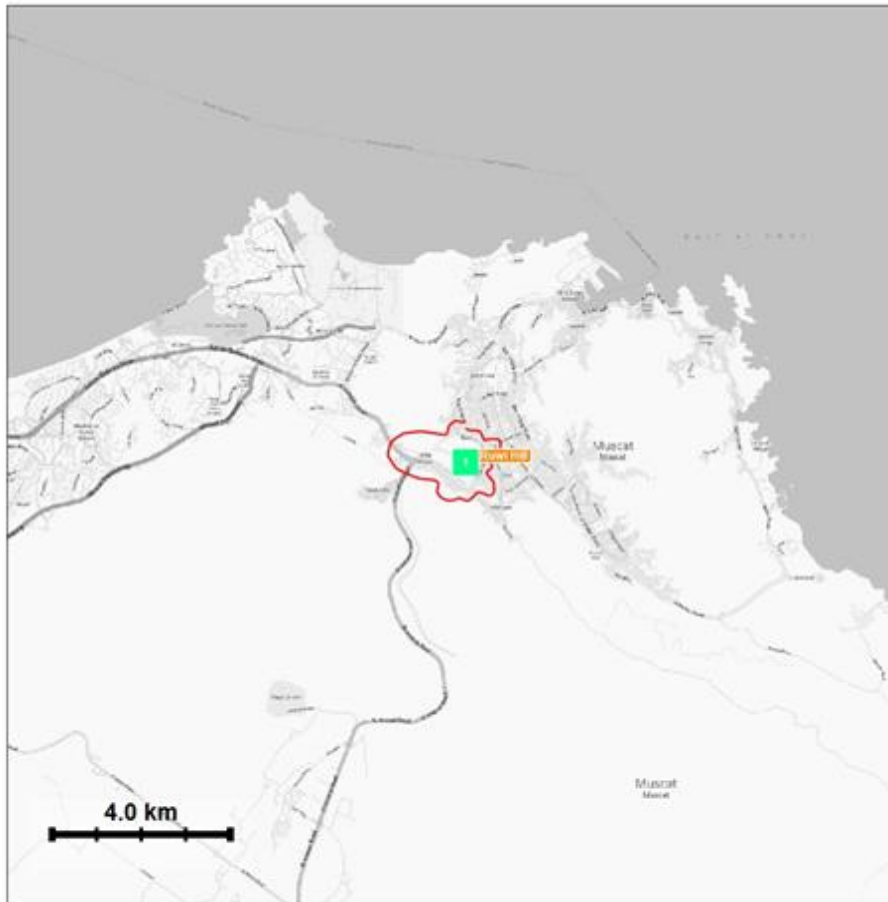

Callsign	1
EW	58.32072 (4DMS)
NS	23.35322 (4DMS)
Altitude ASL	188.0 m
Address	Ruwi Hill
Info2	Existing Site
User	PART - OMAN
Date	19122013
Channel	31
Signal	DVB-T2 8MHz

ATDI / PART - OMAN

Table A7.2 shows the 69 stations with their allocated frequencies and ERP power.

TABLE A7.2
DVB-T2 site names, frequencies, and ERP

No.	Site name	Channel number	ERP (W)	Freq. (MHz)
1	Adam	36	5000	594
2	Al Abyad	23	500	490
3	Al Amerat	33	10000	570
4	Al Awabi	22	500	482
5	Al Haylayn	26	500	514
6	Al Hujayrimat	21	1000	474
7	Al Hyal	25	500	506
8	Al Lansab	36	500	594
9	Al Rustaq	29	2000	538
10	Al Wasit	28	500	530
11	B.B Ali	22	20000	482
12	Bahla	24	10000	498
13	Bid Bid	22	1000	482
14	Bukha	31	500	554
15	Bulaida	28	500	530
16	Buraymi	34	50000	578
17	Dhank	32	5000	562
18	Fanjah	36	500	594
19	Haima	23	5000	490
20	Heel	32	500	562
21	Ibra	24	20000	498
22	Ibri	32	20000	562
23	Jabal Al Harah	23	5000	570
24	Jabal Hawrah	30	500	546
25	Khasab	35	500	586
26	Madhah	30	500	546
27	Masira Island	36	5000	594
28	Mazara	24	500	498
29	Quram	30	500	546
30	Muhut	26	5000	514
31	Nizwa	23	10000	490
32	Qantab	35	5000	586
33	Quriyat	22	5000	482
34	Ras Madraka	28	500	530
35	Riyam	36	500	594

TABLE A7.2 (end)

No.	Site name	Channel number	ERP (W)	Freq. (MHz)
36	Ruwi Hill	25	50000	506
37	Saham	31	50000	554
38	Saiq	28	20000	530
39	Samad	21	1000	474
40	Shinas	36	20000	594
41	Suqrah	21	500	474
42	Sur	31	10000	554
43	Tanuf	25	500	506
44	Taw	30	500	546
45	Tibat	23	500	490
46	Toyan	27	500	522
47	Yiti	30	500	546
48	Falaj Al sham	29	2000	538
49	Sini 1 oman tel	32	500	562
50	Siya	26	2000	514
51	Yanqul	23	5000	490
52	Al Mazionah	28	2000	530
53	Al Mughsayl	35	500	586
54	Dahariz	29	20000	538
55	Dimeet	34	2000	578
56	Jilub	33	1000	570
57	Marmul	23	500	490
58	Mudhi	24	5000	498
59	Mugshan	26	1000	514
60	Sadah	31	1000	554
61	Sarfait	26	20000	514
62	Sharbithat	29	500	538
63	Thumrait	26	20000	514
64	Hasik	23	500	490
65	Jabal alqamar	23	20000	490
66	Mirbat (Jabal Samhan)	21	10000	474
67	Shelim (New)	28	10000	530
68	Shuwaymiya. Radio.	29	500	538
69	Barka	21	50000	474