

International Telecommunication Union

ITU-R
Radiocommunication Sector of ITU

Report ITU-R BT.2215-1
(10/2011)

**Measurements of protection ratios and
overload thresholds for broadcast
TV receivers**

BT Series
Broadcasting service
(television)



International
Telecommunication
Union

Foreword

The role of the Radiocommunication Sector is to ensure the rational, equitable, efficient and economical use of the radio-frequency spectrum by all radiocommunication services, including satellite services, and carry out studies without limit of frequency range on the basis of which Recommendations are adopted.

The regulatory and policy functions of the Radiocommunication Sector are performed by World and Regional Radiocommunication Conferences and Radiocommunication Assemblies supported by Study Groups.

Policy on Intellectual Property Right (IPR)

ITU-R policy on IPR is described in the Common Patent Policy for ITU-T/ITU-R/ISO/IEC referenced in Annex 1 of Resolution ITU-R 1. Forms to be used for the submission of patent statements and licensing declarations by patent holders are available from <http://www.itu.int/ITU-R/go/patents/en> where the Guidelines for Implementation of the Common Patent Policy for ITU-T/ITU-R/ISO/IEC and the ITU-R patent information database can also be found.

Series of ITU-R Reports

(Also available online at <http://www.itu.int/publ/R-REP/en>)

Series	Title
BO	Satellite delivery
BR	Recording for production, archival and play-out; film for television
BS	Broadcasting service (sound)
BT	Broadcasting service (television)
F	Fixed service
M	Mobile, radiodetermination, amateur and related satellite services
P	Radiowave propagation
RA	Radio astronomy
RS	Remote sensing systems
S	Fixed-satellite service
SA	Space applications and meteorology
SF	Frequency sharing and coordination between fixed-satellite and fixed service systems
SM	Spectrum management

Note: This ITU-R Report was approved in English by the Study Group under the procedure detailed in Resolution ITU-R 1.

Electronic Publication
Geneva, 2012

© ITU 2012

All rights reserved. No part of this publication may be reproduced, by any means whatsoever, without written permission of ITU.

REPORT ITU-R BT.2215-1

**Measurements of protection ratios and overload thresholds
for broadcast TV receivers**

(5/2011-10/2011)

TABLE OF CONTENTS

	<i>Page</i>
1 Executive summary	3
2 Abbreviations	3
3 Useful definitions	3
3.1 Radio frequency signal-to-interference ratio (<i>C/I</i>)	3
3.2 Radio frequency protection ratio (PR).....	3
3.3 Receiver (front-end) overloading threshold.....	4
3.4 Adjacent channel leakage power ratio	4
3.5 “Can” tuners.....	4
3.6 “Silicon” tuners.....	4
4 References	4
4.1 Broadcasting technology characteristics.....	4
4.2 Mobile technology characteristics	5
5 Measurement methodology	5
5.1 Example test set-up.....	5
5.2 Wanted signal levels	7
5.3 Frequency offsets between interfering signal and wanted signal	7
5.4 Measurements in the presence of a time varying interfering signal	8
5.5 UMTS uplink	8
5.6 LTE – downlink.....	8
5.7 LTE – uplink.....	8
5.8 Interferer reference power level.....	8
5.9 Characterization of the interfering signal	8
5.10 Failure point assessment methods	9
5.11 Method for determining protection ratios and overloading thresholds.....	9

	<i>Page</i>
6 Conclusions and further work required	15
Annex 1 – DVB-T receiver performance in the presence of interfering signals from DVB-T, UMTS and LTE.....	15

1 Executive summary

This Report documents measurements of protection ratio (PR) and overloading threshold (O_{th}) against interference from other broadcasts or mobile broadband services in the 800 MHz band.

The types of interference used in the tests and the actual tests themselves varies with the different broadcasting system and mobile technologies used around the world.

The aim of the Report is to establish test procedures together with measurement results to assist in network planning and sharing studies for the co-existence of TV broadcasting, with either mobile services, or other services and applications.

The original test details and measurement data, together with information on which particular Recommendation and its version number was updated with this data are contained in the individual annexes.

2 Abbreviations

BS	Base station
O_{th}	Overloading threshold
PR	Protection ratio
TPC	Transmit power control
UE	User equipment – the mobile handset
RB	Resource block – a unit of data transmission in LTE, represented by a certain number of carriers in a uplink or downlink symbol in the frequency domain.
FDMA	Orthogonal frequency-division multiplex access – a multi-carrier modulation system used for the LTE downlink.
SC-FDMA	Single carrier frequency division multiplex access – a multi-carrier modulation system used for the LTE uplink.

3 Useful definitions

3.1 Radio frequency signal-to-interference ratio (C/I)

It is the ratio, generally expressed in dB, of the power of the wanted signal to the total power of interfering signals and noise, evaluated at the receiver input (see Recommendation ITU-R V.573).

The power of the wanted signal is measured in a bandwidth equal to the wanted signal bandwidth, while the total power of interfering signal and noise is measured in a bandwidth equal to the interfering signal bandwidth.

3.2 Radio frequency protection ratio (PR)

It is the minimum value of the signal-to-interference ratio required to obtain a specified reception quality under specified conditions at the receiver input (note that this differs from the definition in Recommendation ITU-R V.573). In this Report, the “specified reception quality” and the “specified conditions” have been defined separately by each entity that has undertaken measurements.

Usually, PR is specified as a function of the frequency offset between the wanted and interfering signals over a wide frequency range. In this Report, PR specified in this way is referred to as “PR curve”. PR curves show the ability of a receiver to discriminate against interfering signals on frequencies differing from that of the wanted signal.

3.3 Receiver (front-end) overloading threshold

Overloading threshold (O_{th}) is the interfering signal level expressed in dBm, above which the receiver begins to lose its ability to discriminate against interfering signals at frequencies differing from that of the wanted signal (i.e., the onset of strong non-linear behaviour). Therefore, above the overloading threshold the receiver will behave in a non-linear way, but does not necessarily fail immediately depending on the receiver and interference characteristics.

3.4 Adjacent channel leakage power ratio

Adjacent channel leakage power ratio (ACLR) is the ratio of the filtered mean power centred on the assigned channel frequency to the filtered mean power centred on an adjacent channel frequency.

The requirements shall apply whatever the type of transmitter considered (single carrier or multi-carrier). It applies for all transmission modes foreseen by the manufacturer's specification. For a multi-carrier base station (BS), the requirement applies for the adjacent channel frequencies below the lowest carrier frequency transmitted by the BS and above the highest carrier frequency transmitted by the BS for each supported multi-carrier transmission configuration. The requirement applies during the transmitter ON period.

3.5 “Can” tuners

“Can” tuners are classical superheterodyne tuners housed in a metal enclosure containing discrete components. Classically, there are fixed and tunable circuits made up from discrete inductors and transistors usually with varactor diode frequency control. The metal enclosure should minimize RF interference and eliminate crosstalk and stray radiation.

3.6 “Silicon” tuners

“Silicon” tuners are IC-based tuners integrating all tuner circuitry into a small package directly to be fitted onto main boards. The tuned circuits may be completely absent or can be integrated onto the silicon. The silicon chip may be protected from external electromagnetic interference by a metallic cover. Silicon tuners have different characteristics to can tuners and their performance can be better and worse at some frequency offsets compared to can tuners. This technology is still developing.

4 References

4.1 Broadcasting technology characteristics

The following references explain the characteristics of the different broadcast systems including transmitter spectrum masks.

- DVB-T system characteristics: Recommendation ITU-R BT.1306, ETSI EN 300 744
- DVB-T2 system characteristics: Recommendation ITU-R BT.1877, ETSI EN 302 755
- ISDB-T system characteristics: Recommendation ITU-R BT.1306, ARIB STD-B31
- ATSC system characteristics: Recommendation ITU-R BT.1306, ATSC A/53
- DTMB system characteristics: Recommendation ITU-R BT.1306, GB20600-2006.

4.2 Mobile technology characteristics

The following references explain the characteristics of the different mobile broadband systems.

- UMTS system characteristics: ETSI TS 125.101, ETSI TS.125.104
- LTE system characteristics: ETSI TS 136.101, ETSI TS.136.104.

5 Measurement methodology

5.1 Example test set-up

An example basic test setup for protection ratio and overloading threshold measurements is depicted in Fig. 1.

FIGURE 1

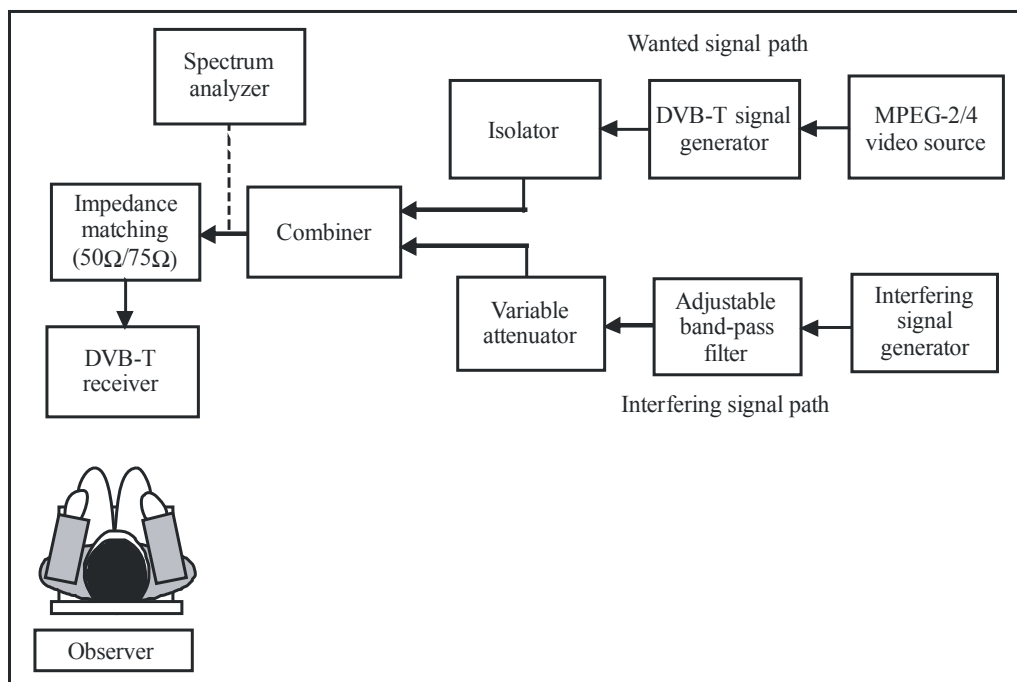

It is necessary to insert an adjustable band-pass filter between the interfering signal generator and the combiner. The objective of this filter is to eliminate the noise generated by the interfering signal generator and adjust the interfering signal to the correct interference transmission mask and ACLR values. In fact, most of the RF signal generators have a wide frequency range (from several hundred of kHz to several GHz) prohibiting the use of an internal adjustable RF channel filter over their whole frequency range. Consequently, depending on the generated signal level, a non-negligible wideband noise may be observed at the generator output. The higher the generated interfering signal level, the higher the noise level. The reduction of the undesired wideband noise by filtering at the output of interfering signal generator is shown in Fig. 2. If this noise is not reduced by filtering, it is impossible to measure the actual protection ratios of the receiver under test. This is due to the wideband noise generated by the interfering signal generator, falling into the wanted signal channel, which cannot be reduced by the receiver filter. In this particular case, the receiver loses its ability to discriminate against interfering signals on frequencies differing from that it is tuned to. This phenomenon is shown in Fig. 3. It is also advisable to insert an isolator between the combiner and the DVB-T signal generator to keep the power from the interfering signal generator returning to the DVB-T signal generator output.

FIGURE 2

The benefit of band-pass filtering at the interfering signal generator output

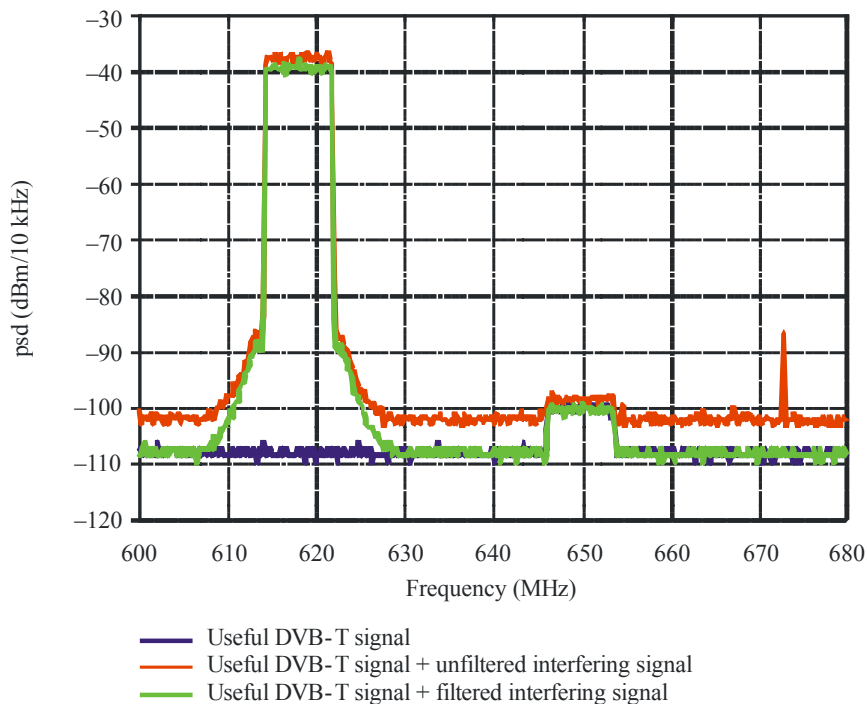
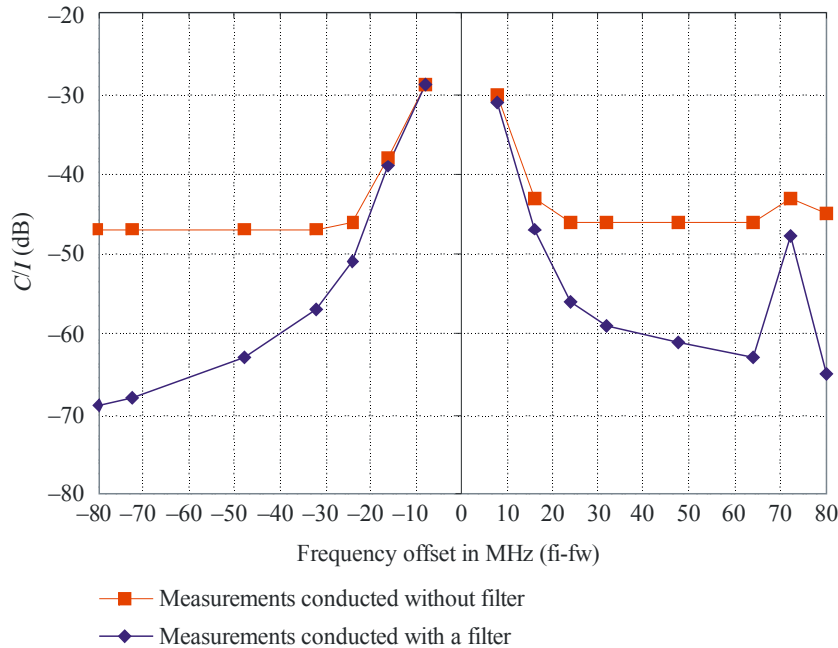

FIGURE 3

The benefit of band-pass filtering at the output of the interfering signal generator
(wanted signal level = Rx sensitivity +10 dB)



Report BT.2215-03

5.2 Wanted signal levels

Protection ratios and overloading thresholds of a receiver are derived from its C(I) curves (see § 5.11). The measurements should be carried out by using different wanted signal levels to cover the range from weakest to strongest signals. The following wanted signal levels are advised as a possible range: receiver sensitivity +5, +10, +20, +30, +40, +50, +60, +70 and +80 dB. This range could be extended if the overloading threshold of the receiver is not reached. At low wanted signal levels the protection ratio limit is usually reached before the overloading threshold. Therefore it is necessary to use higher wanted signal levels to reach the onset of overload.

5.3 Frequency offsets between interfering signal and wanted signal

It is usual to use the following frequency offsets: 0, $\pm N$, $\pm(N+BW_I)$, $\pm(N+2 BW_I)$, $\pm(N+3 BW_I)$, $\pm(N+4 BW_I)$, and $9 BW_W$ (image channel).

Where:

$$N = (BW_W + BW_I)/2$$

BW_W : wanted signal bandwidth

BW_I : interfering signal bandwidth

However, regional specific frequency offsets could also be used, and smaller steps where more detailed investigation is required.

5.4 Measurements in the presence of a time varying interfering signal

An important difference between existing interference by other broadcast signals, and mobile signals is that in many cases the mobile signal power can exhibit significant time variation which can degrade the PR and O_{th} performance of some DTT receivers due to interfering with automatic gain control (AGC) and channel estimation algorithms. It is important to test against such types of interference. Time variation occurs in (at least) the following circumstances.

5.5 UMTS uplink

The UE can use TPC to improve performance in mobile reception conditions where the channel can be rapidly changing. The effect of this is for the UE to vary its transmit power rapidly over time in response to feedback messages from the BS.

5.6 LTE – downlink

The base station output power can vary over time if only some RB are used in each OFDMA symbol, or if some OFDMA symbols are completely empty. This tends to happen when the BS traffic loading is zero or at low levels. Consequently, in the presence of a BS interfering signal, it is recommended to carry out the measurements with different network traffic loadings of 0%, 50% and 100%.

5.7 LTE – uplink

The uplink signal can vary considerably in both the time and frequency domains depending upon the traffic loading required. In the frequency domain the number of RBs allocated for each SC-FDMA symbol can vary rapidly. In the time domain, there can be long periods where the UE does not transmit at all, leading to an irregular pulse like power profile.

Consequently, in the presence of a UE interfering signal, it is recommended to carry out the measurements with different data rates on the uplink. The modes should include both fully loaded continuous operation and time division multiplexed i.e. pulsed operation.

5.8 Interferer reference power level

Signal level variation can be from level reductions or time division occupancy. In order to be able to see the degradations caused by time variation in the interfering signal, it is necessary to set the appropriate rms power or power spectral density (psd) of the active portions of the time varying interference signal relative to the rms power or psd of the interferer with a 100% traffic loading (time invariant power condition).

5.9 Characterization of the interfering signal

Protection ratios and overloading thresholds of a receiver strongly depend on the frequency and time domain characteristics of the interfering signal used in the measurements. Therefore, it is necessary to record the psd, the adjacent channel leakage power ratio as well as the amplitude as function of time of the interfering signal. These pieces of information allow comparisons of different measurement results from different measurement campaigns.

5.10 Failure point assessment methods

Initial studies of the protection ratios for the DVB-T system were based on a target BER of 2×10^{-4} measured between the inner and outer codes, before Reed-Solomon decoding. For the case of a noise-like interferer, this has been taken to correspond to a quasi-error-free (QEF) picture quality with the BER $< 1 \times 10^{-11}$ at the input of the MPEG-2 demultiplexer.

For domestic receivers it may not be possible to measure the BER and therefore a new method called the SFP (subjective failure point) method has been proposed in Recommendation ITU-R BT.1368 for protection ratio measurements in a unified manner. The quality criterion for protection ratio measurements is to find a limit for a just error-free picture at the TV screen. The RF protection ratio for the wanted DVB-T signal is a value of wanted-to-unwanted signal ratio at the receiver input, determined by the SFP method, and rounded to the next higher integer value.

The SFP method corresponds to the picture quality where no more than one error is visible in the picture for an average observation time of 20 s. The adjustment of the wanted and unwanted signal levels for the SFP method is to be carried out in small steps, usually in steps of 0.1 dB. For a “noise-like” interferer the difference in a value of wanted-to-unwanted signal ratio between the QEF method with a BER of 2×10^{-4} and the SFP method is less than 1 dB. It is proposed that the SFP method should be adopted for assessment of all DTTB systems. (For the digital system ISDB-T this method will be studied in Japan.)

5.11 Method for determining protection ratios and overloading thresholds

It should be stressed that the protection ratios are generally considered and used as independent of the wanted signal level. That is $C(I)$ is supposed to be a linear function with unity slope (a straight line with unity slope). The protection ratio of the receiver is obtained by subtracting I from $C(I)$ at any points on this line and can be used for all wanted signal levels. However, the measurement results show that in most cases the protection ratios of wideband TV receivers vary as a function of the wanted signal level. Consequently, $C(I)$ is not a straight line with unity slope with some variation with the interfering signal strength. Nevertheless, for interfering signals below the overloading threshold such $C(I)$ curves can always be approximated by a straight line with unity slope with an acceptable error. This method has been used in this report for determining the PR of DTT receivers.

The method used for determining protection ratios and overloading thresholds is composed of two steps:

1. The measured $C(I)$ curve is approximated by a straight line with unity slope which represents the ideal linear behaviour of the receiver front-end (constant PR case). The protection ratio of the receiver is obtained by subtracting I from $C(I)$ at any points on this line. The protection ratio obtained can be used for all wanted signal levels.
2. A strong deviation of the measured $C(I)$ curve from the straight line with unity slope indicates where the interfering signal reaches the overloading threshold; i.e., the onset of strong non-linear behaviour. The deviated segment of $C(I)$ curve is approximated by a line vertical to I -axis (constant I case). The value of I at the point of intersection between the straight line with unity slope and the line vertical to I -axis is considered to be the receiver overloading threshold ($I = O_{th}$).

This two steps procedure is depicted in Fig. 4.

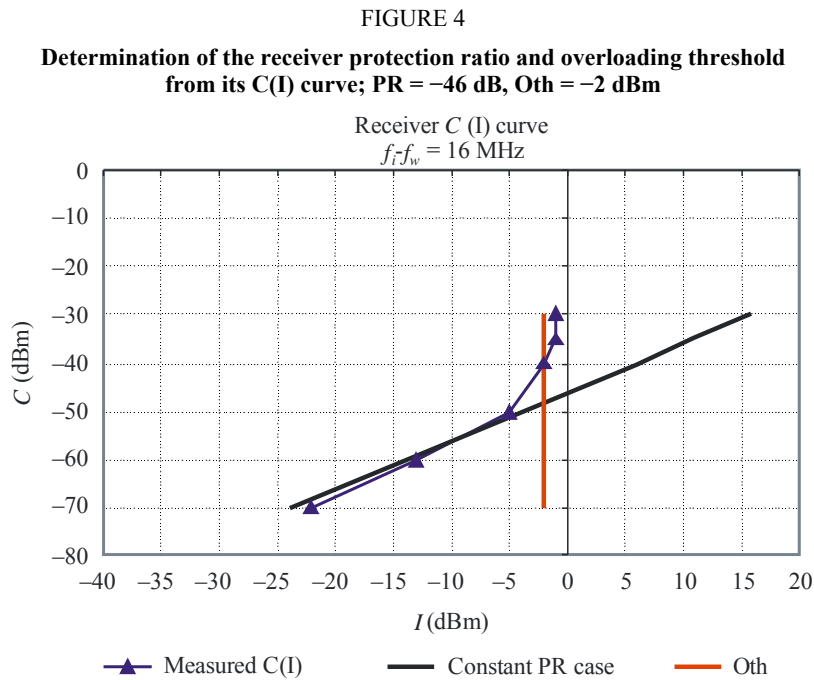

Report BT.2215-04

In some cases the approximation of a measured C(I) curve by a straight line with unity slope and a line vertical to I-axis may seem not to be very straight forward, but it is always possible to do it with an acceptable approximation error that should be in favour of the victim receiver.

Examples of approximations are shown in Figs 5 to 12. These examples use a wanted signal level range starting at -70 dBm, but lower levels are possible depending upon the sensitivity of the receiver mode being tested.

FIGURE 5

A well approximated C(I) curve; PR = -12 dB; overloading threshold is not reached

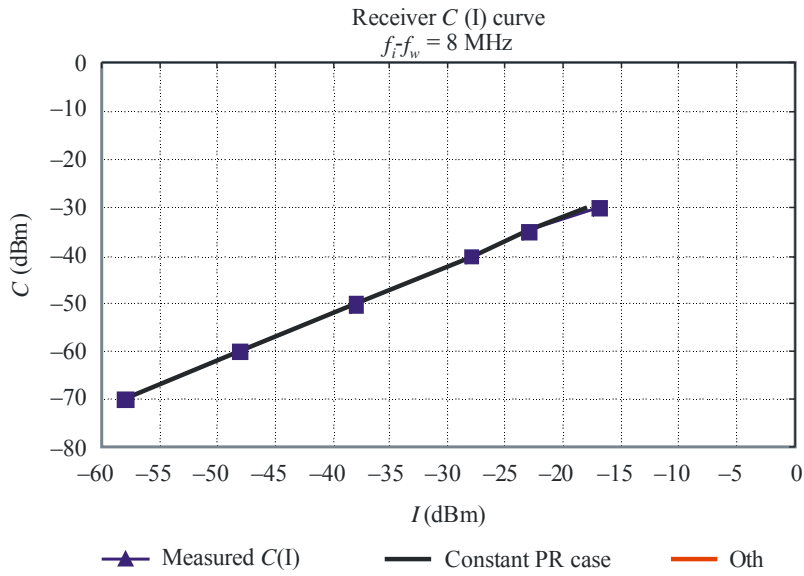

Report BT.2215-05

FIGURE 6

A well approximated C(I) curve; PR = -53 dB; $O_{th} = 10$ dBm

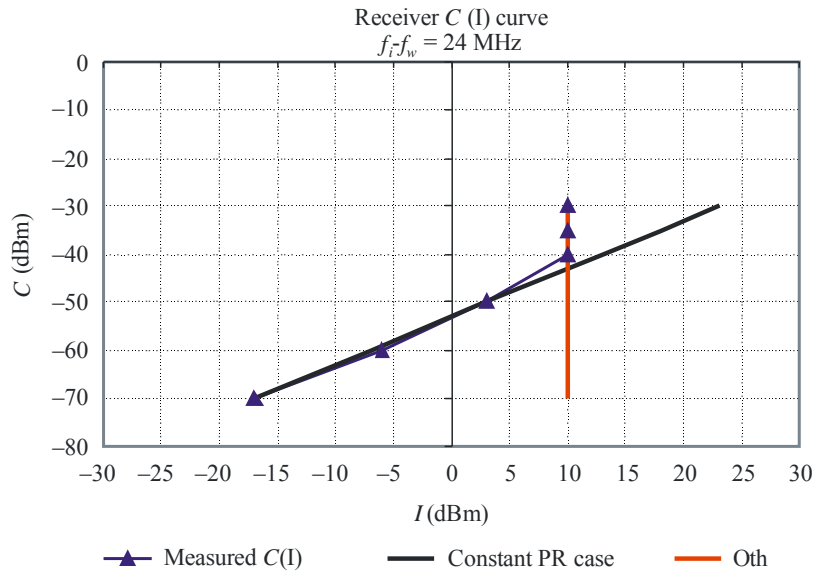

Report BT.2215-06

FIGURE 7

Some difficulties to determine the overloading threshold;
 PR = -39dB; Oth = -6 dBm

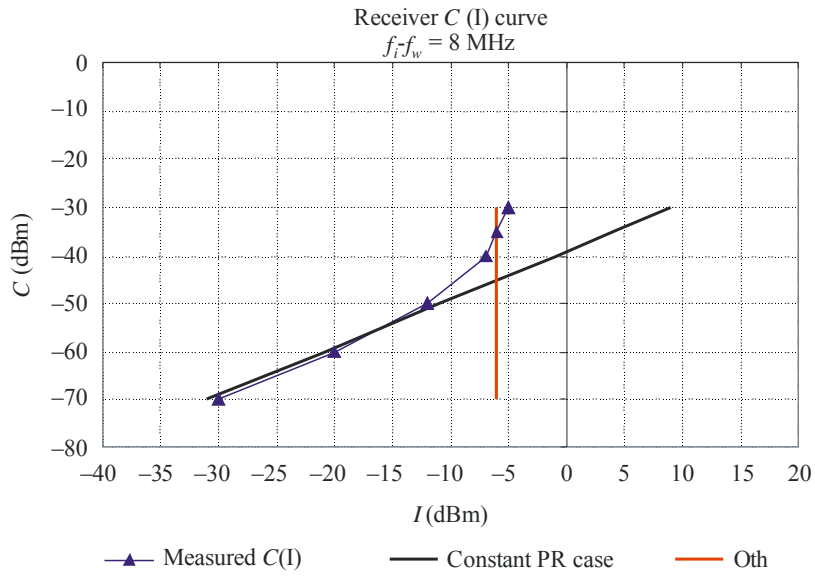

Report BT.2215-07

FIGURE 8

A well approximated C(I) curve; PR = -61 dB; Oth = 4 dBm

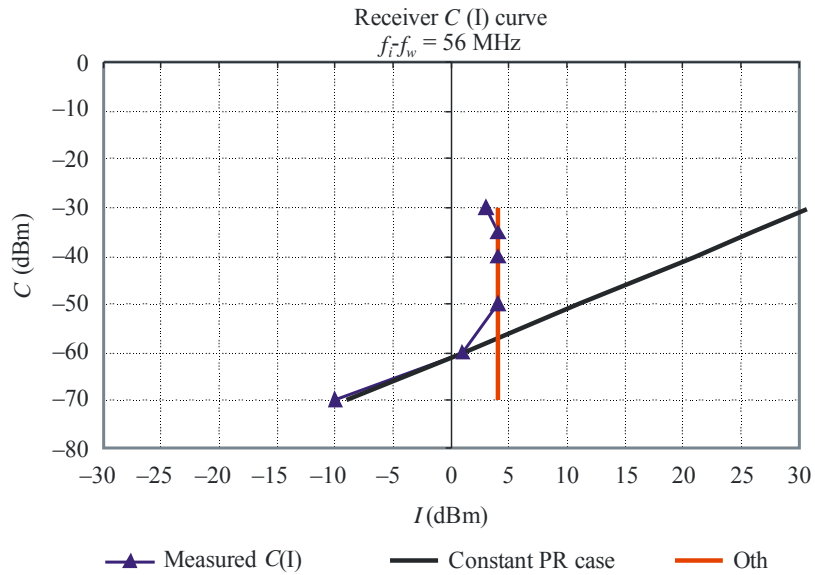

Report BT.2215-08

In the following example the receiver appears to behave in a non linear fashion when the interfering signal level reaches -21 dBm, but is quite linear for higher interfering signal levels up to 3 dBm.

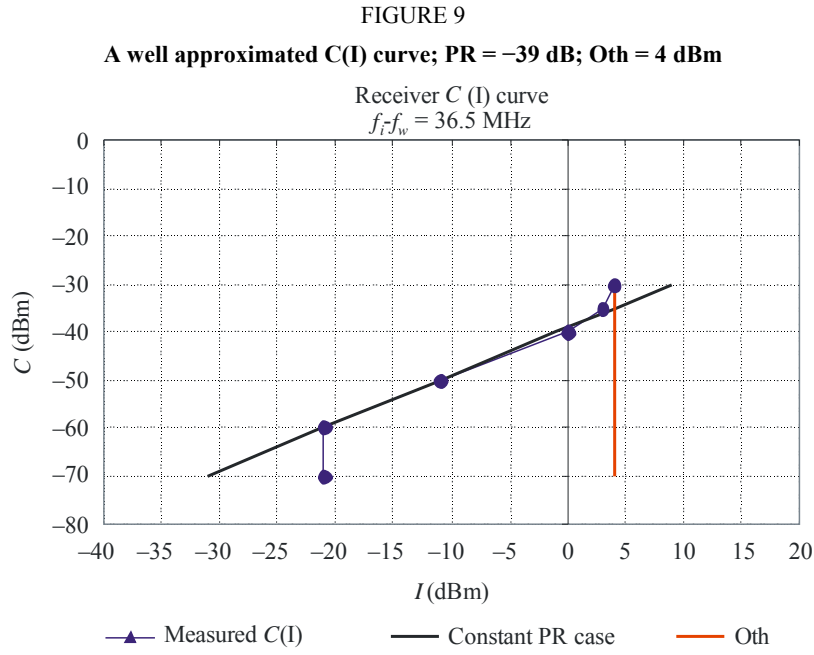

In the following example the O_{th} is reached at an interfering signal level of -24 dBm. However, the measured C(I) curve shows that an increase of the wanted signal level by about 30 dB allows the receiver to behave linearly once again but with a reduced PR (-16 dB instead of -48 dB).

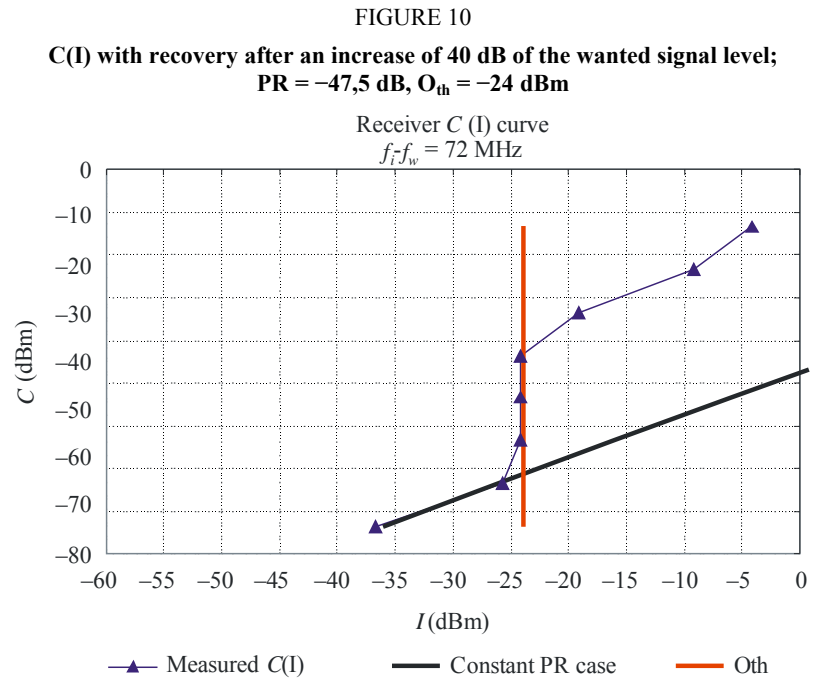

In the following examples the O_{th} is reached before the PR having been reached. In such cases the PR is obtained by subtracting I from $C(I)$ at the lowest intersection point between the straight line with unity slope representing the constant PR case and the line vertical to I -axis representing the constant I case.

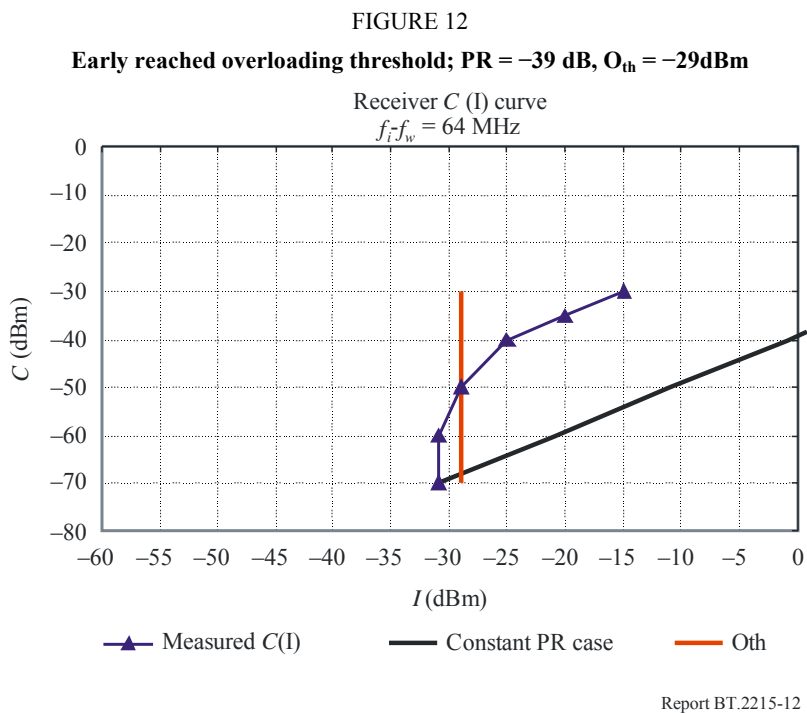
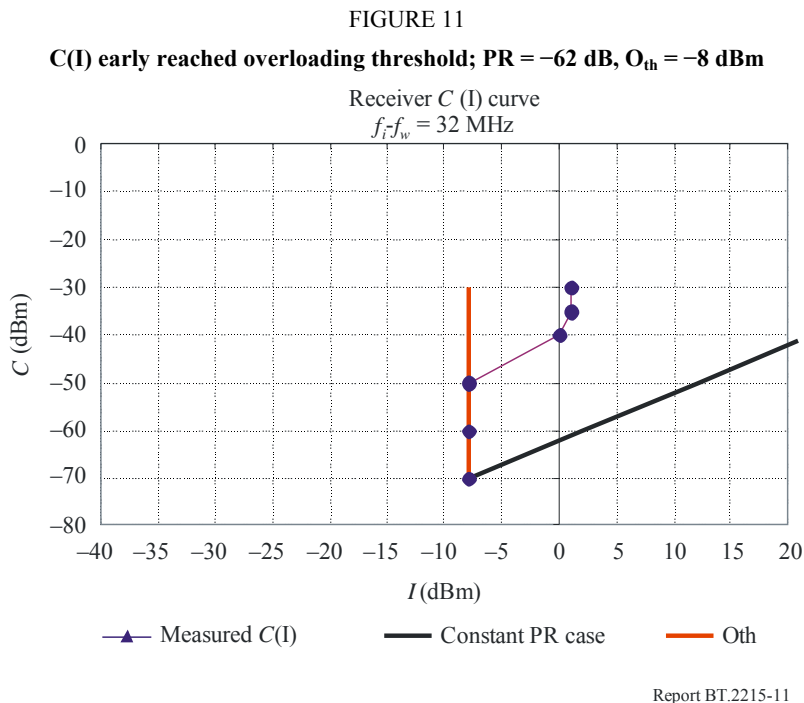

6 Conclusions and further work required

The results included in the annexes to this report are being used to improve and update Recommendation ITU-R BT.1368. They are also an opportunity to stimulate new areas of investigation for example the effects of time variation in interfering signals. Other Recommendations could also be considered as candidates for the material as required and a note added when required.

Where relevant the material in the annexes has a note indicating the version of Recommendation ITU-R BT.1368 which is amended, or another Recommendation where relevant. It is recommended that any future updates to this report add material together with similar notes of any particular version of a recommendation which relied on this information.

Additional results of receiver measurement tests are always welcome and are in some cases urgently needed for all the other major TV broadcasting standards such as DVB-T2, ISDB-T, ATSC, DTMB, so that the appropriate sections of Recommendation ITU-R BT.1368 can be filled with suitable PR and O_{th} data for assistance in network planning activities. Ideas for future contributions are highlighted in the annexes of this report.

Annexes

Annex 1

DVB-T receiver performance in the presence of interfering signals from DVB-T, UMTS and LTE

A.1.1.doc Measurements of protection ratios and overload thresholds for DVB-T receivers under interference from DVB-T in other channels

(Doc. 6/352)*

This information was used in the generation of Recommendation ITU-R BT.1368-8



Embedded-from
6A-364.doc

A.1.2.doc Measurements of protection ratio and overload threshold for DVB-T receivers under interference from UMT in other channels

(Doc. 6/352)*

This information was used in the generation of Recommendation ITU-R BT.1368-8



Embedded-from
6A-529.doc

* To be updated accordingly following the approval of Document 6/352, which is a revision of Recommendation ITU-R BT.1368-8.



Annex 4-6

Embedded from Document 6A/603 (Annex 4-6). This is included because it contains measurements of UMTS UE interference with different TPC speed profiles. Only can tuners were tested. Note the test methodology may differ from the recommended methodology used for other measurements in this report, and for future measurements.



Annex 4-9

Embedded from Document 6A/603 (Annex 4-9). Only can tuners were tested. Note the test methodology may differ from the recommended methodology used for other measurements in this report, and for future measurements.

A.1.3.doc Measurements of protection ratios and overload thresholds for DVB-T receivers under interference from LTE in other channels

(Doc. 6/352)*

This information was used in the generation of Recommendation ITU-R BT.1368-8

Embedded-from
6A-365.docEmbedded-from
6A-526.docEmbedded from
0398.docxR07-WP6A-C-0xxx!!
MSW-E_LTE_BS_INTC

Embedded from Document 6A/605. This contains recent (2011) measurements of LTE BS interference into 10 can and 10 silicon tuners using the recommended test methodology.

Microsoft Office
Word 97 - 2003 D

Embedded from Document 6A/606. This contains recent (2011) measurements of LTE BS interference into 5 can and 5 silicon tuners using the recommended test methodology.



Annex 4-7

Embedded from Document 6A/603 (Annex 4-7). This document is included because it includes measurements of interference in static and time varying Rayleigh channels. Note the test methodology may differ from the recommended methodology used for other measurements in this report, and for future measurements.
