



Report ITU-R BO.2007-2
(07/2014)

**Considerations for the introduction of
broadcasting-satellite services of
high-definition television and ultra-high
definition television systems
in the band 21.4-22 GHz**

BO Series
Satellite delivery



Foreword

The role of the Radiocommunication Sector is to ensure the rational, equitable, efficient and economical use of the radio-frequency spectrum by all radiocommunication services, including satellite services, and carry out studies without limit of frequency range on the basis of which Recommendations are adopted.

The regulatory and policy functions of the Radiocommunication Sector are performed by World and Regional Radiocommunication Conferences and Radiocommunication Assemblies supported by Study Groups.

Policy on Intellectual Property Right (IPR)

ITU-R policy on IPR is described in the Common Patent Policy for ITU-T/ITU-R/ISO/IEC referenced in Annex 1 of Resolution ITU-R 1. Forms to be used for the submission of patent statements and licensing declarations by patent holders are available from <http://www.itu.int/ITU-R/go/patents/en> where the Guidelines for Implementation of the Common Patent Policy for ITU-T/ITU-R/ISO/IEC and the ITU-R patent information database can also be found.

Series of ITU-R Reports

(Also available online at <http://www.itu.int/publ/R-REP/en>)

Series	Title
BO	Satellite delivery
BR	Recording for production, archival and play-out; film for television
BS	Broadcasting service (sound)
BT	Broadcasting service (television)
F	Fixed service
M	Mobile, radiodetermination, amateur and related satellite services
P	Radiowave propagation
RA	Radio astronomy
RS	Remote sensing systems
S	Fixed-satellite service
SA	Space applications and meteorology
SF	Frequency sharing and coordination between fixed-satellite and fixed service systems
SM	Spectrum management

Note: This ITU-R Report was approved in English by the Study Group under the procedure detailed in Resolution ITU-R 1.

Electronic Publication
Geneva, 2014

© ITU 2014

All rights reserved. No part of this publication may be reproduced, by any means whatsoever, without written permission of ITU.

REPORT ITU-R BO.2007-2

**Considerations for the introduction of broadcasting-satellite services of
high-definition television and ultra-high definition television systems*
in the band 21.4-22 GHz**

(Question ITU-R 279/4)

(1995-1998-2014)

TABLE OF CONTENTS

	<i>Page</i>
1 Introduction	2
2 Regulatory provisions.....	2
3 Status of existing services.....	2
4 Power flux-density limits for transmitting stations in the 21.4-22 GHz band.....	4
5 Service requirements	4
5.1 Overall system objectives	4
5.2 Service and coverage requirements	4
5.3 Multiplex-related requirements	5
5.4 Receiver requirements	5
6 Service availability	5
7 Scenarios for usage of the 21 GHz band	6
8 Standardization process	7
9 Special applications	7
10 Feeder links.....	7
Annex 1 – Possible coding and modulation approaches to improve service availability for digital BSS (HDTV)	9
Annex 2 – Satellite transmission experiment of live UHDTV (7 680 × 4 320 pixels) or Super Hi-Vision (SHV) pictures using WINDS	17
Annex 3 – Bandwidth efficient coding and modulation schemes for wideband HDTV applications supported by satellite and cable networks.....	20
Annex 4 – Possible exploitation of the BSS 21.4-22.0 GHz bank for HDTV.....	35
Annex 5 – Mission scenario for European 20 GHz digital BSS (HDTV)	38
Annex 6 – Trial 4k (3 840 × 2 160 pixels) UHDTV broadcasting using COMS in Republic of Korea.....	40

* HDTV (High-Definition Television) and UHDTV (Ultra-High Definition Television) are specified in Recommendations ITU-R BT.709 and ITU-R BT.2020, respectively.

1 Introduction

The World Administrative Radio Conference for Dealing with Frequency Allocations in Certain Parts of the Spectrum (Malaga-Torremolinos, 1992) (WARC-92) made an allocation in the bands 21.4-22.0 GHz in Regions 1 and 3 and 17.3-17.8 GHz in Region 2 to the broadcasting-satellite service (BSS) on a primary basis from 1 April 2007. Use of the 21.4-22 GHz band by satellite networks in the BSS in Regions 1 and 3, prior to 18 February 2012, was subject to an interim procedure in accordance with Resolution **525 (WARC-92, Rev.WRC-03 and Rev.WRC-07)**. Taking into account the study results in accordance with Resolution **551 (WRC-07)**, the World Radiocommunication Conference (Geneva, 2012) (WRC-12) has established definitive arrangements for the use of this frequency band in accordance with Resolution **552 (WRC-12)**, Resolution **553 (WRC-12)**, Resolution **554 (WRC-12)** and Resolution **555 (WRC-12)**.

In addition, the band 21.4-22 GHz is allocated on a primary basis to the BSS in Regions 1 and 3 and to the fixed and mobile services in all three Regions. The co-existence between the BSS and the terrestrial services is regulated through hard power flux-density (pfd) limits in accordance with Resolution **755 (WRC-12)**.

This Report lists a number of characteristics to be considered in the development of BSS (HDTV) systems in the 21.4-22 GHz band in Regions 1 and 3. The material in §§ 5, 6 and 7, and in the Annexes to this Report may also be of interest for system planning in the 17.3-17.8 GHz band in Region 2. Likewise, this material may be of interest in connection with the possible accommodation in the 12 GHz band of BSS (HDTV) systems, particularly for the tropical countries of Regions 1 and 3. The example UHDTV experiments in Annexes 2 and 6 provide the configuration of reference satellite broadcasting system for real-time and non-real-time, respectively. The administrations who intend to implement a UHDTV system can refer to this Report in regulatory and technical aspects in the band 21.4-22 GHz.

2 Regulatory provisions

WRC-12 decided on the spectrum usage of the 21.4-22 GHz band to ensure the equitable access to the orbital and spectrum resources as stipulated in Article 44 of the ITU Constitution leading to Resolution **552 (WRC-12)**, Resolution **553 (WRC-12)**, Resolution **554 (WRC-12)** and Resolution **555 (WRC-12)**.

In addition, the provisions of Articles **5** and **21**, and Resolution **755 (WRC-12)** of the Radio Regulations stipulated pfd limits for the spectrum usage of the 21.4-22 GHz band, since the BSS in Regions 1 and 3 have the same regulatory status as the terrestrial services with a primary allocation in this band in all three Regions.

3 Status of existing services

The band 21.4-22.0 GHz is also allocated to the fixed and mobile services on a primary basis.

Based on the provisions of RR Articles **5** and **21**, and Resolution **755 (WRC-12)**, transmitting stations in the fixed and mobile services in all three Regions are subject to the pfd limit specified in RR No. **5.530A** by 31 December 2015, or the first day of the next world radiocommunication conference, and the transmitting space stations in the broadcasting-satellite service in Regions 1 and 3 are subject to pfd limits specified in RR No. **21.16**.

TABLE 1

General scheme of applicable procedures to implement BSS (HDTV) systems

Date of use of HDTV band	Conditions		Applicable RR provisions
	Experimental systems		<p>Article 27: Experimental stations</p> <p>Res. 33 (Rev.WRC-03), Sect. A: Coordination procedure between space stations in the broadcasting-satellite service and terrestrial stations</p> <p>Res. 33 (Rev.WRC-03), Sect. B: Coordination procedure between space stations in the broadcasting-satellite service and space systems of other administrations</p> <p>Res. 33 (Rev.WRC-03), Sect. C: Notification, examination and recording in the Master Register of assignments to space stations in the BSS dealt with under this Resolution</p>
Before 18 February 2012	Operational systems	pfd > a	<p>Res. 33 (Rev.WRC-03), Sect. A: Coordination procedure between space stations in the broadcasting-satellite service and terrestrial stations</p> <p>Res. 33 (Rev.WRC-03), Sect. B: Coordination procedure between space stations in the broadcasting-satellite service and space systems of other administrations</p> <p>Res. 33 (Rev.WRC-03), Sect. C: Notification, examination and recording in the Master Register of assignments to space stations in the BSS dealt with under this Resolution</p>
		pfd < a	<p>Res. 33 (Rev.WRC-03), Sect. B: Coordination procedure between space stations in the broadcasting-satellite service and space systems of other administrations</p> <p>Res. 33 (Rev.WRC-03), Sect. C: Notification, examination and recording in the Master Register of assignments to space stations in the BSS dealt with under this Resolution</p>

TABLE 1 (*end*)

Date of use of HDTV band	Conditions	Applicable RR provisions
After 18 February 2012	All system	<p>Res. 33 (Rev.WRC-03), Sect. B: Coordination procedure between space stations in the broadcasting-satellite service and space systems of other administrations</p> <p>Res. 33 (Rev.WRC-03), Sect. C: Notification, examination and recording in the Master Register of assignments to space stations in the BSS dealt with under this Resolution</p> <p>Res. 552 (WRC-12), Long-term access to and development in the band 21.4-22 GHz in Regions 1 and 3</p> <p>Res. 553 (WRC-12), Additional regulatory measures for broadcasting-satellite networks in the band 21.4-22 GHz in Regions 1 and 3 for the enhancement of equitable access to this band</p> <p>Res. 554 (WRC-12), Application of pfd masks to coordination under No. 9.7 for broadcasting-satellite service networks in the band 21.4-22 GHz in Regions 1 and 3</p> <p>Res. 555 (WRC-12), Additional regulatory provisions for broadcasting-satellite service networks in the band 21.4-22 GHz in Regions 1 and 3 for the enhancement of equitable access to this band</p>
<p>a: limits defined in § 4 of this Report.</p> <p>pfd: power flux-density.</p>		

4 Power flux-density limits for transmitting stations in the 21.4-22 GHz band

The limits of pfd at the Earth's surface produced by emissions from a space station on the territory of any other country are:

- -115 dB(W/m²) in any 1 MHz band for angles of arrival between 0° and 5° above the horizontal plane; or
- -105 dB(W/m²) in any 1 MHz band for angles of arrival between 25° and 90° above the horizontal plane; or
- values to be derived by linear interpolation between these limits for angles of arrival between 5° and 25° above the horizontal plane.

The limit of pfd from a single fixed or mobile station is:

- -120.4 dB(W/(m² · MHz)) at 3 m above the ground of any point of the territory of any other administration in Regions 1 and 3 for more than 20% of the time.

5 Service requirements

Further study is needed on the detailed development of service requirements for BSS HDTV and UHDTV. A set of provisional requirements is listed below:

5.1 Overall system objectives

- a) An agreed standard for satellite broadcasting of digital HDTV (see also § 9).
- b) The transmission standard should be applicable to other relevant media with the minimum conversion complexity.
- c) The emitted signal shall be received by small (45-90 cm) individual antenna installation. It should also be suitable to feed cable head-ends.

5.2 Service and coverage requirements

- a) HDTV and UHDTV are intended for fixed reception with highest quality possible within HDTV and UHDTV format (virtual studio quality).
- b) Service availability for a percentage of the time of the worst-month (service continuity for digital systems is normally determined by the drop-out point) to be determined by further study (see also § 6).
- c) Subjectively acceptable failure characteristics. In the 21 GHz range, this might require attenuation mitigation techniques such as layered modulation and channel coding as well as adaptive satellite e.i.r.p. control, providing standard definition TV (SDTV) and/or limited definition TV (LDTV) quality only in case of deep fadings. The detailed mitigation techniques are described in Recommendation ITU-R BO.1659-1.

Important note – Sound should not fail before the picture.

- d) The choice of a technically suitable modulation technique to achieve (to the extent possible) high spectrum-efficiency, low transmit power and low protection ratios in order to maximize frequency reuse and minimize sharing constraints with the same and other services. The detailed system parameters are described in Report ITU-R BO.2071-1.
- e) Possibility for national, multinational and subnational coverage.
- f) Provisions for scrambling with the aim of spectrum shaping for energy dispersal.
- g) Provisions for conditional access.

5.3 Multiplex-related requirements

- a) All service elements related to one complete programme service have to be combined using adequate multiplexing techniques.
Service elements will include sound, picture and data and, optionally, baseband error protection.
- b) Fixed gross bit rate at the output of the multiplexer.
- c) Flexible multiplex configuration with dynamic reconfiguration. (This includes frequent transmission of multiplex configuration information.)
- d) Common multiplex and service information (SI) for the various delivery systems.

5.4 Receiver requirements

- a) User friendliness.
- b) Acceptable receiver cost in mass production.
- c) Maximum of commonality in signal processing for different delivery media, such as satellite, terrestrial and cable transmission.
- d) Capability of receiving full quality digital HDTV and UHDTV signals delivered by satellite, terrestrial and cable networks (optionally in combination with existing TV signals).

6 Service availability

The availability of the BSS (HDTV and UHDTV) needs to be given urgent further study. Some Administrations are proposing 99.6% to 99.7% of the worst-month for service continuity. It is noted that since the HDTV and UHDTV systems will probably be digital, the systems will experience rapid degradation and not the gradual degradation experienced in analogue systems. Careful selection of the coding and modulation may improve the service availability. Annexes 1 and 3 give possible approaches to this topic.

Studies have been performed by Italy on advanced error protection strategies for digital TV/HDTV satellite provisioning. These strategies make use of an “inner” convolutional/trellis code associated with the digital modem and an “outer” block code associated to the video codec to minimize the bit error ratio (BER). In receivers operating at high bit rates the use of “parallel Viterbi” chips may be necessary and this can cause a coding gain degradation. Italy is studying (Doc. 10-11S/97 and Task Group (TG) 11/2) techniques to avoid this degradation.

Adaptive satellite e.i.r.p. control using array-fed satellite antenna can provide another useful means to improve service availability especially for countries which have high density rainfalls. Annex 2 to Report ITU-R BO.2071-1 gives a concept of this approach.

It is expected that BSS (HDTV and UHDTV) at 17 and 21 GHz has to cope with large attenuation in most countries. Service availability criteria should be discussed in the context of expected attenuation values and corresponding mitigation strategies.

Further study is needed on the topic of service availability and new mitigation technologies.

7 Scenarios for usage of the 21 GHz band

Europe, Japan and the Republic of Korea are now working on various research projects (e.g. HD-SAT in Europe) to overcome the technical challenges of exploiting the 21 GHz band in order to prepare for operation of studio-quality (wide-RF band) HDTV, integrated services digital broadcasting (ISDB) BSS and UHDTV in this band. A main goal of the HD-SAT project is to respond to the service requirements set forth in § 5 of this Report. In June 1995, the HD-SAT project demonstrated to the public digital high-quality HDTV live over a 30/20 GHz satellite link. Both, sound and picture were MPEG-2 coded and decoded in real-time. Graceful degradation was achieved and demonstrated applying a two-layer modulation concept carrying the HDTV and SDTV versions of the same programme. Interlinking with cable distribution and terrestrial emission of HDTV was also part of the live presentation. The convincing demonstration proved in principle the technical feasibility of a 30/20 GHz studio-quality digital HDTV broadcasting satellite service (see Annex 3). In addition, a satellite mission scenario for Europe was studied, concluding that a central European coverage would be possible with some 55 dBW of e.i.r.p. (see Annex 5).

Japan launched in 2008 an experimental satellite WINDS (Wideband InterNetworking engineering test and Demonstration Satellite), including an 18 GHz band mission, to develop high speed satellite communications. The bandwidth of the WINDS is 1 100 MHz (maximum). The output power is 280 W (maximum) and the e.i.r.p. is over 68 dBW. New high-data rate broadcasting services supporting UHDTV and three-dimensional representation are also a development goal in Japan. The satellite transmission experiment of live UHDTV (7 680 × 4 320 pixels) or Super Hi-Vision (SHV) pictures using WINDS carried out in 2009 is described in Annex 2.

The Republic of Korea launched in 2010 the satellite COMS (Communication, Ocean and Meteorological Satellite), including missions around the 20 GHz band, for experimental purposes. In 2013, ETRI and KTSkylife performed the trial 4k UHDTV broadcasting using COMS. Also, in order to overcome the high rain attenuation, the hierarchical satellite UHD/HD/SD broadcasting test system based on simulcast technology is under development.

The ITU-R established comprehensive Reports on HDTV and UHDTV satellite broadcasting in this band (Reports ITU-R BO.1075 and ITU-R BO.2071) and is working on flexible planning concepts for this service. After the completion of the RACE HD-SAT Project, which includes studies by the RAI on possible spectrum management strategies, first results are now available. These are presented in detail in Annex 4. Main parameters will be the maximum permissible pfd and the maximum acceptable interference level expressed in terms of link budget reduction.

While in the near future Europe will introduce digital multi-programme satellite TV (“multivision”), digital HDTV is a longer term concept, which may require an early access to the 21 GHz frequency band only if studio-like picture quality is anticipated. In any case the new band may not only help to ensure the future of satellite broadcasting but also that of the consumer television industry.

8 Standardization process

It is necessary to define the service and the associated key parameters in order to obtain the maximum efficiency when using the new frequency allocation.

It is known that the GSO is a limited resource. It is also known that the best way to obtain the maximum efficiency in the use of the orbit-spectrum resource is by proper implementation of the systems with a certain level of uniformity in their key parameters.

The implementation of wideband HDTV and UHDTV systems will be promoted when service objectives have been agreed by broadcast organizations, major BSS operators and industry.

To do that, it will be necessary to assess all the items that contribute to a complete characterization of the BSS (HDTV and UHDTV) systems such as:

Service objectives:

- service quality;
- service reliability.

System characteristics:

- propagation factors;
- source coding of wideband HDTV (W-HDTV) and UHDTV signals;
- modulation and channel coding;
- receiving system characteristics;
- satellite and earth station technology.

Spectrum management:

- procedures for flexible usage of this band (up-link and down-link);
- total bandwidth required by each service;
- protection ratios;
- sharing with fixed and mobile services.

The results of the research projects currently carried out in Europe and Japan for the opening up of the 21 GHz band for W-HDTV and multi-service ISDB satellite broadcasting will provide the basis for determining the aforementioned technical parameters.

9 Special applications

Special applications may require transmission standards which are different from those commonly used. For special events, satellite news gathering (SNG) in the fixed-satellite service (FSS) may be employed. Furthermore, there may be times when it is desirable for the signal to be sent straight to the BSS satellite instead of via a studio.

A number of SNG terminals do not operate at bit rates of 140 Mbit/s but use lower rates such as 68 or 34 Mbit/s or lower. Further study is needed on how these special applications may be accommodated in the BSS (HDTV) environment.

10 Feeder links

Before WRC-12, there was no appropriate capacity available in Region 1 that allowed a 600 MHz band to be used for feeder links for the BSS in the 21.4-22 GHz band. In Region 3, the bands 24.75-25.25 GHz and 27-27.5 GHz could be used for feeder links for the BSS in the 21.4-22 GHz band. However, these bands are just 500 MHz wide, lacking 100 MHz to provide a continuous 600 MHz feeder link bandwidth.

For this reason, WRC-12 decided additional allocations for feeder links for the BSS (21.4-22 GHz) in the band 24.65-25.25 GHz in Region 1 and in the band 24.65-24.75 in Region 3. The use of these bands for feeder links shall comply with RR No. **5.532B**.

Bibliography

All issues mentioned are treated within the research work (see for example [Takahashi *et al.*, 2009; Dosch, 1994; Palicot y Veillard, 1993]).

COMINETTI, M. *et al.* [Summer 1992] EBU demonstrations of wideband digital HDTV satellite broadcasting technologies at WARC-92. EBU Tech. Rev. 252, Geneva, Switzerland.

DOSCH, Ch., [Summer 1994] Inter-operability of digital HDTV satellite broadcasting (21.4-22 GHz) with the existing and future media infrastructure. Status of the HD-SAT project. EBU Tech. Rev., 260, 51-63.

MERTENS, H. Spectrum and planning aspects for digital HDTV satellite broadcasting in [EBU, 1992].

PALICOT, J. and VEILLARD, J. [1993] Possible channel, coding and modulation system for the satellite broadcasting of a high-definition television signal. Signal Processing: Image Communication 5, 463-471.

TAKAHASHI, T., SUZUKI, R., TANAKA, S. [October 2009] WINDS High Speed Communication Experiments – SHV transmission experiment – Proc. Next Generation Satellite Communications and Applications (NGSCA 2009), Korea.

EBU [February, 1992] Advanced techniques for satellite broadcasting of digital HDTV at frequencies around 20 GHz. Collected papers on the concepts for wideband digital HDTV Published by EBU on the occasion of demonstrations of wideband HDTV satellite broadcasting technologies during the ITU WARC-92 Conference (Malaga-Torremolinos, 1992), Geneva, Switzerland.

Annex 1

Possible coding and modulation approaches to improve service availability for digital BSS (HDTV)

1 Introduction

WARC-92 allocated the frequency band 21.4-22.0 GHz to BSS (HDTV) in Regions 1 and 3 and the band 17.3-17.8 GHz in Region 2. Due to severe atmospheric attenuation levels in these frequency bands and in the 12 GHz BSS band for tropical countries, conventional digital techniques exhibiting abrupt breakdown failure characteristics may not be able to provide the required service availability without exceeding pfd limits under clear-sky conditions.

In this Annex, new coding/modulation approaches are considered to improve service availability of digital BSS (HDTV).

The advanced approaches outlined in this Annex achieve a graceful degradation of HDTV service during high rain fades; this behaviour is very similar to that of analogue systems which is well accepted by television viewers. Most of the time, e.g. for up to 99% of the worst-month, the service provides nominal HDTV quality, while during heavy rain fades, the receiver provides standard broadcast TV quality and/or LDTV quality. (see Note 1).

NOTE 1 – In Europe and in the United States of America, studies on the graceful degradation concept based on layered modulation are also undertaken for terrestrial emission of HDTV signals in order to adapt the service to different receive conditions (e.g. fixed and portable receivers). In the case of HDTV-BSS the concept of layered modulation provides for increased service continuity during high precipitation fades rather than for receiving optionally TV signals of lower resolution.

2 Examples of the layered modulation approach

2.1 Example 1

This example is based on an RF time multiplex combining various types of modulation [Palicot and Veillard, 1993a].

The conceptual coding/modulation approaches are built around a frame (see Fig. 1) consisting of two parts:

- Part 1 (R_1): HDTV component with high bit-rate signal of duration T_1 ;
- Part 2 (R_2): SDTV component with low bit-rate signal of duration T_2 .

FIGURE 1
Time multiplex of high and low bit-rate components

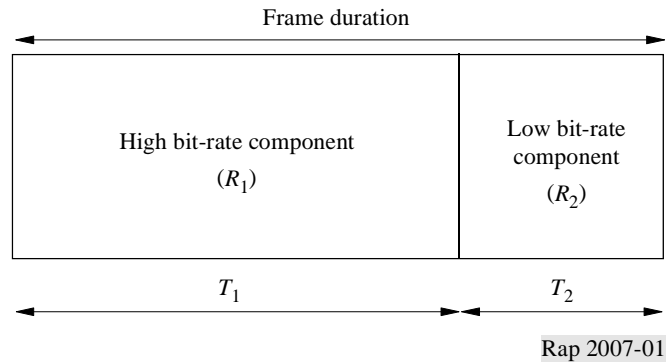

The low bit-rate R_2 signal is associated with a channel coding and modulation which are more robust in presence of noise than the channel coding and the modulation associated with the high bit-rate signal.

During severe atmospheric attenuations, the receiver automatically switches from the HDTV component to the SDTV component. The switching criterion can be related to the received power or to the BER of the HDTV component. For a given satellite transmitted power, this approach allows to extend the service continuity and hence to reduce the service outage time.

At the transmission side (Fig. 2), the HDTV signal is down-sampled and a compatible 625-line picture is obtained which is applied to coder 2. The residual component (difference between HDTV input and locally decoded output of coder 2) is coded by coder 1. This scheme allows to reduce the transmitted data rate or to increase the portion of the data rate allocated to the picture component in the multiplex.

At the reception site (Fig. 3), up-sampling (H:2/1, V:2/1) is carried out for the output of decoder 2 and the resulting information combined with the output of decoder 1 reconstructs the whole HDTV picture.

In order to compare the approaches outlined above with a reference system (the reference system is a system that uses a single bit rate), it is assumed that the bit rate after HDTV coding is the same for a convention coder and for a compatible coder.

Figure 4 shows the failure characteristic of a compatible example compared to the reference system [Palicot and Veillard, 1993b]. This figure exhibits hysteresis when switching between two service qualities to prevent excessively frequent switching.

FIGURE 2
Example of compatible coding and modulation scheme

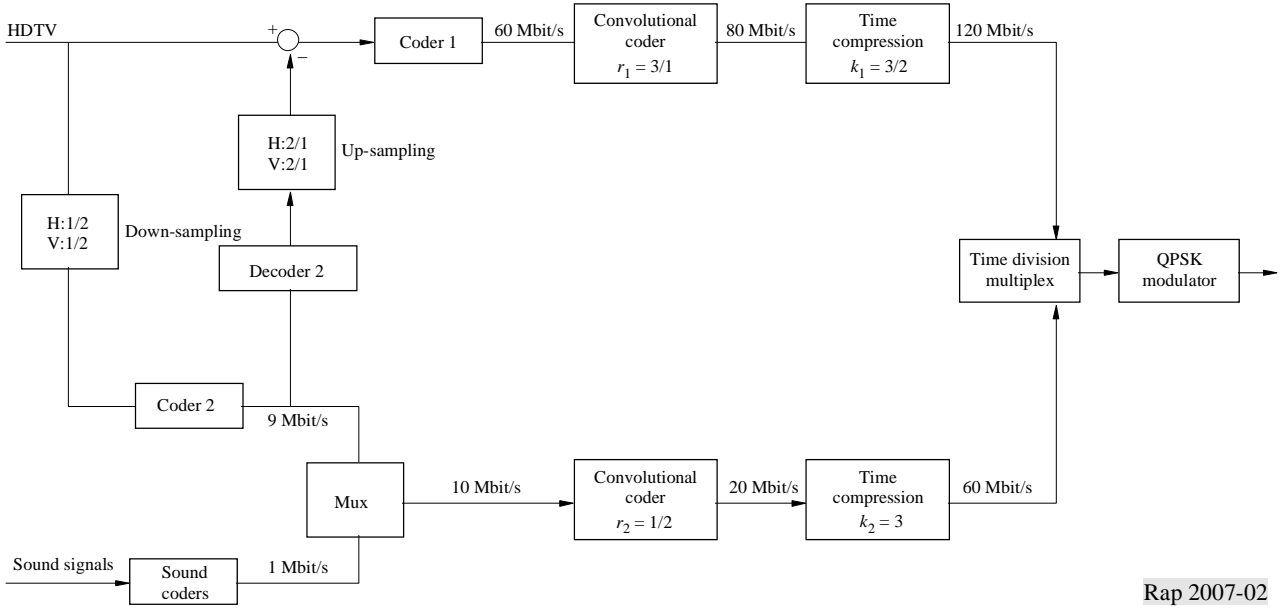

Rap 2007-02

FIGURE 3
Example of compatible decoding and demodulation scheme

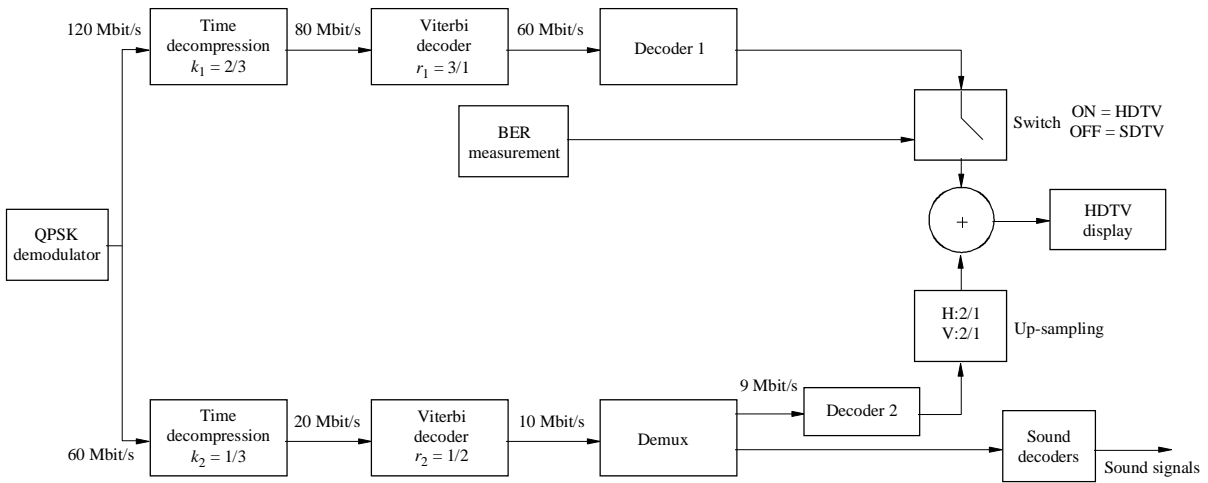

Rap 2007-03

FIGURE 4

Picture/sound quality versus C/N : Comparison of failure characteristics between the compatible coding example and the reference system

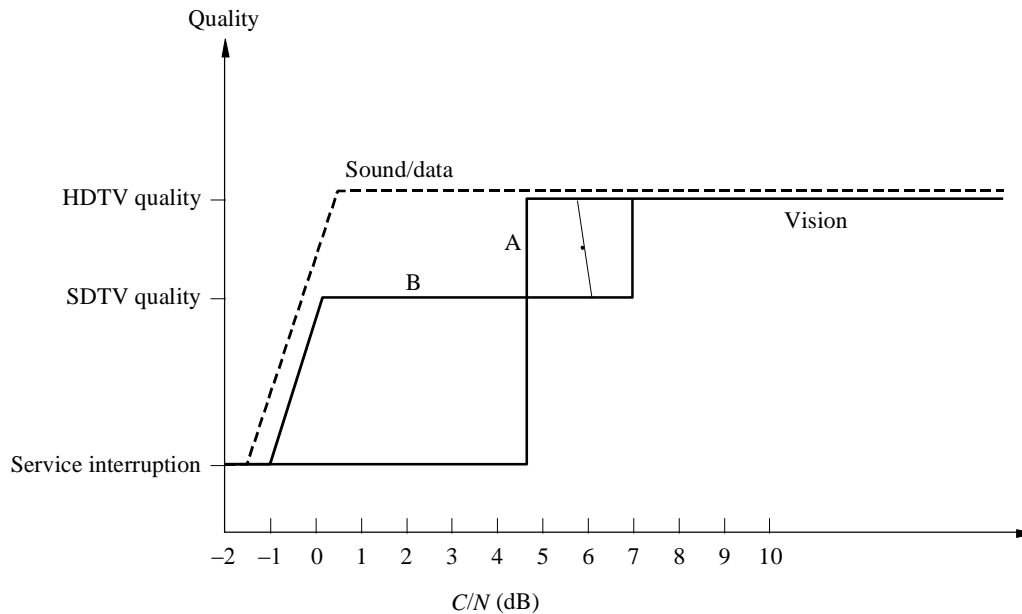

A: reference system (single bit rate)
B: compatible coding example

Rap 2007-04

2.2 Example 2

This example shows a layered modulation approach with three layers [Tsuzuku, *et al.*, 1993]. In other words, this example can realize graceful degradation with three grades.

As regards source coding, HDTV information is divided into three digital data streams according to the principle shown in example 1. For example, the data streams are a VCR quality component, a difference component between SDTV and VCR quality, and a difference component between HDTV and SDTV quality. These three data streams are transmitted by the following hierarchical modulation method.

The principle of this hierarchical modulation is controlling the Euclidean distance of the symbol. The constellation of the nominal 8-PSK is shown in Fig. 5a). However, the immunity from the noise can be changed by taking a different distance between each symbol. An example of the constellation of the hierarchical 8-PSK is shown in Fig. 5b). The 8-PSK symbol can transfer 3 bits, and each bit has different immunity from the noise by different Euclidean distance.

The BER characteristics of the hierarchical modulation shown in Fig. 5b) is derived theoretically. The results are shown in Fig. 6. The BER of the first bit is the same as that of QPSK, the second bit is almost the same as that of the normal 8-PSK, and the third bit is nearly equal to that of 16-PSK. If the required BER is 10^{-4} (before error correction), the frequency utilization efficiency vs. C/N ratio is shown in Fig. 7. Using this modulation, when the C/N ratio is more than 22.6 dB, we can transfer the data 1.5 times as much as the QPSK.

2.3 Example 3

A further example of a layered modulation approach with three layers is given in §§ 3 and 4 of Annex 3.

FIGURE 5

Principle of graceful degradation by hierarchical 8-PSK modulation

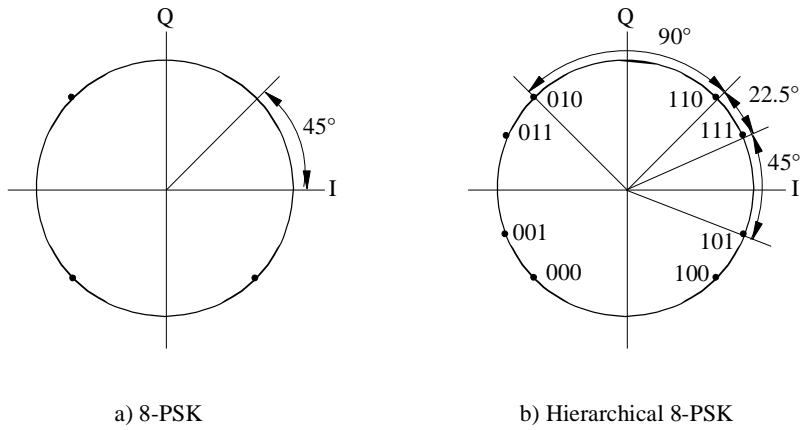

Rap 2007-05

FIGURE 6

Bit error rate characteristics of hierarchical 8-PSK

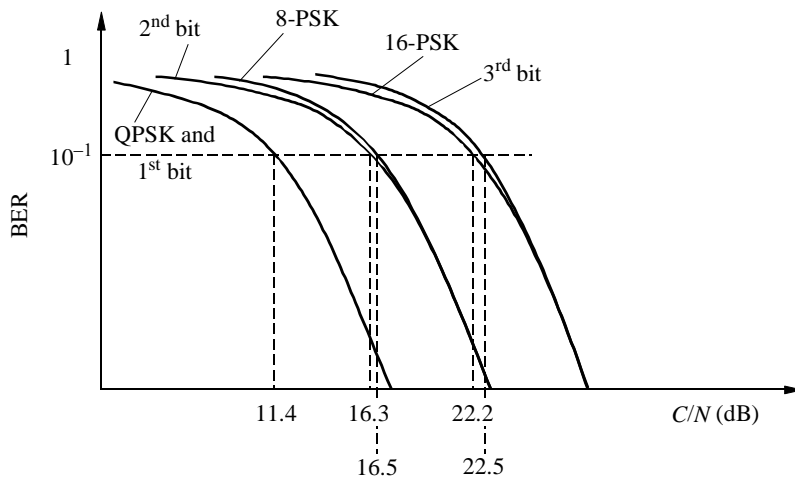

Rap 2007-06

FIGURE 7
Frequency utilization of hierarchical 8-PSK

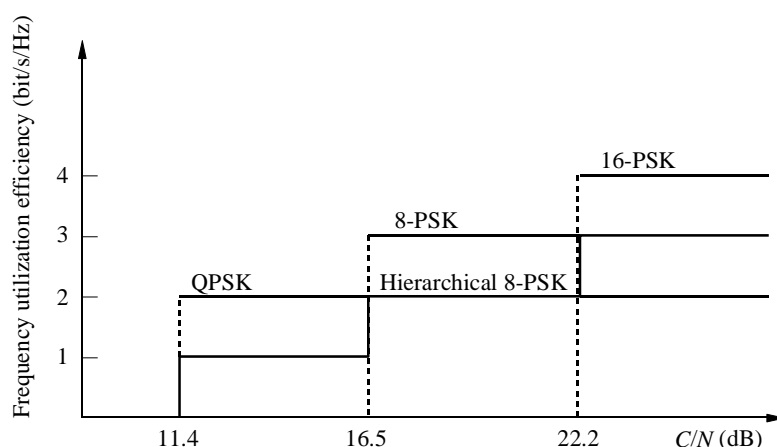

Rap 2007-07

3 Fading characteristics due to heavy rain

Digital systems have rapid failure characteristics, so profiles of fading due to heavy rain affect the service availability of the system.

Examples of C/N fading due to heavy rain at 22 GHz are shown in Fig. 8. These profiles are estimated using a C/N drop profile measured at 12 GHz in Tokyo with the Japanese BS-3 broadcasting satellite and the method described in ex-CCIR Report 721. The rapid and deep fading characteristics in the 21 GHz band appear in the figures.

The lines for service interruption in the figures are calculated from the data described in example 1 in § 2.1. As a transmission parameter, we assume 70 dBW satellite e.i.r.p., a 45 cm diameter reception antenna and 2.0 dB noise figure. Service outage time as estimated from the figure is summarized in Table 2.

TABLE 2
Service outage time by layered and non-layered transmission
based on the examples in Figs. 8a) and 8b)

Example	Scheme	Service outage time (min)	Outage ratio to non-layered system (%)
a) Case of a Storm	Non-layered	3.6	–
	Layered (HQ layer)	4.0	111
	Layered (LQ layer)	2.0	56
b) Case of a Typhoon	Non-layered	11.4	–
	Layered (HQ layer)	12.5	110
	Layered (LQ layer)	7.1	62

FIGURE 8
Examples of C/N fading due to rain at 22 GHz

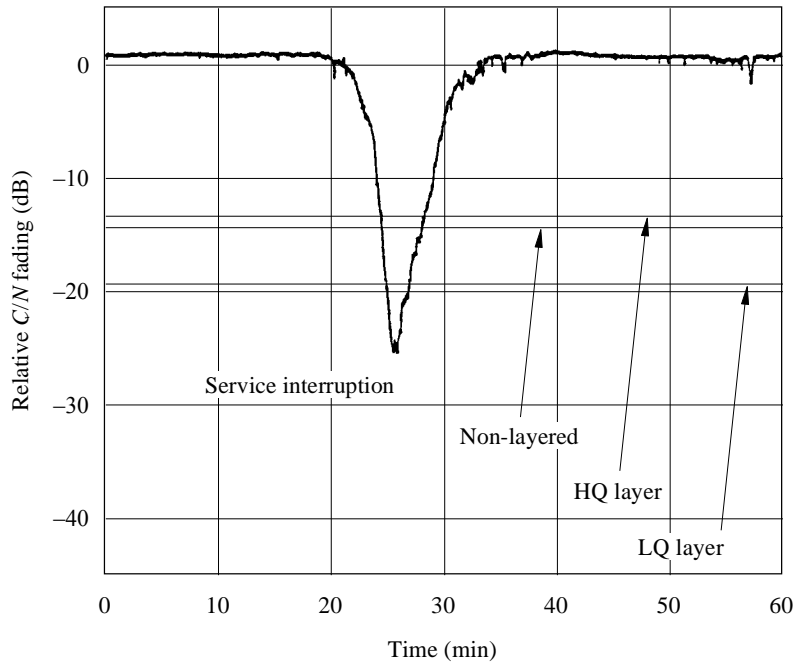

a) Case of a storm

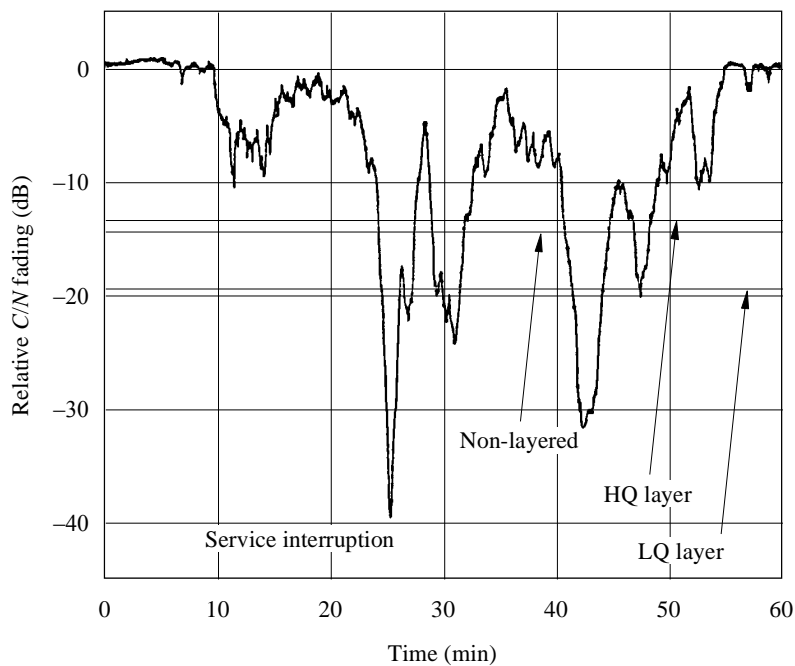

b) Case of a typhoon

Rap 2007-08

For the viewers of HDTV, for example, even a relatively short interruption of service can severely disturb an attractive and exciting scene. Therefore, although it is important to evaluate the service continuity due to the rain attenuation with cumulative time percentage, detailed rain fade profiles

are much more important when considering service availability. Digital broadcasting should bring excellent performance, far better than current FM television broadcasting.

It should be noted that the effectiveness of layered modulation depends largely on the available link budget margin for the high-quality (HQ) service. Layered modulation can significantly improve the service availability, accepting a lower quality level of service during high precipitation periods, if the HQ link budget margin is relatively small (e.g. 3-4 dB), i.e. for limited satellite transmit power and/or small home receive antennas. If the HQ link budget margin is rather large, say 10-15 dB, because high satellite e.i.r.p. and/or large home receive antennas are used, the improvement in service continuity by the second (and, if applicable, the third layer) is relatively small, because rain attenuation increases exponentially for small cumulative percentages of time.

4 Summary

The described methods are examples of how the service continuity could be increased by using a concept of layered modulation in conjunction with layered picture coding and layered channel coding. Other variants of this principal approach are presently under investigation. It can already be deduced, however, that by means of this technique the service continuity could be extended to, or even exceed, 99.9% of the worst-month in areas of moderate climate without the need for increasing the satellite transmit power, the service quality under severe attenuation conditions being reduced from high definition to normal or limited definition television. In countries characterized by high density (tropical) rainstorms, additional measures such as adaptive satellite e.i.r.p. control method (see Annex 2) might be required to reach such a high service continuity. Nominal high-quality sound service should be preserved even under severe fades and the sound should only fail after the failure of picture.

The concepts outlined in this Annex warrant further study. For example:

- Effects of detailed compensation by the layered modulation approach using the practical rainfall profile.
- Parameters for efficient service availability and the threshold C/N value for each layer.
- Effects of frequent strong rainfall in typhoons, etc. and of heavy continuous rain.
- Complexity of the demodulator and the decrease of efficiency of spectrum usage due to layered transmission.
- Development of stable demodulator in a low C/N environment, especially for synchronization.

References

- PALICOT, J. and VEILLARD, J. [1993a] Possible channel coding and modulation system for the satellite broadcasting of a high-definition signal. *Image Comm. J.*, Special Issue on "Advances in High-Definition Television", September.
- PALICOT, J. and VEILLARD, J. [1993b] Possible coding and modulation approaches to improve service availability for digital satellite broadcasting at 22 GHz. *IEEE Trans. Consumer Electron*, August.
- TSUZUKU, A., FUKUCHI, H., OHKAWA, M., OHUCHI, and MORIKAWA, H. [1993] Advanced satellite broadcasting experiment using Japan's R&D satellite COMETS. Proc. 23rd European Microwave Conference (EUMC'93), Madrid, Spain, 6-9 September, 110-112.

Annex 2

Satellite transmission experiment of live UHDTV (7 680 × 4 320 pixels) or Super Hi-Vision (SHV) pictures using WINDS

1 Introduction

Japan launched in 2008 an experimental satellite WINDS (Wideband InterNetworking engineering test and Demonstration Satellite), including an 18 GHz band mission, to develop high speed satellite communications. The bandwidth of the WINDS is 1 100 MHz (maximum). The output power is 280 W (maximum) and the e.i.r.p. is over 68 dBW. New high-data rate broadcasting services supporting UHDTV and three-dimensional representation are also a development goal in Japan. The satellite transmission experiment of live UHDTV (7 680 × 4 320 pixels) or Super Hi-Vision (SHV) pictures using WINDS was carried out in 2009. It was the world's first live relay broadcast of an SHV program using satellite.

2 Outline of satellite transmission of live UHDTV (7 680 × 4 320 pixels) or Super Hi-Vision (SHV)

The whole transmission system is outlined in Fig. 9 and major equipment is shown in Fig. 10. An SHV camera and a 22.2 ch microphone array were set up on the Sapporo TV tower at 90 m altitude. The original bit rate is 24 Gbit/s and 27.6 Mbit/s for the picture and sound, respectively. The original signal was compressed to 100 Mbit/s in total, and then IP transmitted in the optical fibre called "JGN2plus", which is a test bed provided by National Institute of Information and Communications Technology (NICT). The compressed SHV signal of 100 Mbit/s was multiplexed with the other two stored SHV programmes, 100 Mbit/s each, at NICT Kashima. Then the three SHV programmes, 300 Mbit/s in total, were uplinked to the satellite WINDS. The transmission parameters for the satellite WINDS are shown in Table 3. The wave from WINDS was received by a 2.4 m earth station antenna at NHK Science and Technology Research Laboratories (STRL).

The parameters for the satellite transmission experiment are given in Table 4. The modem used in this demonstration has a 300 MHz bandwidth. By exploiting the wide bandwidth, the maximum bit rate (TS rate) is 500 Mbit/s. The modulation scheme was QPSK or 8PSK. The roll-off factor can be selected from 0.1, 0.2 and 0.35. The error correcting code is the concatenated low density parity check (LDPC) and BCH coding.

The C/N vs BER characteristics via satellite WINDS is shown in Fig. 11. It can be mentioned from Fig. 11 that the characteristics are similar among the three roll-off factors. At the experiment, the receiving C/N was 20 dB, and a 10 dB and a 15 dB margins were obtained for 8PSK_{2/3} and QPSK_{3/4}, respectively.

In the demonstration, the decoded pictures were displayed on a 103 inch Plasma Display Panel (PDP), which has 7 680 × 4 320 pixels, at NHK STRL.

FIGURE 9

Outline of transmission system of UHDTV (7 680 × 4 320 pixels, SHV)

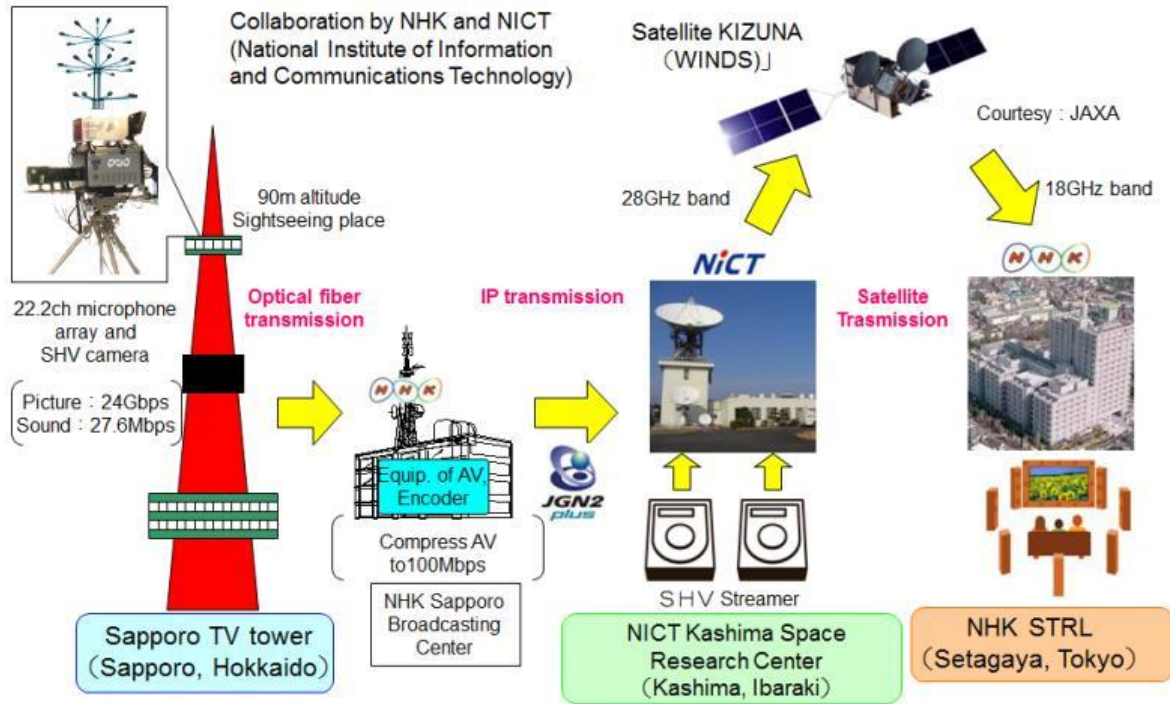

TABLE 3

Transmission parameters for the satellite WINDS

Uplink centre frequency	28.05 GHz
Downlink centre frequency	18.25 GHz
Bandwidth used	300 MHz
e.i.r.p. at the experiment	70 dBW
Diameter of earth station TX antenna	4.8 m
Diameter of earth station RX antenna	2.4 m

FIGURE 10

Equipment for the transmission system of UHDTV



SHV camera and 22.2ch microphone array on Sapporo TV tower

SHV encoder (Sapporo) and decoder (NHK STRL) (H.264, TS 100 Mbit/s)



Receiving antenna (2.4 m, NHK STRL)

Modulator (Kashima) and demodulator (NHK STRL)

Transmitted SHV picture from Sapporo on 103 inch PDP

TABLE 4

Parameters for the satellite transmission experiment

Modulation	QPSK/8PSK
Symbol rate	250 Mbaud/s
Bit rate capacity	370 Mbit/s (QPSK3/4) 500 Mbit/s (8PSK2/3)
Roll-off factor	0.1, 0.2, 0.35
Error correction	LDPC + BCH
Coding	AVC/H.264
Compressed bit rate of SHV	100 Mbit/s/programme
Number of SHV programmes	3
Multiplexing of SHV signals	Time division multiplex

FIGURE 11
C/N vs BER characteristics via satellite

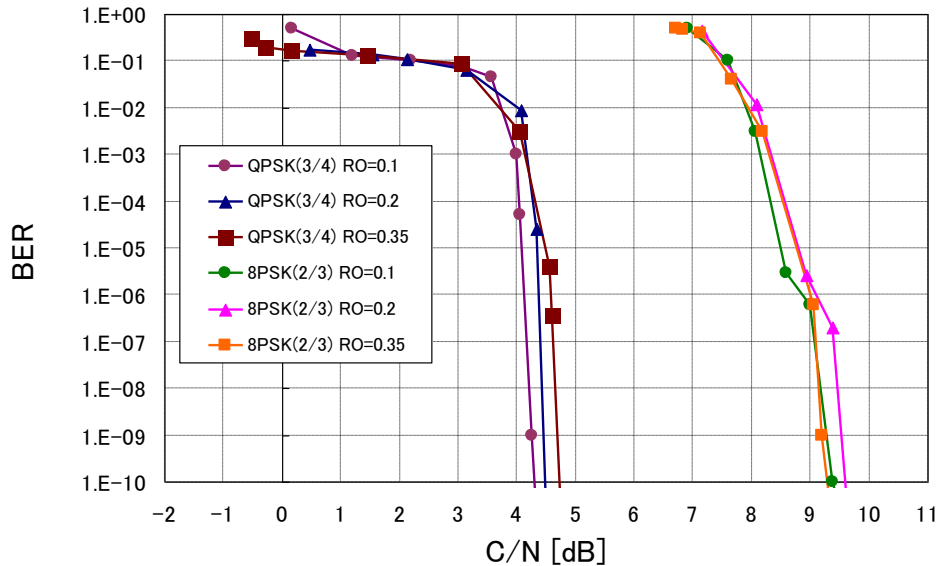

3 Summary

This Annex presents the results of satellite transmission experiment of live UHDTV (7 680 × 4 320 pixels, SHV) pictures using WINDS. The LDPC code and a modem with a wide bandwidth of 300 MHz were used. The three programmes of SHV, 100 Mbit/s each, were transmitted at the same time. This confirms the possibility of SHV broadcasting in the future using the 21 GHz band.

References

- SHOGEN, K. [2009] Super Hi-Vision Transmission Technologies and the Significance of WINDS Satellite Transmission Experiments. NHK STRL. Bulletin Broadcast Technology, Lecture 2, No. 36, 2009.4, <http://www.nhk.or.jp/strl/publica/bt/en/fe0036-2.pdf>.
- OYAMADA, K., OKABE, S., AOKI, K. and SUZUKI, Y. [January 2013] Progress of Transmission Technologies for UDTV, Proc. IEEE, Vol. 101, No. 1, pp. 154-168.

Annex 3

Bandwidth efficient coding and modulation schemes for wideband HDTV applications supported by satellite and cable networks

1 Introduction

HD-SAT [1] is a four-year research project (from 1992 to 1995) jointly funded by the participating partners and the European Commission (DG XIII) as part of the RACE II programme. HD-SAT has as its objective to study, develop and demonstrate the feasibility of a complete broadcasting chain

based on 30/20 GHz satellite transmission to potentially provide to the television end-user's home virtual studio quality HDTV, along with multilingual/multichannel sound. The HD-SAT "system", includes the studio to satellite uplink, the direct-to-home (DTH) satellite reception, as well as secondary distribution via terrestrial networks including cable and multipoint microwave distribution system (MMDS), as well as the currently developing integrated broadband communication networks (IBCNs). Figure 12 below gives the overall architecture of the HD-SAT system.

FIGURE 12
Overall HD-SAT system architecture

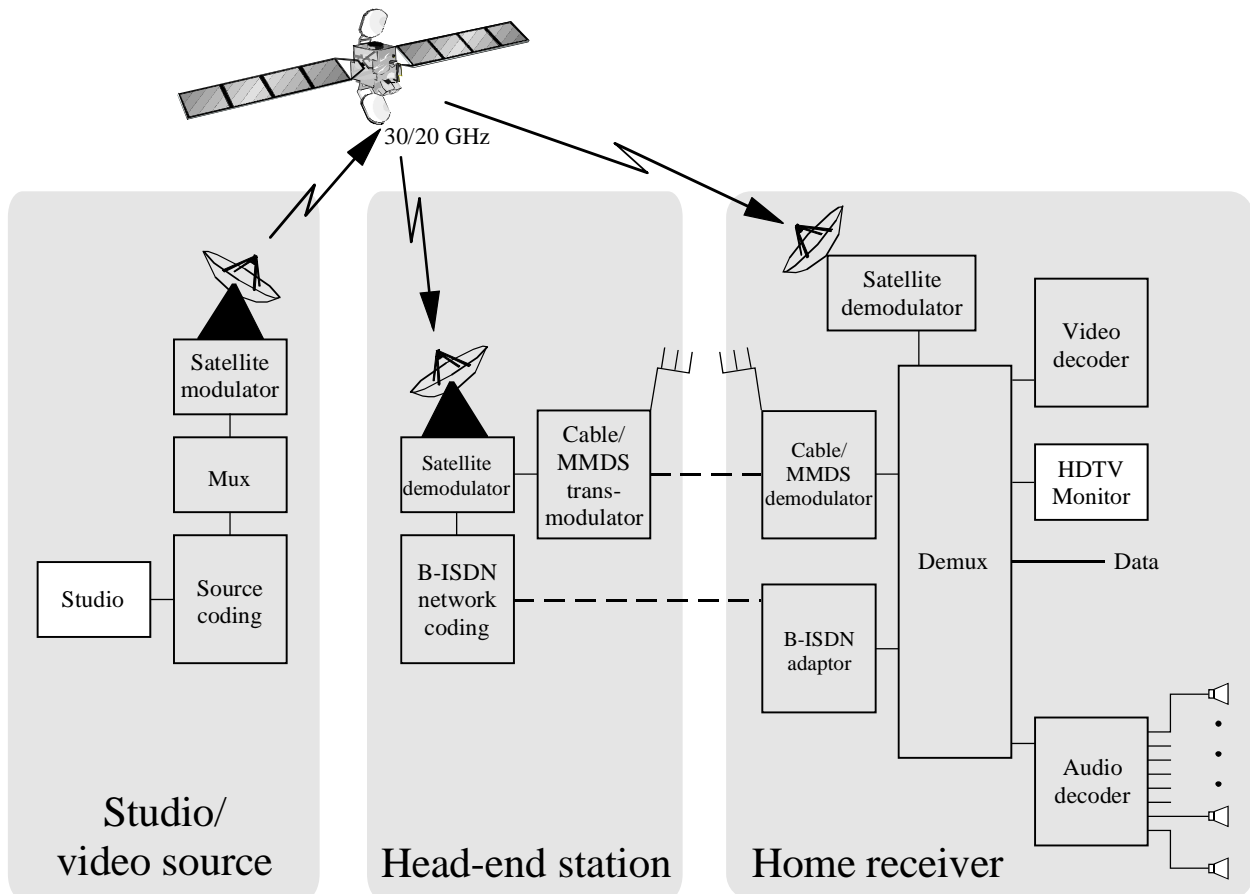

Rap 2007-12

A proposal for bandwidth efficient coding and modulation schemes for wideband HDTV applications supported by satellite and cable networks is given below, and contains the following main items:

- a summary of the basic HD-SAT service characterization;
- an introduction to graceful degradation in the Ka-band (30/20 GHz band) for service continuity;
- an example of a three-layer system;
- an introduction to the interworking aspects considered in the Project, and more particularly the "common receiver concept" and the "interoperability with cable networks".

2 Service characterization

Service requirements and characterizations within the HD-SAT project have been determined with user requirement studies including a comprehensive survey which was sent to European satellite operators, terrestrial broadcasters and cable network operators.

A summary of the basic HD-SAT service characterization is given below:

- service availability of 99.6% (of worst month);
- highest quality possible within HDTV format (virtual studio quality);
- European coverage;
- small (60-90 cm) DTH receiver antenna;
- full quality service to the end-user via cable and MMDS networks.

3 Service continuity – graceful degradation in the Ka-band

The use of the 20 GHz frequency band for satellite transmission must cope in an efficient way with the adverse propagation conditions in these bands, which are characterized by deep rain fades and atmospheric depolarization. A key issue is the service continuity, for which new solutions are implemented which involve layered channel modulation to allow for a “graceful degradation” under deteriorating atmospheric conditions.

Contrary to the gradual degradation observed in analogue systems, for digital TV it is possible to go from virtually error-free reception to complete loss of picture decoder operation over a range of less than 1 dB of C/N degradation (the brick-wall effect). By providing for the means of receiving lower quality pictures under deteriorating reception conditions, digital graceful degradation can allow for an increased service continuity.

The goal for a successful satellite modulation scheme is, using minimum satellite power and a small home receiver antenna size, to achieve service continuity for 99.6% of the worst-month within Europe.

The graceful degradation satellite modem for HD-SAT has been conceived using the concept of time-multiplex of modulation techniques offering a hierarchy of C/N values required for successful demodulation. In this way, as the propagation conditions deteriorate, the modulation layers requiring the higher C/N values are “lost”, while the more robust layers continue to be received. Synchronization of the modem is simplified by keeping the same symbol rate (27 MBd/s) for each of the modulation layers.

Figure 13 illustrates the modulation “frame” for a three-layer implementation.

FIGURE 13
Example of hierarchical channel coding

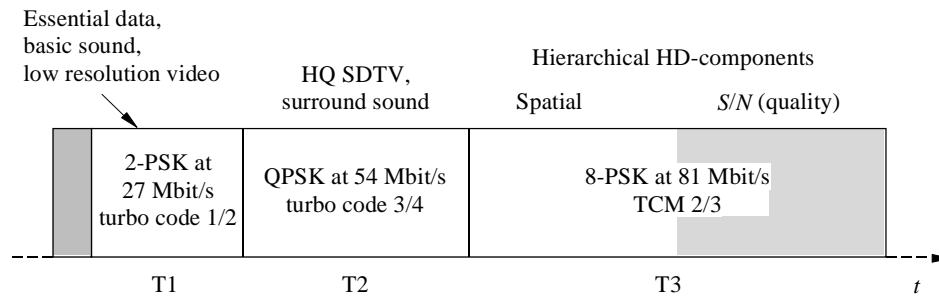

T1: turbo code 1/2

T2: turbo code 3/4 or "convolutional code and Reed-Solomon"

TCM: trellis coded modulation

Rap 2007-13

When choosing, for example, the ratio $T1:T2:T3 = 1:3:6$, the corresponding bit rates will be 2.7 Mbit/s for T1, 16.2 Mbit/s for T2 and 48.6 Mbit/s for T3, giving the total gross bit rate of 67.5 Mbit/s.

8-PSK modulation combined with trellis convolution coding is selected as an appropriate scheme for the highest spectral efficiency (but least "robust") of the HD-SAT modulation hierarchy. Lower level schemes include QPSK with turbo code or a classical scheme of convolutional code with concatenated Reed-Solomon, for an intermediate level of service, and 2-PSK for the low-level service fallback mode.

Turbo coding uses iterative processes in a hardware efficient implementation of code concatenation. It is particularly effective when applied to relatively low code rates. Results of turbo coding applied to QPSK within HD-SAT show a significant coding gain, a high degree of independence to roll-off combined with good transmission efficiency (by removing the need for an FEC outer code) within a non-linear satellite channel. Under these conditions the performance of the channel coding closely approaches the Shannon limit.

A modulation scheme allowing for approximately 12 dB of attenuation between the nominal clear sky operating point for HDTV and complete loss of service is proposed as a viable solution. Of this 12 dB, 9 dB is provided by the graceful degradation operation itself, with the remaining 3 dB coming from the operating point margin of a "nominal" home receiver antenna.

A graph of HD-SAT service versus received C/N is given in Fig. 14 to illustrate the graceful degradation operation and performance.

FIGURE 14
Hierarchical channel coding C/N performance

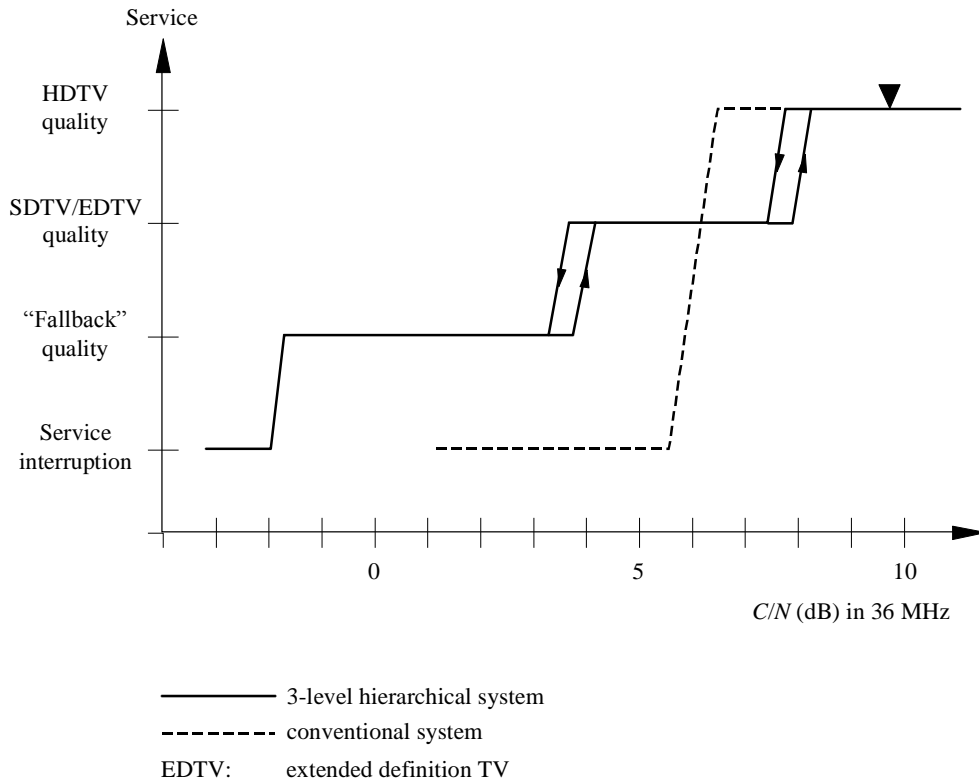

Rap 2007-14

4 Picture coding (MPEG-2) and attribution of the modulation layers

The HD-SAT system uses MPEG-2 coding (high profile at high level) and multiplexing, which amongst other functionalities offers the two following key features:

- spatial and SNR scalability;
- downward compatibility.

The codec definition and the function of the satellite graceful degradation modem are intimately related. The allocation of the appropriate components of the Codec to the modulation layer will define the HD-SAT services under graceful degradation.

The three-layer system below is chosen primarily for its comprehensive range of service availabilities over both moderate and severely degraded propagation conditions, as well as for its potential for interworking with other systems and media.

TABLE 5
Performances of layers

1st layer	Essential data, sound and limited definition image	e.g. 1.5 Mbit/s
2nd layer	“Good” quality SDTV sound and image and additional data	e.g. 10 Mbit/s
3rd layer	First sublayer: spatial hierarchical data complement to achieve HDTV quality	e.g. 15 Mbit/s
	Second sublayer: additional SNR scalable information complement to reach virtual studio quality HDTV	e.g. 20 Mbit/s

5 Interworking aspects

5.1 Common receiver concept

Interworking between media and television formats could be made economically feasible by the concept of the common receiver (see Fig. 15) which allows an end-user to receive programmes and services over a variety of media using a common demultiplexer, source decoder and display. For each media to be exploited, this common receiver uses the appropriate channel adapter/decoder which provides the common MPEG-2 transport stream format to the input of the multiplexer.

5.2 Interoperability with cable networks

The channel characteristics of a coaxial television cable network are very different from those of a satellite transponder. In particular, there is no need nor place for graceful degradation within the cable channel.

At the cable head-end, an adaptation of the HD-SAT MPEG-2 transport stream is required to optimize the use of the cable bandwidth. The base HD-SAT MPEG-2 transport stream necessarily contains some additional components for the service continuity fallback service which are not used in media implementation without graceful degradation.

For these purposes an MPEG-2 transmultiplexer is placed between the satellite demodulator and the cable modulator. The MPEG-2 transmultiplexer is effectively an MPEG-2 “switch” which accepts one (or several) MPEG-2 transport stream(s) on the inputs and delivers one (or several) MPEG-2 transport stream(s) on the output. The transmultiplexer is programmable to allow re-arrangement of the components and programmes which in this application means a filtering out of the unneeded components.

FIGURE 15
HD-SAT common receiver architecture

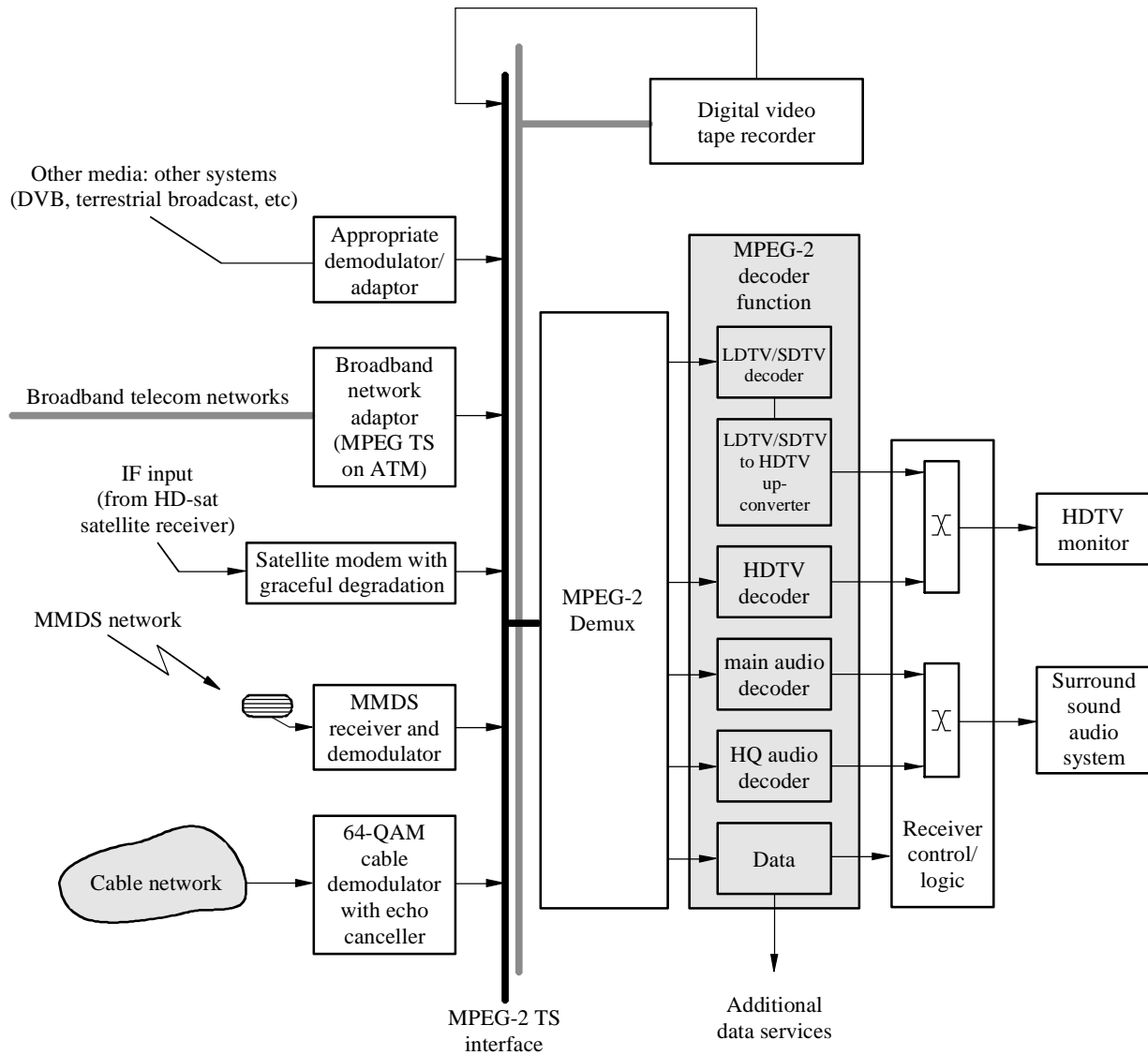

ATM: asynchronous transfer mode
DVB: digital video broadcasting

Rap 2007-15

The cable head-end station is configured in such a way that operation under graceful degradation modes is not used. In increasing the antenna size by a factor of about four relative to the DTH receiver, the HDTV service continuity is the same or better than the overall service continuity for the DTH receiver implementing graceful degradation. The resultant antenna size for the cable head-end would be on the order of 2.5 m. It is further noted that the additional increase in service availability which would be gained in using the graceful degradation modes under these larger antenna conditions is negligible.

Looking for maximum commonality with the system proposed by DVB, HD-SAT is developing 64-QAM transmission for cable, offering a capacity of 45 Mbit/s of channel data rate within 8 MHz.

6 Hardware system demonstration

A public demonstration of the entire HD-SAT broadcasting chain was held during the 1995 Montreux International Television Symposium and Technical Exhibition, 9-14 June 1995. In this paragraph, a reporting of the demonstration configuration, operation and results is provided. This demonstration was very successful in showing a concrete, working, and convincing implementation of what can be achieved in terms of a digital HDTV broadcasting chain based on the 30/20 GHz frequency band.

6.1 Overview of demonstration system configuration

In its generic system definition, HD-SAT has specified a system with three layers of modulation in the satellite channel, and a four-layer MPEG-2 TV encoding, including both spatial and SNR hierarchical coding for HDTV and additional LDTV. In a final implementation specification, a trade-off would be made to determine the subset of this functionality to be realised for an operational system.

The demonstration configuration has been defined as a subset of the generic implementation, which, beyond the pragmatic considerations of required demonstration hardware developments, may in any case prove to be sufficient. Nevertheless the demonstration configuration should not be assumed to correspond to a final specification of an operational system, i.e. in terms of the bit rates used, number of layers of coding and of transmission, the satellite power and coverage, etc.

It is noted that the demonstration event in Montreux was held jointly with a second RACE project, digital terrestrial television broadcasting (DTTB). The joint aspect of this demonstration allowed for a very significant demonstration of the possibilities of interworking between HD-SAT and other systems and media. However the scope of this section will be to concentrate on the 30/20 GHz satellite segment of HD-SAT.

A block diagram of the configuration of the HD-SAT broadcasting chains in the Montreux demonstration is given as Fig. 16 below.

The components of the TV programmes (video, sound) are coded using the MPEG-2 standard and then multiplexed into a single MPEG transport stream. This transport stream is delivered to the end users by the transmission chain, which is media-dependent. The interoperability function between the satellite and the terrestrial networks is accomplished in the cable head-end.

At the output of the transmission chain, the received transport stream is demultiplexed and the programme components are decoded. The use of the MPEG-2 transport stream specification supports the "common receiver" concept in which a single TV receiver and display can receive programmes over different transmission media.

6.2 Graceful degradation: demonstration configuration

6.2.1 Service continuity in the 30/20 GHz satellite frequency band

One of the key challenges for the HD-SAT project is to assure high service availability (continuity) in the Ka satellite frequency band which is well known for its rain attenuation characteristics. A layered satellite modulation scheme allows a high bit rate to be transmitted in the least robust layer (for clear sky conditions), with lower bit rates in the successively more robust layers. The given received service quality is determined by the highest layer which can be successfully demodulated. In this way during rain fades, the service does not fail abruptly, but stepwise. Although higher-level schemes have also been studied within HD-SAT, the configuration chosen for implementation at the Montreux demonstration is a two-level scheme, as illustrated in Fig. 17 below. Assuming a 3 dB margin in the link budget under clear sky conditions a dynamic range of approximately 12 dB is available before the total drop-out of the service occurs.

FIGURE 16
HD-SAT demonstration configuration

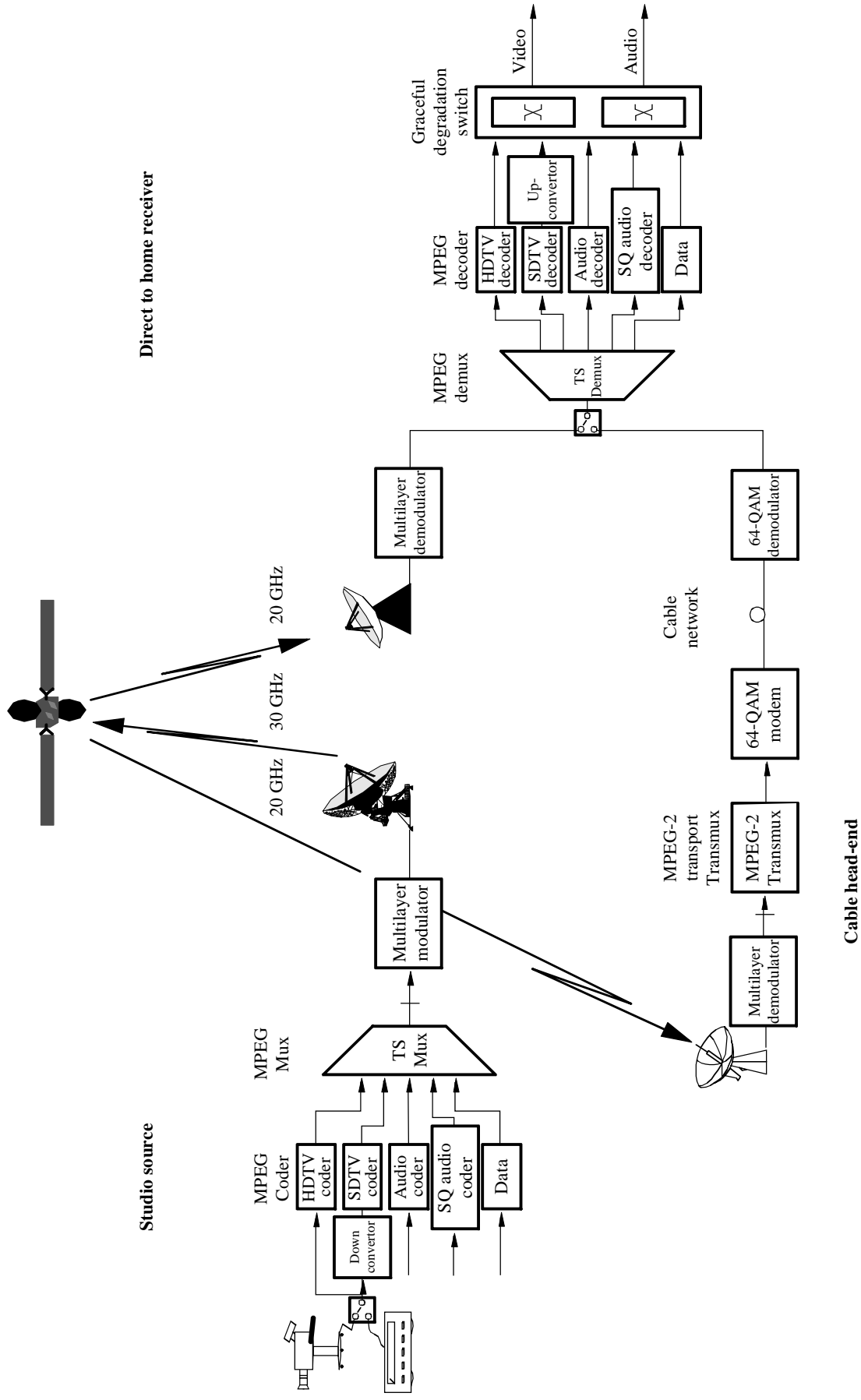
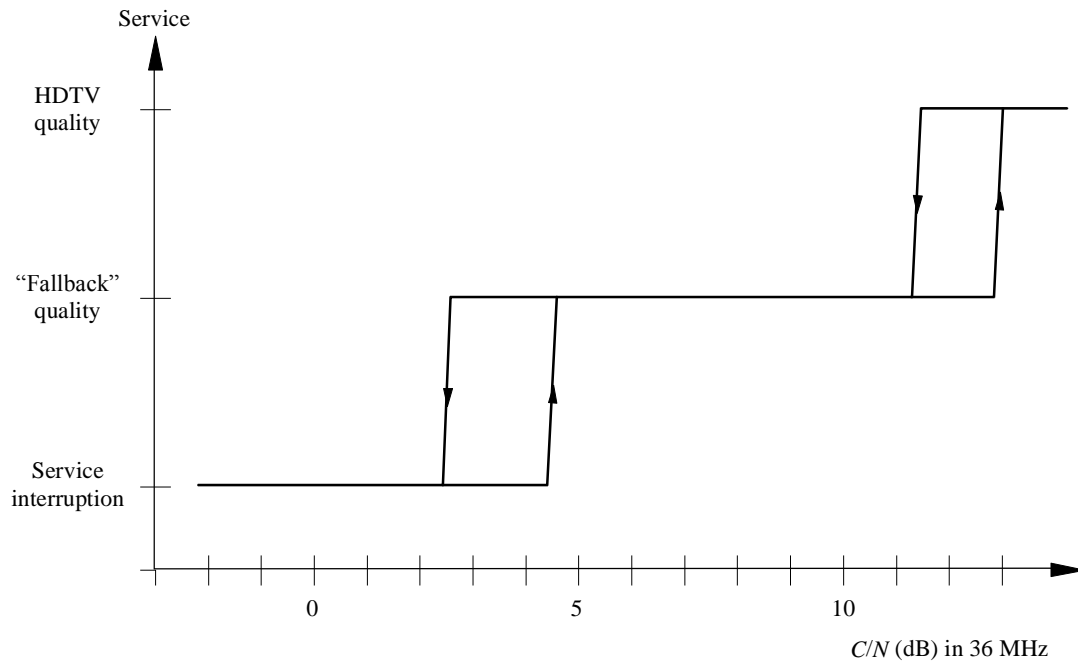

FIGURE 17
 Graceful degradation performance through a satellite 30/20 GHz channel
 (Montreux demonstration configuration)



Rap 2007-17

In this two-layer scheme, 8-PSK modulation combined with trellis convolutional coding is selected as an appropriate scheme for the layer with the higher spectral efficiency (but lowest robustness). QPSK with turbo coding, which has been the subject of extensive simulations proving its effectiveness, is used for the lower layer to assure the robust “fall-back” service.

Figure 18 illustrates the modulation 'frame' for the two-layer implementation.

FIGURE 18
 Two-level layered channel coding
 (Montreux demonstration configuration)

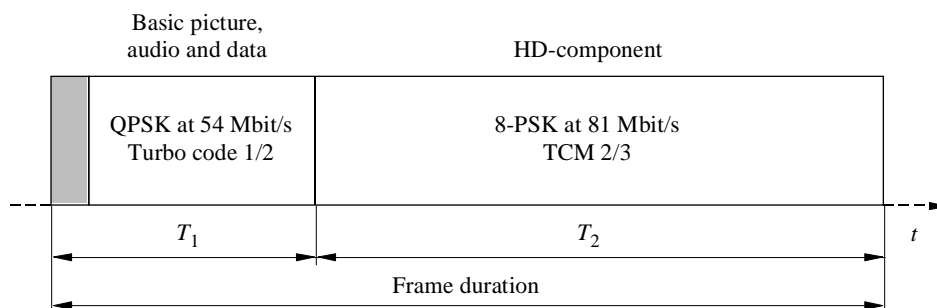

Rap 2007-18

A summary of the parameters of the demonstration configuration of the graceful degradation satellite modem is given below:

Satellite Transmission

- Ka-band (DFS-1 KOPERNIKUS): 29.58 GHz up-link, 1978 GHz down-link,
- 2-layer time-multiplexed graceful degradation modem,

- 27 Msymbol/s in 36 MHz bandwidth.
- QPSK modulation during T/6:
 - instantaneous bit-rate = 54 Mbit/s;
 - channel coding = turbo code (turbo3) with 1/2 rate;
 - useful instantaneous bit rate before coding = 27 Mbit/s.
- 8-PSK modulation during 5T/6:
 - instantaneous bit-rate = 81 Mbit/s,
 - channel coding = 2/3 rate trellis with concatenated Reed-Solomon,
 - useful instantaneous bit rate before coding = 54 Mbit/s.

MPEG-2 coding

The MPEG-2 codec functions for the demonstration configuration included:

- SDTV: main profile/main level 4:2:0,
- HDTV: main profile/high-1440 level 4:2:0,
- MPEG-1 stereo sound, and
- MPEG-2 layer II 5-channel surround sound,

all of which are multiplexed into a *single* MPEG-2 transport stream (TS) supporting satellite graceful degradation modes as well as full quality cable network interworking.

The details of the composition of the demonstration transport stream, including their respective allocations to the satellite graceful degradation modulation layer, is given in Table 6.

TABLE 6

Modulation layer	Content	Bit rates (net payload)
QPSK with turbo code	SDTV image with stereo sound	3.9 Mbit/s (video) 192 kbit/s (sound)
8-PSK with trellis convolutional code	HDTV image with 5-channel surround sound (MPEG-2, layer II)	39 Mbit/s (video) 384 kbit/s (sound)

6.3 Interworking with cable segment

The HD-SAT cable head-end receives the HD-SAT satellite signal and supplies the full quality HDTV service over a standard 8 MHz cable channel.

The primary cable head-end functionality demonstrated with the HD-SAT demonstration at the Montreux 1995 exhibition consisted of:

- the reception of an MPEG-2 TS as broadcast for DTH reception implementing graceful degradation,
- adaptation of this TS to a “pure” HDTV programme, and
- re-modulation of the lower bit rate stream using DVB-like 64-QAM modulation to feed an 8 MHz channel of a local cable network.

The common home receiver demodulates and decodes this cable channel in order to display the full quality HD-SAT HDTV signal.

These functions are represented schematically in Fig. 19

FIGURE 19
Schematic view of HD-SAT cable head-end interface

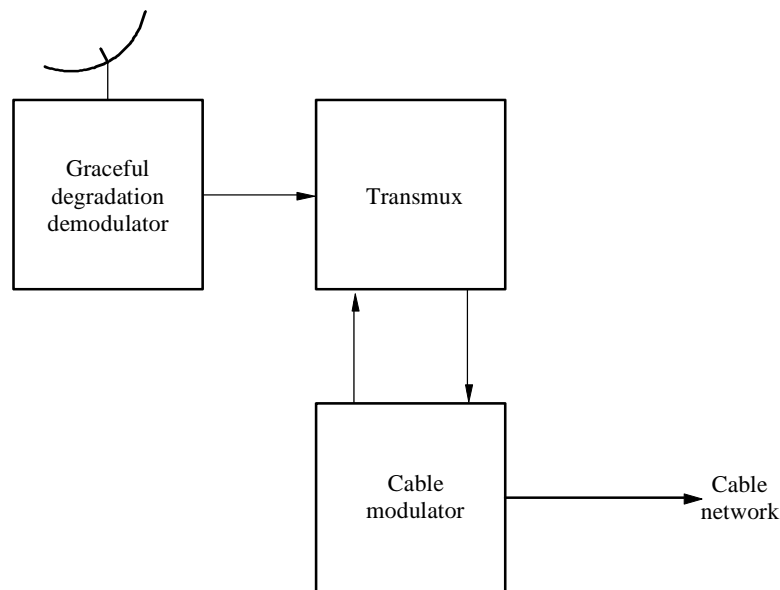

Rap 2007-19

6.3.1 Satellite reception at the cable head-end

The graceful degradation scheme implemented for HD-SAT allows the DTH end user to meet the service continuity requirements using a small receiving dish. A cable head-end station, which by definition will serve a certain number of cable subscribers does not need to have the same dish size requirements. Using a dish larger than intended for the individual end-user can result in an HDTV service reception continuity better than that provided using graceful degradation and the small antenna. Also, given the predicted and measured statistics of the propagation events in the 20 GHz frequency band, the service availability gained by including reception under graceful degradation conditions using this larger antenna would be negligible.

For these reasons, the satellite reception at the cable head-end for HD-SAT is implemented using an antenna of approximately 2 m diameter, for which the programme is assumed to be received in full HDTV quality with a service continuity meeting the requirements.

6.3.2 MPEG-2 transmultiplexer

For the cable channel, being bandwidth limited but not subject to variable transmission conditions, an implementation of graceful degradation is not needed. Thus for the demonstration configuration, the adaptation of the MPEG-2 TS consists of the removal of the SDTV components in the received satellite stream which are not required to generate the HDTV service.

This involves recognition and filtering of MPEG-2 packets based on Packet ID, management of the MPEG-2 time base and output bit-rate adaptation.

The demonstration version of the MPEG-2 transmultiplexer encompassed the following functionalities:

- packet filtering: removal of SDTV and stereo audio components,
- packet ID (PID) translation,
- output bit-rate adaptation,

- programme clock reference (PCR) jitter management.

The transmultiplexer function has been identified as having an important interworking role throughout the emerging digital television landscape.

6.3.3 Cable modulation

One of the objectives of the HD-SAT project is to align with and respect, to the extent possible, to new and existing standards for digital television within Europe.

The digital video broadcasting (DVB) project, which grew from the European launching group (ELG) for digital television, has defined a draft standard for cable segment using multi-level (nominally 64) QAM modulation within 8 MHz channels.

As a consequence of the definition of this standard, HD-SAT has chosen to re-orient its cable segment to be as close as possible to the DVB standard. In fact all aspects of the standard are respected, with an adaptation of the roll-off factor, which is halved with respect to DVB.

Specification for HD-SAT cable modem:

- Channel width: 8 MHz
- Modulation: 64-QAM
- Roll-off: 7.5% (sharper than DVB)
- Symbol rate: 7.5 MHz (higher than DVB)
- Interleaving: convolutional
- Channel coding: Reed-Solomon (204,188, $T = 8$)
- Shuffling: synchronous on 8 MPEG-2 packets ($(x^{15} + x^{14} + 1)$).

A sharper roll-off factor is necessary to increase the symbol rate within the constraints of an 8 MHz channel, so as to be able to carry the 45 Mbit/s payload required for the HD-SAT HDTV transport stream. The sharper roll-off implies an increased performance of the equalisation, which has been successfully realised.

Although the demonstration version of the HD-SAT cable modem was successful in pushing the roll-off performance higher than the nominal DVB specification, an alternative solution for the future, based on the current positive results, would be to adopt one of the higher levels of QAM modulation foreseen in the DVB specification (i.e. 128-QAM) in order to have a full quality HD-SAT service over a cable segment which is completely compliant to the DVB cable segment specification. The demonstration has also proven adequate cable echo-compensation with “blind” channel equalisation.

6.4 Interworking with other systems

Whereas the HD-SAT service concept (very high quality HDTV) and satellite frequency band used are both novel, the modular system concept and the adoption of MPEG-2 and DVB standards allows for wide openings towards interworking with other media and systems.

The joint nature of the demonstration in Montreux allowed for a very effective demonstration of this interworking, especially concerning the common receiver which was used to decode and display television signals from SDTV to HDTV, from stereo to 5-channel surround sound, over satellite, over a UHF terrestrial channel and over the Montreux cable network.

6.5 Demonstration operation

The HD-SAT broadcast chain functionality included:

- generation of an MPEG-2 coded transport stream of an HDTV signal with SDTV component for graceful degradation;
- the satellite up-link of the transport stream at 30 GHz to the KOPERNIKUS satellite;
- DTH satellite reception at 20 GHz with decoding and display of HDTV implementing graceful degradation (to SDTV quality);
- cable head-end reception with MPEG-2 transmultiplexing to adapt the transport stream to the cable media (removal of graceful degradation fallback components);
- cable reception of the full quality HDTV using the same decoder and display as for the DTH type of reception.

This very complex demonstration involved a very substantial amount of infrastructure, and equipment. In effect, the installation included a complete broadcasting environment, including a playout centre and continuity suite. The 20-seat presentation theatre was equipped with DHTV projection equipment and 5-channel surround sound, as well as four 16:9 SDTV monitors and an information/caption monitor. A presentation was given each hour during the five days that the exhibition was open, almost all the sessions were full (and most overflowing), so about 800 people saw the demonstration.

The entire demonstration was live, including the reconfigurations between the DTTB and HD-SAT operational modes of the MPEG-2 coders, multiplexers and transmission chains. This was well appreciated by the audience, who, through the resulting spontaneity, were very convinced and impressed by the live nature of the demonstration. The large audience and the very strong interest registered are conclusive proof of the success and high technical performance of this demonstration.

6.6 Consequences for an operational system

The satellite resource used for the demonstration was the 30/20 GHz experimental transponder of the DFS-1 KOPERNIKUS satellite of Deutsche Telekom. As this payload was not designed explicitly for a digital HDTV broadcast system, and considering that Montreux is nearly outside of the coverage range of this satellite, the satellite segment for the demonstration could not be completely representative of a commercial implementation of the HD-SAT service. In order to establish a link budget representative of an operational system, the TV receive only antenna was sized higher than would be used by a DTH user.

It is nonetheless possible to characterise the overall space segment and service offer corresponding to the satellite reception performance as shown in the Montreux demonstration. A representative example using the satellite power and coverage assumptions used in the HD-SAT system definition studies is summarized in Annex 5.

6.7 Conclusions

The HD-SAT project has demonstrated the feasibility of implementing a digital HDTV broadcast system based on the newly allocated 30/20 GHz satellite frequency band. The techniques used include both adoption of existing and evolving standards (i.e. MPEG-2, DVB), as well as innovative new techniques (satellite graceful degradation, satellite/cable interworking, interoperability with terrestrial broadcasting services). The result is a system which, while providing a new service (high quality digital HDTV) in a new satellite frequency band, remains compatible for interworking with other systems.

At this Montreux demonstration all the functions specified in the system architecture were demonstrated. The co-operation between HD-SAT and DTTB for this demonstration paved the way for the first European broadcast demonstration of digital MPEG-2 TV and HDTV programmes over satellite, cable and terrestrial channels.

The HD-SAT cable segment has shown how a cable modem based on the DVB standard, can be used to achieve high enough bit rates in an 8 MHz channel to provide the same very high quality digital HDTV.

The high quality, real-time MPEG-2 codec/multiplex and transmultiplexer implementations, examples of the prototype equipment developed to existing standards are items for which the HD-SAT prototypes are among the first full-scale implementations.

The innovative graceful degradation modem has proven by demonstration within a complete broadcast chain, that the 30/20 GHz satellite frequency band can be used to provide DTH delivery of high quality digital HDTV, using small satellite receive antennas and reasonable satellite power. The till now theoretical studies have thus been complemented by a working example, preparing the way for further development of operational systems.

References

- [1] The HD-SAT consortium is comprised of 12 European partners forming a complete team which includes broadcasters, research institutions, and industry: Alcatel espace – France (coordinating partner), Acatel Italia – Italy, Alenia Spazio – Italy, British Broadcasting Corporation Research and Development Dept. – United Kingdom, Cable management international Services (CMIS) – Ireland, Centre Commun d'Etudes de Télédiffusion et Télécommunications (CCETT) – France, Institut für Rundfunktechnik (IRT) – Germany, Northwest Labs. – Ireland, Radio Televisione Italiana (RAI) – Italy, Télédiffusion de France (TDF) – France, Thomson CSF – France, University of Salford – United Kingdom and the European Broadcasting union (sponsoring partner).

Additional sponsorship support to HD-SAT includes: Deutsche Telekom – Germany, Telespazio – Italy and Radiotelevision Eireann – Ireland.

Bibliography

- COMBAREL, L. and LAVAN, E. [June 1995] HD-SAT: HDTV satellite cable interworking aspects. 19th International Television Symposium, Montreux, Switzerland.
- COMBAREL, L. and OLIPHANT, A. [June 1995] The first complete demonstration of digital television broadcasting: The joint demonstration of RACE Projects HD-SAT and dTTb. 19th International Television Symposium, Montreux, Switzerland.
- COMBAREL, L. and OLIPHANT, A. [Summer 1995] Digital broadcasting demonstrations by HD-SAT and dTTb at Montreux '95. *EBU Tech. Rev.*
- COMBAREL, L., LAVAN, E., DOSCH, C. and PALICOT, J. [June 1995] HD-SAT modems for satellite broadcasting in the 20 GHz frequency band. International Conference on Consumer Electronics (ICCE '95).
- DOSCH, C. [Summer 1993] Digital broadcasting of studio quality HDTV by satellite in the 21 GHz frequency range and by coaxial cable networks. *EBU Tech. Rev.*
- DOSCH, C. [1995] Satellite broadcasting of high-quality digital HDTV in the 20 GHz frequency range and its inter-working with other media services. International Broadcasting Symposium (IBC '95), Tokyo, Japan, 13-15 November. Proc. IBC '95, Broadcasting and the multimedia age, 325-331.
- DOSCH, C. and LAVAN, E. [1998] Digital HDTV broadcasting by satellite and cable networks with commonality for terrestrial broadcasting. *European Trans. on Telecomm.*, 1.

DOSCH, C., COMBAREL, L., LAVAN, E. and PALICOT, J. [November 1995] HD-SAT modems for the satellite broadcasting in the 20 GHz frequency band. *IEE Trans. on Consumer Electron.*, Vol. 41, 991-999.

LAVAN, E. and COMBAREL, L. [September 1994] HD-SAT (RACE 2075): HDTV broadcasting over Ka-band satellite, cable and MMDS. International Broadcasting Symposium (IBC '94), Amsterdam, Netherlands.

ITU text

Doc. 10-11S/TEMP/3-E – HD-SAT contribution to the 21 November-2 December 1994 session of WP10-11S (Draft New Report), (Sub-WP S2), 23 November 1994.

Annex 4

Possible exploitation of the BSS 21.4-22.0 GHz bank for HDTV

1 Introduction

The RAI has undertaken within the HD-SAT Project [European Commission 1995] an in-depth study to develop a possible spectrum management strategy for the broadcasting of wide RF-band HDTV in the 21.4-22.0 GHz band.

Starting from the boundary conditions which must be identified in order to make the new service commercially attractive, this Annex discusses the adoption of parameters as independent as possible from the current technology. The proposed parameters, i.e. the orbit separation, the polarisation, the pfd and the quality objectives are investigated.

2 Orbital separation

It is evident that an optimisation of the whole orbital arc necessary to allocate all the necessary orbital positions greatly increases the possibility of an efficient use of the resources, as well as the possibility of coexistence between different satellite networks.

In particular, the minimum angular separation between two adjacent satellites serving the same area on the same frequency and polarisation is an essential factor.

The domestic receiver should not have too stringent G/T requirements, in terms of antenna dimensions and low noise amplifier (LNA) noise figure. A parabola (or an equivalent planar array) having a diameter not greater than 90 cm was identified as a reasonable antenna for HD-SAT applications. This is an acceptable starting point for design purposes: no harmful interference should be received with this antenna from satellites on adjacent orbital positions, possibly operating in the same service area using the same frequency and the same polarization.

Concerning the receiver noise figure, it must be noted that the possible improvements on the present values (about 2.5 dB) do not significantly improve the link budget, which is mainly influenced by the propagation attenuations, some order of magnitude greater. The LNA noise figure could then be neglected.

Neither fixed antenna technology nor antenna dimensions should be imposed, but a well-defined performance mask, providing the required protection only if the effective area of the antenna is

greater than a reference figure. Because the mask mainly affects the use of the orbit, the orbit separation represents the first “decision variable” to be used.

3 Polarisation

The second “decision variable” is the choice of the polarisation reference system to be used in the up-and down-link.

The factors to be considered in the choice of polarisation for BSS are described in Report ITU-R BO.814. In its conclusion, the Report suggests the adoption of circular polarisation, mainly due to difficulties arising in the alignment of the domestic receiving antenna and in cross-polar discrimination (XPD) performance of the satellite antennas when operating in linear polarisation.

Low cost domestic receivers for DTH reception in the FSS 11 GHz band with linear polarisation are widely used nowadays.

The effect of depolarisation induced by the atmosphere, under bad propagation conditions, increases rapidly with the frequency.

The choice of the polarisation reference system to be used in the up- and down-link has a great influence on the possibility of frequency reuse (the same channel can be used to transmit two different signals toward the same service area, using orthogonal polarisation planes). In particular, from the propagation model for Earth-satellite links based on long term statistics (see Recommendation ITU-R P.618) it appears that, in the 22 GHz band and for a 99.9% worst month time availability, it is possible to reduce the effect of wave depolarisation XPD_p due to adverse propagation conditions (rain and ice crystals) passing from about XPD_p value of 20 dB up to 35 dB in case of linear polarisation. It must be remembered that when XPD_p increases, the corresponding depolarisation effect is reduced.

The adoption of linear polarisation is recommended, due to the XPD improvement that can be obtained by the use of linear polarisation supported by the experience gained with low cost domestic receivers for DTH reception in the FSS 11 GHz band. Moreover, considering that the up-link will mainly operate in the 27.5-30 GHz band (apart from some cases in the 17.3-18.1 GHz band), where the propagation XPD is the dominant factor, it is mandatory to adopt the linear polarisation in the up-link as well in order to minimise the depolarisation effect.

4 Power flux-density (pfd)

The third “decision variable” is the pfd that the satellite system radiates. Limits to the pfd are usually introduced to solve particular interfering conditions such as:

- to protect satellite networks operating in the same band but in different Regions;
- to protect co-primary services (e.g. fixed terrestrial services operating in the same frequency band, in the same or in other Regions).

In the case of the 21.4-22.0 GHz band some observations should be made:

WARC-92 decided that after 1 April 2007 existing services (fixed service (FS)), (mobile service (MS)) in Regions 1 and 3 will only be authorised to operate in this frequency band provided they do not interfere with the BSS nor claim protection from it. The pfd limits are used only for interim procedures relating to operational BSS systems introduced before this date, according to RR Resolution 33 (Rev.WRC-97).

The pfd limits could also be introduced to protect terrestrial systems in Region 2, although no harmful interference is to be expected in that the total European BSS arc is limited to the minimum possible elevation angle of some 20° to avoid excessive propagation attenuation.

The maximum efficiency in terms of flexibility can be obtained only by a proper implementation of satellite systems having a certain level of uniformity in their key parameters. In particular, the network should be power-balanced. In other words, satellite systems should respect a reasonable pfd homogeneity, a lower limit as well as an upper limit need to be established.

5 Quality objectives and protection ratios

The fourth “decision variable” is represented by the maximum acceptable interference level, expressed in terms of reduction of the link budget.

Due to the binary structure of the information transmitted, the degradation is expressed as worsening of the system C/N performance and therefore as a reduction of the service availability.

In fact, in a digital system the interference has no visible effect on the displayed picture quality until the BER reaches the visibility threshold. The presence of an interference then results in a degradation of the system BER vs. C/N performance.

In order to be able to treat the interference as an equivalent C/N reduction (i.e. the interference acts as gaussian noise having the same power in the same receiving bandwidth), the interference level should not exceed certain limits. Generally, an interference which does not cause a C/N reduction greater than 2 or 3 dB is considered appropriate for being treated as noise-like.

It is worthwhile to mention that, depending on the modulation scheme of the affected carrier, the degradation produced by a given interference changes.

The relationship between C/N and C/I is not linear: during adverse propagation the C/N is reduced by the additional path attenuation, while C/I remains practically unchanged (both the useful and the interfering paths are affected by the same attenuation, at least for the angular separation offering a limited antenna pattern discrimination).

In the particular case of the HD-SAT project, the satellite network operates in an environment that is highly affected by the propagation phenomena. The use of a “graceful degradation” is then envisaged, through the adoption of transmission systems using the concept of “layered modulation”. In such an approach, the transmission of the video signal makes use of a time-multiplex of various modulation schemes which could permit, according to the HD-SAT studies, an absolute gain of about 12 dB with the reference to the clear sky C/N conditions, when passing from HDTV through EDTV, SDTV to the LDTV (MPEG-1 like) quality.

Assumed that this extra margin is completely used to mitigate adverse propagation conditions, the C/I characterising the system should correspond to the most delicate modulation scheme of the multiplex, i.e. to the one carrying the most valuable information stream.

The adoption of the reduction of the C/N in the worst atmospheric conditions as a “decision variable” (expressed as a percentage), i.e. a global $C/(N + I)$ degradation criteria, would represent a reasonable quality objective. For example a C/N degradation due to interference of some 5% or 10% seems to be an acceptable value.

6 Conclusion

In order to initiate the work on establishing suitable procedures for the usage of the 21.4-22.0 GHz BSS band, an in depth study was undertaken to determine the potential capacity of this band with possible ways of use. Two different ways have been studied in order to assure maximum availability of resources (antenna diameter, bandwidth, orbital positions, polarisation, pfd limits). Pre-determination of general technical parameters was kept to an absolute minimum, more technical studies need to be completed before discussing procedures to manage this band.

References

EUROPEAN COMMISSION [Mars 1995] HDTV-BSS frequency planning and planning strategies in the 21.4 GHz-22.0 GHz band. Deliverable No. 54, RACE 2075 (HD-SAT), Brussels, Belgium.

Annex 5

Mission scenario for European 20 GHz digital BSS (HDTV)

An example mission scenario that would introduce HDTV broadcasting services in Europe is constructed based on the use of existing or near-term technologies. The objective is to allow individual reception via end-user terminals of small antenna dimensions (from 0.6 m in climatic zone H to 0.9 m in climatic zone L), while providing service availability of 99.9% of the worst month. Assuming the use of the HD-SAT graceful degradation modem as described in Annex 3 and in § 2.1 of Annex 1, a link calculation leads to a minimum e.i.r.p. requirement of 55 dBW. Assumptions were made of the performance of satellite equipment which can be developed in short term:

- RF power of 75 W for a Ka band TWTA – two TWTAs can be used in a e.i.r.p. parallel configuration,
- maximum RF power of 3 000 W available on the satellite platform.

A trade-off analysis was performed on the coverage versus the number of channels offered to end-users in a specific zone. Considering the e.i.r.p. requirement, a wide coverage from a single orbital position is only possible as a composition of multiple spots. In this case, however, only a sub-band of the total bandwidth could be used within a given spot; at maximum one third of the total number of programmes are available locally (except for spill-over areas).

An upper limit for the total number of channels is set by the bandwidth of the total frequency band allocated to BSS services in Region 1: 21.4-22 GHz. Considering 36 MHz wide channels and taking a roll-off factor of 0.33 (i.e. 42 MHz channel spacing), a maximum of 28 programmes could be broadcast from a single orbital position using both polarisations. The 42 MHz spacing is chosen to limit the losses in the OMUX of the satellite output section.

In order to make this new BSS (HDTV) service attractive to the potential users, it was considered that a minimum of 20 channels is required per beam. For this reason a concept with single beam, rather than multiple spot, was taken for consideration. A typical contour plot based on a supranational coverage (Central Europe in the example) is shown in Fig. 20 below. (Of course, for any given region, additional coverage to supply additional channels is possible from different orbital positions.)

FIGURE 20

Example of a supranational satellite coverage in Central Europe
(The parameters refer to the gain of the satellite transmit antenna)

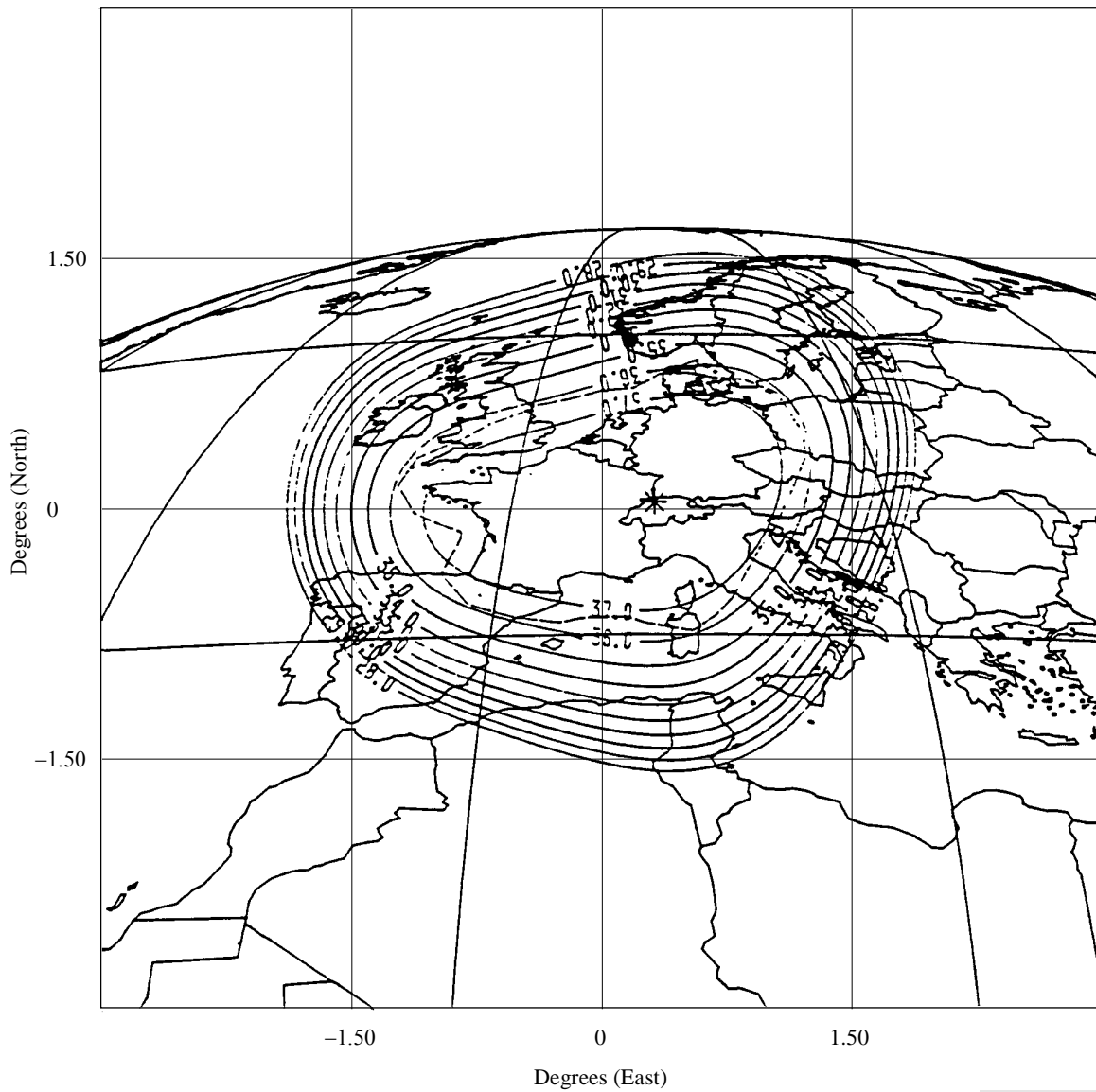

TABLE 7

Coverage	Supranational (e.g. France and Germany)	
Number of channels	20	
TWTA power (W)	two 75 TWTAs in parallel	
e.i.r.p. per channel (dBW)	55	
Platform power (W)	3 000 (RF)	
Ground receive antenna Ø (m)	0.6, climatic zone H	0.9, climatic zone L
Channel (and programme) bandwidth (MHz)	36	

Critical units requiring technological developments are identified as:

- OMUX which combines 10 channels of 150 W (2×75 W) each
- the satellite receive and transmit antennas.

Annex 6

Trial 4k (3 840 × 2 160 pixels) UHDTV broadcasting using COMS in the Republic of Korea

1 Introduction

The Republic of Korea launched in 2010 the satellite COMS (Communication, Ocean and Meteorological Satellite), including missions around the 20 GHz band, for experimental purposes. In 2013, ETRI and KTsylife performed the trial 4k UHDTV broadcasting using COMS.

2 Trial broadcasting of 4k UHDTV

A trial UHDTV broadcasting is planned around the year 2014 through a satellite around the 20 GHz band. Based on the plan, ETRI and KTsylife prepared to transmit 4k UHDTV using COMS and conducted the first test in 2012. The trial broadcasting was performed in two phases. In the first phase, H.264/AVC was used for video coding. After H.265/HEVC decoder was developed, it was used in the second phase. Figure 21 shows the configuration of test-bed for the trial 4k UHDTV broadcasting. The transmission parameters for the trial broadcasting using COMS are shown in Table 8.

FIGURE 21
Configuration of test-bed for the trial 4k UHD TV broadcasting

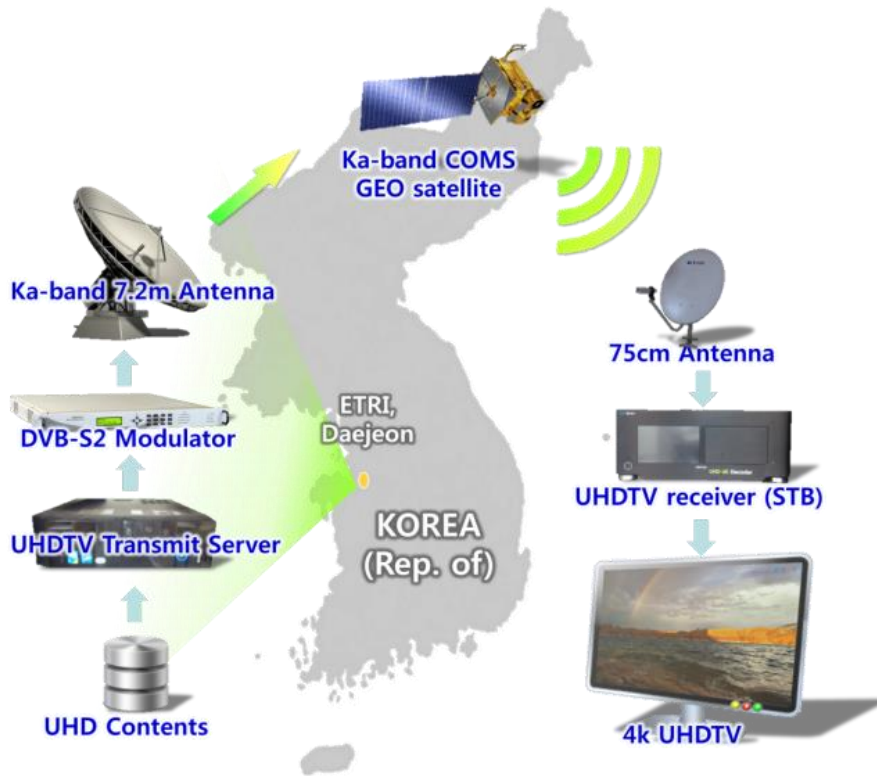

TABLE 8
Transmission parameters for the trial 4k UHD TV broadcasting

	Parameters	Features	Remarks
1	Uplink centre frequency	29.9 GHz	
2	Downlink centre frequency	20.1 GHz	
3	Channel bandwidth	36 MHz	
4	Earth station antenna size	Tx : 7.2 m Rx : 75 cm	
5	MODCOD	8PSK LDPC 2/3	DVB-S2 CCM
6	Video coding	H.264/AVC	2012.09~2013.01
		H.265/HEVC MP	2013.06~2013.09
7	Link availability	99.85%	

3 Summary

This Annex presents the trial 4k (3 840 × 2 160 pixels) UHD TV broadcasting in the Republic of Korea through COMS. The trial broadcasting based on the DVB-S2 and H.265/HEVC standards shows the possibility of commercial UHD TV broadcasting around the 20 GHz band.