

INFORME FINAL
UIT-D COMISIÓN DE ESTUDIO 2

CUESTIÓN 14-3/2

LA INFORMACIÓN Y
LAS TELECOMUNICACIONES
PARA LA CIBERSANIDAD

e

HEALTH

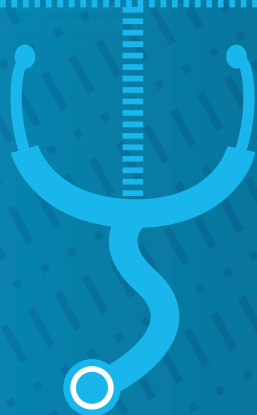

5.º PERIODO DE ESTUDIOS 2010-2014
Sector de Desarrollo de las Telecomunicaciones



CONTACTO

Sitio web: www.itu.int/ITU-D/study_groups
Librería electrónica de la UIT: www.itu.int/pub/D-STG/
Correo electrónico: devsg@itu.int
Teléfono: +41 22 730 5999

CUESTIÓN 14-3/2:

***La información y las telecomunicaciones/
TIC para la ciberseguridad***



Comisiones de Estudio del UIT-D

Para apoyar el programa de divulgación de conocimientos y creación de capacidades de la Oficina de Desarrollo de las Telecomunicaciones, las Comisiones de Estudio del UIT-D ayudan a los países a alcanzar sus objetivos de desarrollo. Las Comisiones de Estudio del UIT-D, que actúan de catalizador creando, compartiendo y aplicando conocimientos de las TIC para reducir la pobreza y propiciar el desarrollo socioeconómico, contribuyen a crear condiciones propicias para que los Estados Miembros utilicen los conocimientos y alcancen más fácilmente sus objetivos de desarrollo.

Plataforma de conocimientos

Los resultados aprobados en las Comisiones de Estudio del UIT-D, así como el material de referencia conexo, se utilizan para implementar políticas, estrategias, proyectos e iniciativas especiales en los 193 Estados Miembros de la UIT. Esas actividades también permiten aumentar el acervo de conocimientos compartidos entre los Miembros.

Centro de intercambio de información y divulgación de conocimientos

Los temas de interés colectivo se comparten en reuniones físicas, foros electrónicos y reuniones con participación a distancia en una atmósfera propicia al debate abierto y el intercambio de información.

Acervo de información

Los Informes, directrices, prácticas idóneas y Recomendaciones se elaboran a partir de las contribuciones sometidas por los miembros de los Grupos. La información se reúne en encuestas, contribuciones y estudios de casos, y se divulga para que los miembros la puedan consultar fácilmente con instrumentos de gestión de contenido y publicación web.

Comisión de Estudio 2

La CMDT-10 encargó a la Comisión de Estudio 2 que estudiara nueve Cuestiones en los ámbitos de desarrollo tecnológico y de infraestructura de la información y la comunicación, telecomunicaciones de emergencia y adaptación al cambio climático. La labor se concentró en métodos y planteamientos más adecuados y satisfactorios para la prestación de servicios en los ámbitos de planificación, desarrollo, aplicación, explotación, mantenimiento y sostenibilidad de servicios de telecomunicaciones/TIC que optimizan su valor para los usuarios. Esta labor se concentraba especialmente en las redes de banda ancha, las radiocomunicaciones y telecomunicaciones/TIC móviles para las zonas rurales y distantes, las necesidades de los países en desarrollo en materia de gestión del espectro, la utilización de las telecomunicaciones/TIC para mitigar las consecuencias del cambio climático en los países en desarrollo, las telecomunicaciones/TIC para la mitigación de catástrofes naturales y para operaciones de socorro, la realización de pruebas de conformidad y compatibilidad y las ciberaplicaciones, con enfoque y acento particulares en las aplicaciones basadas en las telecomunicaciones/TIC. También se estudió la aplicación de la tecnología de la información y la comunicación, teniendo en cuenta los resultados de los estudios realizados por el UIT-T y el UIT-R y las prioridades de los países en desarrollo.

La Comisión de Estudio 2, junto con la Comisión de Estudio 1 del UIT-R, también se ocupan de la Resolución 9 (Rev.CMDT-10) relativa a la "participación de los países, en particular los países en desarrollo, en la gestión del espectro".

En la elaboración del presente informe han participado muchos voluntarios, provenientes de diversas administraciones y empresas. Cualquier mención de empresas o productos concretos no implica en ningún caso un apoyo o recomendación por parte de la UIT.

Índice

	<i>Página</i>
1 Introducción.....	1
1.1 Estado de situación.....	1
1.2 Estudio de la Cuestión 14-3/2.....	2
1.3 Misión de la Cuestión 14-3/2.....	2
1.4 Métodos utilizados en el estudio de la Cuestión 14-3/2	3
1.5 Definición de país en desarrollo	3
1.6 Algunos aspectos importantes	4
1.6.1 Resumen de los principales problemas financieros y de asistencia sanitaria en los países en desarrollo.....	4
1.6.2 La brecha digital.....	4
1.6.3 Enfoque basado en la imitación.....	5
1.6.4 Cultura local y tradiciones.....	5
1.7 Un vistazo a la ciberseguridad y los países en desarrollo: cuestionario	5
2 Directrices para la implementación de la ciberseguridad en países en desarrollo	8
2.1 Hacia la normalización de la ciberseguridad.....	8
2.2 Normalización en materia de ciberseguridad – Experiencia de un país en desarrollo	10
2.2.1 Introducción.....	10
2.2.2 Inicio del proceso nacional de normalización.....	11
2.2.3 Análisis de las normas técnicas fundamentales.....	13
2.2.4 Normas sobre sistemas de información para la gestión hospitalaria (HMIS).....	15
2.2.5 Aspectos relacionados con el marco regulatorio y jurídico y mecanismos de cumplimiento	16
2.2.6 Mecanismos de cumplimiento y desafíos.....	17
2.3 Análisis de los factores económicos de la ciberseguridad	20
2.3.1 Factores económicos de la ciberseguridad	20
2.3.2 Qué, dónde, cuánto	21
2.3.3 Cómo evaluar los impactos económicos.....	22
2.3.4 Conclusión.....	23
2.4 Las TIC aplicadas a la mejora de la información y la rendición de cuentas sobre la salud de la mujer y el niño	25
3 De país en desarrollo a país en desarrollo – Lecciones aprendidas de la ejecución de prácticas idóneas.....	32
3.1 Ejemplos de prácticas idóneas de Estados Miembros de la C14-3/2	32
3.2 Apoyo entre países para la formación en ciberseguridad: 10 años de experiencia de la UIT en formación médica de corta duración	34
4 Conclusiones y recomendaciones	37
4.1 Recomendaciones de la C14-3/2-2013.....	38
4.2 Conjunto de Herramientas de la UIT y la OMS de la Estrategia Nacional de Cibersegud..	39

	<i>Página</i>
Annex I: Case Studies: Lessons Learned from e-Health Implementation	43
Annex II: Lessons Learned from e-Health Implementation: Knowledge.....	119
Annex III: Compendium of e-Health Projects for RMNCH Implemented in CoIA Countries	163
Annex IV: Composition of the Rapporteur Group for Question 14-3/2	169
Annex V: Glossary	170

Figuras y cuadros

Figura 1: Ejemplo de la encuesta de 2013	6
Figura 2: Las aplicaciones de la ciberseguridad y de las TIC benefician a las diversas partes interesadas del sector de la salud.....	28
Figure 3: Conjunto de herramientas para elaborar una estrategia nacional de ciberseguridad	40
Cuadro 1: Proyectos subvencionados actualmente por el Grupo de trabajo sobre innovación (2012 - 2014)	26
Cuadro 2: Innovaciones en ciberseguridad y las TIC del sistema de atención sanitaria continuada (“Continuum of Care”) de la OMS	29
Cuadro 3: Ejemplos de prácticas idóneas de Estados Miembros.....	32
Cuadro 4: Programa	36

CUESTIÓN 14-3/2

La información y las telecomunicaciones/ TIC para la ciberseguridad

1 Introducción

1.1 Estado de situación

La ciberseguridad es una de las áreas que actualmente goza de mayor crecimiento en el ámbito de la salud. La ciberseguridad es un sistema integrado de servicios de atención de salud que emplea tecnologías de la información y las telecomunicaciones como un sustituto de los contactos personales entre el médico y el paciente. Esto incluye numerosas aplicaciones tales como la telemedicina, los registros médicos electrónicos, las consultas médicas a distancia, las consultas médicas entre clínicas rurales y hospitales urbanos, etc. La ciberseguridad proporciona capacidades de transmisión, almacenamiento y recuperación de información médica en formato digital entre médicos, enfermeros, demás personal médico y pacientes con fines clínicos, educativos y administrativos, tanto a nivel local (su sitio de trabajo) como a distancia (sitios de trabajo remotos). En algunos países en desarrollo el número de teléfonos móviles ha superado al número de teléfonos fijos, y la red de telecomunicaciones móvil puede considerarse como una plataforma más atractiva para la introducción de servicios de ciberseguridad.

Una parte crucial del sistema de ciberseguridad es el ecosistema más amplio de productos y servicios que utiliza la banda ancha y proporciona los servicios innovadores que constituyen la ciberseguridad. Dentro de ese sistema, 'Internet de las cosas' es el concepto que aúna inteligencia y conectividad, y que es posible gracias a un poder de computación eficaz, de bajo costo y de bajo consumo. Este será el elemento principal de los productos electrónicos digitales más inteligentes que miden, gestionan y controlan las prestaciones de los equipos de electrónica de consumo y del ámbito sanitario. Los sensores personales, que en su conjunto configuran una red, pueden proporcionar información a los profesionales de la medicina sobre la salud de una persona gracias a la medición de parámetros tales como nivel de actividad, frecuencia cardíaca y nivel de glucosa.

La Organización Mundial de la Salud ha elaborado un compendio¹ de soluciones médicas y dispositivos para la ciberseguridad que son particularmente adecuados para entornos con recursos reducidos, en los que muchas personas sufren enfermedades innecesariamente debido a las dificultades de acceso a las tecnologías para la atención sanitaria. Además, en un informe del Banco Interamericano de Desarrollo² se han examinado las posibles aplicaciones de la salud móvil, con especial énfasis en las posibles oportunidades para América Latina.

A continuación se presentan algunos ejemplos:

- teléfonos inteligentes que habilitan aplicaciones de ciberseguridad al actuar como dispositivos principales en la recopilación, almacenamiento y transmisión de información sobre la salud del ciudadano. La creciente cantidad de datos recopilados de pacientes ha hecho que los profesionales sanitarios subrayen la importancia de la seguridad y la protección de los datos, de forma que los pacientes puedan confiar en que sus registros médicos están debidamente protegidos. En un informe de seguimiento tecnológico elaborado por el UIT-T en 2012³ se exponen algunos principios

¹ <http://who.int/ehealth/resources/compendium2012/en/index.html>

² <http://idbdocs.iadb.org/wsdocs/getdocument.aspx?docnum=1861959>

³ www.outgrid.eu/public/outgrid/download/homepage/T23010000170001PDFE.pdf

sobre la privacidad, la seguridad y la protección como parte de directrices sobre normativa e interoperabilidad en el contexto de la ciberseguridad;

- computación de bajo costo y energéticamente eficiente que permite utilizar baterías de larga duración y, por tanto, ser utilizada en servicios de supervisión fiables y económicos. Ello puede reducir las barreras de entrada a empresas que proporcionen nuevos productos y servicios para la ciberseguridad, y permitir a los prestadores de asistencia sanitaria de países en desarrollo aprovechar las ventajas de una amplia gama de servicios innovadores. También existen numerosos beneficios derivados de la reducción del consumo energético, pues no solo se reducen los costos, sino también la presión sobre las redes de suministro energético para las nuevas soluciones de ciberseguridad.

La ciberseguridad juega un papel muy importante en la asistencia sanitaria de los países en desarrollo, donde la aguda escasez de médicos, enfermeras y paramédicos es directamente proporcional a la enorme demanda insatisfecha de servicios sanitarios. Algunos países en desarrollo han puesto en marcha con éxito pequeños proyectos pilotos de telemedicina y desean continuar este tipo de iniciativas mediante la elaboración de un plan director de la ciberseguridad, tal como ha recomendado la Organización Mundial de la Salud en su Resolución WHA58.28, de mayo de 2005. En particular, se pretenden reducir las disparidades entre los servicios médicos de zonas rurales y urbanas, y prestar una especial atención a los países en desarrollo y a los países menos adelantados, incluidos los pequeños Estados insulares en desarrollo, los países en desarrollo sin litoral y los países con economías en transición. En lo sucesivo en este informe se utilizará el término 'países en desarrollo' para hacer referencia a dichos países.

1.2 Estudio de la Cuestión 14-3/2

La Cuestión 14-3/2 se centra en los aspectos siguientes:

- Tomar las medidas necesarias para aumentar la sensibilización de los responsables de la toma de decisiones, los reguladores, los operadores de telecomunicaciones, los donantes y los clientes sobre la función que desempeñan las tecnologías de la información y la comunicación en la mejora de la prestación de la asistencia sanitaria en los países en desarrollo;
- Fomentar la colaboración y el compromiso entre el sector de las telecomunicaciones y el sector sanitario en los países en desarrollo con vistas a maximizar la utilización de los limitados recursos disponibles en ambos sectores para la prestación de servicios ciber sanitarios;
- Continuar la divulgación de experiencias y de prácticas idóneas relativas al uso de las tecnologías de la información y las telecomunicaciones en la ciberseguridad en países en desarrollo;
- Fomentar la cooperación entre países en desarrollo y países desarrollados en el ámbito de los servicios y soluciones de la sanidad móvil;
- Promover el establecimiento de normas técnicas para aplicaciones de ciberseguridad conjuntamente con el UIT-T. En particular, la elaboración de directrices para los países en desarrollo sobre la mejor manera de utilizar esas normas;
- Elaboración y divulgación de normas técnicas de la UIT relacionadas con la ciberseguridad para los países en desarrollo;

Esta Cuestión fue inicialmente aprobada por la CMDT-98 y revisada por la CMDT-02, CMDT-06 y CMDT-10.

1.3 Misión de la Cuestión 14-3/2

La misión de la Cuestión 14-3/2 es la mejora de la salud al proporcionar a los Estados Miembros de la UIT información y orientaciones estratégicas sobre prácticas, políticas y normas eficaces en el ámbito de la ciberseguridad. Sus objetivos son los siguientes:

- Proporcionar evidencias e información oportunas y de alta calidad que ayuden a los órganos responsables de políticas y decisiones a nivel nacional e internacional sobre cómo mejorar las políticas, prácticas y gestión de los servicios de cibernidad;
- Aumentar la sensibilización y el compromiso de los órganos responsables de políticas y decisiones a nivel nacional e internacional y del sector privado con el fin de realizar inversiones y lograr avances en cibernidad;
- Recopilar, analizar y divulgar conocimientos relacionados con la cibernidad, incluidos los resultados de investigaciones que contribuyan significativamente a la mejora de la salud mediante las TIC; y
- Difundir mediante la publicación de informes sobre asuntos fundamentales en el ámbito de la investigación de la cibernidad y los logros prácticos alcanzados, que sirvan de referencia a los gobiernos y a los responsables políticos.

1.4 Métodos utilizados en el estudio de la Cuestión 14-3/2

Los orígenes de las aportaciones a la Cuestión 14-3/2 han sido y son los siguientes:

- Análisis de los estudios realizados por los miembros de la Cuestión 14-3/2;
- Realización de encuestas;
- Aportaciones de los Estados Miembros y de los Miembros del Sector, de expertos en aplicaciones de la cibernidad, etc.

Los resultados de la Cuestión 14-3/2 de la Comisión de Estudio 2 estarán disponibles en el sitio web del UIT-D.

Tal como se ha subrayado anteriormente, el objetivo estratégico de esta Cuestión es estimular la cooperación entre las comunidades de las telecomunicaciones/TIC y de la sanidad, entre países desarrollados y en desarrollo y entre países en desarrollo. También es previsible que los suministradores de equipos y los prestadores de servicios de los países desarrollados se beneficien de la experiencia obtenida a través de las aplicaciones de las telecomunicaciones/TIC para la cibernidad en países en desarrollo.

Antes de seguir adelante, es fundamental aclarar qué se considera país en desarrollo.

1.5 Definición de país en desarrollo

Un país en desarrollo⁴, también denominado país menos adelantado, es un país con un nivel de vida bajo, una base industrial insuficientemente desarrollada y un bajo valor del Índice de Desarrollo Humano en relación con otros países. Sin embargo, en el sistema de las Naciones Unidas no se ha establecido un convenio sobre la designación de países o zonas 'desarrolladas' y 'en desarrollo'. La práctica común en las Naciones Unidas es considerar que Japón en Asia, Canadá y los Estados Unidos de América en América del Norte, Australia y Nueva Zelandia, en Oceanía, y Europa son países o regiones 'desarrolladas'. En las estadísticas del comercio internacional también se considera que la Unión Aduanera del Sur de África es una región desarrollada e Israel un país desarrollado. Los países surgidos de la antigua Yugoslavia se consideran países desarrollados, y los países del este de Europa y de la Confederación de Estados Independientes no se incluyen como regiones desarrolladas ni en desarrollo.

⁴ Sección 1.5-7 de la contribución: M. Jordanova¹, L. Androuchko², 1Space Research & Technology Institute, Bulgarian Academy of Sciences, Bulgaria, Vice-Rapporteur 2, International University in Geneva, Dominic Foundation, Suiza, Relator, Cuestión 14 -3/2: La información y las telecomunicaciones para la cibernidad.

El Fondo Monetario Internacional (FMI) utiliza un sistema de clasificación flexible que considera (1) los ingresos per cápita, (2) la diversificación de las exportaciones, y por tanto los exportadores de petróleo con un PIB per cápita elevado no entrarían en la clasificación de avanzados porque aproximadamente el 70% de sus exportaciones son de petróleo, y (3) grado de integración en el sistema financiero mundial.

El Banco Mundial clasifica los países en cuatro grupos en función de sus ingresos. La clasificación se revisa el 1 de julio de cada año. El 1 de julio de 2011, las economías se dividían en función de su Ingreso Nacional Bruto (INB) de la forma siguiente:

- Países con ingreso bajo, con un INB per cápita de 1.026 dólares de los EE.UU. o menos;
- Países con ingreso mediano bajo, con un INB per cápita entre 1.026 y 4.036 dólares de los EE.UU.;
- Países con ingreso mediano alto, con un INB per cápita entre 4.036 y 12.476 dólares de los EE.UU., y
- Países con ingreso alto, con un INB per cápita superior a 12.476 dólares de los EE.UU.

El Banco Mundial clasifica a todos los países con ingresos bajos y medios como países en desarrollo, pero señala que “El término se usa por razones de conveniencia; no se pretende implicar que todas las economías en dicho grupo estén experimentando un desarrollo similar o que otras economías hayan llegado a una etapa preferencial o final de desarrollo. La clasificación según los ingresos no refleja necesariamente el estado de desarrollo.”

La información anterior es importante y debe recordarse ya que el concepto de apoyo a los países en desarrollo es el fundamental de la Cuestión 14-3/2 y de sus informes, tanto el preliminar como el final.

1.6 Algunos aspectos importantes

Estos aspectos deben tenerse en consideración siempre que se debata sobre la implementación de la cibernidad ya que pueden tanto dificultar como conformar el desarrollo de la cibernidad y su aplicación general.

1.6.1 *Resumen de los principales problemas financieros y de asistencia sanitaria en los países en desarrollo*

- La carga que suponen las enfermedades – diferente de la que suponen en las regiones desarrolladas;
- Población – más joven y con un crecimiento más rápido en comparación con las regiones desarrolladas;
- Servicios médicos – deficientes debido a la falta de facultades de medicina y de especialistas [1];
- Gasto en asistencia sanitaria – varias veces menor.

1.6.2 *La brecha digital*

La brecha digital es uno de los principales problemas para quienes planifican o intentan poner en marcha servicios de cibernidad en los países en desarrollo.

¿Qué es la brecha digital? El término se introdujo en la década de 1990 [2] y hace referencia a la diferencia existente entre los que tienen acceso y capacidad de utilizar las tecnologías de la información y la comunicación y los que no la tienen.

Los motivos de la brecha son numerosos, la pobreza en primer lugar, pero también la educación, el analfabetismo, la edad, el género, la cultura, el contacto con las TIC, la ubicación geográfica, la infraestructura, la conectividad, la anchura de banda y los costos de las telecomunicaciones. La brecha digital no sólo existe entre países desarrollados y en desarrollo, sino también dentro de los países.

La brecha digital se ha considerado un obstáculo para la puesta en marcha de la cibernidad en el mundo en desarrollo y en las zonas rurales del mundo desarrollado. Aunque se ha hablado mucho de la brecha digital, las expectativas eran que la brecha digital se reduciría con la mejora de las infraestructuras y la conectividad, la disponibilidad de anchura de banda adicional, la reducción de los costos de la tecnología y las comunicaciones y el uso creciente de los teléfonos móviles. Todo ello ha ocurrido en mayor o menor grado en gran parte del mundo en desarrollo.

En un excelente artículo, M. Mars [3] ha señalado que la brecha digital entre países desarrollados y en desarrollo no se ha reducido en los últimos diez años y plantea la cuestión de si en algún momento se reducirá. Teóricamente debería ocurrir, pero en la práctica es poco probable que ocurra conforme evoluciona la tecnología. Las conclusiones de los expertos sobre cuando se estrechará la brecha digital entre los países desarrollados y los países en desarrollo no son alentadoras.

Por todo ello, las actividades sobre cibernidad en los países en desarrollo deberían estar basadas en una comprensión realista de la brecha digital, sus implicaciones y los factores que la gobiernan.

1.6.3 Enfoque basado en la imitación

En las últimas dos décadas se ha asistido al fracaso de miles de proyectos de telemedicina y cibernidad. Incluso soluciones bien elaboradas y que están en funcionamiento en países desarrollados no han funcionado y han fracasado cuando se han puesto en marcha en regiones en desarrollo.

Es más que evidente que un enfoque basado en la imitación no es la mejor forma de lograr un desarrollo generalizado de la cibernidad. Soluciones muy utilizadas en países desarrollados no siempre son las que buscan o necesitan desesperadamente los países en desarrollo.

1.6.4 Cultura local y tradiciones

La falta de respeto, o incluso peor, la ignorancia negligente sobre las tradiciones y las referencias culturales locales pueden arruinar el proyecto de negocio de cibernidad más cuidadosamente preparado.

La aceptación cultural de cada una de las iniciativas de cibernidad en zonas en desarrollo es una condición *sine qua non*.

1.7 Un vistazo a la cibernidad y los países en desarrollo: cuestionario

¿Cuál es la situación actual de aplicación de la cibernidad en los países en desarrollo? Anualmente se publican miles de documentos, informes y presentaciones. Cada uno de ellos proporciona una parte de información sobre la aplicación de la cibernidad en una región, un país o una comunidad. Uno de los cuestionarios más amplios realizados en los últimos años es el del Observatorio Mundial de CiberSalud de la OMS, que resume los resultados de dos encuestas, una realizada en 2005 y otra en 2009.

La aplicación, aceptación y conocimiento de la cibernidad ha evolucionado desde al año 2009. Por ese motivo, los miembros de la Cuestión 14-3/2 decidieron realizar una encuesta a principios de 2013. La encuesta tiene forma de cuestionario y está disponible en <https://www.surveymonkey.com/s/KSZTVMT>. El cuestionario se centró en lo siguiente:

- la cibernidad en zonas en desarrollo y
- la opinión de los representantes de los países en desarrollo sobre cómo creen que la UIT, y en particular la Cuestión 14-3/2, puede contribuir a una aplicación más amplia de la cibernidad en sus respectivas regiones.

Se contactó con los coordinadores nacionales para la UIT y se les solicitó que participaran proporcionando información sobre sus respectivos países.

El cuestionario fue elaborado en colaboración con profesionales de la cibernidad miembros de la Cuestión 14-3/2 y con el apoyo de psicólogos y expertos en ética.

Actualmente han respondido más de 20 países y la recopilación de datos sigue en curso. Los resultados revelan lo siguiente:

- el 47% de las respuestas señalan la ausencia de una estrategia nacional de ciberseguridad;
- en los países en los que existe esa estrategia, su ejecución es parcial en el 90% de los casos;
- las herramientas y servicios de ciberseguridad más desarrollados y que están en funcionamiento son los registros nacionales de medicamentos, los sistemas de información de hospitales y los directorios de profesionales e instituciones sanitarias. Se señalan como prácticamente “no desarrolladas” las aplicaciones sobre telepsiquiatría, teleradiología, televigilancia domiciliar y supervisión de enfermedades crónicas.

La encuesta también ha reflejado problemas en aspectos de terminología. Los resultados han mostrado que la UIT podría ofrecer asesoramiento y/o ejemplos de prácticas idóneas o de prototipos genéricos para su adaptación a países en desarrollo. Los servicios que mejor podrían adaptarse a las necesidades de dichos países son:

- asesoramiento sobre normas y estándares de ciberseguridad;
- plan director de ciberseguridad;
- asesoramiento sobre desarrollo de recursos humanos para ciberseguridad;
- asesoramiento sobre programas de ciberaprendizaje en asistencia sanitaria, enfermería, odontología y psicología clínica;
- asesoramiento sobre políticas y estrategias de ciberseguridad;
- asesoramiento sobre métodos de supervisión y evaluación de servicios de ciberseguridad;
- información sobre prácticas idóneas/eficaces en ciberseguridad;
- información sobre tendencias y desarrollos en ciberseguridad (Figura 1).
- la encuesta se mantuvo en línea hasta mediados de 2013. La Cuestión 14-3/2 hizo cuanto estuvo a su alcance para recopilar todas las respuestas del máximo número de países en desarrollo.

Figura 1: Ejemplo de la encuesta de 2013

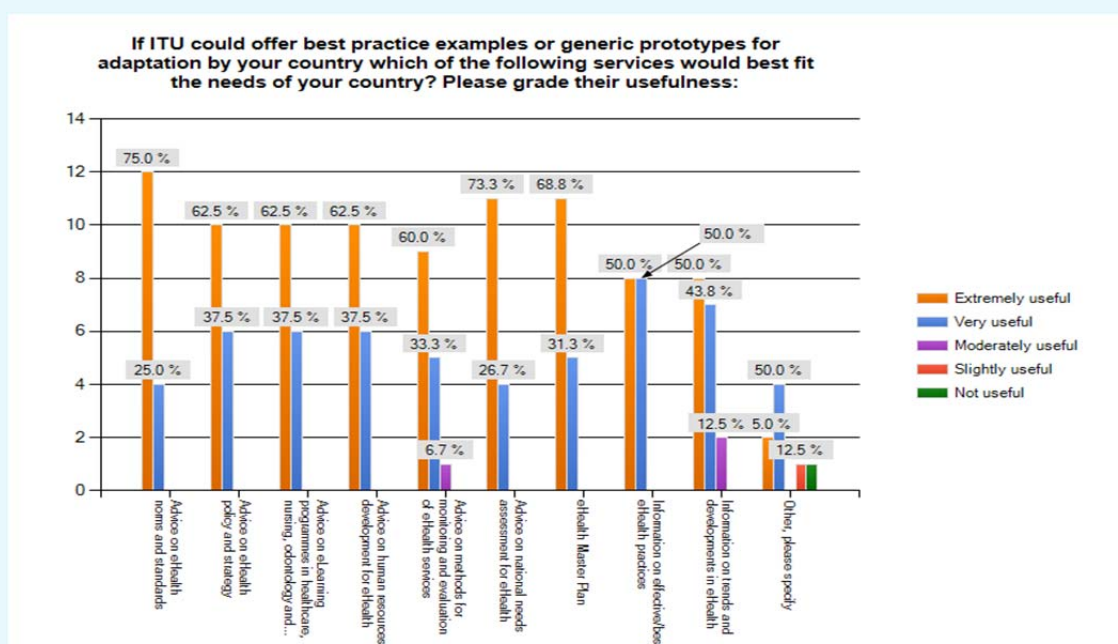

Referencias

- [1] JB Eastwood, RE Conroy, S Naicker, PA West, RC Tutt, J Plange-Rhule, Loss of health professionals from sub-Saharan Africa: the pivotal role of the UK. *The Lancet*, Volume 365, Issue 9474, 28 Mayo-3 Junio de 2005, pp. 1893–1900.
- [2] V. E. Eubanks "Trapped in the digital divide: the distributive paradigm in community informatics," *The Journal of Community Informatics*, vol. 3, pp. 1-12, 2007.
- [3] M. Mars, The Digital Divide: Still a Reality? In M. Jordanova and F. Lievens (Eds.) *Global telemedicine and eHealth Updates: Knowledge Resources*, Vol. 6, Publ. ISfTeH, Luxemburgo, 2013, pp. 277-280.

2 Directrices para la implementación de la ciberseguridad en países en desarrollo

2.1 Hacia la normalización de la ciberseguridad

⁵ La prestación de una asistencia sanitaria eficaz y asequible es actualmente un desafío para todos los países, con independencia de que se trate de países desarrollados o en desarrollo. La industria de la información y las comunicaciones tiene la oportunidad de contribuir sustancialmente a la prestación de la asistencia sanitaria en su conjunto. No hay dudas de que la introducción de servicios de ciberseguridad será beneficiosa en todos los países, en particular en países en desarrollo donde no existen recursos para mejorar sus sistemas de sanitarios mediante el enfoque clásico de aumentar el personal médico y los hospitales.

Como consecuencia de los esfuerzos de la UIT, en la Primera Conferencia Mundial de Desarrollo de las Telecomunicaciones, celebrada en marzo de 1994, se presentó y debatió por vez primera sobre la telemedicina en países en desarrollo. La Conferencia aprobó la Cuestión 6 (que en 1998 fue reenumerada como Cuestión 14) sobre telemedicina, que se asignó a la Comisión de Estudio 2 del Sector del Desarrollo de la UIT. De conformidad con las decisiones de dicha Conferencia, la UIT ha realizado diversas actividades relacionadas con el estudio de los potenciales beneficios de las aplicaciones de la ciberseguridad en el sector de la asistencia sanitaria de países en desarrollo y demostraciones de dichas aplicaciones en proyectos pilotos de ciberseguridad/telemedicina puestos en marcha en determinados países.

Posteriormente se celebró en Portugal el Primer Simposio Mundial de Telemedicina para Países en Desarrollo, del 30 de junio al 4 de julio de 1997. El Simposio fue una iniciativa de la UIT y contó con la amable invitación de la Administración portuguesa de telecomunicaciones a través del Instituto de Comunicaciones de Portugal. Al mismo asistieron más de 57 países y en muchos casos fue la primera vez en que se sentaron juntos especialistas de telecomunicaciones y médicos del mismo país. El Simposio fue la primera oportunidad para que países en desarrollo se familiarizaran con demostraciones de telemedicina, que discutieran con expertos de la salud y las telecomunicaciones e identificaran diferentes posibilidades y aplicaciones prácticas de la telemedicina en sus propios países.

La Organización Mundial de la Salud reconoció oficialmente la ciberseguridad/cibersalud en la quincuagésima octava reunión de la Asamblea Mundial de la Salud celebrada en mayo de 2005, donde aprobó la Resolución WHA 58.28 que estableció la Estrategia de Cibersalud de la OMS.

Como es habitual en el caso de ideas innovadoras, existen numerosos obstáculos, desde la resistencia a adoptar una nueva forma de prestación del servicio por parte del personal médico de países desarrollados hasta la falta de conocimientos sobre la ciberseguridad de los profesionales y la administración médica en los países en desarrollo.

Existe otro importante obstáculo que afecta tanto a países desarrollados como en desarrollo, a saber, la normalización en el ámbito de la ciberseguridad, una cuestión sumamente compleja. Pese a la enorme cantidad de dinero y recursos humanos dedicados, el resultado hasta la fecha ha sido bastante pobre, en particular para los intereses de los países en desarrollo. Éstos requieren una atención especial para satisfacer sus necesidades dada la situación de sus redes fijas y móviles. Las soluciones de las TIC para los servicios sanitarios y la ciberseguridad, incluida la sanidad móvil, han tenido un gran desarrollo particularmente en el último decenio. Sin embargo, las soluciones son aún, con demasiada frecuencia,

⁵ Contribución: L. Androuchko¹, I. Nakajima², M. Jordanova³, ¹International University in Geneva, Dominic Foundation, Switzerland, Rapporteur, Question 14 -3/2- Telecommunication in Healthcare; ²Tokai University, School of Medicine, Japan, Vice-Rapporteur; ³ Instituto de Tecnología e Investigación Espacial, Academia Búlgara de las Ciencias, Bulgaria, Vicerrelator.

pequeñas aplicaciones aisladas incapaces de comunicarse con otros sistemas sanitarios y/o compartir información entre tecnologías y ámbitos geográficos diversos.

Las barreras para el crecimiento de sistemas de pequeño tamaño en países en desarrollo impiden que puedan ser utilizados para una gran base de pacientes y prestadores de asistencia sanitaria. Los responsables de la toma de decisiones no son necesariamente capaces de evaluar la verdadera situación sanitaria, lo cual impide que se realice una planificación, respuesta y formulación política integral.

El Sector de Normalización de la UIT coordina la normalización técnica de los sistemas multimedia y las capacidades para las aplicaciones de la ciberseguridad. El Sector ha publicado recientemente un nuevo informe de seguimiento tecnológico⁶ que analiza el futuro de la ciberseguridad. En el informe se señala que el desarrollo de la ciberseguridad requerirá estándares sobre la interoperabilidad y estrategias más globales para superar las barreras técnicas de la infraestructura y abordar aspectos de la privacidad, la seguridad y otros de tipo jurídico. Existen numerosas normas genéricas utilizadas en aplicaciones de ciberseguridad para, por ejemplo, la codificación de video, seguridad, transmisión de multimedia y lenguajes de programación, muchas de las cuales han sido desarrolladas por el UIT-T. Estos y otros asuntos son abordados por expertos de las comisiones de estudio 16 y 17 del UIT-T, así como por otros organismos de normalización. Las normas internacionales sobre ciberseguridad deben basarse en “tecnologías maduras y estables” y no solo en tecnologías futuras avanzadas.

La Conferencia de Plenipotenciarios de 2010 celebrada en Guadalajara, México, aprobó una nueva Resolución, la Resolución 183 sobre “Aplicaciones de las telecomunicaciones/TIC para la ciberseguridad”, que encarga a la UIT “la expansión de las iniciativas de telecomunicaciones/TIC para la ciberseguridad y que coordine las actividades relativas a la ciberseguridad entre el Sector de Radiocomunicaciones (UIT-R), el Sector de Normalización de las Telecomunicaciones (UIT-T), el UIT-D y, en particular, fomente la sensibilización, generalización y creación de capacidades en lo que respecta la creación de normas de telecomunicaciones/TIC, y que informe de las conclusiones al Consejo de la UIT, según proceda”.

Además de la Resolución 183, la Conferencia de Plenipotenciarios de la UIT de Guadalajara aprobó el “Plan Estratégico de la Unión para 2012-2015” uno de cuyos objetivos estratégicos para el UIT-T es la “reducción de la brecha en materia de normalización: proporcionar apoyo y asistencia a los países en desarrollo en la reducción de la brecha en materia de normalización por lo que se refiere a asuntos relacionados con la normalización, infraestructuras y aplicaciones de las redes de información y comunicación, y los correspondientes materiales de capacitación para la creación de capacidades, teniendo en cuenta las características del entorno de las telecomunicaciones de los países en desarrollo”. Este objetivo se refiere a la ciberseguridad en el sentido de que la normativa técnica sobre ciberseguridad tiene que adaptarse a las redes existentes en los países en desarrollo.

La Conferencia Mundial de Desarrollo de las Telecomunicaciones celebrada en 2010 en Hyderabad, también aprobó la Resolución 65 sobre “Mejora del acceso a los servicios de atención sanitaria utilizando las tecnologías de la información y la comunicación”, en la que se encarga (a la Oficina de Desarrollo de las Telecomunicaciones) “que promueva la elaboración de normas de telecomunicaciones para la interconexión de redes de ciberseguridad con dispositivos médicos en el entorno de los países en desarrollo, junto con el Sector de Radiocomunicaciones y el Sector de Normalización de las Telecomunicaciones en particular”.

El siguiente estudio de caso muestra la experiencia de la India en el establecimiento de normativa nacional sobre ciberseguridad y concluye identificando las lecciones aprendidas y recomendaciones para otros países en desarrollo a la hora de establecer sus propias normas nacionales sobre ciberseguridad basadas en las existentes a nivel internacional.

⁶ www.itu.int/en/ITU-T/techwatch/Pages/ehealth-standards.aspx

2.2 Normalización en materia de cibernidad – Experiencia de un país en desarrollo

2.2.1 Introducción

⁷ La prestación de una asistencia sanitaria básica y mínimamente aceptable a la población rural de los países en desarrollo es un desafío continuo. Entre otros factores, los recursos limitados y la desequilibrada distribución de expertos sanitarios contribuye en gran medida a acentuar esta circunstancia. La India no es una excepción y una población de más de mil millones de habitantes distribuida en poblaciones muy distantes entre sí añade un reto adicional a la prestación de los niveles prescritos de asistencia sanitaria. La opción de adoptar las tecnologías de la información en el ámbito de la sanidad ha sido uno de los aspectos tenidos en cuenta para aumentar la eficacia de la prestación de asistencia sanitaria. Multitud de prestadores de asistencia sanitaria públicos y privados trabajan de forma aislada con posibilidades de comunicación muy limitadas entre los médicos u hospitales y, en consecuencia, funcionan de forma independiente. A la vista de esta situación, es necesario adoptar un sistema de información sanitaria normalizado en todo el país que satisfaga las necesidades de grupos muy diversos y que ofrezca valor al paciente.

Actualmente, muchos hospitales públicos y privados han adoptado los denominados sistemas de información hospitalaria (HIS, *hospital information systems*) que utilizan registros médicos electrónicos. Los proyectos de sistemas de información de gestión sanitaria de los gobiernos de los estados están realizando pruebas experimentales con dispositivos electrónicos de acceso. La India está comenzando a hacer progresos en el campo de la telemedicina y la cibernidad. Ante la creciente introducción de la telemedicina en el país, los responsables políticos de la India están convencidos de la necesidad de un conjunto de normas y directrices recomendadas sobre telemedicina, que debe refinarse continuamente, teniendo en cuenta la rápida mejora de los estándares de la asistencia sanitaria. Teniendo presente esta tendencia y a la vista de la situación internacional, en particular el crecimiento de sistemas no normalizados que dificultan el intercambio de información sanitaria en la mayoría de los países desarrollados, el Departamento de Tecnología de la Información (DTI) ha definido el marco para una Infraestructura de tecnología de la información para la asistencia sanitaria en la India (ITI) (1). Simultáneamente, y bajo la supervisión de una Comisión de alto nivel y de un grupo de trabajo técnico, se han propuesto un conjunto de normas y directrices para la práctica de la telemedicina en la India (2). Estos esfuerzos contribuyen en gran medida, entre otras iniciativas, a proponer normas fundamentales para el desarrollo de la red de información para la salud de la India. Como parte del esfuerzo innovador para la definición de la ITI, se consultó a las principales partes interesadas de la industria para definir normas nacionales sobre la información sanitaria, en un primer intento por definir un registro sanitario electrónico (HER) aceptable. El marco propuesto intentaba abarcar los estándares clínicos, los elementos de datos, los identificadores sanitarios, el conjunto de datos mínimo, el marco jurídico y las normas para la mensajería.

La iniciativa ha sido desarrollada ulteriormente por el ministerio usuario. Se ha creado un Subgrupo sobre Normas de telemedicina bajo los auspicios del Grupo especial para la telemedicina en la India, que a su vez ha sido constituido por el Ministerio de Sanidad y Bienestar Familiar. Los miembros del Subgrupo han sido seleccionados de entre distintos gobiernos, organismos e instituciones privadas que han llevado a cabo iniciativas sobre normas y directrices para telemedicina que han sido, en general, aceptadas. Este esfuerzo ha aprovechado aportaciones a la anterior iniciativa del DIT. Asimismo, una serie de iniciativas nacionales de normalización de servicios de las tecnologías de la información aplicables a la atención sanitaria, incluida la cibernidad, también han aprovechado dichas iniciativas pioneras. Entre ellas, se encuentra la iniciativa de la Comisión Nacional del Conocimiento, un órgano político decisorio de alto

⁷ Contribución de: Baljit Singh Bedi, Asesor de sistemas de información para la salud, Centro para el Desarrollo de Computación Avanzada (CDAC), dependiente del Ministerio de Comunicaciones y TI (MCIT), Gobierno de la India. Véase el documento [RGQ14.3.2-INF-0024](#)

nivel, por la que se creó un grupo de trabajo para presentar propuestas sobre el desarrollo de la red de información sanitaria de la India (I-HIND). El Subgrupo del Grupo especial del Ministerio de Sanidad y Bienestar Familiar también se ha beneficiado notablemente de los esfuerzos realizados en el campo del registro médico electrónico (EMR). Con la creciente utilización de las tecnologías de la información en los distintos ámbitos de la atención sanitaria, es previsible que estas iniciativas de normalización contribuyan decisivamente a mejorar la eficacia de la asistencia sanitaria en la India. Es deseable que las lecciones aprendidas durante este proceso puedan ser aprovechadas por otros países en desarrollo que realicen esfuerzos similares.

2.2.2 Inicio del proceso nacional de normalización

Países de todo el mundo han sido sensibles a los efectos de la introducción de las tecnologías de la información y la comunicación en distintos sectores de la economía. A pesar de sus lentos inicios, las economías en desarrollo han comenzado a recoger los frutos de dicha introducción a nivel de costos, calidad y accesibilidad a los servicios de asistencia sanitaria. Ello hace que éste sea un momento oportuno para que esos países adopten dichas tecnologías y, al mismo tiempo, aprendan de las experiencias de países desarrollados e inicien el proceso de normalización en el sector que tantos beneficios aporta. En algunos países, como en la India, donde se han desarrollado servicios de telemedicina que están operativos a través de múltiples y dispares redes, es urgente la necesidad de evolucionar las normas y las directrices para el desarrollo de la práctica de la telemedicina de una manera uniforme y con rigor científico. Teniendo en cuenta el catálogo de tecnologías de la información y de la salud, existen dos organismos fundamentales que deben responsabilizarse e impulsar del programa. En la India la primera iniciativa ha corrido a cargo del Ministerio de Comunicación y de las Tecnologías de la Información, que posteriormente ha sido relevado por el usuario principal, es decir, el Ministerio de Sanidad y Bienestar Familiar. A continuación se describen algunas de las medidas más importantes tomadas en este sentido, que pueden aplicarse igualmente a otros países en desarrollo:

a) Creación de un Grupo de trabajo de expertos y términos de referencia

Esta es la primera medida a tomar e implica una selección cuidadosa de expertos de las áreas especializadas afectadas. Los miembros deben pertenecer a asociaciones profesionales y de la industria, universidad, departamentos del gobierno, organizaciones de investigación y desarrollo que trabajen en el campo de los sistemas de información para la salud, asociaciones de usuarios, que sean responsables de la administración hospitalaria, profesionales destacados de las tecnologías de la información, suministradores de servicios y aplicaciones para la asistencia médica, fabricantes de equipos, médicos, etc. Todos ellos deben participar en los debates sobre los posibles problemas y en la recopilación de requisitos que sirvan para la elaboración de las normas técnicas, de tal forma que éstas sean adecuadas a la situación del país.

Debe mantenerse la posibilidad de invitar, cómo y cuando sea necesario, a otros expertos, como por ejemplo expertos jurídicos. En primer lugar, el grupo debe definir diligentemente los criterios fundamentales y la visión antes de avanzar en las deliberaciones necesarias para el cumplimiento de sus términos de referencia en el marco de los criterios seleccionados.

b) Definición de las normas – Objetivos fundamentales

Es importante que el órgano encargado de esta tarea tenga una clara visión de los objetivos de la definición de normas sobre la ciber salud y el sistema de información de gestión hospitalaria (HMIS) conexo. Éstos pueden ser los siguientes:

- Incrementar la accesibilidad a cuidados médicos de calidad para todos.
- Promover el crecimiento de la cibernidad y del HMIS.
- Identificar y apoyar los mecanismos de protección de la privacidad y la confidencialidad de los datos sanitarios de las personas y otros aspectos jurídicos y de seguridad.

- Ampliar la cooperación internacional en los aspectos científicos, jurídicos y éticos del uso de la cibernidad.
- Proporcionar un marco para el interfuncionamiento y la escalabilidad de los servicios basados en tecnologías de la información en el país y fuera del país.
- Generar beneficios a las partes interesadas incluidos suministradores, usuarios, público en general, etc.

c) Marco para la definición de directrices y normas

Esto afecta especialmente a la práctica de la telemedicina

- Interoperabilidad: permitir que las redes de telemedicina tengan interfaces que les permitan compartir aplicaciones sobre diversos sistemas en tiempo real o a través de interfaces sin solución de continuidad entre aplicaciones.
- Compatibilidad: capacidad de conectar sistemas de diferentes suministradores o distintas versiones del mismo sistema.
- Escalabilidad: posibilidad de añadir a equipos y sistemas utilizados en la telemedicina características y funciones modulares adicionales cuya incorporación sea facultativa.
- Portabilidad: capacidad de que los datos generados por una aplicación que corre en un sistema pueden ser trasladados a otras plataformas con un esfuerzo mínimo.

El marco director debe garantizar:

- La inclusión de todas las partes interesadas
- Recomendaciones que sean neutrales con respecto al suministrador

d) Protocolos clínicos y directrices

El Grupo de expertos también debe analizar los protocolos clínicos y las directrices necesarias. Los protocolos clínicos de la práctica de la telemedicina incluyen procedimientos de programación preliminares y procedimientos de consulta y funcionamiento de los equipos de telemedicina (por ejemplo, especificaciones de los sistemas de transmisión). Las normas técnicas clínicas para la calidad de imagen de una transmisión de video deben especificar los estándares técnicos necesarios para que un especialista, por ejemplo un dermatólogo, disponga de una imagen de buena calidad y el color necesario para hacer un diagnóstico correcto de un paciente.

e) Términos de referencia

Para que un grupo de trabajo de expertos inicie sus deliberaciones es necesario que se definan unos términos de referencia cuidadosamente seleccionados que enmarquen adecuadamente la tarea a realizar. A continuación se ilustra un ejemplo de términos de referencia para un grupo de trabajo sobre telemedicina/cibernidad:

1. Deliberar exhaustivamente sobre las normas internacionales existentes y recomendar aquellas que sean aplicables a las necesidades del país.
2. Determinar los diversos aspectos de la interoperabilidad entre redes y equipos que deben funcionar conjuntamente.
3. Elaborar los requisitos de compatibilidad de las tecnologías con el sistema de información hospitalaria existente en la mayor medida posible mediante las normas necesarias.
4. Definir la escalabilidad de las tecnologías adoptadas y su capacidad de evolucionar a capacidades ampliadas.
5. Proponer la estructura de una norma de sistema de registro médico electrónico (EMR).

6. Considerar la compatibilidad de la información digital normalizada con las distintas tecnologías de comunicación disponibles en el país, como la RDSI, RTPC, VSAT, IP inalámbrica, etc.
7. Normalizar los requisitos de videoconferencia para telemedicina y su aplicabilidad de forma económica.
8. Normalizar claramente los requisitos de las diversas áreas médicas, como radiología, cardiología, patología, etc., en materia de telemedicina y la compatibilidad de cada uno de los sistemas con los sistemas de telemedicina.
9. Normalizar la metodología de transmisión y el formato de los registros de los pacientes, incluidos los datos médicos, su cifrado y aspectos de confidencialidad.
10. Recomendar instrumentos de diagnóstico médico normalizados como ECG, aparatos de rayos X, etc., incluidos los requisitos del sistema de cámaras para videoconferencia
11. Recomendar equipos periféricos obligatorios/facultativos para los sistemas de telemedicina
12. Proponer normas de privacidad y seguridad.
13. Proponer un marco jurídico.

Es necesario establecer un calendario para la entrega de las recomendaciones del grupo. También puede ser de utilidad mantener un sitio web que recoja la actividad y permita la presentación de comentarios que enriquezcan los debates. De cara a un consenso final, es conveniente celebrar talleres en los que se invite a las partes interesadas a presentar, debatir y finalizar las recomendaciones.

2.2.3 Análisis de las normas técnicas fundamentales

- Orientaciones sobre el crecimiento del ecosistema de tecnologías de la información para la asistencia sanitaria

Se han dedicado gran cantidad de esfuerzos para regular/orientar el crecimiento del ecosistema de tecnologías de la información para la asistencia sanitaria. Estos esfuerzos son consecuencia de las necesidades urgentes de normalización de procesos para la representación y la transmisión de información sanitaria entre sistemas. Cuando un país en desarrollo acomete la tarea de proponer normas sobre la cibernidad y los sistemas de información para la gestión hospitalaria (HMIS), es necesario realizar previamente un estudio sobre la situación internacional, las organizaciones que trabajan en este campo y la adopción real de las normas analizadas, así como su aceptación y utilización en otros países. Muchas de las organizaciones de normalización y grupos de interés especial trabajan activamente en la normalización para abordar los asuntos relacionados con la compartición de datos sanitarios, la estructura de los datos, la gestión del acceso, la normalización de los procesos clínicos y de negocio de la atención sanitaria y la seguridad y privacidad. A continuación se mencionan algunas de las normas fundamentales que los países en desarrollo deben estudiar y considerar para su adopción en relación con la cibernidad y el HMIS junto con el nombre de la organización que las difunde. Son igualmente relevantes para entornos rurales y urbanos.

- Normas sobre registros sanitarios electrónicos (EHR) e intercambio de datos
 - ISO/TS 18308-Requirements for an electronic health record architecture (Requisitos de una arquitectura de registros sanitarios electrónicos)

Esta norma ha sido desarrollada por el comité técnico (TC) 215 que trabaja en el desarrollo de normas sobre sistemas de información sanitarios de la Organización Internacional de Normalización (ISO). La norma proporciona la definición y características básicas de los EHR y especifica sus requisitos.

- CEN/TC 251 EN 13606 (EHRcom)

CEN/TC 251 EN 13606 (EHRcom) es una norma del Comité técnico (TC) 215 del Comité Europeo de Normalización (CEN) que consta de cinco partes. Especifica la estructura, contenido, comunicación y política de seguridad de las comunicaciones de los EHR para lograr la interoperabilidad semántica durante el intercambio de información en otro EHR.

- Imágenes digitales y comunicación en medicina (DICOM)

DICOM (*Digital Imaging and Communications in Medicine*) es una norma de la industria creada por el Colegio Americano de Radiólogos (ACR) y la Asociación Nacional de fabricantes de equipos eléctricos (NEMA) que facilita el intercambio y procesamiento de imágenes médicas en formato digital. Los dispositivos de adquisición de imágenes (por ejemplo, de Tomografía Computarizada), los archivos de imágenes, los dispositivos para la impresión y las estaciones de trabajo de imágenes para el diagnóstico de distintos suministradores pueden conectarse a una infraestructura de información común e integrada con otros sistemas de información (por ejemplo, servicios de archivo y comunicación de imágenes (PACS), HIS, RIS). La versión actual es la DICOM PS.3.0-2009

- Normas “Health Level Seven” (HL7)

La norma HL7 del Instituto Nacional Americano de Normalización (ANSI) para mensajería en entornos clínicos, es una norma para el intercambio mensajes clínicos entre diferentes sistemas de telemedicina. HL7 es el acrónimo del inglés “Health Level Seven”; el término “Level 7” (nivel 7) se refiere al nivel más alto del modelo de interconexión de sistemas abiertos (OSI) de la ISO. Las diferentes versiones incluyen HL7 2.x, HL7v3 y HL7 CDA. La versión HL7v2.x define la especificación de interoperabilidad para el envío y recepción de eventos de atención sanitaria y de consultas en forma de mensajes. La versión actual HL7v3 se basa en el paradigma de la orientación a objetos y proporciona especificaciones en términos de clases y de objetos. La arquitectura de la documentación clínica de HL7 es una norma de marcado de documentos que especifica la estructura y la semántica de los ‘documentos clínicos’ para su intercambio.

- Norma sobre el registro de la atención continuada (CCR, *Continuity of Care Record*) - ASTM

El registro de la atención continuada (CCR, *Continuity of Care Record*) es una norma desarrollada conjuntamente por la Sociedad Americana de Pruebas y Materiales (ASTM International), la Sociedad Médica de Massachusetts (MMS, *Massachusetts Medical Society*), la Sociedad sobre los sistemas y la gestión de la información sanitaria (HIMSS, *Health Information Management & Systems Society*), y la Academia Americana de Médicos de Familia (AAFP, *American Academy of Family Physicians*) con el fin de especificar el conjunto mínimo de datos necesarios para elaborar el resumen de los cuidados médicos prestados a un paciente cuando éste pasa de un prestador de asistencia sanitaria a otro. El objetivo de la norma es reducir al mínimo los errores, evitar el retraso en la aplicación de un tratamiento debido a una información sanitaria inadecuada en el cambio y mejorar la atención sanitaria en todo el país.

- CEN/TC 251 EN 13940

Es una norma europea del Comité técnico (TC) 251 del Comité Europeo de Normalización (CEN) denominada ‘Health Informatics-System of concepts to support continuity of care’ (CONTsys). La norma define los conceptos y los procesos utilizados durante las actividades de atención sanitaria continuada de los pacientes.

- Normas clínicas

Las normas de representación de datos clínicos, o conjuntos de códigos, son una representación sistemática de la información sanitaria. En el sector de la salud se utilizan una gran cantidad de normas clínicas para la codificación de información sobre enfermedades, procedimientos, observación clínica, medicamentos, procedimientos de enfermería, consumibles, cirugías etc. que son cruciales en el proceso de normalización. La mayoría de los países han adoptado conjuntos de códigos de conformidad con sus requisitos y la naturaleza de la utilización. La actividad de normalización sobre cibernidad, HMIS, etc. de un país en desarrollo precisa de un análisis y adopción cuidadosa de normas clínicas. Éstas son fundamentales para la interoperabilidad de un sistema de información sanitaria nacional exitoso que contribuya a aumentar la seguridad del paciente. Existen tres categorías principales de normas clínicas:

- Códigos de enfermedades
- Códigos de procedimientos
- Códigos de observación clínica

En los párrafos siguientes se presenta una lista de algunos sistemas de códigos predominantes y muy utilizados.

- Clasificación Internacional de Enfermedades (CIE)

La Organización Mundial de la Salud (OMS) inició el desarrollo del sistema de codificación de la Clasificación Estadística Internacional de Enfermedades (CIE) para promover la comparación a nivel internacional de la recopilación, procesamiento, clasificación y presentación de estadísticas de mortalidad y morbilidad. La versión más actualizada es la CIE-10, que se utiliza en muchos países.

- Clasificación Internacional de Enfermedades –versión 10 – Sistema de Codificación de Procedimientos (ICD-10-PCS)

La codificación procedimental es la traducción de la terminología médica de procedimiento en un código.

- Nomenclatura sistematizada médica - Términos clínicos (SNOMED-CT)

La nomenclatura sistematizada médica - términos clínicos (SNOMED-CT) es un conjunto terminológico clínico completo desarrollado por la Organización internacional de desarrollo de normas de terminología sanitaria (IHSTDO, *International Health Terminology Standards Development Organization*) que incorpora códigos de diagnósticos, tratamientos y procedimientos aplicados durante los procesos de asistencia sanitaria.

- Terminología actualizada de procedimientos médicos (CPT)

La terminología actualizada de procedimientos médicos (CPT, *Current Procedural Terminology*) ha sido desarrollada por la Asociación Médica Americana (AMA, *American Medical Association*)

- Sistema de lenguaje médico unificado (UMLS, *Unified Medical Language System*)

El UMLS ha sido diseñado y es mantenido por la Biblioteca Nacional de Medicina de los Estados Unidos de América. Proporciona una correspondencia entre terminologías de codificación existentes. Es un sistema eficiente para la interoperabilidad entre organizaciones que utilizan el mismo modelo de información pero distintos conjuntos de códigos en dicho modelo de información.

- Normas de videoconferencia

Este es también un aspecto importante de la cibernidad/telemedicina. Afortunadamente existen normas internacionales aceptadas establecidas por la Unión Internacional de Telecomunicaciones para la interoperabilidad de los servicios de videoconferencia para distintos modos de conectividad.

- Recomendaciones UIT-T H.32x

- Organizaciones de normalización

Es importante señalar que las organizaciones de normalización como el Comité Europeo de Normalización (CEN), la Sociedad Americana de Pruebas y Materiales (ASTM, *American Society for Testing and Materials*), la Organización Internacional de Normalización (ISO), la Organización Mundial de la Salud (OMS), la Unión Internacional de las Telecomunicaciones (UIT), el Instituto Nacional Americano de Normalización (ANSI), la Sociedad de sistemas y gestión de información hospitalaria (HIMSS), etc. han trabajado en diversos aspectos normativos de la cibernidad, los HMIS y otras ramas de los sistemas de información para la salud. A lo largo del tiempo, dichas organizaciones han elaborado un conjunto de importantes normas. Los países en desarrollo que aborden la introducción de normas encontrarán de gran utilidad el análisis de la normativa existente para verificar la conveniencia de su adopción. Igualmente, algunos informes recientes, como el elaborado por la UIT al respecto (3), son de utilidad para disponer de una amplia visión de todos estos asuntos.

2.2.4 Normas sobre sistemas de información para la gestión hospitalaria (HMIS)

Un aspecto muy importante en la normalización de los HMIS está relacionado con los registros médicos electrónicos (EMR) o registros sanitarios electrónicos (EHR), las normas sobre el intercambio de datos y las normas clínicas. En el apartado 3.2 de este documento se ofrece más información sobre este asunto y

sobre algunas de las normas conexas. La ventaja básica de utilizar normas en los HMIS es permitir que las aplicaciones de un HMIS puedan comunicarse con otras aplicaciones y generar un registro médico uniforme de pacientes para distintos HMIS. En general, el proceso de normalización en términos del HMIS se aplica de igual forma a hospitales grandes y pequeños. No obstante, la principal diferencia entre las dos categorías de hospitales es en términos de funcionalidad hospitalaria y escala. Asimismo, debe tenerse en cuenta en qué entorno se adoptan las normas. Los hospitales pequeños pueden tener uno o dos tipos de sistemas, por ejemplo, un registro de pacientes y un sistema de gestión de la información de laboratorio. La adopción de una única norma HL7 en dicho entorno es suficiente, mientras que en un gran hospital con varios sistemas, incluido un servidor para el archivo y comunicación de imágenes, HMIS, sistema de gestión del laboratorio y sistemas en los departamentos de radiología, el escenario es más complejo. En ese caso es necesario adoptar múltiples normas y además deben adoptarse normas como la de perfiles IHE, que define los perfiles de interoperabilidad entre distintas normas y simplifica el flujo del proceso.

Servicios HMIS y de ciberseguridad

La integración de los servicios de ciberseguridad con el HMIS de un hospital mejora notablemente la eficacia de la interacción entre la ciberseguridad y el hospital de especialidades. Con el crecimiento de la ciberseguridad/telemedicina, algunos hospitales de especialidades están haciendo de ello una funcionalidad que deben cumplir los suministradores de HMIS. En una de las redes de telemedicina puesta en servicio con éxito en Kerala, India, esta funcionalidad ha añadido valor para los pacientes de cáncer de zonas distantes. Además de fijar las citas de consultas en línea, el EMR del paciente incluido en la base de datos del HMIS DICOM está disponible en ambos emplazamientos con la autorización del HMIS, y su contenido se actualiza después de cada consulta.

Soluciones de computación en la nube para HMIS

La computación en la nube es otra modalidad que los países en desarrollo deben tener en cuenta seriamente para su adopción en los HMIS de los hospitales. El mayor beneficio del modelo en la nube es la posibilidad de disponer de unas comunicaciones y una colaboración más eficaz, además de una cobertura uniforme de la solución en todo el país. También reduce considerablemente los costos globales y añade normas de interoperabilidad a los servicios ofrecidos. Un sistema público basado en la nube que proporcione servicios HMIS en los distintos niveles de gestión hospitalaria puede llegar a revolucionar el escenario de prestación de asistencia sanitaria en un país en desarrollo. Algunos estados de la India han tomado medidas para utilizar soluciones de computación en la nube en una serie de hospitales bajo su responsabilidad.

2.2.5 Aspectos relacionados con el marco regulatorio y jurídico y mecanismos de cumplimiento

Dado que los servicios de ciberseguridad se enmarcan en diversos elementos jurídicos y en la jurisprudencia, es importante comprender cabalmente los aspectos jurídicos. Puesto que los procedimientos jurisdiccionales son distintos en cada país, las implicaciones jurídicas de la aplicación de servicios de ciberseguridad también serán distintas. En la India no existe un marco jurídico que controle el crecimiento de la ciberseguridad. La puesta en marcha de dicho marco jurídico en un país en desarrollo precisa tiempo, pues ha de garantizar el adecuado alineamiento entre las partes interesadas para lograr un objetivo nacional cuando el país decida integrar soluciones de ciberseguridad en su asistencia sanitaria.

El Subgrupo sobre Normas para la Telemedicina, creado bajo los auspicios del Grupo especial para la Telemedicina de la India, ha considerado en detalle algunos de estos asuntos antes de remitir su informe. Este aspecto también está siendo actualmente considerado por la Asociación de sistemas de información médica de la India (IAMI) y por la Sociedad de Telemedicina de la India (TSI), dos de las principales asociaciones profesionales en esta esfera. A continuación se presentan escuetamente algunos de los aspectos que pueden ser objeto de recomendaciones, que han sido considerados por el Subgrupo y que deben ser abordados.

Política de retención de datos

El formato electrónico de los datos médicos debe mantenerse por un periodo igual o superior al de los registros médicos documentales. Es necesario disponer de los sistemas de respaldo necesarios para recuperar datos que puedan perderse debido a virus/incendios u otros percances.

Privacidad / confidencialidad del paciente y normas sobre seguridad

Siempre debe mantenerse la privacidad y la confidencialidad del paciente. Estas normas se refieren y abarcan a todos los demás tipos de normas. A este respecto, deben tenerse en cuenta diversos derechos y privilegios jurídicos del paciente. Deben tenerse presentes la autenticación, el control de acceso y la seguridad de la transmisión. El usuario debe poder exigir el anonimato de los datos transmitidos. Los datos transmitidos en modo anónimo no deben permitir, en sí mismos, la identificación del paciente. Deben adaptarse las medidas de seguridad adecuadas contra actuaciones intencionadas o no intencionadas que puedan erosionar la privacidad del paciente. Algunas de las normas que deben desarrollarse son las relativas al cifrado y descifrado de información sanitaria a distintos niveles.

Consentimiento del paciente

Los usuarios de la telemedicina deben ser conscientes de los aspectos de privacidad relacionados con la transferencia o compartición de datos del paciente. El consentimiento informado del paciente debe producirse preferentemente antes de la interacción de telemedicina que implique la transferencia de datos que permitan la identificación del mismo.

Calidad de servicio

A fin de garantizar la calidad de servicio, una entidad que participe en una interacción debe asegurar que los datos no tienen errores y que la interacción se realiza sin interrupciones y es concluyente.

Propiedad de los datos

El paciente y/o el tutor legal es el único propietario jurídicamente autorizado de los datos médicos. El emplazamiento, el consultor y el especialista son custodios de los mismos y por ende, deben tomar todas las precauciones para salvaguardar información íntima, de identificación, etc.

Resolución de controversias

Existen una serie de aspectos jurídicos sobre responsabilidad y derechos relacionados con los métodos de la telemedicina que están sujetos a incertidumbres. La resolución de controversias es un aspecto que debe estar claramente especificado.

2.2.6 Mecanismos de cumplimiento y desafíos

Los mecanismos para que las partes interesadas cumplan las normas establecidas es uno de los mayores desafíos de casi todos los países con un proceso de normalización en marcha. El cumplimiento de las normas de los servicios de ciberseguridad debe contemplarse desde dos perspectivas: la representación y la transmisión de la información de atención sanitaria. La representación de la información incluye la estructura de la información y el tipo de contenido de ésta. También se incluye la normalización de los términos clínicos utilizados en la información de asistencia sanitaria. La transmisión incluye el cumplimiento de las normas aplicables de acuerdo con la naturaleza del sistema, Por ejemplo, el sistema de información para la gestión sanitaria (HMIS) puede utilizar las normas HL7 para la transmisión de información y utilizar la norma DICOM de la NEMA para aplicaciones radiológicas y de dispositivos médicos. Las directrices regulatorias ayudan a que la industria de las tecnologías de la información aplicadas a la sanidad cumpla la normativa. No obstante, este proceso supone nuevos desafíos tales como los mayores esfuerzos y costos asociados a productos que cumplen normas específicas y los necesarios para ampliar el cumplimiento de las normas a otros productos.

El primer paso, es decir llegar a un consenso entre las partes interesadas sobre qué normas son aceptables ya se trate de organizaciones internacionales o nacionales, es un asunto que generalmente requiere mucho tiempo. La adopción de normas que aúnen los intereses de todas las partes interesadas y la necesaria neutralidad respecto al suministro, hace de éste un ejercicio difícil y que consume mucho tiempo. Una vez dado ese paso, el proceso para que las normas que se han considerado aceptables y recomendables sean obligatorias es distinto en cada país, según la gestión de gobierno vigente.

En general, los países en desarrollo tienen dos ventajas a la hora de iniciar el proceso de integrar la normalización en su sistema. En primer lugar, no están condicionados por un gran número de sistemas preexistentes que puedan verse afectados. En segundo lugar, pueden analizar y aprovechar la experiencia de los países desarrollados y de algunos países en desarrollo que han avanzado en el mismo proceso. Simultáneamente, estos países deben hacer frente a un doble desafío, por un lado el nivel de conocimientos de sus recursos humanos y, por otro, la necesidad de conjugar de forma óptima el impacto financiero negativo a corto plazo con la expectativa de un retorno de la inversión a largo plazo.

Es indudable que las primeras medidas destinadas a sensibilizar y centrar la atención en la actividad exige un esfuerzo de liderazgo. Bajo ese liderazgo deben organizarse los diversos grupos de trabajo en los que participen las partes interesadas con un objetivo común. Deben entenderse cabalmente los mecanismos de funcionamiento propios del país y actuar en consecuencia ante los responsables políticos. El primero de ellos es que para el establecimiento de un comité/grupo de trabajo de expertos es necesaria la autorización o consenso de la autoridad competente con el fin de que sus ulteriores recomendaciones tengan el peso necesario. A continuación se exponen algunas lecciones aprendidas a este respecto en el caso de la India.

Lecciones aprendidas y recomendaciones para otros países en desarrollo

El enorme crecimiento del sector de las tecnologías de la información y del software en los dos últimos decenios ha creado un gran interés en la India por los servicios que pueden aprovechar dicho crecimiento. Ha habido un gran desarrollo de aplicaciones, que finalmente también se han introducido en el sector de la asistencia sanitaria. El elevado porcentaje de población rural, junto a unos recursos humanos clínicos inversamente proporcionales y la dispersión de la población, han permitido identificar el gran potencial de la telemedicina. Ello ha conducido al despliegue de numerosas redes de telemedicina, promovidas principalmente por los ministerios estatales de tecnología y por los departamentos de tecnología espacial, que se apoyaron en la tecnología satelital, y por el Ministerio de Comunicaciones y Tecnologías de la Información (MCIT). En este periodo, el MCIT creó un grupo de trabajo técnico que propuso la adopción de normas en materia de telemedicina y simultáneamente abordó un estudio con el objetivo de proponer el marco adecuado para las normas asociadas a la infraestructura de tecnologías de la información para la salud. Ambas recomendaciones fueron publicadas en mayo de 2003 tras ser ampliamente debatidas en talleres que contaron con la participación de un gran número de partes interesadas de los sectores público y privado, incluido el gobierno y las universidades en los campos médico y tecnológico.

Se debatieron los problemas relativos a la instauración de la obligatoriedad de las recomendaciones. En primer lugar, se observó que cualquier actividad legislativa debía ser impulsada por el principal usuario, a saber, el Ministerio de Sanidad que debía aplicar modelos de negocio propios de su actividad en lugar de hacerlo el Ministerio de Comunicaciones y Tecnologías de la Información, que había tomado la iniciativa previamente. Este aspecto se reveló especialmente tedioso. Aplicando un enfoque alternativo, en septiembre de 2003 se decidió que las contribuciones se recogieran en el sitio web del Ministerio de Comunicaciones y Tecnologías de la Información. Las recomendaciones se redactaron durante un proceso llevado con diligencia y que tuvo en cuenta y consultó a expertos destacados y a la mayoría de las partes interesadas, de forma que los documentos pasaron a ser directrices de aplicación para la industria y partes interesadas. Algunos departamentos de gobiernos estatales incluyeron dichas directrices en sus requisitos básicos, al tiempo que hacían públicas sus intenciones de informatizar las instituciones médicas. Esta metodología dio una gran notoriedad pública a este asunto, y generó una gran sensibilización e interés en el cumplimiento de las normas en las etapas iniciales de la introducción generalizada de la cibernidad en la India, todo lo cual puede ser un ejemplo para otros países en desarrollo. No obstante, para que las recomendaciones pasen a ser de obligado cumplimiento para los

sectores público y privado, es necesario elaborar y aprobar la legislación pertinente de acuerdo con los procesos legislativos de cada país.

También pueden realizarse actividades promocionales con el apoyo del Ministerio/Departamento afectado del país con el fin de generar la motivación necesaria para que las partes interesadas adopten las normas aceptadas. Por ejemplo, el Ministerio de Comunicaciones y Tecnologías de la Información de la India apoyó a una de sus sociedades científicas en el desarrollo de conjuntos de herramientas software para DICOM y HL7. DICOM es una de las normas principales sobre imágenes y mensajería en el ámbito médico que ha sido aceptada por la asociación radiológica. HL7 es una de las normas principales en materia de mensajería, transferencia de información y gestión en el ámbito médico. Esta norma se utiliza ampliamente en los sistemas de información y mensajería médica. Actualmente existen muy pocas aplicaciones disponibles en la industria que soporten dicha normas por su complejidad y la ardua y amplia tarea necesaria para su implantación. No obstante, es previsible que a corto plazo exista una demanda relevante de dichas tecnologías. Las librerías de clase DICOM y HL7 garantizan que la inclusión de DICOM y de HL7 en cualquier aplicación sea sencilla y se cumplan las normas. Esas librerías también pueden ser utilizadas por los fabricantes de dispositivos médicos para que sus dispositivos sean conformes con DICOM y HL7.

Existe la concepción equivocada entre los suministradores de que el cumplimiento de normas puede reducir la cuota de mercado de sus productos ya que puede reducir el conjunto de características propias y específicas del suministrador. Esta equivocación debe aclararse sensibilizando sobre la importancia de las posibles oportunidades futuras que genera el cumplimiento de la normativa.

Por otra parte, el órgano regulatorio responsable de la transformación de las tecnologías de la información aplicadas a la asistencia sanitaria puede emplear determinados mecanismos para conseguir la conformidad con las directrices. El documento de directrices reglamentarias debe describir la utilización de las normas de acuerdo con la naturaleza de los servicios de ciberseguridad. Uno de los mecanismos eficaces es incentivar cada una de las conformidades con la normativa de los prestadores de asistencia sanitaria. Para ello, debe evaluarse el cumplimiento de las normas. Ello puede hacerse mediante una infraestructura de certificación de servicios de ciberseguridad que permita a los prestadores de asistencia sanitaria obtener certificados de cumplimiento. Este mecanismo puede ayudar a que el órgano regulatorio haga que en el futuro la certificación de los servicios de ciberseguridad sea obligatoria.

Referencias

- [1] Health Unite: Recommended Framework for Information Technology Infrastructure for Health in India, DIT, Ministry of Communication and IT.
- [2] Report of the Technical Working Group on Telemedicine Standardization: Recommended Guidelines & Standards for Practice of Telemedicine in India, septiembre, 2003; DIT, Ministry of Communication and IT.
- [3] Standards and eHealth: Informe de seguimiento tecnológico de la UIT (ITU Technology Watch), enero de 2011.

2.3 Análisis de los factores económicos de la cibernidad

⁸ Uno de los aspectos estratégicos prometedores de la cibernidad es el aumento de la eficacia de la atención sanitaria, es decir, la garantía de una atención médica de alta calidad durante 24 horas al día y 7 días a la semana a todos los ciudadanos, sin importar dónde se encuentren y, al mismo tiempo, reducir el gasto sanitario total (el gasto sanitario total es la suma del gasto sanitario público y privado). El gasto sanitario total de todos los países, como porcentaje del producto interior bruto (PIB) ha crecido gradualmente, pero sin cesar, en los últimos decenios y pronto alcanzará un nivel en el que la carga de los costos dejarán de ser soportables [1]. Es obvio que los países en desarrollo no pueden mantener el mismo crecimiento de fondos para la atención sanitaria y, por tanto, deben encontrar una alternativa que les permita alcanzar a través de vías alternativas el mismo nivel de servicio sanitario que se ofrece a los ciudadanos en las regiones desarrolladas. La mejor solución es la cibernidad, en la medida que la reducción del gasto sanitario esté acompañada de una elevada calidad de la asistencia sanitaria.

El debate sobre la rentabilidad económica de las aplicaciones de la cibernidad es realmente importante ya que los desarrollos y aplicaciones de cibernidad forman parte de la estrategia de numerosos gobiernos locales así como de organismos internacionales como la OMS, la UIT o la Unión Europea. Por ese motivo, para la India también es crucial el asunto de la rentabilidad de la cibernidad.

El texto que sigue resume los resultados más recientes en relación con el análisis económico de la cibernidad y responde a las preguntas de “si la cibernidad es económicamente rentable” y “cómo puede evaluarse el potencial efecto económico de la cibernidad antes de su implantación efectiva”.

2.3.1 Factores económicos de la cibernidad

La función del análisis de los factores económicos de la cibernidad es evaluar los costos y los beneficios de una iniciativa de cibernidad a lo largo del tiempo y para las distintas partes interesadas, incluidos los ciudadanos, pacientes, profesionales sanitarios y otros trabajadores de la sanidad, organizaciones de prestadores de asistencia sanitaria y otros agentes.

Estudios iniciales de rentabilidad [2] así como algunas publicaciones recientes [3] son concluyentes e indican que no existe una evidencia suficiente de que la cibernidad sea una forma rentable de prestar la asistencia sanitaria. Algunos autores incluso subrayan que los costos de las consultas a distancia son superiores a los de citas ambulatorias de los pacientes, aunque apoyan la hipótesis de que las pérdidas de productividad son menores [4].

Sin embargo, los datos de estudios recientes sobre los factores económicos de la cibernidad de casos a gran escala (es decir, basados en un gran número de consultas o en varios años de experiencia) apuntan justamente en sentido contrario, por ejemplo:

- Un estudio japonés, publicado en 2013, analizó los efectos a largo plazo de la cibernidad en los residentes de la ciudad de Nishi-aizu, Fukushima, Japón, entre 2002 y 2010. Los autores han comparado el gasto médico y los días de tratamiento de usuarios teleatendidos y no teleatendidos que padecían enfermedades crónicas (afectados por apoplejía, hipertensión, insuficiencia cardíaca y diabetes). La aplicación de métodos estadísticos rigurosos, incluido el método generalizado de los momentos, ha revelado que los pacientes usuarios de la teleasistencia requieren menos días de tratamiento y un gasto médico inferior que los no usuarios [5].
- Una encuesta detallada realizada en Australia reveló el resultado de cinco años de teleconsultas pediátricas. Los autores subrayan que el costo total de 1.499 consultas fue de 955.996 dólares australianos. El costo potencial estimado de un servicio ambulatorio para el mismo número de pacientes en el Royal Children's Hospital de Brisbane es de 1.553.264 dólares australianos; por tanto,

⁸ Contribución de Malina Jordanova, Space Research & Technology Institute, Academia de las Ciencias de Bulgaria, Bulgaria.

los servicios de teleconsultas pediátricas supusieron un ahorro neto de aproximadamente 600.000 dólares australianos para el prestador de servicios sanitarios [6].

- La evidencia más clara de la eficacia de la cibernidad en resultados clínicos se ha producido en el caso de televigilancia en el hogar de enfermedades crónicas, hipertensión, diabetes y SIDA. Existe una evidencia razonable de que en la medicina de emergencia la cibernidad ahorra costos y mantiene la misma calidad que la atención en persona y es beneficiosa en unidades de cuidados intensivos de cirugía y de neonatales, así como en la derivación de pacientes de neurocirugía [7].

¿A qué se deben puntos de vista tan distintos en relación con la rentabilidad de la cibernidad? Las respuestas son las siguientes:

- Los datos son limitados o los análisis se basan en artículos publicados principalmente en las revistas “Telemedicine and eHealth” y “Journal of Telemedicine and Telecare”. Ambas publican predominantemente artículos de comunidades de habla inglesa;
- Se observa un reducido tamaño de las muestras, la mayoría de los estudios se basan en muestras de menos de 100 participantes;
- Muy pocos documentos miden resultados directamente ligados a soluciones de cibernidad;
- Sólo el 26% de los estudios informan del plazo durante el que se desarrolla el estudio, que es un parámetro esencial para determinar los beneficios a largo plazo en términos de costos;
- Se utilizan herramientas de evaluación pobres y se observa que no se aplica una metodología generalmente aceptada;
- El periodo de tiempo hasta el umbral de rentabilidad es muy largo;
- Existen cambios constantes en la tecnología y en los costos.

Cuando se consideran estudios de larga duración realizados en “países menos adelantados”, como Brasil y Rusia, los datos son bastante interesantes y convincentes.

2.3.2 *Qué, dónde, cuánto*

Según estimaciones de médicos de Siberia occidental, basadas en casi diez años de práctica en el ámbito de la cibernidad, el costo para los pacientes de consultas virtuales realizadas por un experto altamente especializado ubicado en Moscú fue aproximadamente 40 menor de lo que hubieran gastado si hubieran tenido que viajar a la consulta del mismo experto en Moscú. La calidad del servicio fue la misma [8]. Los autores [10] han hecho un análisis detallado del retorno de las inversiones de actividades de cibernidad clínica y han demostrado que las inversiones comienzan a recuperarse tras un periodo inicial de 2,5 años. Aunque la mayor parte de sus publicaciones están en ruso, es interesante examinar las que se han realizado en otros idiomas o las que están traducidas, ya que el retorno de la inversión es solo uno de los 20 índices aplicados en sus análisis económicos de proyectos de telemedicina.

Otro ejemplo es el servicio de telecardiología del Estado de Minas Gerais de Brasil. Minas Gerais tiene un territorio equivalente al de Francia, una población de 19.000.000 de habitantes y 853 pueblos y ciudades. El servicio de telecardiología ha estado operativo desde junio de 2006 en 82 pueblos de zonas distantes y aisladas. Los resultados preliminares de la evaluación de viabilidad económica han mostrado que los ahorros derivados de una reducción del 1,5% del número de tratamientos realizados fuera de los pueblos de los pacientes son suficientes para cubrir los costos operacionales del sistema [10].

Una selección cuidadosa de las aplicaciones de cibernidad siempre ofrece resultados beneficiosos. En un estudio realizado en un país comparativamente “más pequeño”, Italia, en 2001, se puso en marcha un número de teléfono gratuito para niños y adolescentes con diabetes de tipo 1 en la región de Parma con un régimen de funcionamiento 24/7 [11]. Una amplia encuesta realizada desde comienzos de 2001 hasta finales de 2006 mostró que el número total de niños que recibieron ayuda fue de 421 (con una edad media de 10,8 años y una duración media de la diabetes de 4,5 años). En el periodo de cinco años se registraron 20.075 llamadas, una media de 11 llamadas diarias. El 52% de las llamadas fueron de emergencia. Gracias al servicio, la tasa de admisión en hospitales por cetoacidosis diabética se redujo de

10 casos por cada 100 niños y año a 3 casos por cada 100 niños y año. Dicho de otro modo, los costos de admisión hospitalaria se redujeron un 60% [11].

Desde 1994 se ha ofrecido un servicio de cibernidad en la ciudad de Nishiazu, Japón. Se transmiten parámetros fisiológicos vitales a una institución médica distante que vigila pacientes con diagnósticos de alta presión sanguínea, infarto cerebral, apoplejía, diabetes y de edad avanzada. En varias publicaciones [12-13] se ha analizado la rentabilidad del sistema. En ellas se señala que los gastos médicos por enfermedades relacionadas con el estilo de vida cayeron un 20,7% en el caso de usuarios de la cibernidad. Los autores también han demostrado que quienes hacen uso a largo plazo de la cibernidad realizan un gasto médico inferior a quienes lo han utilizado durante un plazo de tiempo menor, resultado que aporta otra prueba adicional sobre que para verificar si existe rentabilidad a largo plazo es necesario concentrarse en estudios a gran escala y de larga duración.

Nuestros resultados también muestran que las aplicaciones de la cibernidad pueden ser rentables. No obstante, siempre debe hacerse la pregunta siguiente: ¿rentabilidad para quién? En base a 6.000 horas de consultas durante cinco años, ha quedado claro que los pacientes ahorran dinero [14]. Las consultas virtuales son de tres a cuatro veces más baratas que las visitas personales.

2.3.3 *Cómo evaluar los impactos económicos*

Debe subrayarse que no existe una metodología ampliamente aceptada y reconocida para estimar el efecto económico de la aplicación de la cibernidad. Una de las formas más sencillas es calcular el retorno de la inversión (ROI, en sus siglas en inglés).

El ROI es una medida del rendimiento que es utilizada para evaluar la eficiencia de una inversión o para comparar la eficiencia de distintas inversiones. Para calcularlo, el beneficio de una inversión se divide por el costo de la misma; el resultado se expresa como una relación o porcentaje.

Otra forma, probablemente más adecuada, de valorar la eficiencia económica, especialmente en los casos más comunes, es decir, los que implican consultas y/o apoyo a distancia, tiene en cuenta lo siguiente:

- El número y la distancia al punto de derivación de pacientes, los costos de personal y de transporte, la amortización, los impuestos y los seguros de los vehículos utilizados para el transporte, y los costos de las comunicaciones;
- El costo adicional del personal de administración, técnico y sanitario y el costo de las comunicaciones;
- Todos los costos necesarios para el funcionamiento del sistema, más la amortización y el costo de capital y, si es posible, dividir dicha suma por el número de actividades realizadas para calcular el costo unitario por actividad de cibernidad.

También puede calcularse la eficiencia de la actividad de cibernidad, definida como el porcentaje de derivaciones de pacientes evitadas gracias a la utilización de la cibernidad en relación con el número total de derivaciones.

La comparación de costos y beneficios permite establecer el número mínimo de actuaciones de cibernidad (punto de equilibrio) para que el sistema sea económicamente viable y puedan evaluarse los ahorros [15].

Otra forma relativamente fácil de estimar el efecto económico se ha propuesto recientemente en Brasil [16]. El método es consecuencia de la enorme cantidad de aplicaciones de cibernidad (más de 33.000 teleconsultas y 850.000 análisis de ECG a distancia en 86 municipios durante cinco años). Los autores han tenido en cuenta tres parámetros, coste unitario variable por derivación (RVC) y distancia al punto de derivación (D): *(Nota del Traductor; el original dice "tres parámetros", pero sólo menciona dos)*

$$RVC = a \cdot D \quad (1)$$

donde "a" representa el costo por kilómetro del transporte.

Es necesario subrayar que en el análisis sólo se aplican los costos variables. La razón es sencilla, las aplicaciones de cibernidad no reducen el 100% de las derivaciones y, en consecuencia, se mantienen los costos fijos, en forma de personal y amortización, y los ahorros se basan solamente en los costos variables evitados.

El ahorro (S) de las aplicaciones de cibernidad se calcula como:

$$S = \eta \eta . RVC = \eta . a . D \quad (2)$$

donde η es la eficiencia de la actividad de cibernidad, o porcentaje de derivaciones evitadas debido a la cibernidad en relación con el número total de derivaciones. Por tanto, para que una actuación unitaria de cibernidad (UAC) sea rentable, su costo debe ser al menos igual al ahorro logrado (S), es decir,

$$UAC = \eta . a . D \quad (3)$$

En base a esta sencilla ecuación, la distancia mínima para alcanzar la rentabilidad es:

$$D_{min} = UAC / \eta . a \quad (4)$$

Si la distancia de derivación para una ciudad/ práctica médica/ municipio, calculada como media ponderada del número y distancia de las derivaciones, es mayor que D_{min} , la aplicación del sistema producirá ahorros para dicha ciudad/ práctica médica/ municipio. En base a su experiencia, los autores [16] han calculado que la distancia mínima para conseguir la viabilidad económica es de 20 km, es decir, una aplicación de cibernidad que reduzca las derivaciones de más de 20 km es económicamente viable. Asimismo, debe señalarse que conforme aumenta la eficiencia de la actividad o disminuye el costo unitario por actuación, incluso distancias menores permiten que el sistema sea económicamente razonable.

2.3.4 Conclusión

Los países en desarrollo se enfrentan a graves problemas para adaptar el sistema de atención sanitaria y garantizar un servicio de salud adecuado para todos, 24 horas al día, 7 días a la semana. La cibernidad se convierte así en una necesidad. Dado que la mayoría de los costos de la derivación de pacientes se deben al transporte, si se conoce (a) la distancia a los centros a los que se produce la derivación y (b) el número medio de pacientes derivados desde una ciudad, es posible hacer un cálculo para conocer en cada caso los parámetros económicos de la introducción de aplicaciones de cibernidad.

Referencias

- [1] Base de datos del Banco Mundial. Actualización del 23 de mayo de 2012 descargada de http://data.worldbank.org/indicador/SH.XPD.TOTL.ZS/countries?order=wbapi_data_value_2007%20wbapi_data_value%20wbapi_data_value-first&sort=asc&display=default
- [2] Whitten, P. S, Mair, F. S., Haycox, A., May, C. R, Williams, T. L, Hellmich, S. Systematic review of cost effectiveness studies of telemedicine interventions. *British Medical Journal*, 324, 2002, 1434-1437
- [3] Black A. D., Car J., Pagliari C., Anandan C., Cresswell K., et al. The Impact of eHealth on the Quality and Safety of Health Care: A Systematic Overview. *PLoS Med* 8, (1), 2011: e1000387. doi:10.1371/journal.pmed.1000387
- [4] Jacklin P., Roberts J., Wallace P., Haines A., Harrison R., Barber J. et al. The virtual outreach project group: economic evaluation of joint teleconsultations for patients referred by their general practitioner for a specialist opinion. *British Medical Journal*, 327, 2003, 84
- [5] Akematsu Y., S. Nitta, K. Morita, M. Tsuji Economics of e-Health: Measuring the Long-term Effect of Telecare, , In M. Jordanova & F. Lievens (Eds.), *Global Telemedicine/eHealth Updates: Knowledge Resources*, Publ. ISFteH, Luxemburgo, Vol. 6, 2013, 256-259
- [6] Smit, A., Scuffham, P., Wootton R. The costs and potential savings of a novel telepaediatric service in Queensland. *BioMed Centra Health Service Research*, 7 (35), 2007. Retrieved January 30, 2009 from www.biomedcentral.com/1472-6963/7/35

- [7] Al-Rousan M., Al-Ali A. R., Eberlein A. Remote patient monitoring and information system. *International Journal of Electronic Healthcare*, 2 (3), 2006, 231-249
- [8] Sel`kov A. I., Stolyar V. L., Atkov O. U., Sel`kova E. A., Chueva N. V. Telemedicine experience to serve e-clinics. In: M. Jordanova & F. Lievens (Eds.), *Electronic Proceedings Med-e-Tel 2007: The International Educational and Networking Forum for eHealth, Telemedicine and Health ICT*, Publ. Luxexpo, Luxemburgo, 2007, 211-217
- [9] Sel`kov A. I., Stolyar V. L., Atkov O. U., Sel`kova E. A., Chueva N. V. Development conception of E-Diagnosis departments of small towns and villages clinics for developing regions and countries, In: M. Jordanova & F. Lievens (Eds.), *Electronic Proceedings Med-e-Tel 2008: The International Educational and Networking Forum for eHealth, Telemedicine and Health ICT*, Publ. Luxexpo, Luxemburgo, 2008, 395-414
- [10] Figueira R. M., Alkmim M. B. M., Ribeiro A. L. P., Pena M., Campos F. E. Implementation and maintenance costs for a tele-health system in Brazil. In M. Jordanova & F. Lievens (Eds.), *Global Telemedicine/eHealth Updates: Knowledge Resources*, Publ. Luxexpo, Luxemburgo, Vol. 1, 2008, 354 -359
- [11] Bernardini A. L., Chiari G., Vanelli M. Telephone hotline service (THS) for children and adolescents with type 1 diabetes as a strategy to reduce diabetes-related emergencies and costs for admittance. In M. Jordanova & F. Lievens (Eds.), *Global Telemedicine/eHealth Updates: Knowledge Resources*, Publ. Luxexpo, Luxemburgo, Vol. 1, 2008, 26-29
- [12] Akematsu Y., Tsuji M. An empirical analysis of the reduction in medical expenditure by e-health users. *Journal of Telemedicine and Telecare*, 15, 2009, 109-111
- [13] Tsuji M., Akematsu Y. Empirical Analysis on the Reduction of Medical Expenditures by eHealth, In M. Jordanova & F. Lievens (Eds.), *Electronic Proceedings of Med-e-Tel 2012: The International eHealth, Telemedicine and Health ICT Forum for Educational, Networking and Business*, Publ. ISfTeH, Luxemburgo, 2012, 14-24
- [14] Jordanova M., Vasileva L., Vladimirov A., Gencheva A., Shtereva-Katsarova S., Krendeva B., Rasheva M., Bojinova R., Telepsychology: Lessons Learned from 4 Years of Experience, *Journal of eHealth Technology and Application*, 7 (2), 2009, 105-108
- [15] Figueira R. M., Alkmim M. B. M., Abreu M. P. et al. Operational Costs in a Large Scale Telehealth Service, In M. Jordanova & F. Lievens (Eds.), *Global Telemedicine/eHealth Updates: Knowledge Resources*, Publ. ISfTeH, Luxemburgo Vol. 4, 2011, 98 -103
- [16] Figueira R. M., Alkmim M. B. M., Abreu M. P. et al. Introducing Economical Criteria for Telehealth Implementation: An Application at the Telehealth Network of Minas Gerais, In M. Jordanova & F. Lievens (Eds.), *Global Telemedicine/eHealth Updates: Knowledge Resources*, Publ. ISfTeH, Luxemburgo Vol. 5, 2012, 184 -190

2.4 Las TIC aplicadas a la mejora de la información y la rendición de cuentas sobre la salud de la mujer y el niño

⁹ Debido a razones financieras, políticas y culturales, los cuidados sanitarios de niños y de mujeres con frecuencia se descuidan. Una amplia utilización de las TIC es una herramienta poderosa para mejorar la atención sanitaria de niños y mujeres.

La Comisión de las Naciones Unidas sobre la Información y la Rendición de Cuentas para la Salud de la Mujer y el Niño (conocida por sus siglas en inglés CoIA) ha subrayado la importancia de utilizar la cibernidad y otras herramientas innovadoras, así como los servicios de Internet, para contribuir a la mejora de la asistencia sanitaria maternal y del niño. La adopción de las TIC en el sector sanitario ha tenido un crecimiento explosivo durante los últimos años, en parte estimulada por el papel fundamental de dichas tecnologías para facilitar el acceso a una planificación familiar eficaz y la mejora de los procesos de recopilación de datos destinados a la rendición de cuentas sobre los indicadores de la CoIA.

La elevada penetración y las tasas de utilización de la radio y la televisión en los países miembros de la Comisión, incluso en comunidades aisladas y de bajos ingresos, las convierte en excelentes herramientas para la divulgación de información preventiva y para mensajes de promoción de la salud de maternal y del niño. Al mismo tiempo, un mayor acceso a otras TIC, incluida la telefonía móvil celular, los servicios de internet, la banda ancha fija y móvil, las herramientas basadas en la web y los sistemas de computación en la nube, están permitiendo a los países miembros de la Comisión establecer sistemas nacionales de información sanitaria (HIS, en sus siglas en inglés). Para promover el crecimiento de los programas sanitarios basados en la tecnología móvil para iniciativas sobre salud maternal, del lactante y del niño, y en apoyo de la estrategia mundial '*Cada mujer, cada niño*' del Secretario General, el Grupo de trabajo sobre innovación, gestionado por la Alianza mHealth, ha puesto en marcha un mecanismo catalizador de financiación, con fondos de la Agencia Noruega de Cooperación al Desarrollo (Norad) y con el apoyo técnico de la OMS.

Hasta la fecha, las subvenciones catalizadoras de la salud móvil han apoyado 16 proyectos, que se resumen más abajo en el Cuadro 1: Proyectos subvencionados actualmente por el Grupo de trabajo sobre innovación (2012 - 2014), y que están activos en 12 países en África y Asia. Estos proyectos pretenden, en conjunto, llegar a 1,5 millones de madres y niños, a 6.500 instalaciones sanitarias y a 100.000 trabajadores de la salud. Además, durante cada periodo de dos años de subvenciones, la Alianza m-Health y la OMS ofrecen oportunidades de aprendizaje colaborativo y de asistencia técnica dirigida a zonas que suponen un desafío para el crecimiento de la iniciativa, incluida la aportación de evidencias adecuadas para las partes interesadas, el desarrollo de modelos de negocio sostenibles, la creación de asociaciones público-privadas y el logro de efectos sanitarios positivos.

⁹ Hani Eskandar, Coordinador de la BDT para la C14-3/2, ITU/BDT/IEE/CYB, Suiza. Véase el documento [RGQ14.3.2-C-0022](#)

Cuadro 1: Proyectos subvencionados actualmente por el Grupo de trabajo sobre innovación (2012 - 2014)

Proyectos de la primera Ronda de subvenciones (enero 2012- diciembre 2013)	
Cell-Life – MAMA, Sudáfrica	Cell-Life utiliza el servicio SMS de MAMA para hacer llegar a madres información sobre pruebas del VIH, embarazos saludables y cuidados para la infancia, y proporciona a las madres acceso a una línea telefónica nacional de ayuda contra el SIDA. Cell-Life es una alianza con departamentos de salud locales y las ONG que pretende llegar a 38.000 madres en 2014.
“Clinton Health Access Initiative” (CHAI) – SMART, Nigeria	CHAI, el Ministerio Federal de Sanidad de Nigeria (FMOH) y la empresa Hewlett Packard se han aliado en el proyecto SMS Printers para acelerar el plazo de disponibilidad de los resultados de las pruebas diagnósticas infantiles tempranas del programa del VIH/SIDA (SMART), reduciendo el tiempo resolución de las pruebas en aproximadamente 15 días. En 2014, CHAI habrá desplegado 600 impresoras en 6 zonas geopolíticas.
Dimagi – CommCare, India	La organización Accredited Social Health Activists ha desplegado y utiliza, en asociación con Catholic Relief Services, World Vision y Real Medicine Foundation, la herramienta móvil de gestión de la salud maternal y del niño basada en fuente abierta de Dimagi para la distribución de información y servicios sanitarios en cinco provincias de la India. Para que el sistema pueda crecer, Dimagi tiene previsto el lanzamiento de la herramienta Active Data Management destinada a utilizar los datos recopilados estratégicamente para la toma de decisiones.
D-Tree International – mNUT, Zanzíbar	D-Tree International, junto con la UNICEF y el Gobierno de Zanzíbar, proporciona a trabajadores sanitarios de las provincias rurales una aplicación móvil de apoyo a la toma de decisiones que permite identificar, tratar y prestar atención a niños con malnutrición aguda. En 2014, D-Tree tiene por objetivo desplegar el sistema en los 10 distritos de Zanzíbar.
Fundación Grameen– MOTECH, Ghana	La Fundación Grameen, en asociación con el Servicio de Salud de Ghana, presta su apoyo a las mujeres de zonas rurales y a las enfermeras comunitarias mediante información específica dirigida a mujeres sobre el embarazo, los cuidados del niño y el mecanismo de citas, al tiempo que apoya los sistemas de registros electrónicos para el personal de enfermería. Grameen ha creado una asociación público-privada con MTN Ghana para ampliar sustancialmente el acceso a estos servicios.
IRD – “Interactive Alerts” para la cobertura de la vacunación, Pakistán	Interactive Research and Development (IRD) utiliza el sistema interactivo de avisos “Interactive Alerts”, un registro de vacunación electrónico, para aumentar la cobertura de la vacunación del programa ampliado de inmunización de Pakistán. Interactive Alerts proporciona mensajes SMS recordatorios a pacientes y cuidadores sanitarios, así como una identificación radioeléctrica de etiquetas para la tarjeta de inmunización y un innovador sistema de sorteo que transfiere de forma condicional dinero en metálico y que alcanza a más de 15.000 niños de la provincia de Sindh.
Ministerio de Sanidad de Rwanda RapidSMS y mUbuzima, Rwanda	El Ministerio de Sanidad de Rwanda está formando a trabajadores sanitarios de las comunidades en la utilización de aplicaciones de salud móvil para vigilar y promover la salud maternal y de lactantes, identificar riesgos potenciales y promover cuidados previos al nacimiento en las instalaciones sanitarias. Las aplicaciones de salud móvil utilizadas son “RapidSMS”, que permite un seguimiento de las mujeres embarazadas, y “mUbuzima” para recopilar e informar sobre los indicadores de los objetivos de desarrollo del milenio a nivel comunitario.
Novartis – “SMS for Life”, Camerún, Tanzania, Ghana	Novartis ha desarrollado la iniciativa “SMS for Life”, que hace un seguimiento semanal del inventario de medicamentos contra el paludismo para reducir los casos de rotura de inventarios, que está siendo desplegado en las instalaciones sanitarias de Camerún y Tanzania. En Ghana “SMS for Life” se utiliza para reducir la mortalidad en los nacimientos aportando visibilidad en tiempo real sobre las reservas de sangre en todos los hospitales de Ghana.

Proyectos de la segunda Ronda de subvenciones (enero 2013-diciembre 2014)	
Changamka Microhealth – mPowerment, Kenya	Changamka Microhealth trabaja para reducir las barreras financieras, de transporte y de conocimiento sobre los cuidados maternos y del niño mediante la oferta a las mujeres de acceso móvil a sus ahorros y seguros de salud, mensajes de información y recordatorios de citas. Actualmente se atiende a la población rural del distrito de Vihiga y Changamka y tiene por objetivo operar en <i>tres nuevos distritos del oeste de Kenya en 2015</i> .
CHAI – Apoyo a “parejas madre-hijo” mediante tecnología móvil SMS, Malawi	CHAI está utilizando el servicio de Frontline SMS para mejorar la capacidad de seguimiento de los pacientes en su modelo de atención al paciente basado en la pareja madre-hijo (MIP, “Mother-Infant Pair”), para la prevención de la transmisión del VIH de madres a hijos. En 2015, Frontline SMS brindará su apoyo a trabajadores sanitarios de las clínicas MIP en <i>seis distritos del sur de Malawi</i> .
International Institute for Communication and Development (IICD) – MAMMA, Malí y Senegal	El IID y sus asociados están formando trabajadores sanitarios comunitarios en el uso de aplicaciones móviles para mejorar la recopilación de datos geolocalizados, la coordinación logística y la comunicación clínica con el fin de mejorar la vigilancia del paludismo. Las aplicaciones también permiten a las clínicas y a las organizaciones comunitarias de salud responder más rápidamente a los brotes de paludismo. El objetivo de IICD es que en 2015 se supervise <i>una población de 200.000 habitantes en Bamako, Malí, y 100.000 habitantes en la región de Fatick, Senegal</i> .
“Malaria No More” – NightWatch, Tanzania	La iniciativa “Malaria No More” (“No más paludismo”) trabajará conjuntamente con la organización Tanzania House of Talent en el desarrollo de NightWatch: Mobile. Este programa añadirá un componente móvil interactivo a la plataforma de comunicaciones contra el paludismo NightWatch sobre la mejora y motivación del uso de mosquiteras para la prevención del paludismo en Tanzania.
Fundación Praekelt – MAMA, Sudáfrica	La Fundación Praekelt utiliza el servicio de mensajes SMS MAMA en Sudáfrica para proporcionar a las madres información de alta calidad y pertinente a nivel local sobre el embarazo y los cuidados infantiles. El servicio se ampliará para incluir un portal comunitario con funcionalidades de red social, un chat para la participación de expertos y consejeros en tiempo real, mensajería SMS adicional y un sistema interactivo de preguntas-respuestas. MAMA tiene previsto alcanzar la cifra <i>de millón de madres y de personas que toman las decisiones en el hogar en un periodo de tres años</i> .
Medic Mobile – Kujua (“To Know”), India	Medic Mobile se ha asociado con los centros de la Fundación Developmental Medical en la India para mejorar la escalabilidad y alcance de su novedosa plataforma de software PatentView, que proporciona recordatorios de vacunación y SMS a pacientes para mejorar las tasas de vacunación entre las poblaciones insuficientemente atendidas. Medi Mobile <i>tiene previsto alcanzar los 50.000 pacientes en 2015 en Delhi, Warangal, Mumbai y Hyderabad</i> .
Sociedad para la erradicación de la pobreza rural (SERP) – mNDCC, India	La Sociedad para la erradicación de la pobreza rural (SERP en sus siglas en inglés) está utilizando la aplicación mNDCC (mobile Nutrition Day Care Centers) para reforzar los servicios sanitarios y de nutrición que prestan los trabajadores sanitarios a madres y niños en zonas rurales de Andhra Pradesh, India. <i>En 2015, el uso de mNDCC se habrá ampliado su actual utilización en Andhra Pradesh de 4,200 aldeas con centros NDCC a 38,000 aldeas</i> .
VillageReach - Chipatala cha pa Foni (“Health Center by Phone”), Malawi	VillageReach ha puesto en marcha un piloto basado en la línea telefónica “Chipatala cha pa Foni,” (CCPF) para mejorar la gestión de la salud maternal e infantil y aumentar la tasa de uso de servicios e instalaciones comunitarias en zonas rurales. <i>En 2015, CCPF estará disponible para aproximadamente 400.000 mujeres y niños en 3 distritos del sureste de Malawi</i> .

Fuente: Alianza mHealth

Las intervenciones basadas en la telemedicina, los servicios de salud móvil, las líneas de emergencia gratuitas y otros canales de comunicación en tiempo casi real en diversos países miembros de la Comisión sobre la Información y la Rendición de Cuentas para la Salud de la Mujer y el Niño (CoIA), han mejorado los resultados de los sistemas de asistencia sanitaria tradicionales. En zonas conflictivas distantes y en zonas aisladas, la telemedicina abre canales de comunicación entre los trabajadores sanitarios locales y

los profesionales sanitarios y diagnosticadores del mundo exterior, logrando notables ahorros de costos y mejorando las capacidades del personal local. La adopción de las innovaciones de la ciberseguridad y de las TIC beneficia a las partes interesadas, no solo en el contexto de la iniciativa de “atención sanitaria continuada” de la OMS (“Continuum of Care”) sino también por sus efectos en todo el sector de la salud, tal como se ilustra en la figura 2 y se explica en el cuadro 2: Innovaciones en ciberseguridad y las TIC del sistema de atención sanitaria continuada (“Continuum of Care”) de la OMS.

Figura 2: Las aplicaciones de la ciberseguridad y de las TIC benefician a las diversas partes interesadas del sector de la salud

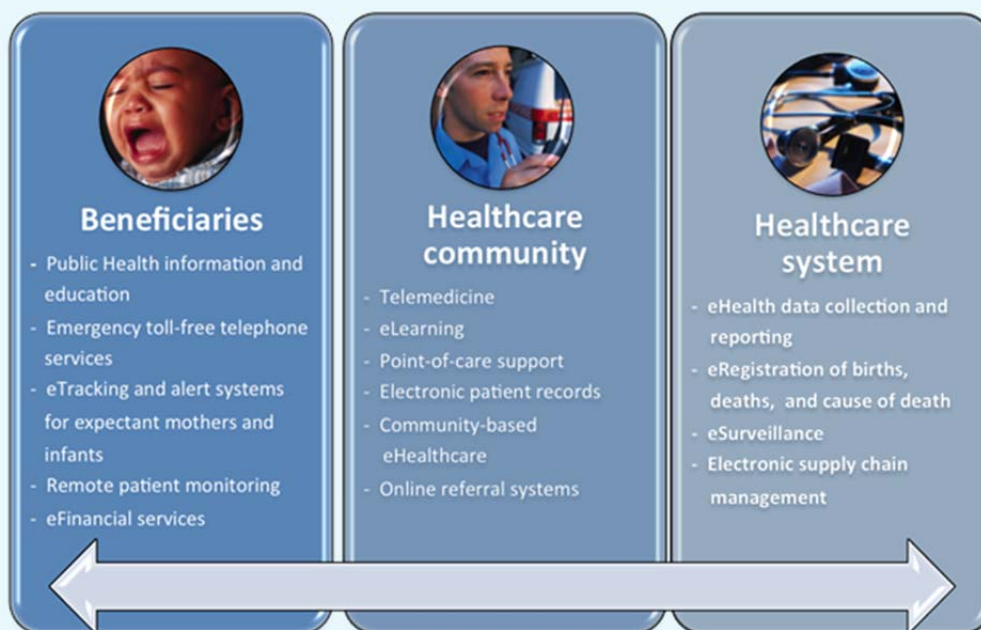

Cuadro 2: Innovaciones en ciberseguridad y las TIC del sistema de atención sanitaria continuada (“Continuum of Care”) de la OMS
A. Servicios de ciberseguridad proporcionados a individuos, madres primerizas y embarazadas, lactantes, sus familias y comunidades

Innovaciones y servicios TIC	Ejemplos de servicios TIC de la atención sanitaria continuada de la OMS				Ejemplos de proyectos de ciberseguridad en países del CoIA ¹⁰
	Pre-embarazo	Embarazo	Nacimiento	Post-parto	
Información y educación sanitaria pública <ul style="list-style-type: none"> Centros de llamadas y líneas de ayuda Radio local Educación y promoción de educación sanitaria basada en SMS/IVR SMS y redes sociales para cambios de comportamientos y comunicación 	Acceso a información sanitaria sobre reproducción Refuerzo del cambio positivo en el comportamiento sobre la salud, por ejemplo, tiempo entre embarazos Estimulo a la demanda de atención sanitaria sobre reproducción	Consejos sobre cuidados adecuados e información general sobre el embarazo Apoyo a la prevención y tratamiento de la transmisión madre-hijo del VIH-SIDA y otras enfermedades contagiosas. Establecer redes de apoyo mutuo entre mujeres embarazadas Mejorar el acceso y utilización de los servicios de salud maternal por las mujeres embarazadas	Incentivos para que las mujeres acudan a instalaciones con cuidados especializados durante y después del parto	Acceso a información sobre nutrición de lactantes y niños, agua potable segura, promoción de la higiene, etc.	<ul style="list-style-type: none"> MAMA [2] Text4Baby [40] Medic Mobile [13] UNICEF Reminder Mother System [42]
Servicios telefónicos con números gratuitos para emergencias			Mejorar el transporte de mujeres embarazadas y de recién nacidos con complicaciones Acceder a atención profesional en el parto en caso de emergencia obstétrica	HealthLine [26]	<ul style="list-style-type: none"> HealthLine [26]
Sistemas de seguimiento electrónico y de alertas para mujeres embarazadas y lactantes <ul style="list-style-type: none"> Inscripción del paciente Cumplimiento del tratamiento Recordatorios de citas 	Consejos prenatales en todas las fases de la gestación Recordatorios a mujeres embarazadas de las citas prenatales, informando a las enfermeras del seguimiento			Inscripción del lactante para la inmunización Recordatorios a las madres que requieran cuidados postnatales para ellas y sus lactantes Alertas de vacunación de lactantes	<ul style="list-style-type: none"> M-Chanjo [12] MoTech [32] CommCare [21]
Directorios electrónicos de prestadores de asistencia sanitaria <ul style="list-style-type: none"> Base de datos de hospitales y clínicas Base de datos de profesionales sanitarios 	Mejorar el acceso rápido a los servicios de salud a través de la iniciativa “atención sanitaria continuada” de la OMS				<ul style="list-style-type: none"> Hospitalsworldwide.com www.hospitalsworldwide.com/ OBGYN.net www.obgyn.net/
Telesupervisión de pacientes		Detección y vigilancia ante la aparición de señales de alerta y síntomas típicos de embarazos de alto riesgo Pagos por la atención sanitaria previa al parto, por ejemplo, consultas, diagnósticos, pruebas de laboratorio, etc.		Cuidados y tratamiento en el hogar de recién nacidos con complicaciones	<ul style="list-style-type: none"> Amanece [16] RapidSMS [35]
Servicios financieros electrónicos	Permitir el ahorro de las mujeres para el parto y cuidados posteriores		Pagos por la atención médica del parto, por ejemplo, transporte y atención hospitalaria	Pagos de cuidados postparto, por ejemplo, inmunizaciones del niño.	<ul style="list-style-type: none"> Health System 20/20 [27] Changamka Medical Smart Card [20]

¹⁰ Los proyectos de ciberseguridad enumerados en este cuadro se describen con más detalle en el Anexo III. El número entre corchetes corresponde al número de proyecto que figura en el Anexo III.

B. Servicios de ciberseguridad proporcionados a prestadores de atención sanitaria, centros sanitarios, profesionales sanitarios, médicos, enfermeras y matronas, así como trabajadores comunitarios de la salud

Ejemplos de servicios TIC de la atención sanitaria continuada de la OMS					Ejemplos de proyectos de ciberseguridad en países del CoIA
Innovaciones y servicios TIC	Pre-embarazo	Embarazo	Parto	Postparto	
Telemedicina <ul style="list-style-type: none"> • Audio y video conferencia • Soluciones de teleultrasonografía, telecardiología, etc. • Telediagnósticos 	Detección y vigilancia ante la aparición de señales de alerta y síntomas típicos de embarazos de alto riesgo Tele-examen obstétrico mediante ultrasonidos	Acceso a profesionales médicos en caso de emergencia	Supervisión/prueba sobre el VIH, sífilis y otras enfermedades Aceleración del envío de resultados de las pruebas para un diagnóstico temprano del lactante	<ul style="list-style-type: none"> • CliniPak [22] • SMART [38] • TulaSalud [41] • RAFT [34] 	
Ciberaprendizaje <ul style="list-style-type: none"> • Materiales de formación en línea • Preguntas-respuestas con SMS • Formación mediante SMS/MMS/IVR 	Formación sanitaria del trabajador comunitario de la salud (TCS) sobre salud reproductiva	Formación sanitaria del TCS sobre el embarazo y el parto	Formación de las asistentes tradicionales del parto	Formación del TCS sobre cuidados a recién nacidos y en la infancia temprana	<ul style="list-style-type: none"> • AMREF www.amref.org/
Apoyo al punto de atención sanitaria <ul style="list-style-type: none"> • Sistemas de apoyo a las decisiones (por ejemplo, listas de verificación y algoritmos) 	Vigilancia de los factores de riesgo del embarazo Mejora de la eficiencia en el diagnóstico y tratamiento de la atención continuada mediante cuidados protocolizados			Gestión integrada de las enfermedades de la infancia en niños menores de 5 años	<ul style="list-style-type: none"> • E-IMCI utilizando D-Tree [10] • SMART [38]
Registros electrónicos de los pacientes <ul style="list-style-type: none"> • EHR, EMR, PHR 	Integración sin solución de continuidad de los datos de historias de pacientes durante la atención sanitaria continuada				
Ciberseguridad a nivel comunitario	Recopilación de datos rutinarios de pacientes en las visitas al hogar y en la clínica para el seguimiento de los indicadores de salud a nivel de comunidad Gestión de casos concretos Información y seguimiento de la salud de las embarazadas y los recién nacidos y envío de alertas en casos de anomalías Gestión de los empleados y supervisión del rendimiento e incentivos Mejora del flujo de información hacia la comunidad Mejora de la comunicación y de conocimientos médicos entre las instituciones de atención sanitaria y quienes atienden los partos				<ul style="list-style-type: none"> • Childcount+ [8] • CommCare [21] • Pesinet [33] • Aceh Besar midwives [6]
Sistemas de derivación de pacientes <ul style="list-style-type: none"> • Red privada • Servicios en línea o SMS 				Derivación y transporte de embarazadas o de recién nacidos con complicaciones a instalaciones con los recursos adecuados Acceso a una atención especializada en el momento del parto	<ul style="list-style-type: none"> • SHINE [37] • EhealthPoint [23]

C. Servicios de ciberseguridad prestados a gestores y administradores de la atención sanitaria para fortalecer los sistemas de salud

Innovaciones y servicios TIC	Ejemplos de servicios TIC de la atención sanitaria continuada de la OMS				Ejemplos de proyectos de ciberseguridad en países CoLA
	Pre-embarazo	Embarazo	Parto	Postparto	
Recopilación e información de datos sanitarios por medios electrónicos <ul style="list-style-type: none"> Sistema en línea de información sanitaria Formularios de recopilación de datos mediante SMS o datos móviles 	Recopilación, agregación y análisis de datos sanitarios sobre la demanda de planificación familiar	Recopilación, agregación y análisis de datos sanitarios sobre la distribución del VIH-ARV entre mujeres embarazadas y visitas para la atención previa al parto	Recopilación, agregación y análisis de datos sanitarios sobre la atención profesional en partos, así como sobre cuidados postparto de madres y lactantes dos días después del parto	Recopilación, agregación y análisis de datos sanitarios sobre la alimentación sólo mediante lactancia, inmunización, tratamiento con antibióticos de la neumonía infantil y prevalencia del retraso del crecimiento	<ul style="list-style-type: none"> Información en línea del National Rural Health Mission, Punjab, India www.pbnrhm.orh/online_reporting.aspx
Inscripción electrónica de nacimientos, fallecimientos y causa del fallecimiento			Inscripción de nacimientos, defunciones y causas de éstas		<ul style="list-style-type: none"> e-District Kapurthala, India [1]
Cibervigilancia			Notificación de la defunción de la madre o del recién nacido, análisis y vigilancia	Vigilancia de la salud materna e infantil en relación con la meningitis, el paludismo, la diarrea o la nutrición.	<ul style="list-style-type: none"> Project Mwana [4] mCare [1.1]
Gestión electrónica de la cadena de suministro	Gestión de inventarios para productos de salud sobre la reproducción	Gestión de inventarios de productos que salvan vidas ¹¹	Gestión de inventarios de productos que salvan vidas	Gestión de inventarios de productos para vacunas, neumonía, diarrea, drogas, etc.	<ul style="list-style-type: none"> SMS for Life www.rbm.who.int/

¹¹ www.everwomaneverychild.org/resources/un-commission-on-life-saving-commodities/life-saving-commodities

3 De país en desarrollo a país en desarrollo – Lecciones aprendidas de la ejecución de prácticas idóneas

En este capítulo se presenta información resumida sobre modelos de funcionamiento de servicios de ciberseguridad desarrollados y puestos en marcha (o en proceso de ejecución) en algunos países en desarrollo. Pueden servir como “prácticas idóneas” para otros, cuyas iniciativas no deben partir de cero.



3.1 Ejemplos de prácticas idóneas de Estados Miembros de la C14-3/2

Además de la información del cuadro 2, en el Anexo a este informe se incluyen descripciones más amplias de los logros en materia de ciberseguridad de algunos países. En el cuadro 3 se resumen algunos de los logros. Se recomienda la lectura de los textos completos.

Cuadro 3: Ejemplos de prácticas idóneas de Estados Miembros

Dónde	Qué	Áreas
Argentina	Amplia gama de servicios de ciberseguridad Experiencia en la aplicación de software gratuito de fuente abierta	Red nacional de telepediatría Registros sanitarios electrónicos Segundas opiniones médicas Software de fuente abierta para formación y teleconsultas sincronizadas, que también permite la transmisión de intervenciones quirúrgicas y de ultrasonidos; Telesupervisión de postoperatorios de pacientes >5.000 aplicaciones sobre la salud para distintos modelos de teléfonos inteligentes
Côte d'Ivoire	Cibereducación	Formación de jóvenes investigadores en centros de investigación y universidades públicas. Apoyo a la rehabilitación de puestos de atención y de laboratorios, a capacidades (equipos y conectividad) y al acceso a información científica.
Guinea	Servicios en línea, Ciberseguridad, Cibereducación	Forma parte de la Red Panafricana que conecta a los 53 miembros de la Unión Africana cuyo objetivo es lograr una comunicación y conectividad eficaz entre los estados de la Unión. Logros: Proyecto de cibereducación: al 95% Proyecto de ciberseguridad, definición y fase de instalación: al 90%
India	Todos los aspectos de la ciberseguridad	Registros médicos electrónicos y automatización de hospitales Amplia gama de servicios de telemedicina y ciberaprendizaje Creación de una bibliografía en línea de acceso abierto Medidas exitosas de normalización y legislación en materia de telemedicina Conjunto de herramientas sobre salud móvil
Indonesia	Teleradiología y Telediagnóstico	Sistema disponible de archivo y transferencia de imágenes médicas con gran capacidad de almacenamiento, una relación de compresión efectiva de 16:1 manteniendo la calidad de la imagen reconstruida Campo de visión automático de bajo costo Microscopio de exploración para sistemas de detección temprana de la tuberculosis



Dónde	Qué	Áreas	
Japón	Maletín electrónico del doctor	Transmite fácilmente información biológica del paciente con imágenes de alta definición en un entorno con disponibilidad de comunicaciones móviles	
Japón	Electrocardiógrafo multifuncional "Radarcirc"	Sistema móvil de telemedicina para transmisión en tiempo real de datos de un ECG de 12 derivaciones y video desde una ambulancia desplazándose al hospital. El sistema permite la medición, análisis y transmisión de datos de electrocardiogramas de 12 derivaciones incluso en caso de artefactos de movimiento graves y durante una reanimación cardiopulmonar.	
República Kirguisa	Telecardiología, cuidados sanitarios de la madre y el niño	Apoyo médico 24/7/365 ON-OFF a las regiones más remotas del país desde centros sanitarios nacionales con personal médico profesional muy cualificado. Formación del personal médico en tecnologías de la información y otros aspectos profesionales	
Lao (República Democrática Popular)	Ampliación de la red de cibergobierno con la ciberseguridad	Teleconsultas entre el Hospital Central y los hospitales provinciales Cibereducación para médicos, enfermeras y otro personal sanitario	
Líbano	Aplicación de salud móvil pública	Las aplicaciones incluyen: - Lista de medicamentos (verificación del precio, dosificación, formato, legalización...) - Directorio de hospitales públicos y privados y de centros de atención primaria - Servicios y campañas del Ministerio de Sanidad - Consejos sobre estilos de vida y hábitos saludables, etc.	
Malí	Proyectos piloto de ciberseguridad en todos los niveles de la pirámide sanitaria	Teletratamiento – flota móvil (500 teléfonos móviles para trabajadores sanitarios del nivel periférico) para la prestación de servicios de salud, centrados en niños de menos de cinco años y en madres. Ciberaprendizaje y tele-educación mediante portales web dinámicos	Responsable – Organización nacional para la ciberseguridad y la informática sanitaria
Pakistán	Red de teleconsulta mediante conectividad satelital Telemedicina para emergencias	Teleconsulta de radiología, cirugía, medicina interna, cardiología, otorrinolaringología, dermatología, psiquiatría y ortopedia; Ciberaprendizaje – centro de formación para médicos y enfermeras	
Panamá	Tecnología de generación y ciberservicios para una inclusión digital accesible y sostenible – Proyecto LUCY	Garantiza que cualquiera que se enfrente a barreras de accesibilidad debido a discapacidad, alfabetización o edad, pueda acceder y utilizar, con independencia de sus recursos económicos, Internet y toda su información, las comunidades y servicios para la educación, el empleo, la vida cotidiana, la participación civil y la seguridad.	www.lucytech.com
Tanzanía	Teleconsultas y Tele-educación	Basada en la infraestructura troncal nacional de fibra óptica que conecta todas las regiones del país.	Comité nacional de ciberseguridad para la armonización de

Dónde	Qué	Áreas	
		Consultas mediante teléfonos móviles o internet. Videoconferencia: presentación de casos clínicos, educación médica continua en patología clínica.	iniciativas en telemedicina
Turquía	Aplicación de la cibernidad mediante la colaboración exitosa entre operadores de telecomunicaciones, hospitales y empresas de software	Servicios disponibles en régimen 7/24 – información sobre farmacias de guardia, consultas sanitarias, acceso gratuito a ambulancias completamente equipadas cuando sean necesarias, seguro médico. Implementación de un sistema de información integrado de gestión sanitaria.	
Uzbekistán	Implementación de sistemas de información de gestión sanitaria	Mejora del acceso a datos administrativos, clínicos y epidemiológicos; funcionamiento más eficaz de las organizaciones y prestadores de servicios sanitarios.	Responsable – Ministerio de Sanidad
Zambia	Aplicaciones de salud móvil	Basado en un esquema de fuente abierta gratuita; diagnóstico temprano de lactantes (resultados de pruebas de GSS del VIH) y seguimiento de pacientes para cuidados postparto, mejora de las comunicaciones entre prestadores de atención sanitaria	Responsable – Ministerio de Sanidad

3.2 Apoyo entre países para la formación en cibernidad: 10 años de experiencia de la UIT en formación médica de corta duración

¹² La Universidad de Tokai (Japón) y la UIT/BDT (Oficina de Desarrollo de las Telecomunicaciones) ha elaborado un curso de formación para médicos y trabajadores de atención sanitaria de países en desarrollo para que entiendan cabalmente las tendencias y tecnologías actuales en telemedicina y cibernidad, y proporcionar así las bases para la introducción de servicios de telemedicina en dichos países.

La Universidad de Tokai organiza el curso con el apoyo financiero de la Agencia Japonesa de Colaboración Internacional (JICA) y la Fundación Sasakawa para la Paz. Los participantes se benefician de la experiencia e instalaciones de la Universidad de Tokai, que es un agente activo a nivel internacional en telemedicina y cibernidad, y tiene experiencia en proyectos piloto de la UIT/BDT. Existen dos tipos de programas:

- Programas de formación postdoctoral de larga duración
- Programas de formación de corta duración

Desde 2002 diez participantes han asistido al programa de formación postdoctoral (uno de Buthan, uno de Haití, cuatro de Indonesia, uno de China, dos de Paquistán y uno de Paraguay). El programa consta de cuatro bloques:

- Divulgación de la investigación y realizaciones en telemedicina;
- Avances en equipamientos de cibernidad y compartición con otros países de la experiencia de Japón en el desarrollo y despliegue de cibernidad;
- Mejora y exploración de las posibilidades de investigación relativas a la telemedicina;

¹² Contributor: Yuichi Ishibashi, Tokai University School of Medicine, Japan. See document [RGQ14.3.2-INF-0022](#)

- Mejora de la administración y la gestión mediante la especificación e implementación de aplicaciones de ciberseguridad.

Se ha elaborado un programa de corta duración dirigido a los países insulares del Pacífico apoyado por la Fundación Sasakawa para la Paz. Antes del inicio del curso, los profesores visitaron las islas para entrevistar a potenciales candidatos, evaluar sus motivaciones y conocimientos básicos y seleccionar a los candidatos idóneos. Tras su llegada a Japón, los estudiantes se alojaron en la residencia de la universidad de Tokai para estudiantes extranjeros y realizaron el programa en el Campus de Shonan de la Universidad de Tokai durante tres meses. El proceso de aprendizaje ha utilizado dos enfoques: el método de clases y ejercicios prácticos sobre el contenido principal, y el método de clases y ejercicios de demostración. Antes de cada ejercicio se impartieron las correspondientes clases. El método de ejercicios prácticos con prueba y error es importante porque permite a los alumnos adquirir y desarrollar una sólida comprensión del material del curso. Por tanto, los ejercicios prácticos personales se realizan tantas veces como sea necesario para consolidar los conocimientos de los participantes. A cada alumno se le facilitó una computadora personal, software y conexión a internet.

Contenido de la formación

El programa del curso está basado en la experiencia de cursos de apoyo previos, como los celebrados en Bután y Bangladesh. Se han utilizado varias aplicaciones (software) y equipos (hardware). En relación con el software, se hizo hincapié en la recopilación, análisis y compartición de la información. En relación con el hardware, la práctica médica sobre el terreno precisa de sensores y equipos para realizar electrocardiogramas (ECG), siendo necesario que los países insulares desplieguen redes de área local inalámbricas.

Es difícil que en un periodo de tres meses puedan adquirirse los conocimientos técnicos necesarios para desarrollar sistemas prácticos de ciberseguridad. En consecuencia, se hizo hincapié en describir una amplia gama de tecnologías disponibles para poder realizar la selección de las más adecuadas según las particularidades de los países de los participantes.

En las clases sobre software, se estudiaron especialmente los sistemas de bases de datos y los sistemas de información geográfica (GIS). El informe de 2005 del Observatorio Mundial de Ciberseguridad de la OMS describe diez herramientas para la ciberseguridad, una de ellas es la telesalud y otra los GIS, éstos últimos con importancia desde el punto de vista epidemiológico. Durante las clases se dedicó el tiempo necesario para el conocimiento y estudio del software de bases de datos y de GIS, por su utilidad en la prevención de epidemias y en la gestión de enfermedades en regiones muy extensas, así como por la importancia del análisis de la información almacenada en bases de datos. Los alumnos aprendieron a utilizar los programas ACCESS de Microsoft y ArkGIS y desarrollaron un sistema sencillo que almacena y muestra gráficamente la información médica de sus países contenida en la base de datos. El sistema a desarrollar en la práctica debería estar basado en una aplicación web. Por tanto, es importante que la información se organice y represente adaptada a dicho tipo de sistema, por lo que los alumnos también deben tener conocimientos necesarios sobre la organización y representación de información en la web. En el Cuadro 4 se describe someramente el contenido del programa.

Entre los países insulares del Pacífico se dan situaciones distintas. Por ejemplo, en Fiji es necesaria la colaboración entre las dos islas mayores y el resto de islas más pequeñas. La población es grande y existe un número relativamente alto de trabajadores de la salud. La ciberseguridad aplicada en el hogar es importante. En Nauru, aproximadamente 10.000 personas viven en una isla con pocos trabajadores sanitarios. Es necesario analizar la colaboración en materia de ciberseguridad entre Nauru y países desarrollados, como por ejemplo Australia.

Los alumnos asimilaban el contenido de las lecciones, analizaron la aplicación de las tecnologías en sus respectivos países y escribieron informes sobre las prácticas realizadas tras las lecciones. A los países originarios de los alumnos les resulta difícil introducir tecnologías de ciberseguridad utilizando exclusivamente sus propios presupuestos. Es preciso que reciban apoyo tecnológico y económico de países desarrollados. Se confía en que las ideas reflejadas en los informes de los alumnos puedan alentar

al gobierno japonés a ofrecer su apoyo, por ejemplo, a través de la Agencia Japonesa de Colaboración Internacional (JICA).

Resultados

A lo largo de tres años se ha consolidado un curso con un programa bien estructurado que cuenta con los materiales y textos adecuados. Además del programa, existen otros aspectos a tener en cuenta para garantizar que el curso rinda beneficios prácticos. En este sentido, debe señalarse que la carencia de infraestructuras TIC, típica de países en desarrollo, es una barrera para la aplicación práctica de este y de otros cursos similares, por lo que resulta muy recomendable que organizaciones conexas contribuyan a la continuidad ulterior del programa mediante la ayuda al despliegue de infraestructuras TIC.

Cuadro 4: Programa

Clasificación	Áreas tratadas	Temas
Software	Recopilación, almacenaje, análisis y representación de la información	Producción de imágenes estáticas y en movimiento Análisis de datos con las aplicaciones R y MATLAB Uso de la base de datos ACCESS Programa multimedia interactivos para cibernidad (HTML) Sistema de Información geográfica ArcGIS
Hardware	Comunicación y sensores	Comunicación Sensores LAN inalámbrica
Otros asuntos	Sistemas existentes sobre cibernidad y la ayuda internacional	Telecardiología en Buthan Sistema de teleconferencia Tendencias en cibernidad según la OMS y la UIT Fondo del servicio universal para la cibernidad Organización de la "Ayuda Oficial al Desarrollo (ODA)" del gobierno Japonés

Los países insulares del Pacífico tienen características específicas, tales como una población distribuida en islas dispersas y recursos limitados. Dichos países tienen el problema común de unos recursos muy limitados para la creación de redes y servicios TIC que permitan aumentar la calidad de la atención sanitaria. Los prestadores de cuidados sanitarios en las islas necesitan fondos para la planificación y ejecución de redes y aplicaciones TIC, así como para la formación en las TIC de médicos, enfermeras y personal hospitalario.

Creemos que el curso de formación descrito ha logrado el objetivo de desarrollo de recursos humanos, aunque lo haya hecho parcialmente, pues sólo han podido asistir seis personas en tres años. Esperamos que el proyecto se amplíe y tenga continuidad durante un periodo de tiempo prolongado. Aunque las circunstancias médicas de los países presentan problemas comunes, también existen aspectos muy específicos. Por ejemplo, Fiji y las Islas Cook se caracterizan por ser archipiélagos con muchas islas dispersas para las que el establecimiento de redes entre islas es importante. Por el contrario, Nauru se compone de una única isla, con una circunferencia de 18 km, y muy pocos médicos; Nauru necesita el establecimiento de consultas de médicos con experiencia procedentes de otros países. Este curso ha permitido conocer la situación de las islas del Pacífico en el ámbito sanitario, así como obtener información que para analizar la situación e identificar propuestas de mejora.

Referencias

- [1] Usman K, et.al. Web-Based and Geographical Information System of Health and Medical Content for Developing Nation(Fiji e-Health Training Program), Journal of e-Health Technology and Application, Volume 5, No. 1, 2007: 46-50
- [2] Kinoue T, et.al. E-Health Expert Training Course Hosted at Tokai University. World Telecommunication Development Conference (WTDC 02), 2002, Estambul; INF3-E:1-2

- [3] Androuchko L, Nakajima I. Developing Countries and e-Health Services, 6th International Workshop on Enterprise Networking and Computing in Healthcare Industry, Healthcom 2004, Odawara: 211-214
- [4] Kinoue T, et.al. Project for Training of Future Health Leaders around the World, Especially in the Asia-Pacific Region, Report of 2003 Activity, 2nd APT Telemedicine Workshop 2004, Nueva Delhi, India: 95-97
- [5] Sadique M A, et al. A Study on Pacific Island e-Health projects and our support, 8th International Conference on e-Health Networking, Application and Services, Healthcom 2006, Nueva Delhi, India: 250-253
- [6] Ishibashi Y, et.al. Training Program for e-Health in Tokai University, Healthcom 2008, Singapur: 121-124

4 Conclusiones y recomendaciones

La cibernidad es necesaria y no tiene marcha atrás. Constituye un reto formidable para el futuro que precisa de colaboración y coordinación a todos los niveles, conexión entre las partes involucradas y planificación, partir de una disposición positiva a aprender de la experiencia ajena y aprovechar el trabajo ya realizado para no “inventar la rueda”.

En base a su dilatada experiencia, la UIT, y en particular la Cuestión 14-3/2, ha subrayado siempre algunos de los prerrequisitos más importantes para la aplicación exitosa de la cibernidad:

- Debe realizarse un análisis preliminar cuidadoso de las necesidades y la infraestructura disponible, ya que cada región o cada país tiene necesidades diferentes, una organización y administración sanitaria específica y sus propias expectativas, entre otras;
- El proyecto más cuidadosamente elaborado puede resultar completamente inviable si no se tienen en cuenta las tradiciones y características culturales locales;
- Es muy recomendable la participación de líderes de opinión locales/nacionales;
- Una condición para el éxito es preservar el sistema sanitario existente, no destruirlo;
- Un enfoque basado en la imitación de otros casos no es la mejor forma de abordar la cuestión: soluciones ampliamente utilizadas en países desarrollados no siempre son las que los países en desarrollo desean implantar;
- Es vital mantener contactos entre los responsables de distintos países. El conocimiento de las tendencias globales en materia de cibernidad ayuda a los profesionales a:
 - crear un mismo nivel de conocimientos y una atmósfera de entendimiento, que además contribuye a influir en el ámbito político local responsable de la integración de la cibernidad en la atención sanitaria;
 - generar la necesaria sensibilización pública sobre la cibernidad y su potencialidad;
 - mantener un diálogo constructivo e inteligente, y crear un consenso entre las partes interesadas sobre principios, políticas y estrategias para que la aplicación de la cibernidad sea tecnológicamente adecuada y culturalmente sensible.

El papel desempeñado por la Cuestión 14-3/2 es muy valioso por su capacidad y disposición para proporcionar experiencia y consejos útiles, así como para movilizar recursos y validar la fiabilidad y eficacia de la cibernidad, donde y cuando sea necesaria.

En base a la experiencia acumulada por la C14-3/2, se considera que las recomendaciones siguientes constituyen una orientación fundamental para los responsables políticos y de la toma de decisiones sobre la atención sanitaria en los países en desarrollo.

4.1 Recomendaciones de la C14-3/2-2013

Actualmente, todos los países en desarrollo están sensibilizados en relación con las soluciones y servicios que ofrece la ciberseguridad, pero es necesaria la adopción de medidas para la puesta en práctica de dichas tecnologías avanzadas al servicio de los ciudadanos:

- ¹³ Acelerar las medidas necesarias para incrementar la sensibilización de los responsables políticos, reguladores, operadores de telecomunicación, donantes y clientes sobre el papel de las tecnologías de la información y la comunicación en la mejora del acceso a los servicios de atención sanitaria en los países en desarrollo.
- Alentar la colaboración y el compromiso entre el sector de las telecomunicaciones y el sector sanitario para maximizar la utilización de los recursos limitados de ambos con vistas a poner en marcha servicios y soluciones de la ciberseguridad en la práctica médica.
- Facilitar oportunidades para el establecimiento de contactos y para la transferencia de conocimientos en el campo de la ciberseguridad (parte técnica).
- Impartir programas de educación sobre el alcance de la ciberseguridad y sobre futuras medidas para un mejor acceso a la atención sanitaria, tendencias y tecnologías más recientes, etc.
- Promover el conocimiento básico de la ciberseguridad entre toda las partes interesadas, incluidos los ciudadanos en general.
- Fomentar las innovaciones utilizadas en diversos contextos de la atención sanitaria.
- Propiciar la mejor utilización posible de la tecnología de la comunicación, con un mayor énfasis en que todas las partes interesadas utilicen dicha comunicación. La función subyacente de la atención sanitaria es la comunicación. Los pacientes comunican los síntomas y los prestadores de servicios sanitarios comunican los tratamientos.
- Alentar la participación del personal médico en las actividades de la UIT sobre ciberseguridad/sanidad móvil.
- Divulgar activamente las experiencias y prácticas idóneas sobre la utilización de tecnologías de la información y las telecomunicaciones en la ciberseguridad y la sanidad móvil en países en desarrollo, basada en sistemas fáciles de utilizar, fiables, de bajo costo y energéticamente eficientes, que utilicen, por ejemplo, la tecnología más moderna de circuitos integrados.
- Seguir creando redes de expertos para una labor de coordinación con los avances en tecnologías y aplicaciones de la ciberseguridad y sanidad móvil y acelerar su implantación en países en desarrollo.
- Identificar las distintas tecnologías utilizadas en el desarrollo de soluciones de ciberseguridad y sanidad móvil, y preparar un compendio de plataformas técnicas de ciberseguridad y sanidad móvil existentes para los distintos servicios sanitarios, teniendo en cuenta las redes de telecomunicación existentes en los países en desarrollo.
- Desarrollar criterios de evaluación de proyectos y servicios de ciberseguridad con atención prioritaria a la tecnología utilizada y la calidad de los servicios en los países en desarrollo.
- Promover activamente la elaboración de normas técnicas para las aplicaciones de ciberseguridad y sanidad móvil conjuntamente con el UIT-T y, en particular, de directrices para los países en desarrollo sobre cómo aplicar dichas normas y recomendaciones.

¹³ L. Androuchko¹, I. Nakajima², M. Jordanova³, 1 International University in Geneva, Dominic Foundation, Suiza, Relator, Cuestión 14 -3/2– La información y las telecomunicaciones para la ciberseguridad.

- Prestar la atención debida a la evaluación económica de proyectos piloto de ciberseguridad y salud móvil en países en desarrollo, instando al sector privado a participar en el despliegue de la ciberseguridad y la salud móvil.
- Fomentar la alfabetización en materia de ciberseguridad/salud móvil de todas las partes interesadas, mediante la su participación en talleres y seminarios de la BDT.
- Finalmente, la Comisión de Estudio 2 del UIT-D, responsable de la Cuestión 14-3/2, recomienda firmemente a los responsables políticos de los países en desarrollo que utilicen, cuando proceda, el Conjunto de herramientas sobre aspectos nacionales de la ciberseguridad preparado por la UIT y la OMS.

4.2 Conjunto de Herramientas de la UIT y la OMS de la Estrategia Nacional de Ciberseguridad

¹⁴Necesidad de planificación nacional

La experiencia ha demostrado que la utilización de las TIC en la salud exige una actuación estratégica a nivel nacional para utilizar de la mejor forma posible las capacidades existentes y proporcionar una base firme para la inversión y la innovación. El establecimiento de directrices principales así como la planificación detallada de las medidas necesarias, son actividades esenciales para lograr objetivos a largo plazo tales como la eficiencia del sector de la salud, su reforma o una transformación más profunda del mismo. Un aspecto fundamental de este esfuerzo es la colaboración entre los sectores de la salud y de las TIC tanto en la esfera pública como en la privada. En su papel de organizaciones responsables en el sistema de las Naciones Unidas de la salud y de las telecomunicaciones, respectivamente, la Organización Mundial de la Salud (OMS) y la Unión Internacional de Telecomunicaciones (UIT) han reconocido la importancia de la colaboración en la esfera de la ciberseguridad en sus resoluciones a nivel mundial, que alientan a los países a desarrollar estrategias nacionales de ciberseguridad. Este Conjunto de Herramientas apoya dichas recomendaciones.

Los ministerios de salud juegan un papel central, no solo para satisfacer las necesidades de atención y protección sanitaria de las personas, sino también para preservar los sistemas sanitarios en épocas de incertidumbre. Los ministerios de tecnologías de la información y de las telecomunicaciones son fundamentales para el desarrollo en todas las esferas y pueden hacer una contribución vital al sector de la salud. La existencia de objetivos comunes y un entorno predecible para las TIC permite una actuación coordinada: la creación de consenso en aspectos políticos, un mejor uso de los recursos compartidos y la participación del sector privado, así como inversiones en conocimiento e infraestructuras que mejoren los resultados en materia de salud.

Objetivo y audiencia

El Conjunto de Herramientas de la Estrategia Nacional de Ciberseguridad es un recurso disponible para desarrollar o revitalizar la estrategia de ciberseguridad de un país, y es aplicable tanto para países en fase de elaboración de sus planes como para países que han realizado inversiones significativas en ciberseguridad. Por tanto, es de utilidad para países que desean iniciar su actividad a partir de los resultados prometedores de experiencias piloto realizadas, países que desean establecer las bases para el crecimiento de sus proyectos de ciberseguridad y países que desean actualizar su estrategia para reflejar circunstancias cambiantes. El Conjunto de Herramientas puede ser utilizado por responsables sanitarios de los ministerios de los gobiernos y por departamentos u organismos que gestionan el desarrollo de la estrategia de ciberseguridad. Su aplicación requiere que exista un equipo con experiencia en planificación estratégica, análisis, comunicación y que cuente con la participación de las partes interesadas.

¹⁴ Hani Eskanar, Coordinador de la BDT para la Cuestión 14-3/2, ITU/BDT/IEE/CYB. Véase el documento [SG02-C-0182](#)

Figure 3: Conjunto de herramientas para elaborar una estrategia nacional de ciberseguridad



Visión general del Conjunto de Herramientas

El Conjunto de Herramientas consta de tres partes, cada una construida en base a la anterior:

- Parte 1: Desarrolla una visión nacional de la ciberseguridad que responde a objetivos sanitarios y de desarrollo. Explica por qué es necesario un enfoque nacional, los objetivos del plan y cómo debe ejecutarse.
- Parte 2: Desarrolla una hoja de ruta de la ejecución que refleje las prioridades del país y el contexto de la ciberseguridad. Estructura actividades a medio plazo y crea los cimientos para el largo plazo.
- Parte 3: Establece un plan para supervisar la ejecución y gestionar los riesgos asociados. Refleja los avances y resultados de la ejecución y contribuye a garantizar el apoyo y las inversiones a largo plazo.

En cada sección se describen las actividades necesarias, junto a consejos prácticos basados en la experiencia acumulada.

Los países pueden acometer todo el conjunto de actividades o aquellas específicas a su contexto y que tengan en cuenta sus limitaciones. La forma de utilizar el Conjunto de Herramientas y los resultados finales dependerán del contexto del país, las prioridades y la visión.

El Conjunto de Herramientas está disponible en: www.itu.int/ITU-D/cyb/app/e-health.html and www.who.int/ehealth

Annexes

- Annex I: Case Studies: Lessons Learned from e-Health Implementation**
- Annex II: Lessons Learned from e-Health Implementation: Knowledge**
- Annex III: Compendium of e-Health projects for RMNCH implemented in CoIA countries**
- Annex IV: Composition of the Rapporteur Group for Question 14-3/2**
- Annex V: Glossary**

Annex I: Case Studies: Lessons Learned from e-Health Implementation

1.1 Argentina: Highlights of ICTs for e-Health in Argentina

1.1.1 Introduction

¹Accessibility to resources, goods and services in healthcare, regardless of geographical location and socioeconomic status, is one of the key factors to ensure that citizens of every nation effectively exercise their Health of Right. Telemedicine, as long as it involves the provision of health care services using information and communication technologies (ICT) for the prevention, diagnosis and treatment of disease, as well as for research and continuing medical education, has become one of the conceptual developments with the greatest potential for ensuring access to health services that meet appropriate quality and coverage standards.

The purpose of the following presentation is to synthetically describe Telemedicine strategies, programs and projects currently under development in Argentina.

1.1.2 Objectives and Strategies

The geographic and demographic characteristics of the country, the diversity of systems to health care access and the unequal distribution of professional resources and equipment, allow planning strategies in which the use of telemedicine, in the widest sense of Telehealth, assist in ensuring the effective exercise of the Right of Health throughout the hole national territory.

In this regard, it has been deemed necessary:

- To develop Telemedicine tools and to implement Telehealth programs and models with adequate standards of quality, social impact, cost – benefit relationship, and interoperability, which allow all citizens reach a better and more equalitarian health care.
- To promote consensus that may unify criteria that will ensure, in the medium term, a legislative and political regulatory framework of ICT and Telemedicine in Argentina.
- To take advantage of already existing resources and programs, engaging them to new local developments and those more significant at national and international level.

1.1.3 Activities Implemented

From a general perspective, although there are some legislative initiatives, to date the country does not have a policy framework for the implementation of ICT in Telemedicine. Likewise, Telemedicine projects have not always benefited from properly manage or support, suffering the vicissitudes of economic and political changes and progressing sporadically and irregularly.

As background, we can mention the National Program for the Society of Information about ICT inclusion in the public sector. This program supported the National Telemedicine Project (2000) which sought the extension of a telemedicine network, establishing clinical and technological reference centers, deploying new terminals systems and mobile solutions (Resolution 10,869 of the National Communication Secretary–SECOM). The socio-economic crisis of 2001–2002 prevented its realization.

Currently, Argentina has a General Plan for ICT (Resolution 1357/97) led by the General Secretary of Communications, several interagency plans related to equalitarian access policies (Argentina Connected,

¹ Contribution: Guillermo Bill, Telehealth Network of the América, Argentina. See document [2/205](#)

Decret 1552, 2010), and Integrated Health Information System (SISA) under the Ministry of Health. The latter is a project of information technology with gradual implementation stages and based on a federal concept, meant to record health facilities, health professionals, research, congenital diseases, immunizations, blood donors and evaluation of health technology.

In an overview of the possible applications of ICT in various sectors concerning national development lines (White Paper on ICT-Project Foresight 2020–2009) the Ministry of Science and Technology (MST) considers e-Health as a paradigmatic shift needed to cope with Argentine Health System deficiencies. To achieve this, a drastic restructuring of the health system is necessary, combining the concepts of Telemedicine and Primary Attention Strategy (APS). In 2010 the MST passed a document entitled "Strategic area for information and communications technologies" (Order 004/10d) where Telehealth is considered as a priority issue.

Regarding the development of telemedicine specific tools, it is appropriate to highlight the background related to electronic health records (EHR). Many Argentine provincial states and municipalities followed the line of free software, such as the Group of Buenos Aires BioLinux and the National University of Rosario.

In the province of Salta, Telecom Argentina implemented, in 2009, a web EHR system for management of primary care (ACUARIO SIGMA), developed by the Iberoamerican Foundation of Telemedicine. This system links 49 public health centers with more than 2,000 users, managing 250,000 HER and scheduling 4,000 patients visits by day. GCBA managed several initiatives coordinated by the Health Information Systems General Directory who created a Telehealth Platform. The province of Santa Fe has a video collaboration platform based on open source software for synchronous training and teleconsultations, also allowing surgeries and ultrasounds transmissions. Similarly, in 1995, the Angel Project created the first complete and free medical software, taking into account the laws for Professional Practice (17132), Digital Signature (25506) as well as the Code of Ethics of the Medical Association of Argentina, being compatible with HL7.

Concerning specific education, we should mention that most of the innovative processes, programs and developments in telemedicine and e-Health are concentrated in the academic units of public medical schools in Buenos Aires, La Plata, Rosario, Cordoba, Mendoza, Entre Rios and Tucuman. The valid curricula to train future doctors at these centers include telemedicine and ICT. Also, there is a residence of Medical Informatics at Italian Hospital of Buenos Aires, Biomedical Informatics at GCBA and a postgraduate degree in Biomedical Computing Introduction at the Italian Hospital of Buenos Aires.

In the health care setting, several major hospitals provide projects and programs where ICT and Telemedicine are protagonists. We must mention the program of referral and contra referral of the Garrahan Hospital, which allows remote communication with pediatricians located in provinces that have joined the National Network Tele-Pediatrics. The hospital established the Latin-American Medical Telepresence Pilot Program and offers a Telemedicine Program in Infectious Diseases.

Mendoza has a Telehealth Network formed by universities, the Ministry of Health and private institutions. The Zaldivar Institute (devoted to ocular surgery) in Mendoza has a telemedicine program for monitoring post-surgical patients, first visits, second opinions and training of residents. The Northeastern University has a telemedicine program designed to support rural doctors in Chaco.

Doctors living in small towns of Córdoba province could reach the portal developed by the Telemedicine Center of the National University of Córdoba (UNC) in order to have second medical opinions. The "Mario Gulich Institute", emerging as a collaborative initiative between UNC and the National Commission for Aerospace Activities (CONAE), is developing various tools for applications of aerospace information to health care, including risk stratification tools for vector-borne diseases and training programs of health applied geographical processing.

Finally, in a country with 51.891 million subscribers to cellular networks, the concept of m-Health should not be neglected. There are more than 5,000 health-related apps for different smart phone models. In addition, several organizations representing health insurance systems and private prepaid companies

operate with cellular messaging systems for different events, such as doctor's arrival, confirmation of appointments, etc.

In the regional context, since October 2011, the Ministries of Health of Latin America and the Caribbean approved the Regional Strategy and Plan of Action on e-Health, whose development the Panamerican Health Organization, World Health Organization (PAHO/WHO), has the mandate to coordinate. This strategy envisages that by 2017 a large percentage of countries have developed their own ALAC National e-Health strategy and represents a challenge and an opportunity for advancement and mobilization for action in Argentina as in all countries of the Region.

1.1.4 Technologies and Solutions Deployed

The key to establish a national telemedicine project is to take advantage of the already installed technology and new programs under development, to promote professional training and to reach agreements on regulatory requirements. In this sense, the Integrated Health Information System (SISA) appears as a possible starting point for major developments and projects in telemedicine.

A program to be considered of immediate usefulness is the national fiber optic network of the Ministry of Federal Planning, Public Investment and Services. Also depending from this Ministry we can find the Argentina Connected Program, as a comprehensive connectivity strategy as well as the three national communication satellites (ARSAT-1, 2 and 3).

National Universities have developed tools for remote support to patients. The Telemedicine Center of the UNER has prototypes and platforms of great social impact potential and low cost. The Institute of Bioelectronics in Tucumán has developed a Rural Telemedicine Application. The Faculty of Medicine of the National University of Rosario has launched a mobile telemedicine station (ETMo) containing sophisticated diagnostic tools built into a suitcase transportable by air, sea or land, able to provide the physician in disaster and/or geographical detachment situation, diagnostic and therapeutic aid from academic specialist located at the university in real time.

1.1.5 Outcomes Achieved. Challenges and Success Factors

Beyond the technical advances, ideas and projects conceived, the Argentina Telemedicine Community achievement has been sustaining internal stability in their working groups, showing the potential social impact of telemedicine and ICTs related to health topics and, last but not least, progressively installing at institutional and government levels the idea that telemedicine is not only important but essential in a Federal and Democratic Integrated Health System.

The unsolved challenges are related to absence of specific legislation, scarcity of means to finance the various projects, the need to train health professionals in the management of the Telemedicine tools, and the slow incorporation of knowledge about the concept of Telemedicine in potential system users and authorities.

A possible successful alternative should be the integration of efforts, the sheared use of technological equipment and human capital available, with the input from the various government levels, investors and private providers of technical resources, as well as academic and hospital medical staff.

Following this vision, emerged the Telehealth Network of the Americas, an organization developed within the OAS-CITEL, which has been formally joined by all medical schools of public administration, various national high complexity hospitals and Ministries of Health of some provinces.

1.1.6 Lessons Learned and Next Steps

The country current situation, with all its infrastructure developments and policies of inclusion and equity, together with the actions of the State and international organizations, to generate a optimistic picture. That is already assembled and tuned the expert protagonists in e-health, appointed before, working together. Is imminent an remarkable progress of e-Health in the country, involving the National State,

international agencies, academic and welfare institutions, and the experts who are developing projects and programs worldwide reference.

1.2 Bangladesh

1.2.1 Introduction

²Bangladesh is a densely populated country of around 150 million within an area of 150,000 sq. Kilometres with a per capita income of <1000 USD (700–750). The medical professionals including specialist doctors are mainly concentrated in capital city Dhaka and other large cities along with the concentrated tertiary care hospitals. While most people are still living in rural areas, the disparity in health care delivery is easily apprehended by the distribution pattern of the medical expertise and healthcare facilities. The discrepancy opens the options of either establishing equipped health facilities in rural areas or improving the infrastructure so that the service providers feel motivated to stay in village and impart in health service, or to initiate an alternative to provide quality health care to rural areas. In this very aspect Telemedicine can play a vital in a developing country like Bangladesh. There have been small initiatives from some private organizations like BIRDEM, Medinova Telemedicine, Grameen Telecommunication Network, Bangladesh Telemedicine Services, DNS Telemedicine etc. along with personal correspondence like Canadian expatriate initiative with some professors through Grameen Telecommunication Network. But these are very much sporadic and the results of these initiatives are yet to be tested.

1.2.2 Benefits and Future Opportunities

Computer literacy and skill is an integral part of activities in Telemedicine. However, medical professionals are not sufficiently skilled in computer literacy. Training of the medical professional, establishing infrastructure, initiating basic information system, protracted service system and sustainable feedback of the initiative would enable the vast majority of the medical professionals to get on board.

Cost effective service by staying away from travel and accommodation for investigation and consultancy would have been achieved. The family care environment would also be retained for the patient. The emergency services would have been prompt with specialized consultancy served from central to remote and isolated areas. The physicians working in rural areas get the mental strength of handling the patients in their vicinity and thereby the intellectual faculty development becomes a sustainable process.

The telemedicine service can be incorporated in health service networking system connecting the divisional districts with a central server based network. Through collaboration with developed countries telemedicine service could be widened to monitoring of cardiac, respiratory, diabetic, renal and other patients to combat emergency situation. Interactive Continuing Medical Education (CME) and training programs can be initiated to keep track of the latest advances and applications in medical technology and telemedicine. ITU can play a pivotal role to establish tele-consultation network. Robotic tele-pathology network is a dream with pathologists in Dhaka.

The main obstacles that are currently hindering the effort are security and confidentiality of data management, record keeping skill of the facilities, computer literacy, motivation and attitude of the service providers, scarcity of telemedicine supported equipment, patient awareness of the services, network connectivity and speed, cost of band width, and finally, government initiative, policy and support towards this growing demand of service provision.

² Contribution: Syed Muhammad Baqui Billah, MHFW, Bangladesh. See document [RGQ14.3.2-INF-0023](#)

1.2.3 Conclusion

Health service in Bangladesh is creeping and crawling with the developing economy albeit geographic barrier has become a live history. Medical knowledge should not be constrained by geographical borders. We want to think globally but act locally to bridge the digital divide.

1.3 Ghana: Ghana Health Service (GHS) e-Health Enterprise Architecture

1.3.1 Background to the GHS EA Programme

³The Government of Ghana through the Ministry of Communications commissioned the development of the national Enterprise Architecture (EA) to serve as the technology blueprint for all Ministries Departments and Agencies (MDAs). It is believed that an EA can deliver that improved focus by enabling more informed decision-making and enhanced collaboration between agencies by highlighting opportunities for common solutions, information sharing and concurrent cost reduction. As part of the process, the GHS EA was also developed to enable the Service implement the appropriate e-Health solutions to improve the delivery of services to citizens.

The GHS is a Public service agency established under Act 525 of 1996 as an autonomous agency responsible for the implementation of national policies under the control of the Minister for Health through its governing Council – the Ghana Health Service Council.

The GHS is an independent body with the freedom and flexibility to carry out its functions defined by the Act. The Service therefore needs to develop the appropriate strategies to support its mandate and the EA provides the perfect platform for the GHS to meet its responsibilities by defining the framework for technology selection and implementation strategy to improve health service delivery in the country.

The GHS EA is more than just technology architecture. It involves different architecture perspectives (Business Architecture, Applications Architecture, Data Architecture and Technical Architecture and security architecture), which are key to the implementation of an e-Health Programme.

The GHS EA describes the underlying infrastructure and provides the framework for aligning business and IT strategies of the GHS, enabling the integration of the GHS with organisations such as the National Health Insurance Authority (NHIA) and other international bodies.

The GHS has since adopted the EA reviewed and modified by GHS-EA review committee and has expressed its desire to start the implementation of the EA. It is generally accepted that EA implementation would enable the GHS meet some of its organisational challenges such as improving the delivery of service across the country and improving the efficiency of the Service.

The document serves as a comprehensive introductory paper covering the key aspects for a national rollout of the e-Health technologies. It also acts as a guide on how the different roles of national and local bodies as well as external consultants and Suppliers in the Programme will be achieved.

The Implementation Programme Strategy defines the necessary structures to minimise the risks of failures associated with technology projects in Ghana. It has been designed to avoid some of the mistakes made by other projects in the health sector, which have cost the government a considerable amount of money without delivering real value.

³ Contribution: Policy Planning Monitoring and Evaluation Division, Ghana Health Service. See document [RGQ14.3.2-C-0012](#)

1.3.2 Programme Scope

The key aim of the e-Health Programme is to give healthcare professionals access to patient information safely, securely and easily, whenever and wherever it is needed. It is an essential part of the drive to improve patient care by enabling clinicians and other GHS staff to increase their efficiency and effectiveness.

The Programme is expected to cover all aspects of patient care, the management of facilities, assets and employees as well as the improvement of business processes under the control of the GHS. The scope of the Implementation Programme will be determined by a number of factors or constraints such as availability of funds. The Programme must also ensure the interfaces with other stakeholders such as the NHIA are effectively maintained by developing the appropriate solutions.

1.3.3 Key Areas to be Considered

The key areas to be considered include:

- Electronic Health Records (EHR) – an important element of EA is the widespread adoption of interoperable EHR. Effective use of EHR has the potential to positively influence both the quality and cost of health care for the nation. The EHR can improve quality by presenting clinical information and comprehensive patient data to the clinician at the point of care. This allows more informed decisions in a shorter time frame. Additionally, the cost of care can be decreased by streamlining data collection, decreasing the likelihood and associated cost of medical errors and by reducing resources used for duplicative or unnecessary information capture and testing.
- Improving data sharing between the GHS and other national and international agencies. One of the key priorities of the Programme is the implementation of the appropriate data exchange mechanism in SDMX standards that will ensure timely and secure transfer of data between the GHS and the agencies, particularly the NHIA.
- A medical billing system that will enable the health facilities to produce medical bills for the payer organisations such as NHIA. The prompt payment of bills is of immense priority to the GHS.
- The need for the introduction of best in class applications to automate business processes such as Clinical Services, Public Health services, Scheduling and Capacity Management, Operational Research, Performance Management, Monitoring and Evaluation, etc.
- A robust network infrastructure that will enable the GHS to connect the health and administrative facilities across the country.

The overall aim of the GHS EA is to move Healthcare towards a series of easily available, interconnected, reliable and efficient services. The EA is a model on which such solutions can be built.

The GHS EA presents a detailed analysis of the current state of the GHS' business and ICT environments with the aim to improve services provided by the Service. It also provides a roadmap to move away from current applications and supporting technologies to an environment that better meets the current and future needs of the Service.

1.4 Central African Republic: Mise en œuvre du Projet Cybersanté en République Centrafricaine

⁴La République Centrafricaine est un pays enclavé, situé au centre du continent africain. Elle couvre une superficie de 622.984 Km² [18]. Elle partage une frontière commune avec la République du Tchad au Nord, la République Démocratique du Congo (RDC) et la République du Congo au Sud, la République du Cameroun à l'Ouest et la République du Soudan à l'est.

La population est estimée à 4.216.664 habitants.

Seulement 45% de la population a accès aux soins de santé de base.

La RCA est subdivisée en sept régions sanitaires et ces dernières ne sont pas en contact permanent; ainsi si nous arriverons un jour à mettre en place la cybersanté dans ce pays nous allons faire un grand pas dans l'amélioration de la prise en charge des patients.

Cybersanté est un terme utilisé aujourd'hui par tout le monde pour décrire l'application des technologies de l'information et des communications dans le secteur de la santé. Il englobe toute une gamme de buts qui vont du purement administratif à la prestation des soins de santé.

1.4.1 Objectifs de la Cybersanté en RCA

La cybersanté fait entrer le système de la santé dans l'ère du numérique et celui-ci atteint ainsi un haut niveau de qualité, d'efficacité et de sécurité, elle a pour objectif:

De rendre le dossier patient électronique accessible en tout lieu et en tout temps.

Les personnes en RCA obtiendront un accès sans restriction à leurs propres données médicales grâce à la cybersanté. Le personnel de la santé et les ayants droit peuvent rapidement avoir une vision globale de l'anamnèse d'une personne. Le diagnostic pourra être établi plus rapidement et plus précisément, ce qui pourra sauver des vies en cas d'urgence.

De mettre des services en ligne présentant des informations sanitaires de qualité afin de promouvoir la culture sanitaire personnelle

La simplification d'accès à des informations médicales sûres et qui ont préalablement été évaluées, aide la population à prendre des décisions relatives à sa santé, ce qui a généralement un impact positif sur la santé.

D'instaurer la télémédecine et le télémonitorage dans les sept régions sanitaire du pays: prise en charge et conseils médicaux à distance

La prise en charge du patient et les diagnostics pourront être effectués à distance grâce aux technologies de l'information et de la communication(TIC). Le télémonitorage fait partie de la télémédecine et comprend principalement la surveillance des patient(e)s sans l'aide d'aménagements médicaux.

1.4.2 Les Avantages de la Cybersanté en RCA

La cybersanté améliore la qualité de vie, du travail et du lieu, ce qui représente un facteur économique croissant. Une fois installée et les objectifs atteints, elle va nous présenter plusieurs avantages à savoir:

Avantages médicaux de la cybersanté pour les individus, les corps professionnels et les institutions de la santé.

⁴ Lemotomo St Alban, Ministère chargé des Postes, Télécommunications et des Nouvelles Technologies, République Centrafricaine. See document [SG02-C-0217](#)

Le dossier patient électronique, les services en ligne ainsi que les conseils et les consultations médicales à distance amènent de nombreux avantages:

- **pour les individus en RCA**

Avec la croissance de la mobilité, les services en ligne renforcent la culture sanitaire des individus, ce qui les aide à prendre des décisions concernant leur santé et a un impact positif sur leur santé personnelle ainsi que sur leur ressenti.

- **pour les corps soignant et médical**

L'accès rapide aux données du patient aide les médecins autorisés à établir rapidement un diagnostic précis. Il est ainsi possible d'éviter de réaliser plusieurs fois le même examen et des erreurs de prescription de médicaments. Les erreurs de lecture peuvent être évitées grâce à la prescription en ligne. Les pharmaciens ayant un accès contrôlé au dossier du patient peuvent reconnaître rapidement les médicaments auxquels le patient est allergique ou ceux occasionnant des effets secondaires. L'introduction des TIC dans le domaine sanitaire en RCA va aussi permettre aux différents sites de prise en charge des personnes vivant avec le VIH de réduire au maximum le nombre des doublant ce qui permettra au ministère de la santé d'avoir des données fiables quant au VIH en RCA.

- **pour les institutions de la santé**

Les services en ligne du système de la santé facilitent les procédures entre les médecins, les hôpitaux et d'autres fournisseurs de prestation, permettant ainsi de renforcer la coordination entre les différents acteurs et d'accélérer l'échange d'informations. Un système de santé comportant des processus efficaces a une incidence sur les coûts de santé.

Avantages administratifs de la cybersanté dans le domaine de l'assurance maladie.

L'utilisation des TIC dans le domaine de la santé simplifie les procédures administratives, comme par exemple l'émission de factures, et permet ainsi de faire des économies.

Avantages de la cybersanté sur l'économie.

La constitution et le développement systématique de services de santé en ligne va représenter un nouveau secteur de services. Il contribuera à l'amélioration de la santé et constitue également un facteur économique croissant. Dans l'ensemble, la cybersanté améliore la qualité de la vie, du travail et du lieu au sein du pays et ouvre de nouvelles possibilités d'exportation.

1.4.3 Conclusion

La cybersanté est un élément essentiel du renouveau en soins de santé: son application au système de soins de santé centrafricain, grâce aux améliorations de l'accessibilité, de la qualité et de l'efficacité du système, résultera en avantages pour les Centrafricains. Le gouvernement Centrafricain pourra investir dans ce domaine.

Un facteur clé du succès du travail du gouvernement est son solide engagement à collaborer.

1.5 Côte d'Ivoire: La Télémédecine en Côte d'Ivoire

1.5.1 Introduction

⁵A l'instar de nombreux pays, nous avons compris l'importance des NTIC dans le domaine de la médecine. Cependant nous nous trouvons dans une situation difficile, à tel point que de nombreux projets ont été

⁵ Logbo-Allomo Tania, ATCI, Côte d'Ivoire. See document [RGQ14.3.2-INF-0002](#)

abandonnés. Il s'agit pour nous de faire l'état des lieux de la télémédecine en Côte d'Ivoire, de situer nos besoins et surtout de recenser les projets les plus urgents.

Etat des Lieux

A. La formation

Nous avons des besoins pressants en matière de télémédecine. Dans un premier temps il s'agit d'avoir un personnel qualifié. A ce propos, nous pensons que la formation des ressources humaines (Médecins, infirmiers et informaticiens) pour démultiplier le système de télémédecine à Abidjan et en Côte d'Ivoire est d'une importance capitale. A cet effet, La SIBIM, Société Ivoirienne de Biosciences et Informatique Médical, a voulu mettre en œuvre le plan de formation qui consisterait en l'Organisation d'ateliers de formation à l'intention des professionnels de la santé et des professionnels des NTIC.

Les objectifs de ces ateliers seraient entre autres:

- Mettre à niveau en informatique de base des professionnels de la santé (Word, Excel, Powerpoint, Open Office, Acrobat professional);
- Fournir une vision globale sur les outils de l'informatique médicale;
- Apprendre les bonnes techniques de recherches d'informations médicales en ligne sur les moteurs de recherche;
- Apprendre à créer et à mettre en ligne les cours sur un système de télé-enseignement;
- Favoriser l'échange entre les professionnels de la santé et ceux des NTIC par le regroupement lors des ateliers;

Cette formation concernant directement les CHU, (Centres Hospitaliers Universitaires), devra intéresser d'abord les Directeurs Médicaux Scientifiques (DMS), coordonnateurs Télémédecine CHU et les Techniciens Informatiques.

Mais à ce jour, ce projet n'a pas encore été réalisé.

B. Le matériel

Nous manquons cruellement de matériel en Côte d'Ivoire. Le matériel informatique dont dispose les CHU et CHR sont désuets voire quasi inexistantes.

Ainsi, nous aurions besoin pour les CHU d'Abidjan et les CHR des régions de Côte d'Ivoire, d'équipements pour la retransmissions de la Télé – soins – enseignements. A savoir, la plate forme site web à partir de laquelle nous pourrions émettre nos cours et assurer les soins à distance, d'ordinateurs, de vidéo projecteurs, d'écrans de projection et de tous les accessoires qui accompagnent ces équipements pour faire de la Télémédecine. Enfin, Et à tout cela il faudra ajouter les bandes passantes: c'est le problème essentiel à résoudre pour faire éclore la Télémédecine en Côte d'Ivoire.

C. Le cadre juridique

Nous ne disposons en Côte d'Ivoire à l'instar des pays de la CEDEAO d'aucune réglementation ni de cadre juridique pour la télésanté en Côte d'Ivoire.

Nous avons cependant des acquis.

1.5.2 Les Acquis

En termes d'acquis nous avons:

- 1) La SIBIM, (Société Ivoirienne de Biosciences et Informatique Médical). Société scientifique et de vulgarisation de la Télémédecine, dans toutes ses composantes mais dont l'accent a été mis sur le Téléenseignement dispensé actuellement par le RAFT (Réseau Afrique Francophone de Télémédecine).

- 2) Un embryon de Télésanté (équipements et logiciels) au CHU de YOPOUGON (Abidjan) à travers un projet Indien dénommé RPSL. Il s'agit du Réseau Panafricain de Service en Ligne mis en place par l'Inde et 53 pays de l'Union Africaine qui consiste en une connexion par fibre optique et par satellite (RASCOS en l'occurrence) permettant de fournir des services de télé-éducation, télémédecine et de communication diplomatique. La télémédecine devrait à cet effet et entre autres, fournir les services suivants: la téléconsultation, la télésurveillance, la télé-chirurgie, la téléformation, l'éducation Médicale Continue (formation continue de 500 médecins et 1000 infirmiers en 5 ans), les logiciels de gestion des patients, des logiciels de stockage de données et de transmission des dossiers médicaux, la mise en place d'un centre de données devant gérer et tenir les archives. Ce projet rencontre quelques difficultés pour l'instant, compte tenu des circonstances du pays la situation sociopolitique du moment.
- 3) Projet PASRES en cours de réalisation. Le Programme d'Appui Stratégique à la Recherche Scientifique en Côte d'Ivoire (PASRES) est un programme financé par le Fonds Ivoir-Suisse de Développement Economique et Social (FISDES). Il a été soumis par le Ministère de l'Enseignement Supérieur et de la Recherche Scientifique (MESRS) et le Centre Suisse de Recherches Scientifiques en Côte d'Ivoire (CSRS). Il vient soutenir le MESRS dans son objectif prioritaire de création d'un Fonds National pour la Recherche Scientifique et Technologique (FNRST) en Côte d'Ivoire.

Le PASRES poursuit quatre principaux objectifs:

- financer des projets de recherche contribuant à la lutte contre la pauvreté;
- former des jeunes chercheurs pour assurer la relève scientifique au niveau des centres de recherche et des universités publiques;
- apporter des appuis aux structures de recherche en matière de réhabilitation des stations et laboratoires, de renforcement des capacités (équipements et connectivité) et d'accès à l'information scientifique;
- donner les appuis nécessaires à l'émergence d'un Fonds National de la Recherche Scientifique et Technologique en Côte d'Ivoire;

La dynamique de mise en œuvre du PASRES donnera des bases solides pour le développement durable de la recherche en Côte d'Ivoire. Le projet viendra revitaliser les capacités des structures de recherche lourdement affectées par la crise.

- 4) L'Emission de cours au niveau du RAFT depuis 2008.
- 5) Quelques équipements non fonctionnels.

1.5.3 Les Projets

Dans un futur proche, la Côte d'Ivoire a en projet les actions suivantes:

- 1) L'Acquisition d'un SERVEUR et Construction d'un site web pour faire de la Télémédecine au plan national;
- 2) L'Extension des salles où est installé le Projet Indien avec l'acquisition de climatiseurs. A cet effet l'ATCI et le CI-CERT prévoient de réaliser une salle entièrement équipée qui servirait pour le téléenseignement et la formation continue.
- 3) L'Extension de la Télémédecine vers les hôpitaux de banlieue situés aux alentours d'Abidjan tels que l'Hôpital Protestant de Dabou, celui de Bonoua, et ceux des deux plus grandes villes de l'intérieur, à savoir Yamoussoukro et Bouaké et enfin les CHR à moyens termes.
- 4) L'Acquisition d'équipements pour les villes suscitées.
- 5) Un séminaire sur la télémédecine mobile en Côte d'Ivoire afin de recenser les besoins et rechercher les financements pour des unités mobiles qui permettraient de développer la Télémédecine en

zone rurale. Ce, pour la prise en charge entre autres, des accouchements, accidents et pathologies telles que le Diabète, l'Hypertension Artérielle (HTA) et le SIDA etc. elle est impérative pour nous.

1.5.4 Conclusion

La télémédecine en Côte d'Ivoire est au stade embryonnaire. Les technologies de l'information et de la communication sont disponibles dans le pays (fibre optique sur toute l'étendue du territoire et d'une couverture réseau (mobile) très étendue) mais sont essentiellement concentrées dans les villes et gros villages; ainsi l'accès au matériel, l'absence de politiques sanitaires spécifiques, de formation et de moyens financiers constituent autant de défis devant être relevés dans la stratégie de déploiement de la télésanté en Côte d'Ivoire.

1.6 Guinea: Projet Panafricain de Service en Ligne (e-santé, e-Education) en République de Guinée

1.6.1 La Mise en Place du Projet

⁶Pour la mise en place du projet:

- 1) Le protocole d'accord entre chaque pays africain désireux de participer au projet et le gouvernement Indien.
- 2) Les documents sollicitant des offres auprès des pays membres pour abriter les super hôpitaux et Universitaire directrices. Lors de la session inaugurale du parlement panafricain tenue à Johannesburg le 16 Septembre 2004, le Président Indien a proposé la mise en place d'un projet.

De réseau de Télécommunication pour connecter les 53 Etats membres de l'Union Africaine dans le but de rendre efficace les communications et la connectivité entre les Etats.

Ce réseau panafricain comprendra les stations VSAT et des réseaux de câbles à fibre optique et permettra de fournir aux membres des e-services avec en priorités la Télémédecine et la TéléEducation.

Trois documents ont été élaborés à l'intention des pays membres par le comité spécial consultatif.

La Guinée a signé le protocole d'accords et fait ainsi partie des 19 premiers qui ont adhéré au projet.

1.6.2 Les Avantages du Projet pour les Pays Bénéficiaires

Les avantages du projet pour les pays bénéficiaires sont entre autre:

- Pour la Télé- Médecine: accès aux soins de santé dans des zones éloignés ou isolés,

Accélération des diagnostics et des traitements, réduction des couts et de l'isolement professionnel des docteurs en zones-rurales, meilleurs prise de décision entre malades et médecin traitant spécialiste.

- Pour la Télé-Education : une éducation de haute qualité à partir d'un studio ou les professeurs de niveau supérieur peuvent être réunis, professeurs en formation périodique, une approche pour l'éducation formelle et pour l'alphabétisation des adultes.

Conformément à la clause 5.3 du protocole, nous avons désigné un coordonnateur national et nous avons procédé à la mise en place d'un comité interministériel pour le suivi du projet.

Par la lettre en la date du 05 janvier 2007 adresse à Monsieur le Président de la république de Guinée, le président de la commission de l'Union Africaine a félicité notre pays pour cette démarche et a demandé, pour la mise en œuvre rapide du projet dont la coordination sera assurée par la commission de l'Union

⁶ Kébé Abdoulaye, ARPT, Guinée. See document [RGQ14.3.2-INF-0001](#)

Africaine, désignation au niveau national d'un coordonnateur, point focal, et la constitution d'une commission interministérielle pour le suivi effectif du projet.

Selon le rapport de la sixième réunion du comité de pilotage du Projet Panafricain de service en ligne, l'évolution du projet à ce jour, sur le plan africain se présente comme suit:

- 52 sur les 53 Etats signataires du protocole d'accord avec le partenaire Indien (TCIL) dont la république de Guinée.
- Sur 51 pays, 14 pays ont terminé l'implantation du projet et l'état d'implantation évolue dans les 17 autres.
- 46 Pays sur les 51 ont identifié les sites pour les trois e – services (Télémédecine, Télé Education et communication (VVIP), les 4 autres étant 1 à 2 sites prés identifiés.
- Les procédures d'acquisition des équipements et service pour les 51 pays sont achevées.

Les deux autres sites sont en phase d'étude.

L'évolution du projet en République de Guinée se présente comme suit:

La réception des équipements disponibles à la Direction Nationale des Postes et Télécommunications (DNPT);

- L'octroi de la licence e des VSAT et autre formalité réglementaires;
- L'identification et l'installation des trois sites devant abriter le Projet à savoir:
 - Le site de l'Université Gamal Abdel Nasser, siège du projet E-Education installé à 95%.
 - Le site de l'hôpital de Donka siège du projet E-Santé identifié et en phase d'installation (90%).
 - Du Département des Postes et Télécommunication (VVIP), siège du troisième site également identifié et en phase d'installation (80%).

Dans le souci de pérenniser ce projet, une réunion hebdomadaire est tenue par le comité de coordination national et une autre avec le cabinet de tutelle pour le suivi de l'évolution du projet.

A préciser que toutes ces démarches ont accompagnées des campagnes de sensibilisation à travers des correspondances adressées aux tutelles intéressées.

1.7 India: Telemedicine India Country Report

1.7.1 Introduction

⁷Most telemedicine activities are in the project mode, supported by the Indian Space Research Organization, Department of Information Technology, Ministry of External Affairs, Ministry of Health & Family Welfare and few others are being implemented through state government funding. None of the programmes are being adopted into the health system. A few corporate hospitals have developed their own telemedicine networks. Some of the nationwide projects being taken up by the Ministry of Health in the Government of India are Integrated Disease Surveillance Project (IDSP), National Cancer Network (ONCONET), National Rural Telemedicine Network, National Medical College Network and the Digital Medical Library Network. Telemedicine standardization and practice guidelines are being developed by the Department of Information Technology in the Government of India. A National Telemedicine Task

⁷ Contribution: S.K. Mishra, Department of Endocrine Surgery & School of Telemedicine & Biomedical Informatics, SGPGIMS, Lucknow, India. See document [RGQ14.3.2-INF-0004](#)

Force was set up by the Health Ministry in the year 2005. The terms of reference covered all aspects of e-Health. Various committees and subcommittees have presented their reports. A follow-up action plan is awaited. The External Affairs Ministry has taken up the Pan-African e-Network Project and the SAARC Telemedicine Network Projects²⁰.

The National Knowledge Commission, a high level advisory body to the Prime Minister of India formed with the objective of transforming India into a knowledge society, has also set up a Working Group for the development of an Indian Health Information Network. This working group has proposed to design, develop, and integrate an end-to-end electronic health care informatics network framework in India to improve public health, health research, and the delivery of health care. A National Resource Center for Telemedicine & Biomedical Informatics is being developed at Lucknow with the support of the IT department of the Government of India. This will piggyback on the infrastructure of the School of Telemedicine & Biomedical Informatics (STBMI)² set up by the Uttar Pradesh state government. Besides meeting the need of capacity building in telemedicine and e-Health for the country, this school will be accepting overseas candidates also. Currently, Diploma Courses are being carried out by the STBMI.

India is acquiring a sizeable market segment in health care BPO (business-process outsourcing) and KPO (knowledge-process outsourcing) industries. It is now preferred as a healthcare destination for neighboring and far-off countries. Most of these patients are being catered to by the corporate hospitals. At the same time, both short- and long-term travel by overseas citizens is increasing for business and tourism purposes which increases the potential for the use of telemedicine and e-Health tools to facilitate exchange of electronic health information between hospitals across the globe. The so called medical tourism is getting a boost.

Orissa Trust of Technical Education and Training (Ottet) takes the lead using modern ICT platform and network in Public Private Partnership (PPP) mode in association with Government of Orissa to provide promotive and preventive healthcare and disease management. Delivery of healthcare services at the door steps of villagers in 51,000 villages of the state is envisaged³². Gujarat state government is looking to expand telemedicine network in PPP mode. The state health department of Gujarat is all set to embark on to connect all villages through its telemedicine network. If things go according to plan, all panchayats (HQ of group of villages, first level of government administrative hierarchy) and schools in Gujarat villages would have visual-satellite connections within the next two to three years. National Institute of Mental Health and Neurosciences (NIMHANS), Bangalore and Mysore based K.R. Hospital has established connectivity for their telemedicine project in collaboration with Larsen & Toubro (L&T) Ltd., Bangalore which has gifted telemedicine solutions and equipment worth INR 600,000 to both the medical centers under Corporate Social Responsibility (CSR) initiative. Similarly, in April 2006 under the CSR program of Gas Authority of India Limited (GAIL), a telemedicine project was started linking SGPGIMS, Lucknow with District Hospital of Raibareli, located at a distance of 80 kms with fiber optic cable network. GAIL has upgraded the infrastructure by providing advanced videoconference equipment and designing and constructing a board room for eCME in the year 2010.

1.7.2 Electronic Medical Records and Hospital Automation

The majority of the hospitals in the country are rooted in manual processes, which are difficult to access. The insurance sector demands more efficient health information storage and retrieval. Automation alone can help hospitals to meet these challenges. Electronic Health Record (EHR) and Hospital Information Management (HIS) in India is still in the early growth stage. To start with it is a small market dominated by in-house design, development and implementation of customized solutions developed by software developers. In terms of technology adoption, India is far behind its Asia Pacific counterparts such as Australia, Japan, South Korea, Singapore, and Malaysia. Center for Development of Advanced Computing (C-DAC), an autonomous government scientific organization developed and deployed the first indigenously developed total Hospital Information System (HIS) software in collaboration with Sanjay Gandhi Post Graduate Institute of Medical Sciences (SGPGIMS)²², Lucknow in the year 1998. C-DAC's HIS solution is now deployed in various hospitals like Guru Teg Bahadur Hospital (Delhi), Mahatma Gandhi Institute of Medical Sciences (Sevagram, Maharashtra). C-DAC has also developed Telemedicine enabled Hospital Information System. Currently, electronic medical records and hospital automation have been

rapidly getting adopted in most of the corporate and few public sector hospitals. Health system development projects in state governments aided by the World Bank are promoting rural electronic health records. Tata Consultancy Services (TCS) is developing a suitable solution to maintain electronic medical records (EMR) for the Tamil Nadu State Government⁶. Ministry of Health & Family Welfare has launched an initiative to standardize Electronic Medical Records for the country. The Apollo Hospitals Group is initiating a major project with IBM, to build a national health data network called Health Highway³⁰ to provide a diverse set of software applications for the healthcare segment. Health Highway will be offered as a hosted solution managed and maintained by IBM and Apollo with hospitals using it on demand via a pay-per-use model. A major thrust for adapting a standardized EMR is likely to come following the National Knowledge Commission's Working Group recommendation. It has suggested developing a common national EHR with a minimal data set and making it available in an open domain to encourage widespread use in the country. This would facilitate standards-based development of a knowledge base.

1.7.3 Telemedicine Initiatives

Department of Information Technology (DIT), Ministry of Communication and IT (MCIT), Government of India

The Department of IT has taken a pivotal role in defining and shaping the future of telemedicine applications in India. The DIT has been involved at multiple levels – from initiation of pilot schemes to standardization of telemedicine in the country. It has funded development of telemedicine software systems – the prominent ones being Mercury[®] and Sanjeevani[®] software by C-DAC. DIT has also sponsored the telemedicine project connecting three premier medical institutions – viz. SGPGI-Lucknow, AIIMS-New Delhi and PGIMER-Chandigarh. DIT has established more than 100 nodes all over India in collaboration with the state governments. Telemedicine network in West Bengal for diagnosis and monitoring of tropical diseases, Kerala and Tamil Nadu Oncology Network for facilitating cancer care, North-Eastern and Himachal Pradesh hilly states for specialty healthcare access are some of the prominent projects launched by this department.

Indian Space Research Organization (ISRO)³:

Towards societal benefit of indigenously developed space technology, Indian Satellite System (INSAT), ISRO³ has implemented telemedicine pilot projects around the country under GRAMSAT (rural satellite) program which are very specific to the development of the society. In collaboration with state governments it has established a Telemedicine Network consisting of 382 Hospitals-306 Remote/Rural. District Hospitals/Health Centers connected to 51 super specialty hospitals located in major states. Sixteen mobile Telemedicine units are part of this network. Andaman & Nicobar Islands and Lakshadweep are linked to mainland specialty hospitals through satellite connectivity. In collaboration with state government it has supported establishment of Karnataka state telemedicine network where all the district hospitals in the state are connected with five specialty hospitals in Bangalore and Mysore. Similar operational network has been effectively functioning in the state of Rajasthan where all the 32 district hospitals are connected with six medical college hospitals and S.M.S. hospital in Jaipur. ISRO has also assisted Maharashtra, Madhya Pradesh and Orissa states in establishing satellite communication based telemedicine pilot projects.

Ministry of Health and Family Welfare (MoH&FW), Government of India⁴:

MoH&FW is currently implementing Integrated Disease Surveillance Programme network connecting all district hospitals with medical colleges of the state to facilitate tele-consultation, tele-education/training of health professionals and monitoring disease trends. It has funded few pilot projects at national level such as; tele-ophthalmology and rural telemedicine projects. OncoNET India project is under implementation which will network 27 Regional Cancer Centers (RCCs) with 108 Peripheral Cancer Centers (PCCs) hospitals to facilitate national cancer control programme. National Rural Telemedicine Network (NRTN) Project under National Rural Health Mission (NRHM) is under implementation phase.

Recently, the ministry has decided to implement National Medical College Network project under the central scheme - e-Health including telemedicine in which all the medical colleges of the country will be linked with high speed high bandwidth optic fiber backbone from "National Knowledge Network". The proposed network will empower learners and teachers to practice distance medical education using various ICT enabled educational technologies. The digital medical library consortium created by the National Medical Library will be able to expand its reach using this network.

State Governments:

To strengthen the healthcare facilities in their states, the governments of Orissa and Uttar Pradesh supported networking of their secondary level hospitals and then further linked them to SGPGIMS, Lucknow for specialty consultation⁷. C-DAC is now implementing the third phase of telemedicine network in Orissa by connecting remaining 22 districts hospitals. State-level central telemedicine resource centre is coming up on the premises of SCB Medical College and Hospital, Cuttack for promoting, monitoring, storing and maintaining entire state telemedicine activities and digital medical contents¹⁸. The Government of Chhattisgarh with the support of ISRO has established state wide network linking state Government Medical Colleges at Raipur and Bilaspur which in turn have been linked with premier hospitals across the country. Rajasthan State Government also, in collaboration with ISRO, has established Telemedicine network between 6 state medical colleges and 32 district hospitals and 6 Mobile Vans. Karnataka State Telemedicine Network Project run by an autonomous trust formed by the State Government has set up 30 nodes in collaboration with ISRO. Intel has initiated a joint telemedicine programme to take the benefits of healthcare to rural Karnataka in association with the state government²⁶. Andhra Pradesh state government is planning to launch mobile clinics that would daily visit two villages to check blood pressure, diabetes and other health parameters of people and also carry out telemedicine through "104 services". Gujarat is also starting "104 services" over phone. People can call up and talk to paramedics in call centers who can suggest the primary action to be taken in case of any health emergency. Also, they would be able to suggest generic and over the counter drugs." Punjab government also launched a Telemedicine Project, with state-of-art facilities at Government Medical College and Hospital to link the five polyclinics set up in the state. In Himachal Pradesh 19 health centers at district, block and tehsil headquarters connected with Indira Gandhi Medical College, Shimla and Postgraduate Institute of Medical Education & Research Chandigarh through ISDN link²⁴. The Gujarat government will soon launch a Telemedicine Project with the Indian Space Research Organisation (ISRO) as its technology advisor to enhance the quality of healthcare services in the remote areas of the state. Under this project, government plans to cover 50 Community Health Centers, mainly in interior tribal and coastal areas of the state within a year. Later, this facility will be extended to other remote areas³⁰. Maharashtra state has deployed Telemedicine network linking 28 District hospitals with Nanavati super specialty hospital under National Rural Health Mission.

Telemedicine Initiatives undertaken by large hospitals: Academic/Public/Corporate

Various tertiary level super specialty hospitals in public and corporate sector have taken initiatives in telemedicine program with the help of government agencies or on their own. Many of them have now completed a decade of telemedicine journey. Sanjay Gandhi Postgraduate Institute of Medical Sciences (SGPGIMS), Lucknow, a premier academic medical institution in the public sector, started telemedicine activities in the year 1999 in project mode with the support of various government agencies. SGPGI Telemedicine network has linked 27 national and international nodes and has been carrying out tele-education and tele-healthcare activities. Research and development is one of the focus areas at this center. SGPGI has set up a School of Telemedicine and Biomedical Informatics to train man power in the field of telemedicine and e health. Department of Information Technology, Government of India has now recognized it as a National Resource Center in Telemedicine and Biomedical Informatics. All India Institute of Medical Sciences (AIIMS), New Delhi connected with Jammu & Kashmir, Haryana, Orissa, North East states network and PGIMER, Chandigarh connected with Punjab and Himachal state network and Sri Ramachandra Medical College and Research Institute, Chennai connected with Andaman & Nicobar Island Hospital, Amritha Institute of Medical Sciences, Kochi connected with Lakshwadeep island, Tata Memorial Hospital, Mumbai, Christian Medical College, Vellore are involved actively in Telemedicine.



In corporate sector, the major players are Amrita Institute Medical of Sciences (AIMS), Kochi (69 nodes), Apollo Hospital Group (150 nodes), Asia Heart Foundation, Bangalore, Mumbai (02 nodes), Fortis Hospital (20 nodes), Narayana Hrudayalaya (26 nodes), Dr. Balabhai Nanavati Hospital, Mumbai (32 Nodes) and Escorts Heart Institute and Research Center (08 nodes). Recently Sir Ganga Ram Hospital, New Delhi has launched its telemedicine centers in Haryana and Rajasthan states. With the support of ISRO, Shankar Nethralaya at Chennai, Meenakshi Eye Mission at Madurai and four other corporate eye hospitals have launched Mobile Tele-ophthalmology service for early diagnosis and treatment of ophthalmic diseases under National Blindness Control Program. Sir Ganga Ram Hospital, New Delhi and AIMS, Kochi have launched mobile Tele-hospital for rural access of specialty healthcare services. Hyderabad-based Global Hospitals announced the opening of their information and telemedicine centre in Ahmadabad. The telemedicine centre in the city is the fourth after Kolkata, Puducherry and Bhubaneswar. The telemedicine centre will help them to reach out to the specialists in Hyderabad and Chennai²⁹.

1.7.4 Example of a successful development is the m-Health Tool Kit for Low Resource Countries

Introduction

With over 506 million mobile phone subscribers in a low resource country like India, growing at approximately 10 million per month, mobile networks have now become the country's largest distribution platform, promising to deliver information and public services to the masses through innovative applications. On current trends, m-Health systems will be more widely offered by mobile telecommunication service providers, and simple, yet important functions may even be offered as built-in features of mobile phones¹. Mobile platforms world-wide are being used to provide financial and banking services, agriculture information, health services, telemedicine and e-education in rural and remote areas. The initiatives to provide various services using mobile applications have already started in India. m-Health application potential can be leveraged to boost social and economic activities, governance, and enhance government-citizen interaction. For this transformation to be inclusive and beneficial for the under-privileged and rural population, an innovative and low cost model has to be addressed in the context of developing countries.

Material and Method

m-Health4U[®], a portable low cost mobile telemedicine kit, was conceptualized, designed and a prototype developed at the m-Health research laboratory STBMI in 2008. Two versions were worked out, i.e. m-Health4U-B (Backpack) and m-Health4U-S (Suitcase) having a weight of 2–4 kilogram depicted in Fig. 1.

After bench testing, a proof of concept study was undertaken in the field to test transmission of vital signs and ECG and software based videoconference using wireless broadband media during a local festival in the month of June 2009 and 2010 (refer to Fig 2. for technical architecture). An enterprise based six node wireless telemedicine network was set up connecting specialty hospitals at Bhubaneswar and Cuttack, and Orissa in the eastern coast of India using wireless broadband network to exchange ECG and carry out videoconference for tele-consultation. The outcome was successful transmission of vital sign data and videoconference. Subsequently, pilot field deployment was carried out in the State of Gujarat, western India in the month of November 2010. In-service paramedical, laboratory technician and nursing staff were identified to carry out the pilot project. Basic orientation, demonstration and hands-on training were imparted to give them first hand exposure on the kit and then the kit was installed in four Primary Health Centers (PHC) and one Community Health Center (CHC). All five nodes were connected over mobile wireless internet with the expert hospital located in the city. The electronic medical record was created using the Curesoft® telemedicine software and the input from integrated medical devices like ECG, NIBP, and Spo2 etc. were captured through USB 2.0 port into this software, which was then exchanged between the nodes, followed by a videoconference session for tele-consultation after the successful transmission of the data to the specialist.

Result

The outcome of the “proof of concept” was quite satisfactory. The doctors involved in the project were quite excited and found it an innovative solution for strengthening the healthcare services at their hospitals. Subsequently pilot deployment was started in a different environment. The patient data was transferred successfully between the expert doctors and remote end and videoconference could be possible even in low bandwidth. The doctors participating in the study suggested some minor changes in the software architecture, like incorporating more graphics to represent body parts. Overall performance of the kit was acceptable to them.

Discussion

The advancement of m-Health technology should be exploited in rural healthcare delivery setting in low resource countries where the mobile telecommunication network has already reached. The tool kit has been developed keeping in mind the basic health care needs in remote villages in an Indian setting, a situation akin to countries in the developing world. Besides the local available technology and skill, cost factor has been taken into account. While field deployment has been successful in testing, the local available mobile network, human factors such as acceptability of the device and operational simplicity were also taken into consideration.

Acknowledgement

The authors would like to acknowledge the financial grant support received from Department of Information Technology, Ministry of Communications & Information Technology, Government of India under the Project “National Resource Center for Telemedicine & Biomedical Informatics”.

References

- [1] <http://ehealth-connection.org/content/executive-summary> accessed on 25.01.2011
- [2] Singh Indra Pratap, Bhagat K N, Mishra S K “Technical Evaluation of Low Cost Telemedicine Solution in Indian Situation: A Case Study in Ratha Yatra Festival at Puri,” Abstract in the Proceedings 5th National Conference of Telemedicine Society of India, Pune, 6-8 November 2009

1.7.5 e-Learning in the-Health Sector

Online Open Access Bibliography:

Two government agencies, the National Informatics Center (NIC) and the Indian Council of Medical Research (ICMR) have established the Indian Medical Literature Analysis and Retrieval System (MEDLARS)

Center to cater to the information needs of the medical community of India. This ICMR-NIC Center for Biomedical Information has developed various web-based modules such as a union catalog of the journal holdings of medical libraries of India (<http://uncat.nic.in>), a bibliographic database of Indian biomedical journals (<http://indmed.nic.in>) and full texts of Indian biomedical journals (<http://medind.nic.in>).

Collaborative Knowledge Sharing through Telemedicine Network:

In the interest of professional knowledge sharing, premier academic medical institutions including AIIMS, PGIMER, SGPGIMS, Christian Medical College, at Vellore, and AIMS are actively involved in sharing their academic activities over the telemedicine network.

1.7.6 Education & Training in e Health towards Capacity building:

The Apollo Telemedicine Network Foundation

The Apollo Telemedicine Network Foundation, in collaboration with Anna University in Chennai, was the first to start a 15-day certification course in Telehealth Technology, which is a blend of technical, medical and managerial skills. The first course commenced in October 2003. As part of its efforts to popularize telemedicine, an interactive section on telemedicine has been made available in the division of emerging technologies at the renowned National Science Centre in New Delhi. Thousands of public individuals now have an opportunity to see telemedicine and learn about it.

SGPGIMS

SGPGIMS, in collaboration with the Uttar Pradesh State government and Department of Information Technology (DIT), Government of India, has taken the initiative to set up a School of Telemedicine and Biomedical Informatics in its campus. Curriculum based diploma courses was started in 2009. First batch of the diploma course has finished and second batch is enrolled in this session year. It will house different laboratories in the field of e-Health such as telemedicine, hospital information systems, biomedical informatics, medical multimedia and image management, medical knowledge management, artificial intelligence, virtual reality, and robotics. The objectives of the school are to create various resource facilities, run structured training programs, conduct research and development, and provide consultancy to government and private health care organizations in collaboration with technological and medical universities in the country and abroad. Five trainees from the Maldives (sponsored by the WHO), 30 Indian trainees sponsored by the government of Madhya Pradesh, and 13 Indian trainees sponsored by the government of Uttar Pradesh learned telemedicine technology and its application in October 2007 and February 2008. Two trainees from the DPR Korea (sponsored by the WHO), 38 Indian trainees sponsored by different organization in 2009 and 69 in 2010. The school is being identified as a "National Telemedicine Resource Center" by DIT.

Tele-training Center at National Institute of Health & Family Welfare, New Delhi

The Ministry of Health & Family Welfare in the Government of India is setting up a teletraining center at the National Institute of Health & Family Welfare in New Delhi to create a facility that will offer tele-training of public health professionals across the country through various e-learning modules. This will enable professionals to switch to more efficient electronic modes from the currently practiced on-site training modules. This initiative would boost capacity building in public health as has been envisaged under the National Rural Health Mission⁴.

The National Board of Examinations (an autonomous body under the aegis of Ministry of Health, Govt. of India) offers a satellite-based postgraduate e-lecture program in all medical specialties. It is now mandatory for every institution recognized by the board to make available the necessary infrastructure for receiving these programs.³³

e-Continuing Medical Education (e-CME)

MoH&FW is planning to network all the government medical colleges with high bandwidth fiber to facilitate an e-CME program.

e-Governance in the Health Sector under the State-wide e-Governance Network

DIT has launched the National e-Governance Action Plan (NeGP) to support the growth of e-governance within the country. The National Informatics Center (NIC) is the DIT arm that provides a range of services to all the government departments at the center, the states and the districts. A separate "e-Governance Standards Division" has been created by NIC to steer the process of evolving the standards.

Common Service Center (100,000 nodes), DIT Project

DIT has formulated a proposal to establish 100,000 common service centers (CSCs) in rural areas, which will serve not only as the front end for most government services, but also as a means to connect the citizens of rural India to the web. CSCs would extend the reach of electronic services, both government and private, to the village level. Various government departments have been advised to design and evolve their mission-mode projects, laying adequate emphasis on services and service levels with respect to their interface with citizens and businesses. Telemedicine has been identified as one of the service modules. It is envisaged that initially, 20,000 CSCs would have tele-health outlet service managed by a village-level entrepreneur.

Village Resource Centre (VRC)

The VRC concept has been evolved by ISRO to provide a variety of services such as tele-education, telemedicine, online-decision support, interactive farmers' advisory services, tele-fishery, e-governance services, weather services and water management. By providing tele-education services, the VRCs act as learning centers focused on the virtual community. At the same time, VRCs will provide connectivity to specialty hospitals, thus bringing the services of expert doctors closer to villages. Nearly 500 such VRCs have been established in the country.

1.7.7 Policy Initiatives

Ministry of Communication & IT

a. Standardization of Telemedicine Platform and Services

To standardize services of different telemedicine centers, a document called "**Recommended Guidelines & Standards for Practice of Telemedicine in India**" has been prepared by DIT. It is aimed at enhancing interoperability among the various telemedicine systems being set up in the country. These standards will assist the DIT and state governments and health care providers in the planning and implementation of operational telemedicine networks. To establish a telemedicine center, standards should be set for telemedicine systems, software, connectivity, data exchange, security and privacy. Guidelines should also be established regarding telemedicine interaction.

b. Defining the IT Infrastructure of Health

DIT also took initiative, in a project mode, for defining "**The framework for Information Technology Infrastructure for Health (ITIH)**" to efficiently address the information needs of different stakeholders in the health care sector.

Initiatives of Ministry of Health & Family Welfare (MoH & FW)

National Task Force on Telemedicine:

1. To work on inter-operability, standards for data transmission, software, hardware, training etc.
2. To define a national telemedicine grid and consider its standards and operational aspects.

3. To identify all players and projects currently involved in telemedicine in India and evaluate their performance, capacity and replicability.
4. To prepare pilot projects for connection of super specialty hospitals/ medical colleges with district hospitals and/or Community Health Centers /Primary Health Centers especially keeping in mind to provide access to remote areas.
5. To prepare national cancer telemedicine network.
6. To examine possibilities of utilization of standalone centers of department of communication in rural areas.
7. To define standards and structures of electronic medical records and patient data base which could be accessed on a national telemedicine grid?
8. To enable telemedicine centers in teaching institutions to impart training to all government medical/dental/nursing colleges in three years time.
9. To prepare curriculum and projects for CMEs through telemedicine.
10. To draft a national policy on “telemedicine and telemedical education” and to prepare a central scheme for the 11th Five Year Plan.

Medical Informatics Education for Graduate Medical Students

The Medical Council of India is considering the introduction of medical informatics in the course curriculum of graduate medical students.

1.7.8 National e-Health Projects under Planning and Implementation

Ministry of Health & Family Welfare Projects

a. National OncoNET Project:

Under the National Cancer Control Program, 27 Regional Cancer Centers will be linked with 100 peripheral centers for primary prevention, early detection, treatment and rehabilitation of cancer patients.

b. National Medical College Network:

The National Task Force on Telemedicine, set up by the Union Ministry of Health and Family Welfare, plans to establish a national grid on telemedicine for networking medical colleges. A few tertiary-care academic medical institutes from different regions of the country will be identified as medical knowledge resource centers (in a regional hub), each of them connected to medical colleges (nodes) in that region. One of these regional hubs will be identified as the central hub, which will have overall responsibility for coordinating the national network in addition to providing infrastructure for a central content development center.

c. National Digital Medical Library Consortium:

The National Medical Library’s Electronic Resources in Medicine (ERMED) Consortium is an initiative taken by the Director General of Health Services (DGHS) to develop nationwide electronic information resources in the field of medicine. A total 39 centrally-funded government institutions (including 10 under DGHS, 28 laboratories under the Indian Council of Medical Research, and the AIIMS libraries) have been selected at the initial stage as core members. The MoH&FW aims to provide funds required for the purchase of electronic journals under this consortium project.

Ministry of External Affairs Project:

a. SAARC telemedicine network²⁰

The South Asian Association of Regional Cooperation (SAARC), created as an expression of the region's collective decision to evolve a regional cooperative framework, received a major impetus during the 14th SAARC Summit held in New Delhi in April 2007. The pilot project connects one or two hospitals in each of the SAARC countries with three to four super-specialty hospitals in India. The super specialty hospitals in India include the SGPGIMS, Lucknow and PGIMER, Chandigarh which are connected with JDWNR Hospital, Thimphu, Bhutan; Indira Gandhi Child Hospital, Kabul, Afghanistan; and Patan Hospital, Kathmandu, Nepal. This is being developed as an exemplary model for implementing projects at the regional level. It has immense potential to expand the scope of regional cooperation to other ICT enabled areas such as education, business process outsourcing and mass communication.

b. Pan-African e network project:

The Ministry of External Affairs for the Government of India is implementing this project through Telecommunications Consultants India Ltd. (TCIL) to establish a VSAT-based telemedicine and tele-education infrastructure for African countries in 53 nations of the African Union. This will be accomplished via a satellite and fiber-optic network that would provide effective tele-education, telemedicine, Internet, videoconferencing and VoIP services and also support e-governance, e-commerce, infotainment, resource mapping and meteorological services. Ten super-specialty hospitals in India have been identified to provide tele-health services to 53 remote African hospitals. In August 2010, the second phase of the Pan-African e-Network project had been launched³¹.

e-Health Industry

Technologically, India is now self-sufficient in meeting the needs of hardware, software, connectivity and services. The prominent industries providing hardware and software supports are C-DAC; The Apollo Telemedicine Network Foundation in Hyderabad; The Online Telemedicine Research Institute in Ahmedabad; Televital India in Bangalore; Vepro India in Chennai; Prognosys Medical Systems Pvt. Ltd. in Bangalore; Medisoft Telemedicine Pvt. Ltd in Ahmedabad; Idiagnosis Technologies in Ahmedabad; and Karishma Software Ltd. in New Delhi. Many sturdy, standard HIMS solutions have been developed by the major IT companies such as C-DAC, Wipro GE Healthcare, Tata Consultancy Services (TCS), Amrita HIS Solution, Sobha Renaissance, and Siemens Information Systems Ltd (SISL).

1.7.9 Research and Development

DIT Initiative:

DIT, along with its societies such as CDAC and Media Lab Asia and in collaboration with many premier medical and technical institutions such as SGPGIMS, AIIMS, PGIMER and IITs, is involved in research, design, development and deployment of advanced telemedicine products and solutions. They also specialize in embedded and VLSI technology and biomedical, electronics, telemedicine and entrepreneurship development. C-DAC's Sushrut, a hospital information system (HIS) has been designed, developed and deployed at SGPGIMS¹. It has also developed the institution-based application oriented telemedicine software systems Mercury[®] and Sanjeevani[®] and validated them at three premier medical institutions: SGPGIMS in Lucknow; AIIMS in New Delhi and PGIMER in Chandigarh. This it has accomplished using ISDN and satellite connectivity. It is also developed web version of Sanjeevani (e-Sanjeevani)²².

SGPGIMS Initiative:

In collaboration with its technical partner, SGPGIMS developed and validated several application modules in telemedicine in addition to developing the prototypes Tele-ambulance for emergency health care, Mobile Tele-hospital for rural health care, and the portable suitcase telemedicine module for disaster situations.

Research publications:

India has contributed several research publications in peer reviewed scientific journals and book chapters in related field. A compendium of these publications can be found at: <http://www.telemedindia.org>.

References

- [1] <http://www.sgpgi.ac.in> Last accessed: 5 Feb 2011
- [2] <http://www.mit.gov>. in Last accessed: 5 Feb 2011
- [3] <http://www.isro.org> Last accessed: 5 Feb 2011
- [4] <http://www.mohfw.nic.in/> Last accessed: 5 Feb 2011
- [5] <http://www.ehealthonline.org> Last accessed: 5 Feb 2011
- [6] http://www.csi-sigegov.org/egovernance_pdf/15_121-127.pdf Last accessed: 5 Feb 2011
- [7] <http://www.sgpgi-telemedicine.org> Last accessed: 5 Feb 2011
- [8] <http://www.aiims.edu> Last accessed: 5 Feb 2011
- [9] <http://www.pgimer.nic.in> Last accessed: 5 Feb 2011
- [10] <http://www.tmc.gov.in> Last accessed: 5 Feb 2011
- [11] <http://www.telemedicineindia.com/> Last accessed: 5 Feb 2011
- [12] <http://www.fortishealthcare.com> Last accessed: 5 Feb 2011
- [13] <http://www.rtiics.org/telemedicine.htm> Last accessed: 5 Feb 2011
- [14] <http://www.fortishealthcare.com> Last accessed: 5 Feb 2011
- [15] <http://www.narayanahospitals.com> Last accessed: 5 Feb 2011
- [16] <http://www.sgrh.com> Last accessed: 5 Feb 2011
- [17] <http://www.sankaranethralaya.org> Last accessed: 5 Feb 2011
- [18] <http://www.cdac.in/html/press/2q10/spot707.aspx> Last accessed: 5 Feb 2011
- [19] <http://www.indmed.nic.in> Last accessed: 5 Feb 2011
- [20] <http://www.mea.gov.in/> Last accessed: 5 Feb 2011
- [21] <http://tcil-india.com/new/html/PAN%20Africa.html> Last accessed: 5 Feb 2011
- [22] <http://www.cdac.in> Last accessed: 5 Feb 2011
- [23] <http://www.telemedindia.org> Last accessed: 5 Feb 2011
- [24] <http://himachal.us/2009/02/28/telemedicine-project-proving-helpful-in-rural-himachal/11457/news/disha> Last accessed: 5 Feb 2011
- [25] <http://isc2010.in:8080/isc/isro.jsp> Last accessed: 5 Feb 2011
- [26] <http://daily.bhaskar.com/article/intel-launches-telemedicine-programme-in-karnataka-1640973.html> Last accessed: 5 Feb 2011
- [27] <http://www.panafricanenetwork.com/> Last accessed: 5 Feb 2011
- [28] <http://www.frost.com/prod/servlet/market-insight-top.pag?docid=57274416> Last accessed: 5 Feb 2011
- [29] <http://medinfo.cdac.in/resources/events/mig-symp-08/pdf/presentation/%20Ramakrishnan.pdf> Last accessed: 5 Feb 2011

- [30] http://www.siliconindia.com/shownews/HealthHiway_raises_4_Million_from_Greylock_Partners-nid-60976.html
- [31] <http://www.nrct.in> Last accessed: 5 Feb 2011
- [32] <http://www.ottet.in> Last accessed: 5 Feb 2011
- [33] <http://www.natboard.edu.in/>

1.8 Indonesia

1.8.1 Case 1: Development of A Low-Cost Automatic Field-of-View Scanning Microscope for Early Tuberculosis Detection Systems

⁸We developed a TB automatic detection system using commodity components. The system consists of an electro-mechanical digital microscope to record the FoV images of sputum samples, image processing software to detect and to count the number of the bacteria in the FoV, and a decision system to determine whether the patient is diagnosed as a positive TB or not.

Figure 1: The modified optical microscope that is capable of performing automatic FoV scanning.



The electromechanical digital microscope is actually a modified one from an ordinary low-cost optical microscope. We add a two-degree-of-freedom scanner made of two stepper-motors and a digital camera fixed in front of the microscope's ocular. Figure 1 shows the modified-microscope, placement of the stepper motors, and the driver card with a simple microcontroller.

⁸ Contribution: Andriyan Bayu Suksmono and Tati LR Mengko, School of Electrical Engineering and Informatics, Institut Teknologi Bandung, Indonesia. See document [RGQ14.3.2-INF-0007](#)

Figure 2: Two FoVs images of a sputum sample showing TB bacteria and its background

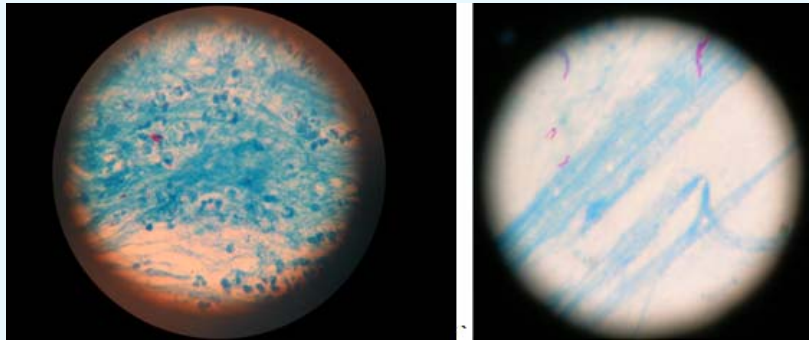

The image processing software and the decision system is now under-development. **Figure 2** shows two different FoV of the sputum microscopic images. The staining of the samples shows contrast of the TB bacteria with its background. The image processing software should be capable of separating the bacteria from the background. Then, the segmentation and counting process can be conducted.

Conclusions and further directions

We have described a low-cost automatic FoV scanning Microscope for early TB detection systems. Some parts of the system, i.e., the FoV automatic digital microscope, have been constructed. Our next steps are to complete the prototype with processing software, performing laboratory- and field- tests, and benchmarking with manual sputum analysis.

References

- [1] The Global Plan to Stop TB, 2011-2015: Transforming the Fight towards Elimination of Tuberculosis, World Health Organization, 2010
- [2] R. Lumb and I. Bastian, "Laboratory Diagnosis of Tuberculosis by Sputum Microscopy," The Handbook, Institute of Medical and Veterinary Science, Frome Road, Adelaide South Australia, 2005

1.8.2 Case 2: Picture Archiving and Communication System (PACS) and Teleradiology Development and Implementation

⁹Medical image becomes one of the most valuable assets in medical history and in supporting diagnosis process. Archiving and transferring medical image over telecommunication network is challenging, because of its size. It needs huge storage capacity to archive medical image in a health institution such as hospital. Our research since 2001 came out with effective compression method to compress the medical image in 16:1 ratio, yet maintaining the quality of image reconstruction over certain region of interest.

⁹ Contribution: Utoro Sastrokusumo, Andriyan Bayu Suksmono, Antonius Darma Setiawan Bandung Institute of Technology, Indonesia. See document [RGQ14.3.2-C-0007](#)

Figure 3: (Left) Application to manage medical image (right) Desktop Viewer



Figure 4: (Left) PACS viewer on Tablet PC (Right) PACS Viewer using large LCD touch screen



Our developed compression method was iterated for several years to meet the requirement from radiology expert. We named our compression method as Scalable Fuzzy Vector Quantization (SFVQ). In the year of 2011, biomedical engineering of Institute Technology of Bandung cooperated with private company which works on health care area to develop commercial PACS. At the end of that year the beta version of commercial PACS product was launched. The product was implemented at to hospital, Agam General Hospital in West Sumatera and Cililin General Hospital in West Java. The product was design in a very simple user, yet powerful enough. However, there are many rooms for improvement.

The PACS product consists of three major components. The first one is the application to manage all medical images inside PACS. The second one is the application server to manage the interaction between client and storage server or persistence server. The last one is image viewer. We developed three kind of viewer, which are desktop, large LCD touch screen, and tablet PC.

We also develop on the PACS enhancement based on requirement and actual need. There is a need to have teleradiology session between small hospital which lack of radiolog and large computer where there are expert on medical image. Based on this need we expand the capability of our previous product into teleradiology supported PACS.

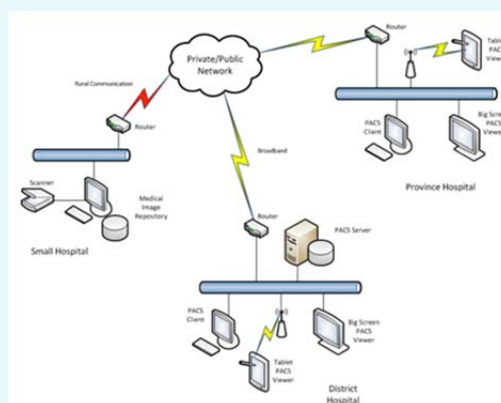
Figure 5: Teleradiology capability added into PACS

1.9 Kyrgyz Republic - E-Health Introduction in the Kyrgyz Republic - Experience and Further Steps

1.9.1 Introduction

¹⁰Since its independence in 1991, Kyrgyzstan has seen periods of democratic progress and of authoritarian backlash. With the fleeing of two presidents (in 2005 and 2010) after popular uprisings against authoritarianism, corruption and human rights violations; coupled with regional disparities and the repercussions of the inter-ethnic violence of June 2010, the country is going through a difficult process of transformation. In June 2010 several serious inter-ethnic confrontations took place in the south of the country. About 420 people died and 2,000 were injured, while over 2,000 houses and 300 businesses were destroyed. As result of June 2010 referendum a new constitution has been adopted. The new Constitution defines the Kyrgyz Republic as a parliamentary republic (during the previous 18 years, the country was a presidential republic) thus making it the only country with a parliamentary system in Central Asia. Parliamentary elections held in October 2010 were contested by 29 parties, with five winning places in Parliament and three forming a new coalition Government. Presidential elections held in October 2011 resulted in peaceful transfer of power. However, peace and social cohesion cannot be taken for granted, as the root causes of conflict, including inter-ethnic mistrust and regional tensions, eroded credibility of state institutions, social exclusion and uneven access to economic opportunities remain to be addressed. Kyrgyzstan in the past has seen concentration of powers around the presidency, with state institutions not perceived to be efficient, transparent or accountable. There is still work to be done to support the Government to strengthen the rule of law, address justice issues, reduce the prevalence of human rights violations, improve redress mechanisms and increase the independence and capacity of the judiciary, media (both public service and independent), the civil service and local government. Civil society's impact on decision-making still remains limited although its role has recently increased.

Kyrgyzstan has a GDP per capita of US\$2200 (2010) and is classified as one of two low-income countries in the Europe and CIS region. The economy grew 3.9% per annum in 2000–2005 and 3.7% in 2005–2010. In 2011 the economy grew 5.7%. Poverty fell from over 62% in 2000 to 32% in 2009, but after the 2010 events it rose back to 33.7% that year, with an increasing proportion of the poor being female. Foreign debt is \$2.803 billion as 2011, about 47% of GDP, while the budget deficit for 2012 is planned to

¹⁰ Contribution: Chynara Suiumbaeva, ICTD component coordinator, Democratic Governance Programme, UNDP Kyrgyzstan. See document [SG02-C-0202](#)

be about 5.7% of GDP. There is a large informal sector, particularly in services and agriculture. Meanwhile, 26% of households have at least one member working abroad. Remittances had risen to US\$1.7 billion by 2011, slightly over 30% of GDP.

With a human development index ranking of 126 out of 187, the Kyrgyz Republic is in the lower half of the medium human development countries. It raises seventeen places in the inequality-adjusted human development index. The country is 66 of 146 countries in UNDP's gender inequality index. The country's 2010 MDG report indicates that the country is unlikely to meet the MDGs for child and maternal mortality, tuberculosis, sanitation, and gender equality, although it is on track on extreme poverty reduction, access to basic secondary education, and access to improved water sources.

Life expectancy is 73.5 years for women compared to 65.3 years for men, and female literacy is high 97.7% (in the 15-24 age group). But despite progressive legislation on gender issues, women remain vulnerable to rising unemployment, a weak social protection system, and increased influence of patriarchal traditions in social relationships. Gender inequality, social and financial discrimination, and the additional unpaid work carried out by women mean that nearly 70% of the poor are now female. The continuing high prevalence of bride kidnapping in rural Kyrgyzstan remains a serious concern, and nearly 83% of women suffer domestic violence. In the government formed after the October 2010 elections, there were no female cabinet ministers until a lone woman minister for social protection was appointed on 7 April 2011. In those 2010 elections, representation of women in parliament fell from 30% to 20.8%, while in local councils it is now only 12%.

About 32% of Kyrgyzstan's population is between 15 and 25 years of age. Young people do not have full access to education, employment, health care, family decision making, and entrepreneurship. With inadequate educational training and poor economic prospects, many young people turn to crime and drugs. Young women, especially in rural areas, are particularly vulnerable to gender-based violence.

The country has prepared a medium-term Country Development Strategy (2012–2014) in the context of a macroeconomic outlook that looks challenging, but with potential for directing the economy on sustainable development. The Strategy focuses on creating conditions for attracting foreign investment, reform of state regulation aimed at eliminating bureaucratic barriers and expanding economic freedom of business entities, as well as on launch and implementation of 40 national projects in the medium-term. All these fundamental factors will be crucial for long-term sustainable human development and achievement of the MDGs.

1.9.2 Situation Analysis in the Healthcare System of the Kyrgyz Republic

Heart diseases are one of the leading causes of death and a major cause of disability. The importance of cardiology service is emphasized by the fact that cardio-vascular problems account for 50,3% in 2011 (48.3% in 2010) of all death cases in the Kyrgyz Republic.

The second alarming issue is the level of maternal and child mortality.

Child (infant) mortality is the crucial characteristic of national health. The child mortality rate is 20,7 per 1,000 born alive in 2011 (22,8 in 2010) and the structure looks as follows: the main share belongs to perinatal period conditions (65,2% in 2011, 63,1% in 2010, 60.0 % in 2007 and 60.9% in 2006), respiratory apparatus' diseases - pneumonia (12,3% in 2011, 14,9% in 2010, 16.7% in 2007, 17.5% in 2006), inborn anomalies (12,3% in 2011, 12,6% in 2010, 11.3% in 2007 and 11.2% in 2006) and infectious and parasitic diseases (5,3% in 2011, 4,5% in 2010, 6.8% in 2007 and 5.7% in 2006).

The major causes of such deaths are wrong diagnostics and incorrect prescriptions. The registration of child deaths at home shows that children die during the first five years of life because the parents are unable to properly evaluate the health status and do not know how to help. During the recent years the ratio of child's hospitalization caused by pneumonia has been high and made 36% for children up to five years, being one of the main death causes for children under 14.

In the last few years the maternity mortality rate has increased and in 2011 it made 49,3 per 100 000 live births (50,6 in 2010, 62,5 in 2007, 53,0 in 2006 and 60,0 in 2005). The leading place in maternal mortality

increase was taken by the Talas region -87,0 per 100 000 live births in 2010 (61,3 in 2009 and 38.5% in 2006), the Naryn region – 83,5 per 100 000 live births in 2010 (135,6 in 2009), the Issyk-Kul region – 70,4 per 100 000 live births in 2010 (72,0 in 2009), Osh region – 59,8 per 100 000 live births in 2010 (117,4 in 2009). Rural areas take the first place in terms of death cases among women (86.8%). The major cases of such deaths are wrong diagnostics. The maternity mortality structure shows that 75.0% of deaths happen during pregnancy and childbirth. The first place of the mortality rate is taken by haemorrhages – 52.2% (in 2007 – 34.4%), the second by hypertension disorders - 22.4% (in 2007 – 34.3%), septic complications account for 10.4% (7.8% in 2007).

Although the prevalence of HIV is still low, the country has registered sharp increases in the number of persons living with HIV, and suffers one of the fastest rates of increase of reported HIV infection in the world. As of end 2011, there were 3111 registered HIV cases in the country, although WHO estimates suggest the true figure may be two or three times higher. Children now make up 8% of HIV cases in the country, following an outbreak in hospitals in the south of the country in 2007 and mother to child transmission. Because of women’s vulnerability to HIV, sexual violence, inequality in decision making on contraception and sexual life, and poor sex education, the number of females registered as living with HIV increased by 75 times between 2001 and 2011, compared to 17 times for males. Despite progressive legislation, implementation mechanisms are weak and people living with HIV face continuing stigmatization. At over 12 cases per 100,000 people, tuberculosis prevalence is also high and rated as an epidemic. Much of the tuberculosis is multi-drug resistant, and the disease is particularly prevalent in the penal system because of overcrowding, poor ventilation, malnourishment and inefficient treatment. Meanwhile, an increasing proportion of tuberculosis cases are being registered among women and children. The prevalence of malaria, although still low, is increasing, particularly in southern parts of the country.

1.9.3 Objectives and Strategies

During the implementation of the National programmes on the healthcare reforms in the Kyrgyz Republic: “Manas” (1996–2005) and “ManasTaalimi” (2006-2011) the legislative base for the new health care system in the Kyrgyz Republic were established. The following new laws were adopted by Kyrgyz Parliament: on “ The unify payer in the healthcare finance system” (2003), “ About healthcare organizations in the Kyrgyz Republic” (2004), “Health protection of the citizens of the Kyrgyz Republic” (2005), “ Public health care in the Kyrgyz Republic” (2009), amendments to the laws on “About the main principles of the budgetary law in the Kyrgyz Republic” (2000), “ Local self governance and local governance administration in the Kyrgyz Republic”(2000), “Medical insurance of the citizens of the Kyrgyz Republic” (2003).

Every year, starting from 2001 the Government of the Kyrgyz Republic approves the Governmental Programme on State social guarantee provisioning free, preferential and paid terms of the healthcare services depending on the citizen’s social status and medical insurance conditions. From 2006 the health care reforms performs under the Sector Wide Approach (SWAP).

The current National Programme of the health care reform “Den Sooluk” for 2012–2016 is a logical continuation of the previous national programmes focused on the 4 programme’s directions:

- Cardio-vascular diseases;
- Maternal and child health care;
- Tuberculoses;
- HIV/AID.

The special focus in this programme was taken on the deployment of the ICTs in healthcare system from the view of standardization of the medical information systems and development of the unified telecommunication infrastructure. The implementation of the e-health services recognized as one of the main priority and includes the creation of the national e-health network for e-learning and tele-consultations.

Kyrgyzstan, as a country with difficult mountainous terrain needs the e-Health services because people in remote and rural areas have inadequate access to medical aid and health care. They have to travel for many hours to reach the nearest hospital or clinic. But to be effective, e-Health requires appropriate regulatory, legal and policy frameworks in both the telecommunications and the health sectors. Some of the critical factors for success are proper project management and a coordinated approach following the clear vision, the building up and maintenance of adequate technological infrastructure, the commitment of trained end-users and ICT literate citizens, and the political will to achieve challenging but realistic e-health goals.

Currently, Kyrgyzstan does not have a specific national strategy on e-health, which would require the initiative of the Ministry of Health together with other relevant Government agencies and CSOs. With the support of UNDP in Kyrgyzstan, the project on e-health in one of the remote areas (Batken) was implemented. UNDP is further looking at nation-wide project which would provide policy support and technical assistance toThe Ministry of Health of the Kyrgyz Republic, envisaging the following components:

Component 1: Draft National e-Health (including m-Health) Strategy & Action Plan developed and submitted for approval to the Kyrgyz Government.

Country's e-Health strategy will be based on national health priorities, the available and potential resources, and the current e-health environment. The enabling environment for e-Health is fundamental to scaling up and sustaining ICT adoption in the health sector. It includes aspects such as governance, policy, legislation, standards and human resources. Within the Kyrgyz Republic's national context, where the first pilot e-health project was implemented in 2009-2010 (joint initiative of UNDP, MTC and MH). This project featured a small initiative, within limited time-line, where advantages of using ICTs were demonstrated, including innovative ICT applications (with elements of m-health). The project was not sustainable due to the lack of ownership, commitment and e-health skills. In addition, it had a narrow focus on certain aspects of e-health, while the changes and overall approach in the health care system were required. A national plan for a country in this context will be focused on making the case for e-health, creating awareness and establishing a foundation for investment, workforce education and adoption of e-health in priority systems and services. Without a parallel focus on creating the enabling environment, innovations in ICT will stay isolated and have only a limited impact on health.

Mobile communications have arguably had a bigger impact on humankind in a shorter period of time than any other invention in human history. Mobiles are also contributing to social, economic and political transformation. According to new WB Report (2012) to human and economic development opportunities, around three-quarters of the world's inhabitants now have access to a mobile phone and the mobile communications. The number of mobile subscriptions in use worldwide has grown from 1 billion in 2000 to over 6 billion in 2012, of which nearly 5 billion in developing countries. In developing countries citizens are increasingly using mobile phones to create new livelihoods and enhance their lifestyles, while governments are using them to improve service delivery and citizen feedback mechanisms. Mobile communications can help provide health care services more quickly and cheaper in many cases, mainly by focusing on primary, preventive and self-empowered approaches to health care. M-Health encompasses any use of mobile technology to address care challenges such as access, quality, affordability, matching of resources and behavioral norms through the exchange of information. It is a dynamic field for innovative new services that move health care away from pure public service delivery toward seeing the patient as a consumer. The recent studies estimated that m-health reduces data collection costs by approximately 24 percent, costs of elderly care by 25 percent and maternal and perinatal mortality by 30 percent (Telenor Group 2012). The same study finds that m-health can improve compliance with tuberculosis treatment by 30-70 percent. Taking into account above, finally, M-health should be integrated with larger e-Health Strategy and Action plan.

Component 2: National Process for e-Health Standardization initiated, key technical standards developed/adopted and submitted for approval to the Kyrgyz Government.

Considering the rapid introduction of e-health worldwide and potential growth in Kyrgyz Republic it is necessary to initiate the development of generally acceptable the national standards and guidelines to

facilitate growth of e-health application in Kyrgyzstan. Enormous international efforts are being put in this direction to regulate/guide the growth of healthcare IT ecosystem. These efforts are the result of compelling need for the standardization of processes in which healthcare information is represented and transmitted from system to system. For any developing country to embark on proposing standards for e-health and Hospital Management Information Systems (HMIS) it is imperative to study the existing international standards. Many Standard Development Organizations (SDOs) and Special Interest Groups (Sigs) are active in standardization process for addressing the issues of sharing of health data, data structure, access management, standardizing clinical and business process in healthcare and security and privacy. Some of the key relevant standards such as ISO/TS 18308, CEN/TC 251 EN 13606, DICOM, HL7, CCR-ASTM, CEN/TC 251 EN 13940, ICD-10-PCS, SNOMED-CT, CPT, UNLS, ITU-T H.32x. For any developing country embarking on introducing standardization will benefit by going through the exercise of reviewing these available standards to see their suitability for adoption.

Component 3: National e-Health network (with national e-Health center/node) and mechanisms for rapid deployment of ICT-enabled public e-health services created and some public e-health services (on cardiovascular, maternal and prenatal healthcare) provided to the citizens of Naryn and Osh provinces of the Kyrgyz Republic.

Under this new project it is planned to create national e-health center (s)/node(s) equipped by different modern digital medical and telecommunication equipment, real-time management of medical records, broadband connection and adapted e-health software systems in national e-health center. These secondary and primary health centers in Naryn and Osh provinces of the Kyrgyz Republic to enable continuous medical education and tele-consultation will be also established. Webcasting of the interactive courses by leading medical professionals to university students and young professionals in remote areas will be provided as well. Tele-consultations using an integrated system capable of managing patients, storing and forwarding medical records and images and providing second opinion to remote patients will be held. The system will comply with international standards adopted and approved by Kyrgyz Government. Some e-health services in cardiovascular, maternal and prenatal areas will be operational for Naryn and Osh province's patients.

1.9.4 Activities Implemented

UNDP Kyrgyzstan jointly with the Ministry of Health and Ministry of Transport and Communications of KR has successfully piloted in 2009-2010 the first e-health project in the Kyrgyz Republic in the remotest region of the country - Batken province, which lacked medical personnel, health services and special medical equipment. Two leading national medical institutions participated in this first e-health project. Medical receiving stations installed in these institutions and remote equipment for transferring the medical data were provided to the regional hospital. 24/7/365 help was arranged at the national centers with high professional medical staff in order to provide ON-OFF medical support with diagnostics and prescriptions. Different types of telecommunication and special medical equipment installed to ensure high quality communication of all necessary medical information to the both ends. Local population had access to health services at their place of residence.

The main objective of the project was to create and implement the first interactive E-Health services in the Kyrgyz Republic in order to decrease the mortality rate, especially on cardiovascular and maternity & child healthcare and to promote effective use of ICT as a powerful instrument for governance, economic and social development, citizen's access to public information and government services. E-Health services are considered as a component of the E-Government implementation in the social sector, which is an effective tool for improvement of health care service delivery through use of modern ICT technologies, especially in remote rural areas with focus on women and children and contributes to MDG 4 and 5 achievements.

1.9.5 Changes and Results Achieved

The project produced the following outputs:

- Access to public medical services was improved for populations in remote rural areas.

- Distance medical services for remotest region (tele-cardiology as well as maternity and child health care) were established.
- ICT possibilities in the healthcare area on provision of different medical services were demonstrated.
- Qualification of local medical personnel was improved through professional and IT-trainings.
- The project's idea and results were presented on round table with participating of the Vice-prime Minister of the Kyrgyz Republic and all interested stakeholders- Government entities, NGO's, mass media, universities and others. Very positive feedback received from all parties. Based on a result of this pilot project, the Ministry of Health of KR developed and submitted the document requesting budget from Government of sharing the best practice in order to implement the project's idea in all other regions of KR.
- The project was also presented at the SWAP meeting – regular biannual meetings of international donors, investing in healthcare sector of KR. It was the request from the Ministry of Health of KR (from state-secretary of the ministry) to mobilize additional resources for extension of the project to other regions of KR.
- The information about project was placed in DG TTF 2009 Annual report as best practice example (Democratic Governance Thematic Trust fund Stories from the field).

1.9.6 Lessons Learned

- The project's idea and suggested technological solutions are practical and can be easily replicated in other regions of the country and even more – in other countries with similar geographic and socio-economic conditions.
- State ownership: there was a high degree of commitment of key stakeholders during the project implementation. The Ministry of Health, despite the frequent changes of the departmental heads, remained interested in the project and expressed the intention to sustain project results. Middle managers were included as facilitators in the technical working group, have consistently advocated to the senior management the expansion of the interactive electronic medical services through the inclusion of this thematic area in the SWAP strategic objectives.
- Not all modern digital medical diagnostic equipment could transfer its data outside of the device using Bluetooth or USB ports and allow to connect to third party (not own) software.
- Lack of practical experience and knowledge on e-health not only in Kyrgyzstan and the Central Asia region.
- The lower level of preparedness and competences of the local medical personnel to use the computer and modern medical diagnostic equipment.
- Latent resistance (or skepticism) from doctors (rural and central) to accept new way of providing medical services.
- Lack of involvement of NGOs in the project activities. The project document envisaged NGO stakeholders in the steering committee, which however were not able to provide necessary contribution.
- Prior to the project commencement, there was no proper stakeholder and institutional analysis made. This impacted project implementation results.
- Strategies for engagement and cooperation of donors in this area need to be developed and the Government should play a central role in coordination and facilitation of this process.

1.10 Laos: E-Health Activities by Fujitsu, JTEC and Laos Government

1.10.1 Project Information and Background

¹¹In Lao P.D.R., the Ministry of Health, headed by the Minister, has the strong intention to utilize ICT in the health and medical fields, and the “ICT Master Plan (ver.1) for MOH” was established in October 2008.

The e-Government Network, led by the National Authority for Science and Technology, which is to be commonly utilized by all the government ministries and agencies, is put into operation mainly in Vientiane capital and under expansion to provincial capitals.

For the Ministry of Health, it is vital to introduce e-health applications in an effective and efficient manner to realize the aforementioned ICT Master Plan by utilizing the ICT infrastructure in e-Government Network.

Thus, in order to effectively promote the ICT application in the health and medical fields, the collaborative research team of Japan and Lao P.D.R. has conducted the study on the scheme and methodology of “How to develop, maintain, and utilize the comprehensible e-health contents” under the support of APT

(EBC-J2) scheme – 2008.

1.10.2 Summary and Purpose of this System

The results of the collaborative research are fruitful and there are high interests and demands for the realization. Therefore, as the practical and sustainable way forward, the pilot project under the support of APT (EBC-J3) scheme – 2009 has been implemented with the purposes of:

1. Establishment of ICT Access Points for proper information provision to the public (especially health and medical information) by expanding the existing e-Government Network.
2. Deployment of the ICT facilities available for (but not limited to):
 - Remote consultation between Central Hospital and Provincial Hospital.
 - e-Education for doctors, nurses, and other medical staff.
3. It is highly expected the pilot project would be:
 - the best practices of ICT based improvement for health and medical field;
 - the best practice of effective utilization of e-Government network;
 - paving the way for the Network expansion into rural areas.

● Network overview

As shown in Figure 6Error! Reference source not found., the dot line area shows the part installed in the pilot project. Main part is the IP Microwave Radio System to provide connection for Luangphabang Provincial Hospital in order to connect to the e-Government Network led by the National Authority for Science and Technology. The two hospitals in the map placed at the bottom right of Figure 6 are connected through the e-Government Network.

● System overview

Figure 7 shows the system overview of the pilot project. In Mittaphab Hospital, Main Server for Web Video Conference System and File Server, and 2 client PCs are installed. Back-up Server for secured

¹¹ Contribution: Go Maeno, FUJITSU LIMITED, Japan. See document [RGQ14.3.2-INF-0019](#)

system operation is located in Ministry of Health headquarters. In Luangphabang Provincial Hospital, 2 client PCs and 1 PC for Open ICT Access Point are installed.

Figure 6: Network overview of the pilot project

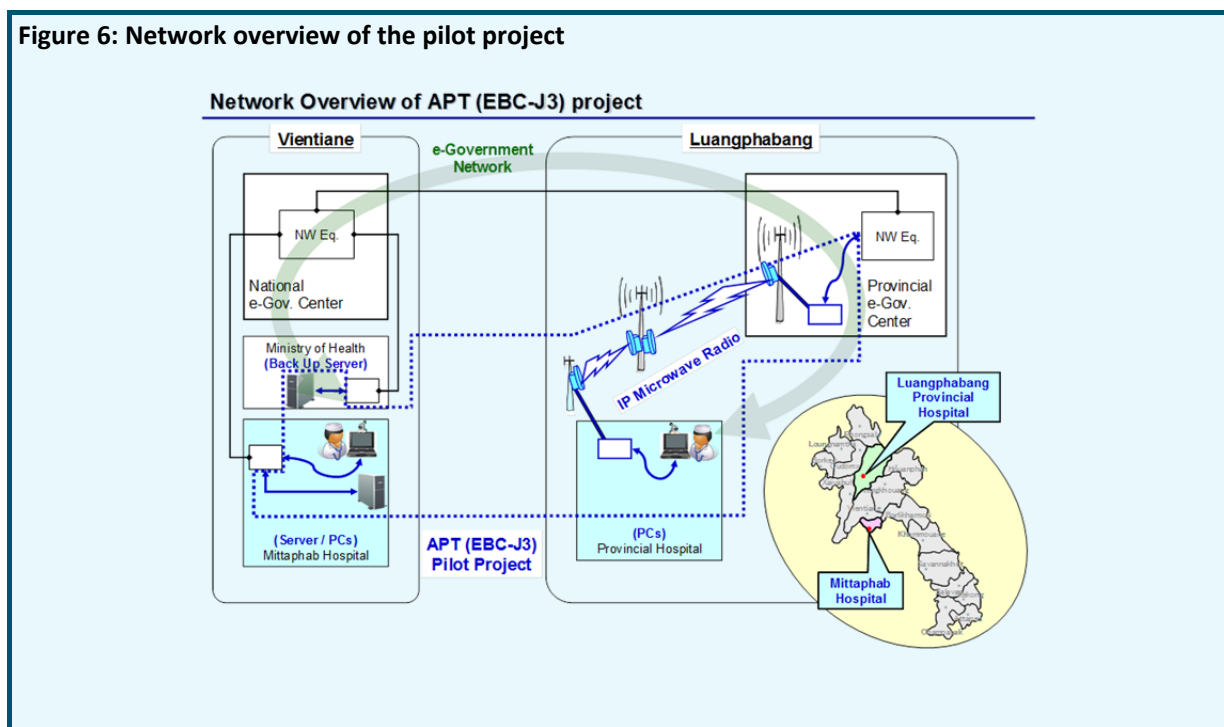

For Remote Consultation between doctors, the Web Video Conference System is used for the more understandable communication. Also, document files such as Consultation Reports can be shared through the File Server.

For e-Education, the contents stored in the File Server can be accessed remotely. In addition, the recording function of the Web Video Conference System is quite useful. For example, seminars can be recorded in synchronization with the slide show and explanation for them.

Public who visit the hospital can access health information easily from the ICT Access Point located at the lobby in Luangphabang Provincial Hospital. In addition, automated data synchronization is activated between Main and Back-up Servers. In case of server trouble, system availability can be kept by switching the connection to the Back-up Server.

1.10.3 Major Implemented Items

Major implemented items under the pilot project:

- IP Microwave Radio System has been installed to expand the e-Government Network to the Provincial Hospital.
- Central Database has been assembled for compiling medical contents database, including back-up system.
- Web Video Conference System has been installed.
- Open ICT Access Point to the public has been established in the Provincial Hospital.

Figure 7: System overview of APT (EBC-J3) project

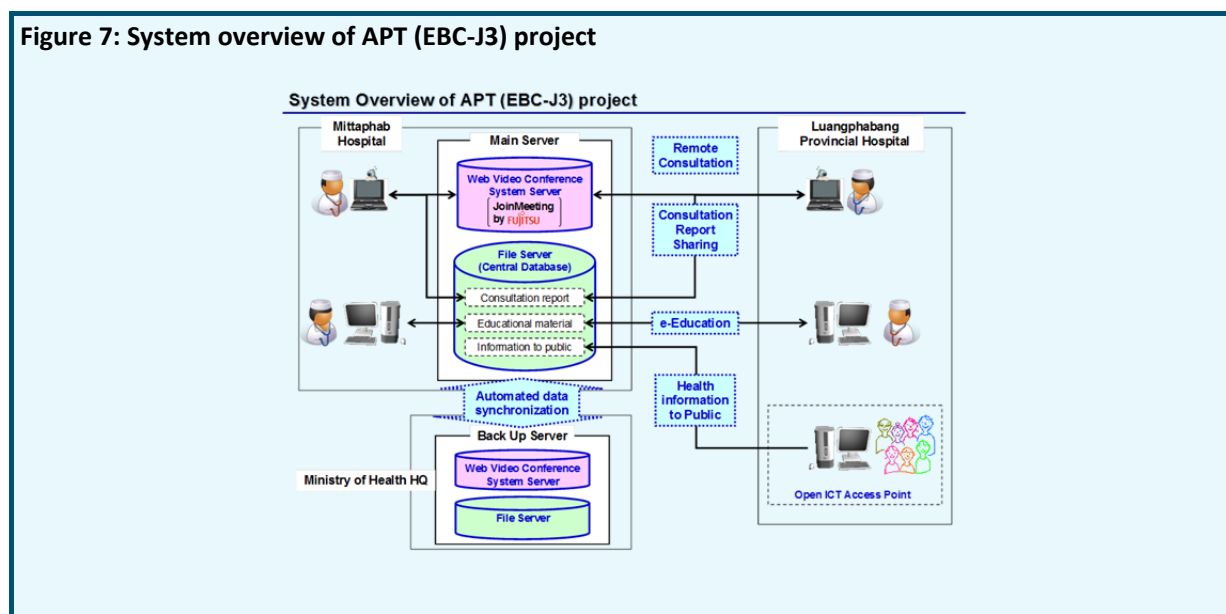

With the system installed, the ICT environment for project sites was improved.

1.10.4 Effectiveness

As a result, we have ready conditions for more understandable communication for Remote Consultation, compensation for the insufficiency of practical training, and provision of proper information to the public with full system installation and continuous utilization. Our aim “improvement of health and medical environment with ICT for rural areas” has just been achieved as the pilot case in Lao P.D.R.

1.10.5 Conclusion

Starting from the establishment of the ICT Master Plan for Ministry of Health, our 3-year continuous activities on the pilot project have come to a conclusion. However, the conclusion of the pilot project is not the goal, and we have the strong intention to step forward to the practical deployment of ICT in health. The system installed reflects the real need to fill the gaps between demands and the actual situation. Thus, the success of the pilot project would be paving the way for the expansion to other provinces and the establishment of nationwide networks of e-health.

As the next step, we will make a comprehensive review on the concluded activities to ensure Roadmap & Action Plan for Practical Implementation, Practical solutions for the identified issues, [Namely, more practical work than theoretical]; Skilled personnel for sustainable enhancement.

These are indispensable for the practical deployment of ICT in health. Therefore, we are applying for the APT (EBC-J2) 2010 program and will keep our close relationship with the current project member organizations. Also, we have set our sights on best practice sharing with other sectors in Lao P.D.R. and with other countries.

Our further target is to formulate the practical project for ICT enhancement in not only Lao P.D.R. but also other developing countries.

1.11 Lebanon: E-Health in Lebanon – Where Do We Stand?

1.11.1 Introduction

¹²This document is based on a recent report¹² that was the outcome of a project funded by the World Health Organization (WHO) in Lebanon for developing a national e-health plan. The purpose of the project was to illustrate the current e-health status in Lebanon. The areas assessed were the existing and planned e-health applications and services, the available/potential information communication technology (ICT) infrastructure for e-health, the human resource capacity, standards and interoperability, e-health strategy and investment, e-health legislation, policy and compliance, and Governance. The assessment is used to establish near term opportunities for e-health projects, and to explore possible actions to be undertaken in developing a comprehensive national e-health implementation strategy for Lebanon in the near future.

1.11.2 Country Overview

In Lebanon the economic, social and political forces have been exponentially influencing the healthcare sector for a number of years, hindering the implementation of any new health model or strategy. So far in Lebanon e-health is suffering from a low profile even though e-health has increasingly large impact on healthcare. There is a lag in uptake of e-health because the field needs more professionally trained staff on board. The social environment is having an undeniable influence on consumers; there is still a portion of the Lebanese community who are not yet accustomed to the use of Internet-mediated electronic means for the provision and management of health services. Moreover, the preference of face to face meetings for assessment, treatment and consultation may negatively influence the development and implementation of e-health technologies and applications.

Promoting the use of information technologies in healthcare is one of the defined priorities in e-health implementation. Article 5 of the Telecommunications Law 431/2002 specifies that among the duties of the Telecommunications Regulatory Authority (TRA) is “to assist educational and health care institutions in the implementation of their programs by the use of Telecommunications Services, and to facilitate the access of disabled persons to Telecommunications Services.”

As for the use of standards, there are no e-health standards/policies/standardization being implemented at health institutions that make the physicians comply with e-health practices. The lack of standards influences the deployment of e-health practices on a large scale and creates gaps that hinder the benefits from using ICT, mainly its potential in improving care and sustaining cost. In addition, the lack of metrics for measuring successful deployment of e-health are also hindering improvement.

The Ministry of Public Health (MOPH) in Lebanon is concerned with the public health issue more than the e-health per se. According to the General Director, since there are no geographical barriers or lack of specialized doctors in the country, telemedicine is not a target at this point so far. The priority for the MOPH is to have better managed care, better epidemiological reporting, e-billing, and e-pharmacy.

Currently there is no national policy in the country that commits healthcare institutions or clinics to implement Electronic Health Records (HER). Furthermore, the existing e-health applications in health institutions lack the interoperability with the MOPH’s health information systems. In this regard the institutions are not having the full benefits behind the deployment of e-health applications. As for monitoring activities, innovative systems and services for monitoring the health status of people at risk or those suffering from any chronic illness including those associated with ageing, wearable, portable or implantable systems are used. These systems can offer the means to follow patients’ health outside the health institutions. However, very few institutions are able to manage diseases and develop early diagnosis of symptoms from a distance. As for ICT infrastructure, the deployment of a proper ICT infrastructure that demonstrates the benefits of e-health services on a larger scale in the country does not

¹² Soha Saifeddine, Telecommunications Regulatory Authority, Lebanon. See document [SG02-C-0210](#)

exist so far. So far the ICT infrastructure has been implemented within some health institutions at various levels to communicate data across the same institution and never across other institutions. In addition, the required ICT infrastructure to create a database for patients' records in health institutions is not up to the level for e-health practice and therefore needs further development.

1.11.3 Activities Implemented

The key trends and developments in the e-health domain in Lebanon, aiming at improving the quality of healthcare, can be classified into the following categories:

- **Physiological monitoring activities**

Physiological monitoring activities are the most used e-health applications in Lebanon. Medical institutions use various systems for monitoring activities such as screens connected to cameras and other monitoring apparatus for inpatients only.

The Ministry of Public Health has implemented the monitoring systems for medications and vaccines distribution and storage. The system allows identification of the medication or vaccine expiry date five days in advance. Also the system will notify about temperature change in the storage media via alert systems connected to the mobile device of the manger. That system was implemented in 2006 in collaboration with the WHO.

The availability of body area networks (BAN) and e-health applications will allow the practice of vital sign tele-monitoring of chronically ill outpatients. Such type of monitoring is not available in Lebanon, very few hospitals provide only cardiac tele-monitoring with the use of holter.

- **Diagnostic evaluations**

The use of diagnostic evaluation tools is limited to the laboratories and radiology departments such as (MRI, PET scan, CT-scan etc...).

An example of a successful development is the Lebanese Ministry of Public Health (MOPH) Mobile Applications.

1.11.4 Lebanese Ministry of Public Health (MOPH) Mobile Applications

The mission of the Lebanese Ministry of Public Health is to improve the health status of the population by ensuring an equitable accessibility to high quality health services through a fairly financed universal coverage.

MOPH' main goal is to protect the population' health through the legislation and development of health promotion and preventive programs, to contribute to the social safety net, eradicate and control the communicable and non-communicable diseases prevalent in Lebanon.

In order to reach these mission and goals, the MOPH launched a unique, one of a kind Mobile app and the first in the Lebanese public sector; aiming to facilitate the cooperation with other ministries, private sectors and the civil Society.

The main objectives of the App are:

1. To develop the health sector and to improve the quality of health care delivery through the use of information and communication technology.
2. To increase transparency through the dissemination of health-related information.
3. To facilitate access to services delivered by using the best and fastest possible electronic means.
4. To increase the accountability through the adoption of a mechanism for complaints.
5. To ensure equity in services' availability and utilization.

Main Functionalities:

Users have direct access to the Drugs Public Price List; they can check their availability, price and legalization in the Lebanese pharmacies. They may as well locate the nearest public hospitals, private hospitals and medical centers, check their full address & call directly from the app.

Users may as well benefit from health info and learn about healthy life-styles and food habits. People and communities can now seek greater and effective participation in the planning, implementation and evaluation of primary health care and public health programs; and report fraudulent actions directly to the Ministry of health through the app. All app users will receive alerts on news, drugs recalls, laws etc. from the ministry.

Main Features:

- Drugs list (check price, dosage, form, legalization ...).
- Rules and Guidelines concerning MOPH disbursed expensive drugs and chronic diseases drugs.
- Public/Private Hospitals and Primary Health Care Centers Directory.
- Ministry of Health services and campaigns.
- Report fraudulent actions directly to the Ministry of Health.
- Healthy tips on lifestyles and habits.
- Push notification.
- Media Gallery (Ministry Activities & events).

About MOPH: Latest News, MOPH Portal, Locate us, MOPH Directory, call center (1214)... MOPH is available for free to download in the [iTunes Store](#) and [Android Google Play App Store](#).

Figure 8: MOPH is available for free to download in the iTunes Store and Android Google Play App Store

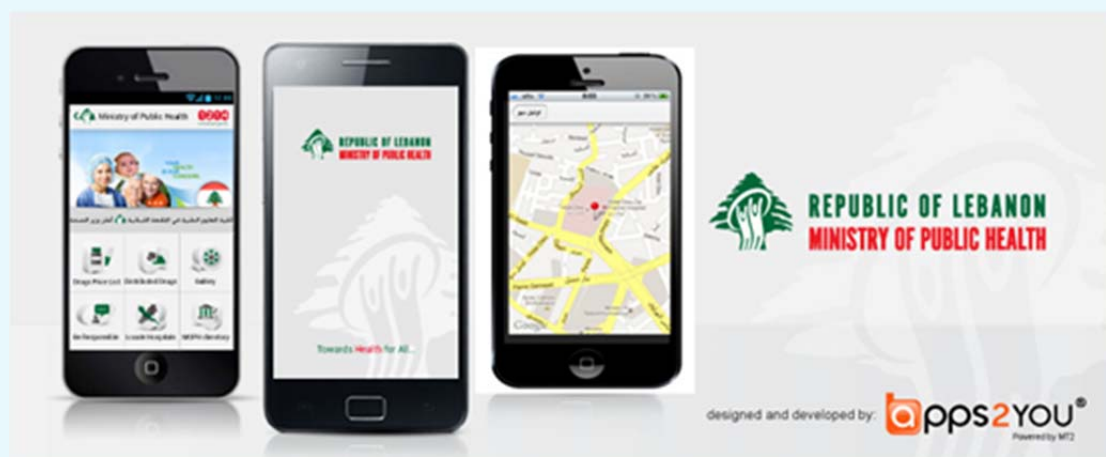

Clinical decision support system

Clinical computerized decision support systems (CDSSs) which are meant to help address the problems of variable quality and safety in health care, are available in some institutions but mainly limited to laboratory findings and very few to medication administration. The available systems allow comparison between normal and abnormal laboratory findings only upon highlighting the abnormal level in order to grab the attention of healthcare providers.

Storage and dissemination of healthcare data

The first step towards e-health is to create the backbone- the electronic health record (EHR). The EHR will ultimately link all patient information from across the health care system, hospitals, private clinics, pharmacies, and elsewhere healthcare is being provided to individuals.

In some health institutions in Lebanon, patients' health records are being scanned and then stored in digital form as image files. Then patients' records are stored under their ID numbers per hospital visit and listed by date.

Image compression for efficient storage and retrieval: Picture Archiving and Communication Systems (PACS)

The use of Picture Archiving and Communication Systems (PACS) can improve diagnostic radiology. PACS's main purpose is to replace hard film copies with digital images that can be used and seen by several different medical professionals simultaneously. The use of PACS is being practiced at a number of health institutions in Lebanon.

Research:

- Research on e-health practice:

Research on e-health practice can contribute to the overall understanding of the e-health domain and its impact on quality care. Very few health institutions in Lebanon are currently practicing research on e-health.

- Clinical research:

The practice of clinical research can contribute to the overall understanding of the health system in the country and how it is changing. In order to carry out this work, a large amount of aggregate clinical data on the health system is needed. The competencies available to supply this data include data aggregation, data communication and statistical analysis.

In Lebanon, a small number of health institutions practice clinical research in their institutions. As a matter of fact, research needs improvement as the access to clinical data is restricted to administrators and very few clinicians. Furthermore, Health data are being stored as image files which limits data processing and impedes search by computer engines, and therefore creates a barrier to clinical research.

Computerized provider order entry and e-Prescription

Very few health institutions in Lebanon are using Computerized Provider Order Entry (CPOE), a computer system that allows for the direct entry of medical orders by healthcare providers. The CPOE system enables physicians/healthcare providers to check medication and health procedure orders for incorrect drugs, doses, and routes of administration, as well as for any allergies and drug interactions. If the computer system detects any of these problems, an alert is generated to make the provider aware of the issue. The primary goal of CPOE is to reduce medication errors, and enhance communication among healthcare providers to increase patient safety.

As for e-prescription, it is not a trend so far in Lebanon. Most of the health institutions do not have the CPOE or the electronic prescriptions launched yet. Very few institutions practice electronic prescriptions for restricted antibiotics only. Therefore, all health institutions are still using the traditional paper medical chart. For some institutions that are having difficulties with regards to archiving space, they resolved this problem by scanning the patients' charts and storing them as digital images.

Voice recognition for dictation

Voice recognition for dictation is not available at any health institution in Lebanon. What is being practiced in few hospitals is that the doctor records his/her medical report on a tape recorder and then the report is typed by a clerk and filled electronically.

Use of Streaming media in health care institutions

The continuing education of healthcare providers is required for better practice, whereas education of healthcare consumers is necessary for health promotion and better management of patient's own health. Very few health institutions in Lebanon use streaming media such as video sessions, power point

presentations, e-pamphlets for educational purposes to both healthcare providers and consumers. Some institutions have made the educational material accessible from their websites to promote access. The use of streaming media has eased the dissemination of the educational material; also it helped in managing the continuing education (CE) credits for healthcare providers.

Ministry of Public Health's (MOPH) initiatives to promote and support e-health practices

- **TWFS (Transactions and Workflow System):**

The objective of this system is to automate the workflow, track and monitor the transactions and documents involved in the procedures of the Ministry of Public Health's administrative units.

The system is expected to provide user-friendly, secure and reliable methods of performing and tracking all the processes and procedures along with the associated forms utilizing a flexible, quick and easy to use tracking, monitoring and reporting mechanisms that will empower the MOPH administration in performing its duties and functions with minimal effort, high efficiency and productivity. It will also relieve citizens from the burden of administrative procedures and provide them with a better and faster service.

The system allows visitors to the MOPH's website to benefit from the below services:

Administrative Services:

- Search for a specific service through the organizational structure of the ministry.
- Have access to all details related to the service required: the unit responsible of this service, the head of unit, the required documents, the conditions, the fees, the duration of the procedure, working days ...
- Download a pdf application form or fill an interactive pdf application.
- Submit on-line transactions with attached documents.
- Login to the website using a Document ID and a Password in order to track and retrieve all the information related to the status of the transaction, and send any comments about this transaction to the related department

Drugs:

- Download the complete list of drugs with their public prices based on foreign currency rates and according to Resolution 51/1 issued in 2006.
- Search for drugs using different criteria: Drug's name/Laboratory/Agent/Country of origin.
- Search for drugs that have been recalled from the Lebanese market.
- View the list of registered drugs according to INN classification (First draft): Ongoing project.
- Check the Lebanese National Drug Index which is a simple verified listing and classification of available products in the Lebanese market.
- View all the information related to the Drugs technical committee including meeting schedules & agendas, the list of applications submitted for Drugs Registration, the Resolutions taken by the committee regarding the registration of medicines @MOPH...
- An instant notification e-mail is always sent to concerned parties when publishing any new information related to Drugs.

Doctors Fees:

Physicians who are treating patients on the expenses of MOPH can login to the website using their credentials to access all details related to their payments from MOPH using an advanced tool for searching and reporting .

- **Decentralization Systems: District Health Information System:**

This is a tool to monitor diseases and their spread over different areas allowing the ministry's officials to plan for intervention and activities in an appropriate and timely manner.

- **Visa System: This system started on May 19, 2003 at the MOPH's visa center. It:**

- Allows 25 regional visa centers to connect remotely to the MOPH's database using web technology and to MOPH's users through LAN technology.
- Creates a unified patient medical file, independent of the treatment place and visa issuing center.
- Allows the MOPH to view the history of every patient's file.
- Automatically rejects patients who benefit from other public funds (Army, ISF, NSSF, CSC).
- Creates a unified applicant's file to control the frequency of the requests submitted per applicant.
- Retrieves accurate statistics to help managers to take appropriate decisions.

- **Billing System:**

- Allows contracted hospitals to connect remotely to the MOPH's database using web technology.
- Bills are entered by each hospital.
- Provides information about bed occupancy status by hospital: the allowed number of beds/day v/s the occupied number of beds.
- Used as a tool for quality control.
- Provides admission diagnosis v/s discharge diagnosis, diagnosis v/s procedures etc... .

- **Interconnecting System:**

This system allows the MOPH and other public funds, namely the Army, the Internal Security Forces (ISF), the National Social Security Fund(NSSF) and the Civil Servants Cooperative (CSC), to share information about eligibility in order to avoid eligibility overlapping and double coverage. The main functionalities of the system are:

- Building a database (@MOPH) for beneficiaries in different public funds (Army, ISF, NSSF & CSC) containing demographic & eligibility information.
- Providing electronic linking of the beneficiaries databases in different public funds to the MOPH Interconnecting database.
- Performing a daily update of the Interconnecting database by establishing an automatic connection with public funds and downloading files containing updated beneficiaries information.
- Giving the public funds remote access to the centralized MOPH database for searching purposes.
- Is integrated with the Visa/Billing systems.

- **Human Resources for Health – HRH:**

The HRH system manages personal and professional data for human resources working in the health sector in Lebanon. Through this system, the MOPH now owns a database including personal and professional data for all health professionals in Lebanon except for specialized physicians and Dentists.

1.11.5 Challenges, Main Barriers and Difficulties for the Development of E-health in Lebanon

- **Governmental Barriers:**
 - Lack of national plan for the e-health practice in Lebanon.
 - Absence of e-health policy and standards.
 - The health sector is influenced by many underlying factors in the country, such as political instability, privatization control, and political power.
- **Institutional Barriers:**
 - The high cost of technology that most of the institutions cannot afford in the lack of funding resources (such as the absence of external financial support), in addition to budgetary constraints.
 - Reluctance to change from the traditional health practice to e-health practice.
 - Lack of qualified e-health professionals and training in the use of new technologies.
 - Lack of collaboration between the private and governmental healthcare organizations/institutions.
 - Lack of leadership and expertise for e-health practice (policy makers, managers).
 - Lack of interoperability in e-health practice.
 - Lack of collaboration among public and private institutions in the health sector.
 - Lack of awareness about e-health benefits in healthcare practice.
 - The need to update the administrative and organizational structures of existing health institutions.
 - Lack of health information websites.
- **Socio-cultural Barriers:**
 - Patients' preference of the face to face meeting and interaction with the healthcare provider.
 - Lack of patients' awareness about the benefits of e-health practice.
 - Lack of computer literacy among some patients mainly older patients.
 - Poor internet or lack of internet access especially in villages and remote areas.
 - Fear of e-health failure in a politically unstable country.
 - Electronic signature is not legalized yet by the government.
 - Complexity of the Social Security System dealing with public health insurance.

1.11.6 Lessons Learned, Next Steps and Recommendations

Efficiency in healthcare provision, provision of quality care, reaching the underserved population, and minimizing medical errors are the main driving forces to the implementation of e-health in the country. E-health practice will improve patient safety, reduce healthcare cost, allow better healthcare

management, allow better disease management, and solve the problem of shortages of healthcare providers in Lebanon.

The priorities to for successful e-health implementation are:

- National/Government level:

Compose a National e-health policies and strategies Committee in Lebanon. This committee will be in charge of:

- Establishing a 5-year e-health strategy plan to advance the use of information technology all over the health sector.
 - Dealing with the local e-health strategic planning including infrastructure, funding, policy and governance of e-health practice, besides collaborating with International e-health foundations.
 - Developing e-health competency framework to guide and help ensuring sufficient skills for various healthcare professionals, who should be also adequately prepared to train other healthcare providers.
 - Establishing a national forum that:
 - Promotes the use of telecommunications and related technology in the delivery of health care and health education in the country.
 - Facilitates and assists various healthcare organizations in developing secure and private electronic health records for the Lebanese citizens and makes health information available electronically whenever and wherever it is needed.
 - Serves as a forum for advocacy, communication and sharing of resources among communities of interest.
 - Raising awareness among the various stakeholders about the opportunities in the e-health sector in Lebanon.
 - Assisting healthcare facilities in securing the needed funds for e-health implementation from national and international resources.
 - Considering innovative financing and compensation schemes for e-health services.
 - Including e-health concepts in medical and nursing curricula.
 - Legalizing electronic signature and making it lawful by the Lebanese government in order to encourage healthcare institutions and insurance companies to promote e-health practices and data protection and liability through the development of guidelines and codes of conduct for e-health services.
 - Putting more emphasis on international cooperation in order to promote benchmarking and evaluation projects that can provide evidence to support the deployment of e-health practices.
- Ministry of Public Health Level:
 - Initiating the Electronic Health Record (EHR) system and facilitate the communication of health data between the private and public health sectors.
 - Encourage national research in e-health practices.
 - Collaborate with healthcare industry organizations such as the Health Information Management Systems Society (HIMSS).
 - Collaborate with professional communities such as the American Health Information Management Association (AHIMA).

- Establish standard national educational programs towards preparing qualified healthcare providers who are proficient in e-health practices.
- Establish standards for e-health practices while benchmarking with international standards.
- Establish a Pharmacies Network for E-prescription.
- Encourage collaboration between private and public/government healthcare organizations.
- Healthcare Facilities Level:
 - Follow the national standards, which should be developed by the MOPH.
 - Maintain confidentiality and security of electronic health data.
 - Facilitate proper access to patient records for authorized personnel.
 - Allow online access to lab and diagnostic results (X-rays, CT scans and MRIs) for patients and healthcare providers as needed.
 - Utilize the Pharmacies Network for better medication prescriptions.
 - Establish interoperability of e-health applications in health institutions with the MOPH's health information systems.

1.12 Mali: La cybersanté au Mali – des projets pilotes à une institutionalisation réussie: leçons apprises et perspectives de passage à échelle

1.12.1 Introduction

¹³Chaque année plus de dix millions d'enfants de moins de 5 ans meurent de maladies prévisibles telles que la pneumonie, la diarrhée et le paludisme. Un grand nombre de ces décès est dû à des causes indirectes entre autres les guerres et le VIH/SIDA. La malnutrition, le faible niveau d'hygiène, le manque d'eau potable et des soins sont incriminés dans près de la moitié des cas. Environ cinq cent mille femmes meurent pendant la grossesse, la plupart pendant l'accouchement ou dans la première semaine du postpartum.

Le Mali est l'un des pays ayant les taux mortalité infantile et maternel les plus élevés dans le monde soit respectivement 196 pour mille et 464 pour cent mille. Huit femmes meurent chaque jour des complications de la grossesse. Près d'une femme sur deux n'ont pas bénéficié de soins prénataux. Plus de 59 pour cent accouchent à la maison sans l'assistance d'accoucheuses qualifiées. Environ un enfant sur cinq meurt avant la célébration de son cinquième anniversaire. Les causes de décès des moins de cinq ans sont principalement les conditions néonatales (26%), la pneumonie (24%), la diarrhée (18%) et le paludisme (17%). Un enfant sur deux meurt de sous-alimentation et beaucoup sont malnutris.

L'accès aux soins essentiels n'est pas équitable au Mali et le taux de couverture sanitaire reste faible. Près de 8 décès sur dix des moins de cinq ans surviennent à domicile.

Selon les principales conclusions issues du Rapport de Suivi de la mise en œuvre des OMD au Mali 2010, il est invraisemblable que pour le pays d'atteindre les objectifs 4 et 5 du millénaire en 2015.

Pour combler son retard dans la mise en œuvre des OMD, le Gouvernement du Mali a élaboré le programme de l'Initiative d'accélération des OMD dans les 166 communes les plus vulnérables. Parmi les stratégies adoptées figure celle l'intégration des services essentiels pour la mère, les nouveau-nés et les moins de cinq ans au sein même de la communauté spécifiquement dans les zones éloignées et

¹³ Contribution: Ousmane Ly, Agence Nationale de Télésanté et d'Informatique Médicale (ANTIM), Mali. See document [SG02-C-0186](#)

défavorisées proposée par l'UNICEF. Il s'agit d'une stratégie qui intègre à la fois les soins à domicile, le porte à porte, l'approche communautaire et les structures sanitaires.

Le défi est aujourd'hui est d'améliorer la réactivité du système de santé malien afin qu'il puisse assurer une équité et une accessibilité à tous aux services et soins de qualité spécifiquement aux femmes enceintes et aux enfants de moins de 5 ans.

Pour faire face à de défi, malgré la précarité des moyens, avec le plus souvent l'inaccessibilité géographique, l'insuffisance des infrastructures (routes, électricité), et la lenteur de la collecte de données (due au facteur temps, l'utilisation du papier, la lenteur de la remontée de l'information, etc.) il est important, voir indispensable de mettre en place une stratégie qui soutient un mécanisme permettant en temps réel:

- de suivre et d'évaluer les actions,
- d'apporter l'expertise pour la fourniture des services et soins de qualité,
- et d'assurer le renforcement des capacités des Ressources Humaines (RH) à distance.

L'une des solutions à portée des mains est l'utilisation des TIC appliquées à la santé: la Cybersanté.

Dans le but de promouvoir une utilisation judicieuse et efficiente des TIC dans le système de santé, l'Agence nationale de télésanté et d'informatique médicale (ANTIM) a été créée en 2008 sous la tutelle du Ministère de la santé par les autorités maliennes.

1.12.2 Aperçus du Pays

Le Mali est un pays continental situé au cœur de l'Afrique de l'Ouest. Il a une superficie de 1.241.238 km². Il est subdivisé en 8 régions administratives (Kayes, Koulikoro, Sikasso, Ségou, Mopti, Tombouctou, Gao, Kidal) et le District Central de Bamako qui a rang de région. Bamako est la capitale et compte environ 1.100.000 habitants.

Les régions sont subdivisées en cercles qui se répartissent en arrondissements. Dans le cadre de la décentralisation, au niveau local, le Mali compte 703 communes dont 684 communes rurales et 19 communes urbaines y compris les 6 communes du District de Bamako.

En 2010, la population est estimée à 14 500 000 habitants avec un taux d'accroissement intercensitaire de 2,2%. La majorité de la population du pays réside en milieu rural (73,2%). La situation sanitaire de la population du Mali, reflet du niveau actuel de développement socio économique, connaît aussi des améliorations significatives. Les dépenses totales de santé sont passées de 109 milliards en 1999 à 165 milliards en 2004 (CNS 1999-2004). Ces dépenses de santé proviennent essentiellement du financement direct des ménages (57%), des fonds publics (18%) et des fonds extérieurs (13%). Pour la période 1999-2004, les niveaux de morbidité et de mortalité du Mali restent parmi les plus élevés au monde et cela s'explique surtout par:

- une insuffisance des ressources financières allouées au secteur au regard des besoins de la politique sectorielle et du Programme quinquennal de Développement Sanitaire et Social (PRODESS);
- un environnement naturel insalubre et propice à la transmission des maladies infectieuses et parasitaires du fait d'une hygiène individuelle défectueuse et des comportements très souvent inadéquats face à l'environnement;
- une insuffisance de l'accès des populations à l'eau potable;
- des habitudes alimentaires sur le plan nutritionnel qui ont pour conséquence des apports nutritionnels non équilibrés et déficients aussi bien en quantité qu'en qualité (fer, iode, vitamine A), ce qui provoque des maladies et des carences;
- la persistance de certaines coutumes et traditions souvent néfastes pour la santé;
- un faible niveau d'alphabétisation, d'instruction et d'information de la population;

- une insuffisance en nombre et en qualité du personnel sanitaire et social.

Le Mali est classé selon l'OMS parmi les pays présentant une pénurie aiguë de personnel de santé, cette faible démographie se traduit par:

- 1 médecin pour 14.612 habitants (norme OMS 1 médecin pour 10.000);
- 1 infirmier d'État pour 18.145 habitants (norme OMS 1 pour 5.000);
- 1 infirmier pour 13.989 (normes OMS = 5.000);
- 1 sage femme pour 21.440 femmes en âge de procréer (norme OMS 1 pour 5.000).

Plus de la moitié du personnel socio-sanitaire du pays travaillent à Bamako: 57% des médecins, 41% des infirmiers et 64% des sages-femmes.

1.12.3 Objectifs et Stratégies

Mettre à la disposition du Ministère de la Santé, de ses services déconcentrés et décentralisés, et de tous les acteurs du système de santé l'ensemble des informations et données nécessaires pour la conduite de leurs activités en tant réel. Avec les axes stratégiques suivants:

- Renforcement des structures technologiques supportant les services de Cybersanté;
- Télémédecine et Téléexpertise: expertise et fourniture des services et soins de qualité;
- Renforcement de capacité: formations initiale et continue, la gestion des connaissances, partage des bonnes pratiques;
- Statistiques sanitaires: flux et analyse de l'information sanitaire pour la prise de décision (situation sur le terrain, recherche, prévention, promotion, données sanitaires, données relatives aux infrastructures, aux équipements, aux ressources humaines, aux produits pharmaceutiques, aux vaccins, aux réactifs et autres consommables, données économiques et financières).

1.12.4 Activités Implementées

Les activités implémentées par l'ANTIM sont de trois catégories:

- les activités de cybersanté pour soutenir l'administration de santé, à travers des solutions spécifiques s'adaptant aux réalités locales;
- les activités de cybersanté pour soutenir les pratiques cliniques et les soins aux patients, à travers des outils adaptés aux pratiques cliniques locales et la délivrance de soins adaptés;
- les activités de cybersanté pour soutenir les activités de formation initiales et continues des professionnels de santé, avec des plateformes faciles à prendre en main et adapté aux conditions de faibles bandes passantes.

1.12.5 Technologies et Solutions Deployées

L'agence a déployé des solutions intégrées de cybersanté et d'autre sont en phase de test pour diffusion ultérieure.

Solutions pour l'administration de santé: faire de l'administration numérique une réalité quotidienne au sein du ministère de la santé au Mali avec:

- LE SITE WEB: il a été développé avec le CMS Joomla et intègre l'ensemble des textes législatifs du ministère de la santé et les textes généraux du gouvernement du Mali, est le lien électronique entre le ministère et les usagers. Il a permis à l'agence de gagner le prix du jury aux TIGA Awards 2009 de la commission économique des nations unies pour l'Afrique.

- IRED MAIL: Système sécurisé de gestion intégré de la messagerie électronique avec fonction d'annuaire informatique pour les professionnels de santé permettant aux utilisateurs des services web du ministère de la santé de s'identifier une seule fois.
- LA VISIOCONFERENCE AVEC UN PONT RMX 1000, DES STATIONS POLYCOM VSX 8000 ET SOLUTION LOGICIELLE POLYCOM PVX: Ce qui permet au ministère de la santé de tenir plusieurs réunions virtuelle par visioconférence depuis Février 2008. En 2009, le passage à échèle a été effectif avec les multiples participations du ministre aux rencontres internationales et audiences interministérielles.
- Solutions cliniques (télémédecine et informatique médicale): soutenir la santé des usagers par une utilisation judicieuse du numérique.
- REEVASAN: Réseau Electronique d'Evacuation Sanitaire qui est une plateforme en ligne basée sur le moteur de IPATH (Internet Pathology) pour la gestion des évacuations sanitaires en ligne du ministère de la santé. Cet outil a aussi été utilisé pour préparer plusieurs mission humanitaires qui sont venu faire des interventions gratuites au Mali.
- IKON: qui est une plateforme de téléradiologie, permettant aux radiologues spécialistes de Bamako de donner leur second avis sur des clichés pris dans les hôpitaux régionaux (Kayes, Sikasso, Ségou, Mopti, Tombouctou et Gao).
- PESINET: est la première plate-forme mSanté supporté par l'ANTIM. Il consiste à l'utilisation du téléphone mobile pour le suivi des enfants de 0 à 5 ans. A chaque visite des enfants, les agents de pesée saisissent les poids et les données annexes concernant la santé de l'enfant (vomissements, diarrhées,...) sur un téléphone portable. Ces données sont enregistrées sur la mémoire du portable, puis transmises, via le réseau GPRS, sur une base de données.
- FRONTLINESMS: est un logiciel installé sur un téléphone mobile qui permet l'envoi et la reception de message SMS. En utilisant ce logiciel, un ordinateur branché à un téléphone portable devient un centre de communication à faible coût. C'est la plateforme qui a été utilisé dans le projet de remonter de l'information sur les décès maternels et infantiles et les stocks de produits de santé de la reproduction avec le soutien du fond des nations unies pour les activités de population (FNUAP).
- GRH PROS SANTE 21 (GRH PS21): est un logiciel de gestion des ressources humaines en ligne customisé par l'ANTIM pour les pays francophones sur la base de la plateforme iHRIS de capacity project (USAID).
- MEDIBOARD: est un système web libre de gestion d'établissement de santé. Il se définit plus précisément comme un SIH (Système d'Information Hospitalier) c'est-à-dire un PGI (Progiciel de Gestion Intégré) adapté aux établissements de santé de toute taille, du simple cabinet de praticien au centre médical multi-sites.
- OPENCLINIC: Le système d'information médicale et hospitalière OpenClinic est une solution dédiée pour structures sanitaires hospitalières et de premier niveau. Il intègre, outre la gestion classique d'une structure sanitaire, des outils de reporting d'activité conçus spécialement pour l'approche district et répond donc à une double préoccupation: avoir de l'information sur les pathologies et les activités, ce qui permettra de mettre en œuvre plus facilement un système de gestion basée sur la performance, mais sera également précieux dans le cadre de la mise en œuvre future d'un système d'assurance maladie (ou des systèmes d'exemption de paiement).
- Solutions pour la formation: faire de la formation à distance une alternative attrayante pour les professionnels de la santé au Mali.
- DUDAL: est un outil de téléenseignement à faible bande passante. Développée par le réseau RAFT à partir du système e-cours de l'Université de Genève, elle est basée sur des technologies totalement logiciels libres. N'importe quel PC java compatible peut recevoir les cours. Chaque jeudi les professionnels de santé des structures sanitaires suivent des cours diffusés sur cette plateforme dans le cadre de la formation médicale continue et du renforcement de capacité.

- ELLUMINATE/BLACKBOARD™: La plateforme Elluminate est un outil de téléenseignement à faible bande passante développé par la société Elluminate INC du Canada. Elle est basée sur la technologie Java comme Moodle et est multi-environnement. Cette plateforme est utilisée au niveau de l'agence de télésanté pour soutenir le programme de formation initiale en maintenance biomédicale, en collaboration avec l'Institut National de Formation en Science de la Santé et le collège communautaire de Barstow au Canada.

1.12.6 Changements et résultats obtenus

Le premier résultat obtenu pour le Mali est l'institutionnalisation de la cybersanté. Depuis la création de l'agence les questions de cybersanté ont été prises en compte dans les formulations des politiques sanitaires et de leurs stratégies de mise en œuvre. Ainsi dans le document du programme decenal de développement socio-sanitaire prolongé 2011, le système entend très explicitement profiter des avantages qu'offrent les technologies de l'information et de la communication.

Par ailleurs les outils web mis en place permettent de rendre plus facilement accessible les informations sur le système ce qui a eu un fort impact sur la prise de décision à temps.

Il faut noter que grâce aux différents projets pilotes d'utilisations de la téléphonie mobile pour améliorer l'accès des mères et des enfants aux services de santé de qualité, l'ANTIM a été lauréat en 2011 des prix TIGA 2011 catégorie e-santé de la commission économique des Nations Unies pour l'Afrique.

1.12.7 Défis et facteurs de réussite

Malgré les résultats obtenus, il reste de nombreux défis à relever qui sont essentiellement de trois ordres:

- Les problèmes liés à l'interopérabilité des outils et solutions déployés, surtout quand il n'y a pas suffisamment de coordination entre les initiatives des différents acteurs,
- Les problèmes de connectivité, faiblesse des bandes passantes et cout élevés de l'accès à Internet,
- Les problèmes de changement de comportement, l'innovation fait souvent peur et son adoption fait face à des résistances,
- Enfin les problèmes de financement structuré des activités de cybersanté surtout à partir des budgets alloués à la santé.

Toutefois les facteurs de réussite sont l'existence de champions locaux qui poussent les projets de cybersanté, la disponibilité de ressources humaines qualifiées dans le domaine de la cybersanté, la volonté politique des autorités sanitaires d'adopter la cybersanté comme moyen de renforcer le système de santé.

1.12.8 Leçons apprises et prochaines étapes

Les projets pilotes et initiatives de la société civile sont nécessaires pour démarrer des activités de cybersanté. L'institutionnalisation est l'étape primordiale pour préparer le passage à l'échelle. Le passage à l'échelle a besoin de ressources financières conséquentes pour que l'utilisation de la cybersanté fasse la différence pour améliorer les systèmes de santé.

Enfin la perspective la plus importante pour le Mali est la suivante:

- Utiliser la cybersanté pour renforcer et améliorer le système d'information sanitaire.
- La détection des cas de maladies, le lancement des interventions pour prévenir la transmission ou réduire la morbidité et la mortalité, l'identification de nouveaux problèmes de santé (des maladies émergentes et/ou négligées), la mesure des tendances sanitaires et la recherche, nécessitent des données en général produites par la surveillance épidémiologique et le recueil périodique des données des systèmes de santé. Cette surveillance épidémiologique et ce recueil périodique des données des systèmes de santé constituent un mécanisme systématique de collecte, d'analyse, d'interprétation et de dissémination des informations sanitaires.

Pour le renforcement des systèmes d'informations sanitaires deux impératifs sont à respecter:

- Il convient de renforcer les systèmes d'information et de statistiques sanitaires dans leur ensemble plutôt que de s'intéresser à une maladie spécifique.
- Il faut tout particulièrement renforcer le rôle directeur des pays dans la production et l'utilisation de l'information sanitaire.
- Il s'agit de produire des informations pertinentes dont les parties prenantes du système de santé peuvent se servir pour prendre des décisions transparentes qui reposent sur des bases factuelles concernant les interventions sanitaires.

La cybersanté peut aider les pays à accroître considérablement leurs moyens de stockage de données et à réduire les délais précédemment nécessaires pour leur traitement. Les technologies de l'information et de la communication peuvent donc améliorer de manière spectaculaire la disponibilité, la qualité, la diffusion et l'utilisation des données liées à la santé. Si les TIC permettent d'accroître le nombre de données recueillies et d'en améliorer la qualité, elles permettent aussi de réduire les délais et d'améliorer l'analyse et l'utilisation de l'information. Une infrastructure de communication est donc nécessaire pour exploiter pleinement les informations qui sont disponibles.

Au niveau central et local, les responsables de la santé doivent donc avoir accès à une infrastructure de l'information offrant notamment des ordinateurs, le courrier électronique et un accès Internet. Bien que l'accès à Internet soit de plus en plus important, les systèmes téléphoniques de base (fixes ou mobiles) restent toujours extrêmement utiles.

Un renforcement cohérent des capacités portant sur les moyens électroniques et les ressources humaines dans l'ensemble du système de santé constitue une approche efficace.

Le minimum requis est une base de données sur les établissements de santé et les services essentiels fournis. Il faut ensuite cartographier les établissements, les ressources humaines, les budgets et les dépenses, les produits de base et les services essentiels aux niveaux national et du district. Un équipement GPS (Global Positioning System) et un système d'information géographique (SIG) sont en général utilisés pour déterminer la position géographique des sites de prestation de services et les frontières administratives, et pour les localiser sur une carte informatisée. En effet, la cartographie des ressources disponibles, des interventions spécifiques ainsi que des pathologies peut fournir des données importantes du point de vue de l'équité, et encourager les efforts visant à ce que les interventions nécessaires soient menées dans les zones périphériques et ne restent pas concentrées dans les centres urbains.

Lorsque des infrastructures de communication électronique sont disponibles, les données peuvent être saisies au niveau décentralisé pour pouvoir être immédiatement notifiées à tous les niveaux.

Enfin, le but du stockage, de l'assurance qualité, et du traitement et de la compilation des données est de présenter des informations utiles de manière crédible, cohérente et pertinente. Les données doivent être intuitives et évidentes pour les acteurs du système d'information sanitaire. Pour que l'information soit intelligible, il faut qu'elle soit lisible. Les contenus du système de gestion des données doivent être clairement libellés. Les acteurs de ce système souhaiteraient également pouvoir séparer et combiner les données du système de différentes façons. Les outils qu'ils utilisent pour accéder au système doivent être simples et faciles à utiliser, et doivent permettre de répondre aux demandes qui ont été formulées dans des délais très courts.

Une information n'a de valeur que lorsqu'elle est intégrée à d'autres informations et qu'elle est évaluée à la lumière des problèmes auxquels le système de santé est confronté. A ce stade, une information devient une base factuelle qui peut être utilisée par les décideurs. Ces bases factuelles, une fois regroupées, sont encore plus utiles lorsqu'elles sont mises en forme aux fins de présentation, de communication et de diffusion aux décideurs, de manière à changer leur perception des questions et des besoins de santé. On entre alors dans le processus de transformation des bases factuelles en connaissances qui, une fois appliqué, peut se traduire par des décisions ayant un impact direct sur la santé et sur l'équité en santé. Le

système d'information sanitaire permet ensuite de mesurer cet impact réel sur la santé, ainsi que l'évolution des indicateurs de santé.

La prise de décision est itérative et fondée sur des données factuelles, tout en s'appuyant sur un système d'information sanitaire complet à l'échelle d'un pays.

Un système d'information sanitaire n'a pas seulement pour but de produire des données de qualité, dans l'espoir qu'elles soient ensuite utilisées; il doit aussi les convertir en données crédibles et convaincantes qui éclairent les décideurs au niveau local. Des données de qualité stockées dans des systèmes d'archivage bien structurés n'ont guère d'intérêt si les utilisateurs ne peuvent y accéder pour produire des informations utiles à la prise de décision.

Beaucoup d'innovations se sont récemment produites dans le domaine des TIC et ont permis de présenter des informations et des bases factuelles complexes dans des formats qui attirent l'attention des décideurs et de communiquer efficacement les messages contenus dans l'information. Certaines méthodes s'appuient sur un accès via Internet ou un ordinateur à des données provenant de systèmes d'archivage ou d'observatoires présentées sous une forme interactive. De nouveaux outils d'analyse informatisés permettent d'établir des rapports normalisés riches en présentations graphiques (et même cartographiques) de l'information. Les formulaires de notification, les descriptifs et les résumés normalisés sont également très efficaces. Ces formats doivent orienter les décideurs en leur fournissant des interprétations fondées sur les conséquences probables des décisions et des scénarios de rechange qu'ils envisagent. L'information peut également être diffusée par l'intermédiaire d'ateliers, de revues médicales, de réunions entre homologues et des médias.

La mise en place d'une architecture de l'information en tant que ressource commune au niveau national et du district est une étape indispensable pour améliorer les pratiques en matière d'information et pour pouvoir effectuer les analyses de qualité nécessaires. C'est à partir de ce niveau d'analyse que les résultats sont utilisés pour l'élaboration des politiques et la planification stratégique. Ces analyses, interprétations et activités de sensibilisation ne sont pas spontanées. Elles requièrent en effet la mise en forme, la communication et la diffusion selon une présentation et dans un langage accessibles aux décideurs de haut niveau. Un aspect qui est souvent négligé dans la plupart des systèmes d'information sanitaire.

L'une des fonctions les plus importantes du système d'information sanitaire est de relier la production à l'utilisation des données. Ceux qui sont chargés de collecter les données doivent aussi tirer parti de leur utilisation. Les utilisateurs comprennent les prestataires de soins, les responsables de la gestion et de la planification des programmes. De manière plus générale, les utilisateurs comprennent ceux qui financent les programmes de soins dans les pays (ministères de la santé et des finances) et à l'extérieur (donateurs, banques de développement et organismes d'appui technique). Les utilisateurs des données sanitaires ne se limitent pas aux professionnels des soins de santé, aux gestionnaires et aux statisticiens. La prise de décision concernant les priorités de santé d'un pays implique nécessairement les populations, la société civile et les décideurs.

1.13 Niger: E-health Status and Prospects in Niger

1.13.1 Current Status

¹⁴The implementation of e-health in a country often calls for the establishment of either an e-health policy or an ICT development policy with an e-health component. In Niger, there is something of a blank

¹⁴ Contribution: Yaya Arouna, Telecom Engineer, Multisectoral Regulatory Authority (ARM), Niger. See document [SG02-C-017](#)

slate, insofar as, apart from the NICI plan¹⁵, there is nothing to suggest that there are any policies, standards or legal or institutional arrangements in this area.

There are however some activities that may be considered as falling within the domain of e-health, namely communications using VSAT to connect regional structures to the districts under a project known as RAFT (Telemedicine Network in French-speaking Africa).

The activities focus primarily on remote radiology between national, regional and district hospitals, remote consultation and remote expertise using the RAFT Ipath tool, as well as distance learning with weekly RAFT e-courses every Thursday at 0900 hours UTC.¹⁶

There has also been some institutionalization of e-health with the establishment of an E-health Development Support Unit under the responsibility of the office of the Minister for Public Health.

Even though these are only very basic steps, it is encouraging to note for the future that Niger is getting involved in a regional movement towards establishing a genuine e-health framework in order to address and overcome some of the inherent problems within the health system, with the aim of achieving the MDGs. What does this movement entail?

1.13.2 E-health prospects

Rather than confining themselves to a national perspective, the member countries of the Economic Community of West African States (ECOWAS), including Niger, have shown a clear desire to move forward together as a region.

With this in mind, they have envisaged an e-health strategic plan for this regional African block. The plan sets out the vision and strategic orientations, along with implementation projects. It is these aspects which we will try to develop for the future of e-health in Niger.

1.13.3 Vision

The ECOWAS countries are committed to implementing e-health through an agreed vision: “*E-health: reducing distances and improving access for rural populations in particular to quality health services in an integrated space*”. A strategic plan¹⁷ with orientations has been established for the period 2011–2013.

1.13.4 Strategic orientations

Several strategic directions have been defined to ensure the success of the plan, whose primary aim is to significantly improve the quality of the management of health and treatment systems for the populations of the region, by developing and supporting integrated health policies and reform initiatives.

These strategic directions are as follows:

- Strengthening countries’ systems using e-health as a means of improving coordination, harmonizing human resources policies and management in the health domain within the regional Community space.
- Use e-health to strengthen and improve the health information system.
- Integrate e-health in the overall service portfolio of health structures within the Community space.

¹⁵ Plan for the implementation of a governmental intranet. www.pnud.ne/RaportplanNICI.pdf

¹⁶ Strategic plan for the development of e-health in ECOWAS – 2011 to 2013.

¹⁷ www.sante.gov.ml/docs/PSDC_OOAS_1er_fevrier2011.pdf

- Ensure the availability of a reliable and sustainable subregional infrastructure capable of supporting e-health applications.
- Use e-health as a means of initial and continuous training, knowledge management, promotion and dissemination of good practices within the Community space.
- Use e-health to support research activities.
- Use e-health to promote traditional medicine.
- Ensure that e-health is accepted and adopted by all stakeholders, through successful change management.

It is these defined directions that must guide projects to be implemented. We shall confine ourselves here to highlighting a few projects which appear to be the most important.

1.13.5 E-health Implementation projects

The projects identified include:

- **Project for the elaboration of a national e-health plan**

Under this project, each member state, including Niger, is to draw up a national e-health plan (NEHP).

- **Project for a national health data repository (NHDR)**

Countries' health systems are confronted by serious problems of management, storage and archiving of data collected by the various health information subsystems. This observation is corroborated by recurrent delays in the publication and dissemination of collections of health information statistics.

Figure 9: Project for a national health data repository (NHDR)

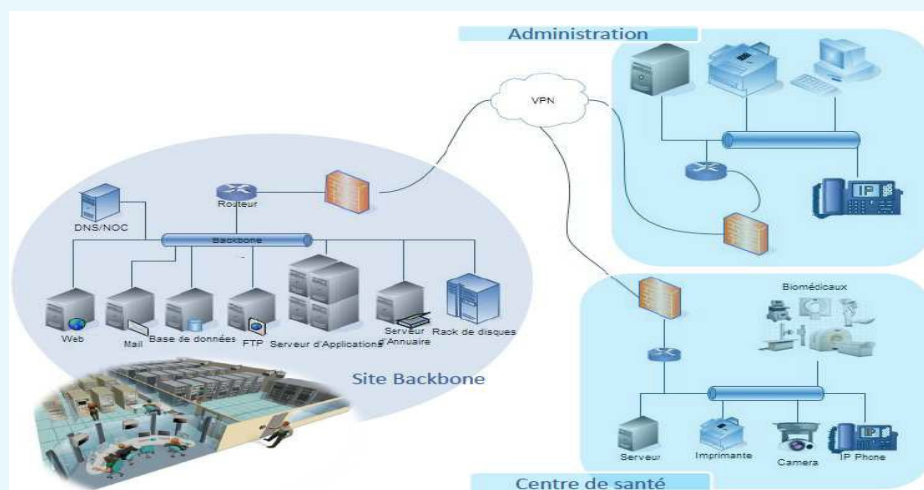

The NHDR is a comprehensive and definitive solution to the problems of management, dissemination, use, storage and archiving of health information.

NHDR is a reliable medium supporting various applications: telemedicine, medical information (Clinical Information System, Medicine Information System, Radiology and Laboratory Information System, etc.), administrative management, health information system and planning.

Figure 10: Project for a mobile health fleet

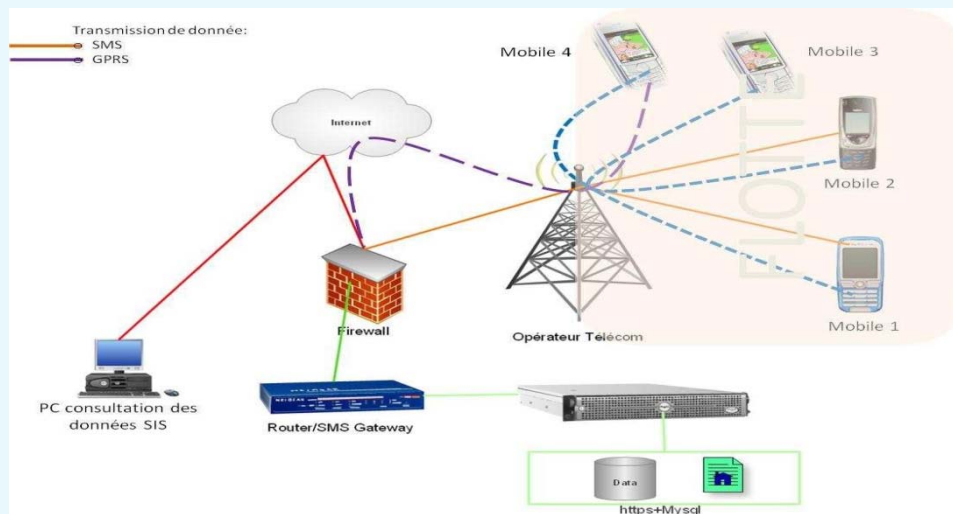

The objective of this project, in the mind of its developers, would be to allow real-time and secure transmission of health information using mobile telephony and to automate the process of analysing, processing and disseminating health information.

To this end, technological solutions are considered, as described in brief below.

The idea is to network mobile telephone terminals supporting the transmission of data and sms. The fleet also supports voice. An infrastructure diagram for such a mobile fleet is shown below.

Terminals are loaded with forms to be completed with data in the field, which once captured will be transmitted via GSM terminals or smartphones to specially-equipped servers in the NHDR.

The data transmitted are automatically processed and can be exploited by any authorized health professional. In addition to data transmission for the health information system, health professionals with terminals in the fleet can communicate with each other by voice and sms. The terminals in the fleet can only communicate with each other.

Figure 11: Terminals in the fleet



- Physical infrastructure

The physical infrastructure consists of mobile terminals and the infrastructure of the suitably equipped NHDR. The mobile terminals are GSM phones, smartphones and netbooks.

- Software solution

FrontlineSMS is a freeware allowing the sending and reception of sms messages. Using this software, a computer connected to a mobile phone (see Figure 11) becomes a low-cost communication centre. Only the operator's sms price is charged.

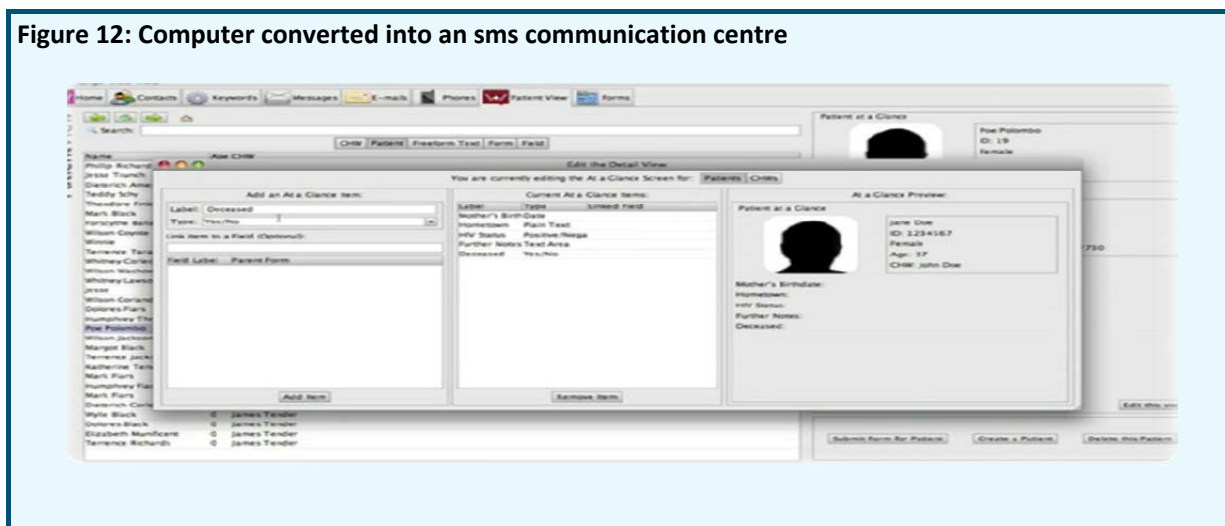
Figure 12: Computer converted into an sms communication centre

Use of the Patient View module creates a new user interface in FrontlineSMS. It allows all relevant data concerning a patient to be displayed. Health workers will also be in a position to sort, update and add new entries concerning the patient via the central computer and the mobile phone. This yields a mini computerized medical file, as shown in Figure 12.

In addition to these projects, it should be mentioned that, in cooperation with India, a project for a pan-African e-network with an e-health component is under way, which provides for the installation of a VSAT in the national hospital (NH) at Lambordé (university hospital centre).

1.13.6 Conclusion

It clearly emerges that, in terms of e-health, Niger is really only at the planning stage. Today, based on the current development of the telecommunication/ICT infrastructure, Niger intends to speed up these projects. To this end, it will be requesting ITU/BDT support through the relevant programmes, in particular Programme 5, whose purpose is to help least developed countries (LDCs) members of ITU with targeted assistance for their economic and social development.

1.14 Pakistan: e-Health in Pakistan

1.14.1 Telehealth initiatives in Pakistan

- ¹⁸Telemedicine/e-health Training Centre was established at Holy Family Hospital, Rawalpindi to train medical staff of the region in telemedicine applications. This was a joint collaboration between ministries of science and technology of Pakistan and USA. The project was a six months' pilot in which a model training centre was established in Holy Family Hospital and connected to a remote telemedicine centre in a rural area. This has acted as a training ground for telemedicine training of doctors and nurses. In the initial phase 45 doctors and nurses from Rawalpindi region were trained in telemedicine applications.
- Ministry of Information Technology: Health Net Project - Ministry of Information Technology launched its Health Net Project in November 2007 and this initiative is in the implementation phase. This project is being funded by Federal Ministry of Information Technology for three years with a commitment from Provincial Governments of Punjab and Sind to continue and bear the cost of recurring expenditure. MoIT-Health NET is a telemedicine project meant to assist the

¹⁸ Asif Zafar Malik, Professor of Surgery, Holy Family Hospital, Rawalpindi, Pakistan. See document [RGQ14.3.2-INF-0003](#)

government in transforming delivery of healthcare services and making them available at the door-steps of the common man, through the use of Information and Communication Technology.

- The project demonstrated the use of technology as a solution for overcoming the lack of quality healthcare infrastructure in rural/remote areas of Pakistan. The objective is being achieved through setting up telemedicine hubs in tertiary care centres connected via PAKSAT-1 to 4 telemedicine centres in rural hospitals, by utilizing and complementing available national resources and infrastructure. A total of fifteen satellite based telemedicine centres have been established all over the Pakistan. Tertiary care centre at Holy Family Hospital, Rawalpindi and Mayo Hospital, Lahore in Punjab Province and one hub centre JPMC, Karachi in Sind Province have been identified as hubs for providing telemedicine consultations to their remote catchment areas. Each of these hubs has been linked with four remote sites through satellite connectivity. All these centres are equipped with telemedicine peripherals to facilitate the teleconsultations in radiology, Surgery, Medicine, Cardiology, Otolaryngology, Dermatology, psychiatry and orthopaedics. Regular consultations are being provided to remote patients through this network. The Government of Pakistan has taken a bold initiative to utilize ICT for transforming delivery of public services by making such services more effective, inclusive, efficient and available at the door steps of common men. Setting up rural telemedicine centres has enabled rural population to seek consultation, advice and treatment from specialist doctors in urban centre hospitals, without having to travel hundreds of kilometres and spending their meagre financial resources on related transportation and accommodation costs. The project also provides training in advanced treatments and diagnostics to doctors working in rural/remote hospitals, through interaction with specialist doctors in urban hospitals. In the last three years thousands of patients in these remote districts have benefited from the Telemedicine rural support program.

1.14.2 e-Health initiatives: The Aga Khan University Karachi (AKU)

- Telehealth/telemedicine: Tele-radiology Project between AKU and French Medical Institute for Children (FMIC) Kabul, Telehealth Project in Northern Areas of Pakistan (Districts Gilgit, Gizar and Hunza) extending up to the Pakistan China Border.
- Health Informatics: Developed 47 integrated clinical information systems, PACS are implemented according to global standard. AKU is also conducting a Cost Benefit Analysis of available Hospital Information management system. The University is working with Ministry of Health (HMIS-cell) in designing and implementing Real time Bio Surveillance system for the country.
- E-Learning
- Geographic Information Systems (GIS) GIS: Environmental Health, GPS use in Tobacco Control study to collect point data

1.14.3 Ministry of Science and Technology: Multitasking of Telemedicine/E-Health Training Centre

- Joint collaboration between USA and Pakistan in field of science and technology opened a new era of telemedicine training. This has led to the establishment of Telemedicine/E-health training Centre at HFH to train doctors and nurses in the field of telemedicine.
- Telemedicine/E-Health training centre is a designated facility for e-health training and is jointly working with Virginia Commonwealth University, USA. Four remote hospitals are attached to the centre through satellite connectivity. These hospitals are DHQ hospitals in Attock, Khushab, Gujrat and THQ hospital, Pindi Gheb. This centre has trained more than 100 doctors and nurses in Telemedicine applications so far. In the initial phase medical staff from Rawalpindi/Islamabad region was trained and now in the second phase 60 more people have been trained. These trainees were from various institutions all over Pakistan and after completing their training are actively using telemedicine to strengthen healthcare delivery in their own institutions.

- Telemedicine/E-Health Training centre also established tele-rehabilitation centre in Muzaffarabad, Kashmir for paraplegics of recent earthquake. During the earthquake of 2005, 194 paraplegics (because of spinal cord injuries) were brought to Rawalpindi Medical College and allied hospitals. These patients received their initial treatment at these hospitals and were discharged after that. The hub of this Tele-rehabilitation network is at Holy Family Hospital. The remote centre is in Muzaffarabad hospital. Telemedicine/E-health training centre will train patients and their attendants in utilization of Tele-rehabilitation services. Development of pressure ulcers, which are a known complication of paraplegics, will be monitored. Physiotherapy measures will be taught to patients and progress will be evaluated. Moreover satisfaction of patients and their attendants regarding the use of this technology will be evaluated.
- US State Department's Pakistan Telemedicine Project – is providing expanded medical care – pre-operative planning and follow-up; cardiac assessment; ophthalmology, dermatology, radiology, infectious disease, and perinatal evaluations; and medical triage for traumas and acute illnesses. Another important aspect of the project is building capacity for healthcare services via virtual clinical grand rounds for medical education. The partnership includes Wateen Telecom, Motorola Inc., Medweb Inc., USAID, the U.S. Department of Defense Telemedicine and Advanced Technology Research Center, the Pakistani Government, and Telemedicine & E-Health Training Center, Holy Family Hospital in Rawalpindi and District Headquarters Hospital in Attock.
- Emergency Telemedicine Response in Pakistan.

1.14.4 Role of International Telecommunication Union

- The 2005 Earthquake of Pakistan left widespread destruction, killing at least 80,000 people, severely injuring another 70,000 and leaving 2.8 million people without shelter. Telemedicine center developed mobile telemedicine units with collaboration of International telecommunication union (ITU) and INTEL. International Telecommunication Union provided on loan 15 Inmar-Sat Satellite modems to be deployed in areas where there was no communication available. Telemedicine centers were established in NWFP and AJK, most affected areas of Pakistan. These centers were established in existing relief hospitals. The Medical staff got consultation about the earthquake victims from consultants at the hub.
- On 10th December 2007, the International Telecommunication Union (ITU), and the Telemedicine & e-Health Training Center, Holy Family Hospital of Rawalpindi in Pakistan signed a Memorandum of Understanding (MoU) for Cooperation in Disaster Preparedness and Response through Telemedicine and e-Health. The Parties have already successfully collaborated in the area of telemedicine and emergency telecommunications following the massive earthquake that struck the Pakistan-India border area in October 2005, during which a total of 25 medical doctors were trained in the use of 55 satellite terminals in delivering telemedicine services and applications. The Parties intend to implement joint projects/activities, share information on e-Health, and cooperate on enhancing access to information related to emergency telecommunications and telemedicine for disaster preparedness and disaster relief.
- Emergency Response Telemedicine Vehicle: 2009 – Holy family hospital (HFH) was one of the hospitals actively involved to provide health care to Internally Displaced Persons (IDPs) of Swat and Mardan districts. Apart from mobilizing teams to provide on-site medical care, telemedicine was added to strengthen these services. Initially, teams comprising of doctors of all major specialties like Surgery, Medicine, Ob/Gyne, ENT/EYE and Paramedics were in Mardan. It was then possible to cover all other specialties and at the same time have opinions from senior medical staff based at Holy Family Hospital. This was possible by Mobile Telemedicine vehicle made operational under supervision of Telemedicine/E-Health Training Center at Holy Family Hospital. Teams from HFH including doctors and paramedics were sent to refugee camps to address their medical problems. Specialist support to these teams was provided through Teleconsultations utilizing a Mobile Telemedicine vehicle. This was indigenous customization of an ordinary vehicle. The capsule of the vehicle was designed and developed locally. The satellite dish for communication was mounted on

the top. The vehicle was further equipped with Video Conferencing equipment and telemedicine tools like general examination camera, Otolaryngoscope, ECG, related medical and IT equipment. Satellite connectivity was provided by Pak Datacom. The medical staff at refugee camps, after initial evaluation of the patients, used to discuss it with specialists at HFH for further evaluation and management.

1.14.5 Floods in Pakistan in 2010

- Multitasking of Existing Rural Telemedicine network
 - Rajanpur and D.G. Khan are in the middle of the worst affected areas of lower Punjab. Hospitals in these cities are part of the Telemedicine network of rural support program Pakistan. Fortunately these facilities were not damaged during the floods. Telemedicine and e-Health training centre streamlined the Emergency Telemedicine response in the wake of floods utilizing the existing satellite network provided by the Ministry of Information and Technology. Mayo Hospital Lahore and Holy Family Hospital Hubs have been running virtual clinics and providing teleconsultations to patients in attending remote sites.
 - The methodology is simple, utilizing video link. Specialists from Departments of Medicine, Paediatrics, Dermatology and other specialities are available daily according to schedule provided to remote sites. The IT resource person and paramedics at the remote sites are facilitating these consultations while staff at the local hospital is busy providing care at camp sites. Since the start of these services more than 3593 patients have received treatment. Predominant amongst these are skin conditions and waterborne diseases like Gastroenteritis as predicted and expected. This data is extremely useful for Health departments to plan relief operations by mobile health teams.
- Mobile Telemedicine centres in Gilget, Baltistan, Rural Sindh and Punjab:
 - International Telecommunication Union was once again in the forefront to assist Pakistan during the floods. It airlifted equipment for Telecommunication like data terminals, Inmarsat satellite modems and Satellite phones. Federal Ministry of Information Technology coordinated these efforts by releasing the equipment, and getting relevant licences from PTA for using this equipment. Telemedicine and e-Health training centre was entrusted the task of training and coordinating these efforts in setting up mobile telemedicine centers. On-site training was arranged for staff of AKU, HDF, SEECs (NUST) and Attock district staff. These centres are operating all over the country, and ITU has very kindly extended the connectivity period for a further three months.
- International e-Health Conferences in Pakistan:
 - First International e-Health Conference – The e-Health Association of Pakistan organized its first International e-Health Conference at the Aga Khan University, Karachi on 23-24 January 2010. The conference was telecasted live at the National University of Science and Technology, Islamabad. The conference attracted stakeholders from the Ministries of Health and Information Technology, National and International development organizations, health care institutions, academic institutions in health, engineering and telecommunication, and students from a variety of disciplines. Several keynote addresses, scientific sessions, workshops and panel discussions were arranged to provide opportunity to the experts, researchers, and participants to share their views.
 - Second International e-Health Conference – The e-Health Association of Pakistan organized its Second International e-Health Conference at the International Islamic University, Islamabad, Pakistan on 22-23 January 2011. The conference was telecasted live at the Aga Khan University, Karachi. This Conference was a unique feature in Pakistan, allowing healthcare providers, allied health professionals, IT experts, telecommunication companies, managers, and educational institutions in health, biomedical and IT fields to reflect on ways to collaborate for improving health of the population.

- e-HAP Workshops – Considering the growing demand of e-Health, a two-day Knowledge Sharing Workshop “e-Health Knowledge Sharing workshop”, was organized by e-Health Association of Pakistan (e-HAP) in collaboration with LIRNEasia, Sri Lanka on 29-30 September 2010 at Islamabad Club, Islamabad, Pakistan. The purpose of the workshop was to share and compare the findings of e-Health initiatives in Pakistan and other South East Asian countries. The workshop was attended by representatives from the Ministries of Health and IT, public and private healthcare institutions, NGOs and academic institutions.

1.14.6 Research and Development in e-Health Pakistan

- NUST University Islamabad: Healthcare Applications Interoperability through Implementation of HL7 Web Service Basic Profile.
- FAST University Islamabad: Next Generation Intelligent Networks Research Centre Remote Patient Monitoring System with Focus on Antenatal Care.
- LUMS, LAHORE: A Low Cost Ultrasound Training Simulator: Investigating Wavelet based Video Coding and Video Conference Applications.
- Aga Khan University: PANACeA project (PAN Asian Collaborative for Evidence-based e-Health Adoption and Application):
 - Research in e-Health in 12 Asian countries. Use of Mobile Phone in Bridging the Gap for Referral of Pregnant Women.
 - Mainstreaming e-Health initiatives in primary care: an evidence-based approach Online TB Diagnostic Committees for Clinically Suspect Sputum Negative Patients in the TB-DOTS Program.
- Regional and International Cooperation: Telemedicine/E-health.

Pakistan is playing a key role in establishing collaborations internationally and in the SAARC region, to promote e-health by partnering with International organizations like: APT, SAARC, WHO, ATA and Rockefeller Foundation.

1.15 Tanzania: Status of e-Health in the United Republic of Tanzania

1.15.1 National Optical Fiber Backbone: For Telemedicine Services

¹⁹The e-governance initiative of the Government of Tanzania is to establish the National Fibre Optic Backbone to provide essential connectivity for e-services. The network now covers all regional centres and will be extended to all districts beginning the second half of year 2012. We are planning to take advantage of this e-governance initiative to establish the connectivity needed for telemedicine.

In June 2011, the India-Tanzania Centre of Excellency in ICT provided, among other things, telemedicine related facilities (bed + mattress; ECG Machine; DVD Player; X-ray Scanner; Microscope with Digital Camera; TV Screen; Conferencing camera and telemedicine software) which have been installed in 10 hospitals.

In mid 2011, the Hon. Prof. Makame Mbarawa, Minister of Communication, Science and Technology called a stakeholders meeting to discuss on how to harmonize the telemedicine initiatives in Tanzania. During that meeting, the National e-Health Committee was formed including members from different organs as outlined below. It was further agreed that, to start with as pilot project, two rural hospitals and

¹⁹ Contribution: Deogratius A. Moyo, Tanzania Communications Regulatory Authority (TCRA), Tanzania (United Republic of). See document [SG02-C-0228](#)

three referral hospitals will be connected this year. Currently, all necessary preparations for establishing this pilot project are in place. The project is planned to offer the following categories of services:

- Consultations with Specialists: patient/doctor consultation through mobile phones or internet;
- Videoconferencing: Clinical Case presentations, Clinical Pathological Conferences, Tumor Boards, State of the Art Presentations by specialists;
- Continuing Medical Education: Clinical Materials prepared by Specialists, Service Policies & Procedures for quality improvement, and Pre-service training of various health professionals.

1.15.2 Challenges

The connectivity and operation of this project, however, faces some challenges as follows:

- High cost in connectivity from the National Telecommunications company.
- Lack of fund for training of doctors and nurses.
- Lack of sustainability assurance.
- No framework for telemedicine and related policies, regulations and procedures.
- Telephone Communications among Health Workers

Communication among health workers is essential for consultations, referrals and facilitating the telemedicine services. In 2011, the National Referral Hospital in Dar es Salaam (Muhimbili) initiated a plan to establish a closed user group among health facilities, staff and doctors within hospital through mobile network services from national telecom company (Tanzania Telecommunications Company Limited-TTCL). In this initiative, all doctors, wards, laboratories and radiology sections were included in a closed user group with freely unlimited calls among them. Extension of the closed user group countrywide is constrained by limited coverage of TTCL mobile services.

While TTCL is exploring the possibility of integrating their landline services for countrywide coverage, the Ministry of Health and Social Welfare (MOHSW) has agreed to join efforts with Switchboard Company of the USA and one of the largest mobile company in Tanzania (Vodacom Tanzania Limited) to establish a mobile closed user group to include all key health workers in all Vodacom covered areas in Tanzania. There will be no direct financial implications to MOHSW and all voice calls and text messages within the group will be free. An MOU is being finalised and network establishment is planned to start this year.

1.15.3 Recommendations

Following the challenges faced by the Government of Tanzania in implementing e-health services, we appeal to ITU and other players for support in knowledge sharing, fund, and training.

1.16 Turkey

1.16.1 Case 1: TEPE – Turk Telekom Technological Cooperation: Integrated Healthcare Management Information System

²⁰Integrated Healthcare Management Information System (IHMIS) is realized by TEPE Technologies and Turk Telekom Cooperation. IHMIS is an integrated software system that permits to manage and store all data of “A Class” Healthcare Providers. In this cooperation, the software system is provided by the TEPE Technologies and Turk Telekom provides 2 Mbit internet connection and personal data security.

²⁰ Contribution: Arıkan Dalkılıç, Turk Telekom Group, Turkey. See document [SG02-INF-0058](#)

IHMS can be a good example of the cooperation between telecommunication companies and software information companies in the health sector.

Introduction

Integrated Healthcare Management Information System (IHMS) is designed by TEPE Technological Services. IHMS is an integrated software system that permits to manage and store all data of “A Class” Healthcare Providers. The main purpose of IHMS is to serve the right information at the right time to the right person continuously and directly, all the system components are designed and implemented for asynchronous (Store-forward) operation as well as synchronous for the highest resilience.

Since Integrated Healthcare Management Information System (IHMS) is a holistic system primarily developed for forthcoming healthcare providers. IHMS is a total system comprehending:

- End-to-end collaboration of primary, secondary and academic healthcare units upon standardized clinical and administrative Hospital Information System (HIS) workflows and business processes.
- Utilization of centralized framework using common Master Plan Index and Electronic Health Records databases.
- Empowerment of medical diagnosis and treatment systems with state-of-art Medical Ontologies, Classification and Coding Corpus.
- Co-execution with a centralized and Coding Corpus.
- Elevated point-of-interest decision support and in-depth OLAP analyses designed for different command levels.
- Centralized system administration and control functions warranting rapid, remote and scalable installation.

Figure 13: Integrated Healthcare Management Information System (IHMS)

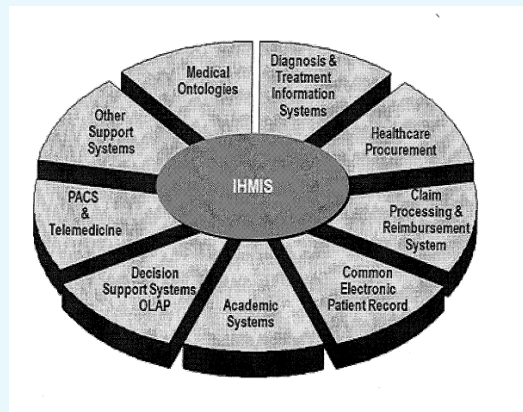

IHMS infrastructure designed upon core technological components listed below:

- Medical Data Dictionary: Enterprise Medical Data Dictionary, a specific database, has an information model that will be the guide for forming an electronic patient record. Medical Data Dictionary will be an information system that will consist of a controlled medical vocabulary including third party coding systems such as ICD-10, CPT and SNOMED, a semantic tool that makes possible to establish semantic relations between medical concepts and a database.
- Clinical Data Repository: In order to create life-time electronic patient record, Enterprise Clinical Data Repository(CDR) will be developed which will support problem-oriented medical record

structure and will become a central database that the physicians could reach at the point care, analyze data, input data. CDR will be developed as complying with ASTM and HL7 standards.

- **Master Patient Index System:** Enterprise Master Patient Index (MPR) will be developed in order to describe patient patients' (?) apply to one of the institution' rapidly and correctly. Enterprise MPR will integrate about patients' demographic and their applications will be obtained centrally and summarized.
- **Clinical Workstation Application Software:** An easy to learn and user friendly interface will be developed that allows users to reach previous records (if any) of inpatients and outpatients. The user interface having open system characteristics will be developed via utilizing CCOW (Clinical Context Object Workgroup) standards and components as DCOM, COM+, etc., XML technologies.
- **Enterprise Registration System(ERS):** will provide unique solution for executing all record processes of all related departments according to the Enterprise workflow, ERS will be developed as complying with ASTM and HL7 RADT(registration, administration, discharge, transfer) standards and Enterprise MPR will be a part of ERS applications. ERS will also include an appointment system that allows programming institutions, medical sources and patients' time.
- **Case-Mix Classification Systems:** Standard data sets will be created for inpatient and outpatient in order to be able to evaluate healthcare quality and costs and deliver internationally comparable information.
- **Data Entry Tools:** One of the main principles in creating electronic patient record is to guarantee entering structured and coded data of the electronic patient records. By using enterprise medical data dictionary; will be developed natural language processing tools for structured and coded data entry from free medical texts in electronic environment and dynamic data entry tools for directly structured and coded data entry.
- **Enterprise Object Oriented Workflow Platform:** will be developed in order to make it possible to set relations possible to set relations between Enterprise EPRS and enterprise resources such as healthcare personnel, medical units and medical equipment, work according to the enterprise workflow and exchange data institution's other information systems. Enterprise Object Oriented Workflow Platform; will include a flexible and adaptable modelling tool that will make possible to model enterprise sources and workflows and a messaging interface with HL7 standard to provide data exchange between other health information systems such as hospital information system(HIS) of Enterprise EPRS in institution, laboratory information system(RIS), radiology information system(LIS).

Successful Case Analysis: Turkish Armed Forces and IHMIS

Turkish Armed Forces (TAF) has used the Integrated Healthcare Management Information System (IHMIS) for more than 10 years. TAF IHMIS covers whole country, 3 academic level and 44 secondary level hospitals, and served over 2,5 million people. TAF IHMIS is the second largest national healthcare system of Turkey, after Ministry of Health hospitals.

TAF IHMIS holds and executes total capabilities of a healthcare system including essential medical processes, military healthcare logistics and public reimbursement regime. TAF IHMIS is a globally unique project not only due to its extended capabilities but also its technological pillars. TAF IHMIS, is almost one of the successful projects throughout the world employing longitudinal electronic health records (EHR). TAF IHMIS ensures lifetime health records of personnel accessible under patient privacy and safety legislation. TAF IHMIS executes an end-to-end healthcare logistics workflow which is traceable from procurement till terminal point-of-use. In financial terms TAF IHMIS manages a healthcare service approximately two billion dollars per year. TAF IHMIS project is accepted as a backbone system for TAF military requirements, namely progressing towards mission area mobility and interoperability.

TEPE Technological Services, as a total solution provider supports its clientele with an implementation methodology. An illustrated development and deployment methodology of TEPE is given below.

The methodology encompasses hand-to-hand execution of project engineering and product line engineering. Since IHMIS is an enterprise management platform is stretch, primary step of the implementation starts with domain analysis. Domain analysis step ensures proper and in-depth analysis of client requirements. The analysis also covers workflow and user interface requirements. The logical design of the tailored solution accordance with the client requirements are supported by domain expertise and whole perspective of business requirements. The outcome of domain analysis is converted into initial system implementation. The implementation steps were shown in Figure 14.

Figure 14 Deployment methodology of TEPE

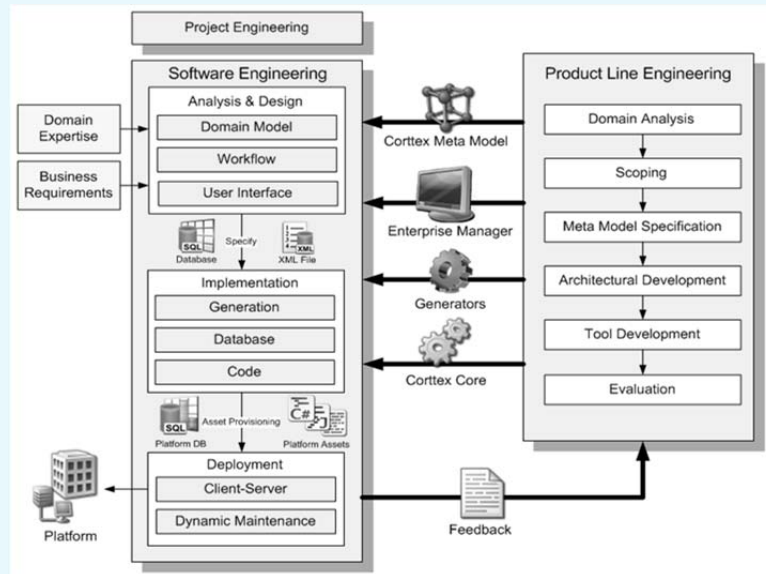

The initial implementation is the transition phase before full scale implementation and covers all preliminary setup of databases, preset user interfaces and roles/privileges that is adapted to user environment. Over the initial implementation, the software bundle customized with respect to client workflows, additional development were accomplished and finally the final system design is made to ready for integration tests. Integration tests were conducted with simulated yet full scale data sets plus, integration of medical devices and other third party solutions. After the successful integration tests, the system deployed to client production environment and data migration tasks finished. With the ultimate performance tuning, the system is accounted as available to go-live phase.

About Tepe Technologies:

TEPE is an innovator and leading company that produces and invests real national technologies, has a place in international information technology market, produces and shares information and sets standards, is perceived as a brand, is being consulted and its solutions are taken as a reference in the field of health informatics and workflow systems.

TEPE Technological Services designs and delivers applications on internationally acknowledged health informatics standards since 1993. Company:

- Produces information technology solution to provide the information management requirements of institutions in all levels and make them work in more efficient, qualified and productive manner.
- Develops information systems that deliver the right information to the right person at the right time and in the right level.

- Delivers information systems that determine working manner of the customers and cause measurability of works, in the field of production, development, implementation and integration of information technologies.

1.16.2 Case 2: The Application of Central Hospital Appointment System (CHAS)

Generally, the main problems of developing countries, like Turkey, are the financial problem and lack of the specialist doctors. Moreover developing countries face with the challenge of using existence resource in effectively.

The project which was designed by the cooperation of the Turkish Ministry of Health and Turk Telekom can be good example for developing countries common problems. We believe that the project Central Hospital Appointment System (CHAS) must be assessed in the ITU's platform.

What is the CHAS?

CHAS is a kind of service that helps citizen for make an appointment for the health centres according to needs of the citizens.

Firstly, citizens must call the number 182 in order to benefit from this system. The alive operator will answer the call. The main purpose of the call centre is to direct the citizen to the most suitable health centre. Of course, citizen can declare his/her demand about the name of hospital and the name of the doctor. Call Centres try to help the citizen to realize his request. However, if citizen's request is not suitable in the selected time slot, call centre can direct the citizens another health centre. Moreover, Operator must interest the problem of the citizen intimately. If first aid information is needed, Operator can help; also during emergency situation Operator can inform emergency teams like ambulance etc.

The citizens also benefit from the number 182 by expressing their concerns and their complaints about the health services. Operators interest and note the complaints, and they send their notes to the relevant division of the Health Ministry.

Basically, how does it work?

- 1) In order to benefit from the services, the citizen must call the number 182. The citizen can use either fixed or mobile phones.
- 2) The alive operator will answer the call. The citizen must share his/her identity number by operator for acceptance of request.
- 3) Citizen declares to operator to which hospital he wants to go and which doctor he wants to contact.
- 4) Operator checks the agenda of the relevant hospital and relevant doctor.
- 5) Operator informs the citizen about the available time slot.
- 6) If the appointment date is not suitable for citizen, Operator can suggest alternative time slot.
- 7) After the agreement, the talk is finished.
- 8) Citizen must be in hospital 30 minutes before the appointment time and Citizen must make registration at the hospital.
- 9) Citizen can cancel the appointment time with by 182 thereafter.

CHAS system has 4 main processes:

- Main Process 1: Processing the appointment request
 - After calling number 182, the citizen must give his/her identity number.
 - After the endorsement of the identity number of citizen, the appointment is approved by the Operator.

- If Citizens doesn't know his/her identity number, Citizen must share his/her identity information with operators.
- Main Process 2: Cancellation of Appointment (by Citizen)
 - If the citizen wants to cancel the appointment, she/he must declare his/her identity number or information by calling the number 182 again.
- Main Process 3: Cancellation of Appointment (by Doctor)
 - If the Doctor has some urgent work to do, appointment can be cancelled.
 - Patients are called by the operators
 - New Appointment time is offered.
- Main Process 4: The Pursuit Of Appointment
 - Operator also controls all appointments day by day.
 - After the appointment time, Operators call the citizens who benefit from CHAS
 - The purpose of this call is to learn the view of the citizen about CHAS services, if there are important complaints; the complaints are recorded than the results sent to Center of the Minister of Health.
 - Moreover, Surveys are applied by the operators.

General Survey Question:

- Did you examine in the appointment time?
- Did your doctor examine you in the appointment time?
- If another doctor examined you, how they explained this situation?
- In general, how many points you give CHAS? (1=minimum, 5=maximum)

Figure 15: Example of CHAS survey

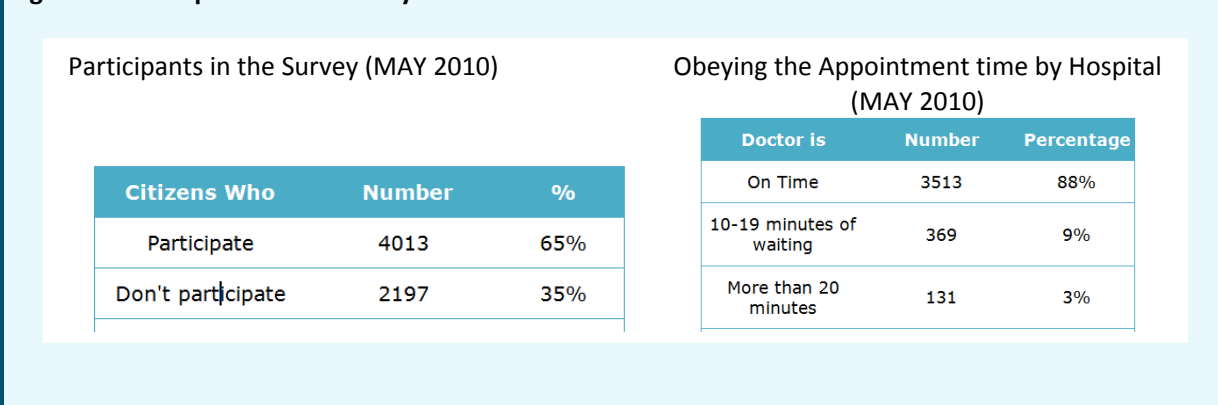

Few Solution of Question

The organization chart of Hospitals for CHAS

The main responsibility of Hospital is to organize the CHAS system properly. Each Hospital employees must work for the success of the CHAS.

The assistant head of hospital is the main responsible for the project. She/he must prepare the working agendas of each doctor in the hospitals. The agendas must be approved by head of hospital.

Responsible of Working Agenda controls the fulfillment of the all working agendas.

Responsible of CHRS Software deals with technical aspect of project.

Reception Employee must welcome the citizen and they must answer all questions of the citizens.

The Duty of Doctors

- Hospitals must prepare each doctor's working agenda for every month,
- Doctor must accept and sign the conditions of working agenda for every month,
- Doctor must obey the conditions of the working agenda properly.
- Doctor may not be in holiday during process.
- Doctor can cancel the appointment only if acceptable urgent conditions are occurred.
- Working agendas of Doctors is controlled by the assistant Head of Hospital.
- The purposes of CHAS Projects are the following:
 - To increase the efficiency and the quality of health services which are given by Turkish Health Ministry.
 - To increase the public satisfaction about health services.
 - To compose the limited resources allocation (the usage of the man power and equipment).
 - To decrease the crowd density in the hospitals.
- CHAS will also help for equal services rights of the people. With this system, people will access to the equal health services.
- The health workers will work more efficiently.

Figure 16: Example of CHAS or doctors

Doctor who obeys the appointment time

(MAY 2010)

Doctor	Number	Percentage
obeys appointment time	3852	96%
doesn't obey appointment time	161	4%
Total	4013	100%

The Cause of Doctors who are not on time the appointment time

Doctor was	Number	Percentage
On Vacation	48	31%
In Surgical Operation	25	16%
In Different Department	13	8%
In Lunch	5	3%
Unknown	65	42%

How many points you can give for CHAS?

Point	No of People	%
5	3206	80%
4	544	12%
3	178	6%
2	48	1%
1	37	1%
Total	4013	100%

Did you experience a problem with call center?

Answer	Number	Percentage
No	3963	99%
Yes	50	1%

Some years later, the data which will be obtained by CHAS sources can be used for reshaping the Health Policy of Country.

Propagation of CHAS project

A CHAS service firstly was started in Erzurum and Kayseri cities in February 2010. These cities are among medium sized cities of Turkey. After that, the services were propagated 10 other cities of country on summer 2010. Those cities are chosen from different geographical part of the Turkey.

The Support of Turk Telekom

In 19 August 2009, Turk Telekom and Minister of Health signed the cooperation agreement. According to the agreement, Turk Telekom accepted very critical commitment.

For realizing this project, Turk Telekom finances all technological and human resources infrastructure. Turk Telekom employed 150 operators in Call Centre which is situated in Erzurum.

Moreover, Turk Telekom increased the capacity and the scope of the existence telecommunication infrastructure of Turkish Ministry of Health. Almost all Turkish Hospitals have broad band Internet connection.

Today, Turk Telekom implements CHAS project in the 10 different cities of Turkey. However, the duration of the agreement which signed between Turk Telekom and Ministry of Health will finish at the end of the 2010.

Ministry of Health wants to propagate the scope the CHAS services to 81 cities of Turkey. Therefore, Ministry will invite tenders for the render of CHAS services in all 81 cities of Turkey. Turk Telekom is also candidate for the new period.

Conclusion

CHAS is very important part for the transformation process of the Health Sector of Turkey. If Turkey increases the scope of the CHAS to the all cities of Country properly, total efficiency of health sector will be higher and the crowd in the hospitals will be decreased and the hospitals will be better places for working comfortably.

1.16.3 Case 3: Acibadem Mobile Emergency Health Bundle Services

Introduction

²¹In order to develop the national e-Health policy, the creation of a national strategy is critical. Governments must work to implement the e-Health policy. During the creating of a national e-Health policy, the support of the private companies is needed. Especially, according to World Trade Organization (WTO) Agreements, many countries privatized their incumbent companies and they created the competitive market in the telecommunication sector. Moreover, in health sector, many private hospitals worked with public hospitals. The governments must support the cooperation between telecommunication companies and hospitals in terms of regulation. The incentive of the government leads to very efficient cooperation between the health and the telecommunication sectors. The e-Health Master Plans must contain the financial and regulative incentives for sectoral cooperation.

In this document, the cooperation between Turk Telekom (incumbent private telecommunication operator) and Acibadem Hospital (Private Hospital Groups) is shared.

Stakeholders

Turk Telekom is the leading communications and technology company in Turkey with a \$14.5B market cap. Also:

- Strong consumer base: 16.3 M fixed voice, 6.5 M broadband, 11.5 M mobile subscribers.
- Extensive service and distribution networks: access to 2.5 K corporate, 179 K SME, 1.5 M SOHO accounts with 1K+ dealers.
- Diversified portfolio of businesses; owns verticals such as education & online games.
- Operates digital platforms: IPTV, WebTV and mobilTV.
- Ability to attract high caliber technical human capital in Turkey (in recent year, out of 100K applicants, recruited 5K+ mainly technical people).
- Strong ties with regional telecommunications operators: access to a large population base.
- Strong financials & willingness to invest for high growth areas.

Acibadem Healthcare Group has been providing its services through its 24 branches spread all over the country with it's over 7.000 employees, 1.350 of whom are physicians since 1991.

On the other hand, Acibadem Mobile Healthcare Services Inc. was established in July 2008, as a partnership between Acibadem Hospitals Inc. (80%) and Acibadem Polyclinics Inc. (20%).

Company's Goal

Acibadem Mobile Healthcare Services aims to provide mobile healthcare services at the highest quality level possible, in line with the mission, vision and quality policies of Acibadem Healthcare Group, which was selected as the "Most Valuable Brand" of Turkish healthcare sector in 2007.

²¹ See document [SG02-INF-0056](#)

Medical Team

With its over 300 employees, over 100 of whom are physicians as of the end of year 2008, Acibadem Mobile Healthcare Services provides mobile healthcare services to individuals and entities with its leading edge mobile medicine technology.

Definition of Services

The service is called Turk Telekom Acibadem Mobile Health Services (TAMHS). The TAMHS was created by the cooperation between Acibadem Hospital and Turk Telekom. The TAMHS which is the bundled service includes different services: Emergency Health Insurance, Medical Coaching, Emergency Healthcare Services (Land and Air Ambulances), Home Care Services, Resident Infirmary Solutions, Mobile Healthcare Screening, Organizations (Providing mobile healthcare services for various events), Telemedicine (Remote access online healthcare service), Affinity (Group) Programs.

The bundled services are provided by the Acibadem Hospital Staff for 16 million Turk Telekom Customers. The customers who benefits from the bundled health services, pay their fee with Turk Telekom invoices.

Purpose

Turk Telekom offers this beneficial bundled health services with very suitable conditions to the millions of people. Because of the -economies of scope advantages, these important services can be provided very cheap conditions for each customers of Turk Telekom.

Besides, the number of fixed subscriber decreases day by day in all worlds of fixed markets. The health services can be very good opportunities for increased loyalty of the customers.

The Main Characteristics of the Services

For 1 year, Turk Telekom customers can benefit from TAMHS in 7 days 24 hours.

With AHMS;

- Customer can be informed about pharmacy on duty.
- Health consultation services.
- For subscriber and his family (max. 3 people), a free fully equipped ambulance service.
- For subscriber and his family (max. 3 people), a free 1 year health insurance.

The subscriber and his family's health reports and talks are stored with property rules. Those data can be used again in further health problems. The health insurance is valid in all private hospitals in Turkey. Insurance includes all charges related with treatment, room and intensive care. The charges couldn't be exceeding approximately 4000 U.S. dollars. If the subscriber has insurance, it is not a barrier for benefit from AMHS.

Target Audience – All Turk Telekom subscribers and their family (max. 3 people, until 65 years of age)

Application Requirements

- All Turk Telekom PSTN subscribers can benefit from the health services
- Subscribers must be already Turk Telekom user for at least 2 months (60 days).
- Subscribers, who benefit from these services, can also benefit from other Turk Telekom services.
- Customer must accept to be subscriber of Turk Telekom for the following 12 months.

Figure 17: Turk Telekom Acibadem Mobile Emergency Health Bundled Services (AMES)

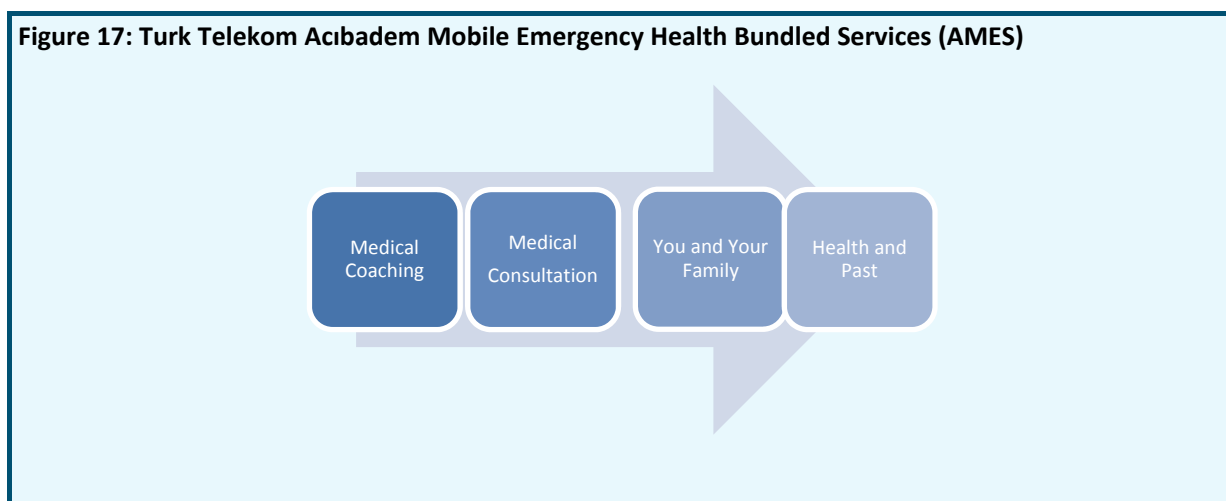

Turk Telekom Acibadem Mobile Emergency Health Bundled Services

AMES includes 4 different parts.

Medical Coaching

For 1 year, Turk Telekom customers can benefit from TAMHS in 7 days 24 hours.

Medical Consultation.

Customer can be informed about pharmacy on duty and other important information for free.

You and Your Family

In emergency situations, subscribers and their family can benefit from a free fully equipped ambulance service and a free 1 year health insurance.

The subscriber and his family can benefit from all advantages in all parts of country.

Health and Past

The subscriber and his family's health reports and talks are stored with property rules. Those data can be used and shared in further health problems.

How Customer Can Apply To The Services?

- Call Center

The Customer can apply to the campaign by using Turk Telekom Call Center.

- Turk Telekom Office

The Customer can apply the campaign by signing application forms in Turk Telekom offices.

Conclusion

Technological improvements contribute to the development for the new medical solution. Besides, Information and Communication Technologies are very important for spreading health services efficiently in the country. Especially, mobile broadband technologies serve new opportunities for the health sector.

Governments must support all e-Health investment in their countries. Governments must create economic incentives to create suitable environment between Health and Telecommunication sector.

The cooperation between Turk Telekom and Acibadem Hospital can be a good example for the competition environment. This cooperation serves very suitable bundled health services to the customers. The bundled service includes health insurance, first aid, family health opportunities in the same time.

The convergence between health and telecommunication sector can produce very successful solutions. International Telecommunication Union (ITU) must work for creating the right incentives between these two different sectors.

1.17 Uganda: Uganda's Approach to Implementing Broadband Connectivity in Underserved Areas

1.17.1 Introduction

²²Uganda Communications Commission (UCC) established the Rural Communications Development Fund (RCDF) to stimulate provision of telecommunications services in the rural and underserved areas. The RCDF is therefore acts as a mechanism for leveraging investments in communications infrastructure and services in rural underserved areas of the country. This was recognition of the fact that although the sector had been liberalized and opened to competition some parts of the country which were non-commercially viable would not attract private capital for investment in infrastructure and services.

The RCDF main objectives include to provide access to basic communication services within a reasonable distance; ensure effective investment in rural communications development and to promote ICT usage in Uganda.

1.17.2 Uganda's Universal Access Policy Framework

Uganda's Universal Access Policy (2010) is developed within the premise of the global development agenda, the Millennium Development Goals (MDGs), to which Uganda is one of the signatories; and its country-specific National Development Plan (2010) that was originally linked to the national vision called Vision 2025. The policy is also developed building on the previous universal access policy (2001) and within the framework of Uganda's ICT policy and telecommunications policy.

Objective

One of the main reasons why the Internet has not spread to the rural areas are the cost of access, insufficient bandwidth and power issues and more important for the rural communities, illiteracy and the absence of relevant local content in vernacular. The new policy therefore has the main objective of ensuring provision of broadband connectivity and supporting the development of local content. However, the main impediment for the ICT sector in Uganda today is the lack of broadband infrastructure network meant to accelerate access and use of the Internet in particular and ICTs in general. This is especially because of the heavy capital requirements that cannot be left to the private sector alone and thus requiring special intervention from government.

Broadband Policy Implementation

Uganda government has embarked on supporting the interconnection of all higher local governments' capitals and major towns with a national data backbone infrastructure so as to enable provision of wide array cost effective ICT services to the users. This expected to facilitate the establishment of institutional data access points with initial focus on vocational, tertiary and secondary educational institutions, and government health units for levels IV and III.

Broadband connectivity will be provided for selected sub-counties to connect to the high speed National Backbone Infrastructure. The connection is considered as a 'last mile' solution for the sub-counties. To this end, a detailed study to determine the most cost effective technological solutions (wireless, cable) that could be implemented for each location is underway. Additionally, the study will help in identifying

²² Contribution: Moses Okello, Uganda Communications Commission (UCC), Uganda. See document [SG01-INF-0017](#)

the districts that will not be covered by the national backbone infrastructure. The backhaul links will then be deployed to link such sub-counties to the identified districts.

The initial proposal is to outsource the design and implementation of the proposed access network to competent telecommunications service providers. The project once implemented is intended at lowering the price of bandwidth paid by the consumers while providing high quality and a wide variety of broadband services. The project will also entail providing computers and capacity building or training programmes to the end users such as schools, health centres and local governments.

1.17.3 Expected Benefits

- E-government: The project will help in collecting information from lower local governments upwards to the central government. The information will be part and parcel of the national demographics and other socio-economic related statistics.
- E-education: The project will facilitate e-learning and already this is gaining popularity in the country. For example major local universities are having satellite campuses in upcountry locations in which long distance and online education are now being offered.
- E-health: The project will facilitate data and voice flow from the rural communities to the health centre onwards to the district hospitals and regional referral hospitals and finally to the national referral hospital. The reverse flow will happen. Additional traffic is expected between the Ministry of Health head office and the district offices and also between the ministry and the health centres.

1.17.4 Conclusions

Internet penetration, access and usage in Uganda is still very low and is estimated at (5%) users of the total population. This is also largely confined to urban commercial centres owing to commercial considerations by the private service providers. Although Uganda's previous policy had supported the installation of Internet points of presence in all the underserved districts, the internet bandwidth speeds and quality of service issues (outages) has been of major concern by the end users.

Therefore the new policy objective is expected improve broadband uptake in selected underserved areas. This is envisaged offer lessons and experiences for developing a national broadband policy and subsequent rollout strategies for the country. Therefore ITU-D Study Group meetings offers Uganda an opportunity to gain experiences on how other countries are addressing this developmental concern.

1.18 Uzbekistan: Health Management Information System in Uzbekistan

²³Currently in Uzbekistan a wide range of socially significant reforms are carried out. There are the administrative reform, education and health care reforms, etc. Much attention is also paid to the development of information technologies – informatization of state agencies and set up the ground for future e-Government in the near future.

To speed up the introduction, use and further development of computer information systems, the program of computerization and ICT development in 2002 – 2010 has been adopted by the Government of Uzbekistan. The program was designed to create conditions that will allow Uzbekistan to achieve a higher level of ICT penetration in all spheres of life, including public administration and social activities.

²³ Contribution: Mirodil Baymukhamedov, Ministry of Health, Uzbekistan. See document [SG02-INF-0039](#)

1.18.1 HMIS in Uzbekistan

Integrated Health Management Information System means a multi-tiered system consisting of software and hardware in departments and divisions of the Ministry of Health, medical institutions, laboratories, sanitary-epidemiological surveillance departments, research institutes and universities as well as in departments/units of medical statistics. The development of the Health Management Information System should be based on the use of Internet technologies and integration of all available information resources into a single corporate network of the Ministry of Health.

The Ministry of Health approved the concept of HMIS (Decree №99, March 31, 2009) after detailed considerations and evaluations. It was selected a star type architecture of HMIS with the Data Center located in Tashkent based on open integration-communication platform. The structure of HMIS is presented in Figure 18. The decision to select the centralized architecture was well justified at this moment because the environment is not well prepared for computerization and it is needed some control. The Healthcare Integrated Platform is the common telecommunication and information infrastructure and it is a backbone of HMIS. It will be built component-wise, mutually connecting all entities into powerful common infrastructure. Of course, each entity has its own Local Area Network (LAN). This approach also allows adding or subtracting any component as appropriate and needed. It is important to stress that one of the main advantage of such architecture is scalability.

The all organizations belong to the Ministry of Health will transmit their information according to the agreed protocol directly to the Data Processing Center which is the repository of all information of the Ministry. The Data Center will be connected with all information systems and databases such as "Management and planning of human resources of health care system", "Monitoring of infectious diseases", "Basic register of blood donors and persons not permitted to donate", "E-passport of health facilities", etc.

Figure 18: Architecture of HMIS in Uzbekistan

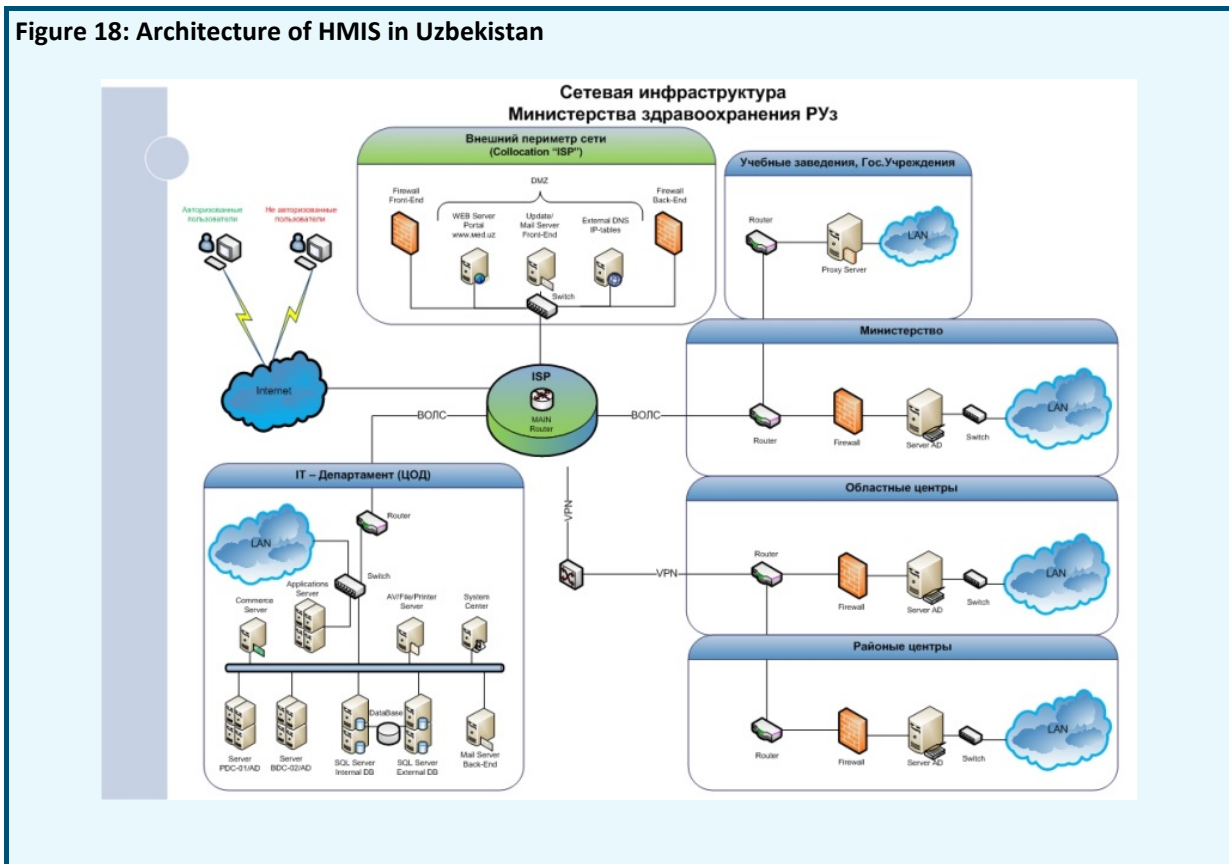

Openness and standard pursuance of selected HMIS architecture enables interconnection of any other kind of register or database that healthcare service process requires. Furthermore, central system management reduces administrative costs.

The Data Center will get raw data without any intermediate levels and process it into required format, presentation or report. Data Processing Center (DPC) of Ministry of Health, which will be the heart of the HMIS should also include a Service Center and Call Handling, which is a standard feature of any data center. The access to the information will be restricted and regulated.

The advantages of this architecture are the following:

- Direct transmission of primary information in the database eliminates the possibility of modifying the original raw data.
- Instant display information in real time by any criteria.
- A single data repository eliminates duplication.
- Paperless process will bring some saving.
- Only the owner of raw data has a right to make correction of his presentation.
- Manager will get a chance to view the situation at any time.
- Quick search of any information related any region & Sampling only interest criteria.
- Universal access via the Internet (Intranet) in the presence of access rights.
- Complete elimination of middlemen, who collect and aggregate data.
- High level of security.
- Opportunity to get quickly any analytical or statistical reports.

1.18.2 Activities Undertaken by the Ministry of Health

In line with the approved HMIS concept and according to available resources, the Ministry of Health is providing the number of servers and computers to organizations in order to connect them to corporative information network.

The Ministry of Health decided to establish a database and distribution of computer equipment based on the concept adopted, with phasing for connection of each organization to the corporate network of the Ministry. The introduction of some e-Health services is considering as well.

The main objective of e-Health services is to provide expert medical help to the people situated in rural and remote areas where highly qualified and experienced doctors are not available. Improvements in all aspects of information and telecommunication technologies are enabling health and healthcare organizations to share information electronically across previously impossible distances and borders, and bring clinical practice and administrations alike to the healthcare staff in any location. New technologies are emerging and rapidly maturing. In some cases even faster than users can absorb and integrate them.

The introduction of the telecardiology monitoring service (and other e-Health services) will give the opportunity to provide quick and highly needed service at a distance for many patients suffering from cardio-vascular and other chronic diseases.

1.19 Zambia: Project MWANA

²⁴Project Mwana is one of e-Government service that Ministry of Health has implemented with the help of the cooperating partners to improve early infant diagnostics services, post-natal follow up and care using mobile phones.

²⁴ Contribution: Beaton Sibulowa, Ministry of Transport, Works, Supply and Communication, Zambia. See document [SG02-C-0215](#)

1.19.1 Country Overview

Zambia has shown growth in attracting investment in the Information and Communication Technologies (ICT), Sector. The sector has recorded over 42 percent penetration rate growth compared to 0.02 percent recorded 14 years ago. The ICT sector have continued to pour in since the country launched the policy in 2007 adding that the policy has created an environment for the growth of the sector. Mobile manufacturing company and various internet and mobile service providers are some of the investments that the country has attracted. The unfortunate scenario is that most of development are concentrated along the line of rail, leaving large areas in the rural and remote place unserved or underserved.

In Zambia, large numbers of infants are infected with HIV either at delivery or when breastfeeding. If no interventions provided, most of these children who contract HIV from their mothers die before the age of two years. These deaths contribute to the high levels of national under-five mortality rate. The government made it mandatory to test every infant born and begin treatment within the first twelve weeks of life.

The challenge faced by the Ministry of Health in particular area was how to transmit infant diagnostics services results from the three (03) test centres (Laboratories) in the country to the respective remote places within the shortest possible time. The turn-around time under the courier systems available would take an average duration of forty-two (42) days to complete the process, a period too long for a mother wait without breastfeeding. This challenge led to the birth of Project Mwana in 2009.

Objectives and Strategies:

- To strengthen early infant diagnosis with an aim both to increase the number of mothers receiving results and to reach mothers in a faster, more efficient manner using the SMS application (m-Health).
- To improve the rate of postnatal follow-up, increasing the number of birth registrations for clinic and community births, while also raising the number of clinic visits for mothers through community-health worker tracing using the “RemindMi” application.
- To enhance service delivery of government to its citizens.
- To reduce bureaucracy, turn-around time in providing government services.

Activities Implemented:

- Procurement of ICT Infrastructure (Servers and Connectivity) for the project.
- Development of Project Mwana using RapidSMS, a free and open-source framework for building mobile application for dynamic data collection, logistics coordination and communication, leveraging the basic short message service mobile technology.
- Piloted in the project 6 provinces across Zambia, servicing 31 clinics and the pilot evaluation showed that it had substantial positive health impacts.
- Scaling the project nationally between 2011–2015.

Technologies and Solutions Deployed:

- SMS technology – powerful innovation that in Zambia has reduced delays in receiving early infant diagnosis (EID) DBS HIV test results, improved communication among health care providers and community volunteers, and more important, encouraged patients to return to the clinic for their test results with greater confidence.
- RapidSMS Technology – addresses Early Infant Diagnosis (EID) of HIV. SMS messages are used to send the HIV results from the labs where they are processed to clinic workers in facilities where the samples are collected. The results arrive on phones in smaller clinics and SMS printers in larger

facilities. The system also tracks samples and provides real-time monitoring for the province and district officials.

- RemindMI RemindMi addresses Patient Tracing for post-natal care. SMS messages are sent to Community Based Agents who seek out caregivers and infants and ask them to return to the clinic for 6 day, 6 week and 6-month post-natal check-ups or special circumstances, such as results arriving at the facility.

Changes and Outcomes Achieved

Project Mwana RapidSMS pilot reduced delays in transmitting results from the HIV test laboratories to the rural health facilities via SMS message from the average of 42 days to an average of 4 days. To date, the project has been piloted in 31 predominantly rural districts of Zambia and has produced desired results, which has prompted the government to schedule a national scale up program.

1.19.2 Challenges and Success Factors

Challenges:

- Ownership of the project prior to initiation, and coordination among the partners.
- Sustainability of the project after scale up and when cooperating partners hands over the project totally to government.
- Lack of investment in research and development in ICT.
- Digital gap between the Urban and the rural areas.
- Socio-economic disparity.

Success Factors:

- Leadership taken by government on the project & Government beginning to fund the large component of the project

1.19.3 Lessons Learned and Next Steps

- Government leadership
 - When undertaking a project in the government, Users should be involved from the beginning project. This step helps in understanding user requirements and processes involved to complete tasks.
 - There is need to integrate the project into long-term planning.
 - Integrate data into district reporting.
- Locally sourcing – Employ a permanent local software development team; Have a permanent project manager who can coordinate partners; Create government-led working groups.
- Cost control
 - Negotiate with telecom companies for scale, not pilots.
 - Utilize the phones people have rather than purchasing and supporting a national phone system.
 - Create district-level training teams.
- Co-creation
 - Make decisions based on identified needs of the end users.
 - Create the tools with the people who are going to use them.

- Test early and often; don't worry about failing and stay adaptable.
- Use open source tools that can be customized to local needs.

1.19.4 Next Steps

A national scale-up plan has been developed, commencing with a preparation phase and then shifting to an iterative phase where clinics are trained and added to the system and the problems and successes of the additions are evaluated. The aim is to achieve national scale by 2015, with health facilities offering early infant diagnosis services. The preparation phase will focus on solidifying the technical, physical, monitoring and human infrastructure to allow the system to handle the stresses of scale. Throughout the scale-up process, the project will be closely monitored to ensure the systems are having a positive effect on the targeted health challenges.

Annex II: Lessons Learned from e-Health Implementation: Knowledge

The following examples of strategies and implementation of e-Health services and devices were cordially provided by members of ITU-D Study Group 2 Question 14-3/2.

2.1 Czech Republic: 1. Interoperability in Integrated Biomedical Systems

¹Our work on biomedical research projects has led us to the conclusion that successful integration of partial solutions is strongly dependent on the issue of interoperability of medical devices and information systems. It comprises problems of standardization of data acquisition, communication, processing, and storage; and connected problem: correct data mapping between different ICT applications. The key issue is the ability to understand the semantic content of the exchanged information.

With development of more advanced sensors, body area networks and ICT the focus will be on the integration in larger systems collecting and processing large volumes of data, evaluating more complex situations and scenarios, precise identification of potentially dangerous situations and finding solutions (e.g. alarms in case of health or life threatening events, access blocking in case of security attack). Key issue is in information reporting and visualization (as widely used in Business reporting). Although many issues have been successfully solved and introduced either in applied research or in development of prototypes or final products there are still many problems on the waiting list. There is a possibility to use an integration platform; however the systems should be able to communicate directly using world-wide recognized standards without third party.

2.1.1 Technological Trends

If we want to develop flexible e-Health, assistive technology (AT) or ambient assisted living (AAL) systems we have to define standard interface that allows “plug-and-play” type of connection. Especially AT and AAL systems are composed of different hardware and software modules that must communicate. The basic condition is that the receiver understands correctly the content of the message. Thus it is not sufficient to be able to receive the message, i.e. to understand the syntax of the message, but it is necessary to understand the semantics. This requirement implies development of data model that maps semantic content from the data received from the devices into an information system that is usually used for collecting and evaluating data from monitored persons. Also there must be guaranteed latency of the information transition and a possibility to verify the source of the message (for example by PKI infrastructure) and to clearly determine the time order of messages. We propose a system architecture allowing above mentioned interoperability. Interoperability may significantly influence effectiveness both of design and development of an integrated system and of its routine operation.

Integrating information deriving from different sources and implementing it with knowledge discovery techniques allows medical and social actions to be appropriately performed with reliable information, in order to improve quality of life of patients and care-givers.

Currently the mobile technologies, sensors and other devices enable collecting vast amount of data of individuals. This multi-parametric data may include physiological measurements, genetic data, medical images, laboratory examinations, and other measurements related to a person's activity, lifestyle and surrounding environment. There will be increased demand on processing and interpreting such data for accurate alerting and signalling of risks and for supporting healthcare professionals in their decision making, informing family members, and the person himself/herself.

¹ L. Lhotska (1, 2), M. Bursa (2), and M. Huptych (2) ¹ Czech Society for Biomedical Engineering and Medical Informatics & ² Czech Technical University in Prague, Department of Cybernetics, Czech republic. See document [RGQ14.3.2-C-0014](#)

Recent development in ICT [1] [2] shows that it is almost impossible to design and implement a complex system as fixed to certain hardware, operating system, and infrastructure. A possible solution is to create a tiered integration platform. However it is usually ineffective and expensive (to create and maintain). Thus it is necessary to develop such architectures that will be easily extensible and modifiable. For easy extensibility the basic requirement is to understand data exchanged between individual parts of the system.

2.1.2 Proposed Architecture

Based on the facts mentioned above we have tried to define requirements and subsequently system architecture that would satisfy these requirements. The proposed architecture [3] covers the whole chain from data acquisition/measurement over data collection, identification, transformation up to evaluation and storage in an EHR system (see Figure 19). From the description it follows that there must be interfaces between individual modules. To allow the “plug-and-play” approach the interfaces must be.

Figure 19: Proposed architecture of the chain from medical devices to EHR and HIS

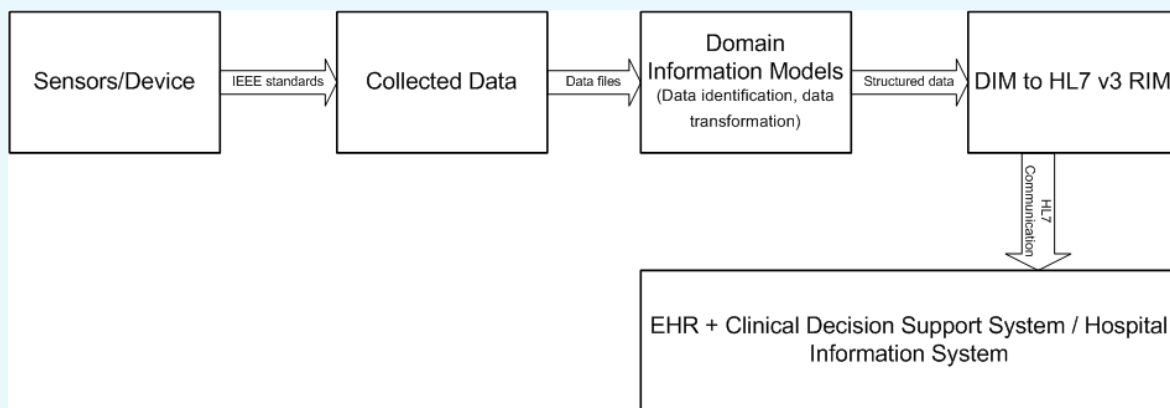

Based on well-defined standards, we have in mind especially following categories: ISO units for measurement of physical quantities, ISO IEEE standards in communication, standard file formats in software area, HL7 standards on the side of information systems and guarantee data accessibility even after long time when there would be data for long-term clinical studies. Another inseparable part of the architecture is constituted by data models. The models will ensure correct exchange of data between devices and information systems. This part represents a great challenge and at the same time the greatest space for future solutions because the correct mapping of acquired data onto a data model that describes electronic health/patient record is not satisfactorily solved yet. A crucial part is to select proper backend solution (such as information systems, databases, platform, etc.). The architecture must also keep pace with the versioning of the information models. Each batch of data must reference the version of information model that was active at the moment the data was acquired and the model must be available together with the archived data.

The proposed architecture is not necessarily centralized. It can be composed of highly distributed units utilizing, for example, multi-agent platforms as software infrastructure [4]. For example, it can be used for more efficient data handling. For data storage there can be smaller local storages and a central data storage used for different types of data. Also replicated and/or distributed storage can be used. Since there can be collected health state data and daily activities patterns the large volumes of data can be stored locally and based on the data analysis during system development the professionals (e.g. medical doctors) can define, which type of data should be sent to a central data storage maintaining electronic health care records.

2.1.3 Current State in Czech Republic

Legislation

The state of interoperability in biomedical systems is strongly influenced by legislation. Currently the law on sensitive information has been introduced with no regard to current e-Health and EHR development in EU and from many aspects it blocks the e-solutions even in government projects. Regarding the Health Records, there is regulation that covers health documentation in paper form only. No legislation exists regarding the EHR. There has been a pilot EHR project (called IZIP), however the funding has been suspended and the project represents only a health-book merely. The IZIP project did not use any interoperable standard and the application data interface is not available, so no third party can take advantage of it. Moreover, no developers of hospital information systems (HIS) are forced to use any interoperable standards.

Communication

Although the meetings regarding e-Health are taking place, usually no consensus is reached as there is a lack of communication and the conversation usually gets stuck at unimportant details. The government representatives do not act as active intermediates between IT and medical experts. Also there is not sufficient participation from the standardizing organizations. The e-Health is not presented to the medical experts and public in understandable form. They see more an bureaucratic burden than any advantage. From our experience in working with medical doctors, there is usually no use of explaining highly-sophisticated technical issues. It is better to present a GUI of an application, schematic diagrams and demos.

Financial Issues

There exist many opinions against interoperability implementation. At the first place there is usually the financial aspect: IT developers, government, health-insurance companies, medical facilities and even patients are asking the crucial question regarding financing. The need of functional e-Health solution is often overlooked without understanding the negative consequences. As mentioned above, there it lacks a constructive debate and communication in the direction to patients and the society that would unify the heterogeneous groups.

2.1.4 Conclusions

With respect to future development and possibility to sense and store far more larger volumes of heterogeneous physiological parameters the issue of interoperability becomes more and more important. Interoperability may significantly influence effectiveness both of design and development of an integrated system and of its routine operation. It will become more and more important with the development of telemedicine, home care and possibility of remote monitoring of patient state. As the technology is developing very quickly we have to assume that new types of sensors and devices will appear. The newly designed and developed systems must be necessarily created as open modular systems allowing direct connection of the new sensors and devices without any need of modification of the communication and data input. Possibly new data processing module will be added. However if we only replace an old type of sensor by a new one delivering the same data (concerning semantic content) in higher quality there should not be any need for changing the software part.

Presented issues show that successful applications need coherent approach of experts from many different disciplines, i.e. information technology, electronics, communication technology, medicine. Standardization can make the way from an idea to an application much easier and faster. Thus acceleration of standardization process represents a key issue. It is important that involved companies, researchers, and standardization bodies agree and cooperate towards the ultimate goal – defined standards. There has not been space to mention the expressive power of ontologies, their flexibility, extensibility, and their potential in various applications in biomedicine. We should be aware of their potential for future applications. It is expected that new tools will be developed that allow more efficient

work with ontologies, including development of virtual ontology libraries, or ontology visualizations. We should also mention the inevitable spread of no SQL databases. These might find their use in the EHR solutions due to their inherent properties.

For the Czech Republic, there is no informative material that would present medical experts the advantage of the electronic solution and persuade them that the change can be carried out with minor invasion. The question is whether the impulse should come from government, medical experts or even patients. There is missing a communication based on the view from the position of the patient that might influence medical doctors, medical doctors would apply to medical insurance companies, medical insurance companies to the government, etc. Currently there is no solution for m-Health, so there is perfect opportunity to start from scratch with correctly defined interoperable structure using widely acknowledged standards.

Electronic signature is widely used and understood. However the medical records should also have a guaranteed timestamp that reflects the order of data-change. The permissions and authorizations for manipulation of medical data together with defined responsibility need to be defined.

Acknowledgment

This research has been partially financed by the research program "Information Society" under grant No. 1ET201210527 "Knowledge-based support of diagnostics and prediction in cardiology" and by the research program MSM 6840770012 of the CTU in Prague, Czech Republic.

References

- [1] D. Bernstein, E. Ludvigson, K. Sankar, S. Diamond, and M. Morrow. Blueprint for the Intercloud – Protocols and Formats for Cloud Computing Interoperability. IEEE Computer Society. Pp. 328–336, 2009.
- [2] J. Kaplan, et all. Roadmap for Open ICT Ecosystems. Berkman Center for Internet & Society at Harvard Law School. 2005
- [3] L. Lhotska, O. Stepankova, M. Pechoucek, B. Simak, and J. Chod. ICT and e-Health Projects. In Telecom World (ITU WT), 2011 Technical Symposium at ITU. Piscataway: IEEE, pp. 57-62, 2011
- [4] L. Lhotska, and O. Stepankova. Agent architecture for smart adaptive systems. Transactions of the Institute of Measurement and Control. Vol. 26, pp. 245–260, 2004

2.2 Japan: Case 1: Best practice of SaaS type medical network solution in Japan

2.2.1 Background

- ²There are increasing needs and financial concerns for healthcare services for the aging societies in Japan. ICT is one of the important tools to solve these issues. Fujitsu Limited introduced the SaaS type regional medical network solutions as a platform to share the medical information for the collaboration among healthcare related parties.
- In the developing countries, there are shortages of doctors and facilities for medical services, and the gaps between rural and urban areas. Telemedicine is one of the ICT applications expected to work effectively to improve the situation.
- We introduce the SaaS type medical network solutions in Japan for the study of its effectiveness in the different countries.

² Shigehiko Yasumura, Fujitsu Limited, Japan. See document [SG02-C-0184](#)

2.2.2 Overview of SaaS Type Medical Network Solution

Figure 20: SaaS type medical network solution

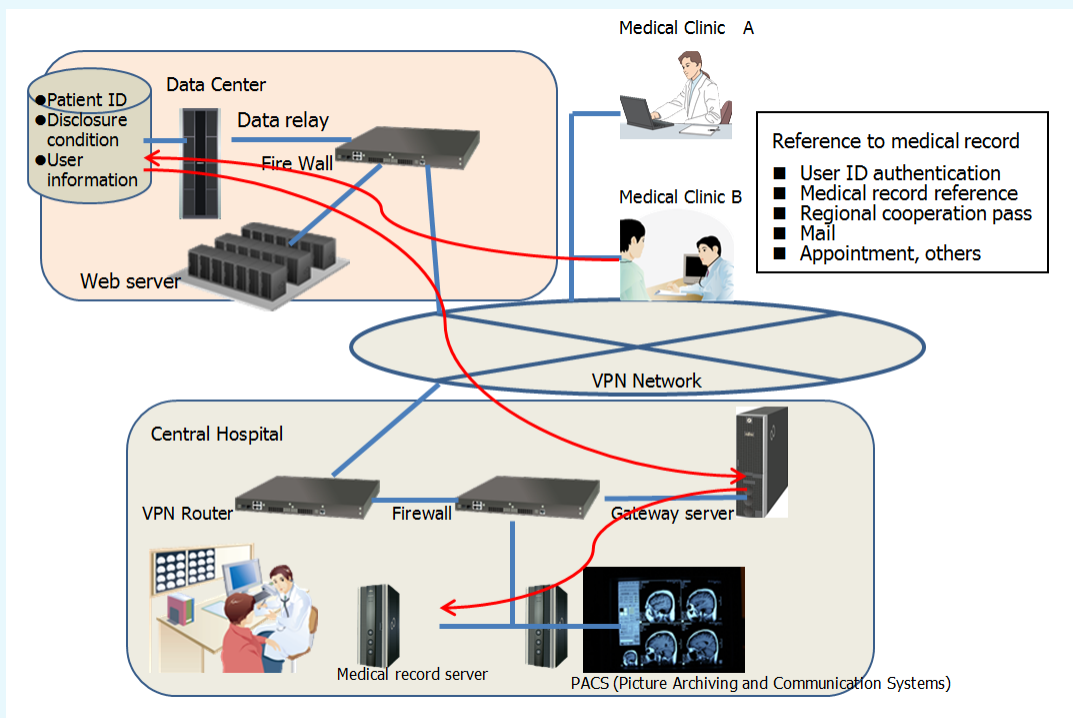

- As the medical record or other patient information are valuable personal information, it is necessary to keep such information secured from the threats, such as leakage and manipulation, vicious stoppage of services.
- The system (Figure 20), keeps the patient information stored at the original medical institutions where the patient information was recorded. When a doctor of other medical clinic would like to see the information remotely, he or she should access Data Center as an intermediate connection center. The Data Center will only provide gateway function without storages, and you will be released from the security risk for keeping the precious information outside of hospital.
- Off course, the Data Center is protected with strong facility management and security counter measures so that the medical institutions can use its services safely.

2.2.3 Key Benefits of Services

Applicable usage for developing countries

- In developing countries, the shortages of medical doctors and medical facilities and equipment for inspections or treatments are critical issues, especially in remote areas.
- Therefore, it is useful to realize the seamless medical cooperation among the doctors and medical institutions in rural and urban areas. Together with the telemedicine, this kind of service will help the patients to access the advanced medical service at major cities and the results can be shared with the local doctors.

Advanced features

- This system will enable relevant medical institutions to access the patient information, such as medical record, inspection report, MRI and other images, etc. according to the predetermined

condition of disclosure. Using this service as the common data base for hospitals, clinics, pharmacies, etc., we can provide the cost effective value-added advanced services to patients.

- For example, “Forwarding Cooperation” (name of service) is the introduction of patient from a clinic to Central hospital for advanced medical treatment and “Backward Cooperation” is the introduction of patients from Central hospital to clinics or Care centers so that the patient in the recovery process can use suitable rehabilitation facilities or would be introduced to home doctors for daily cares.
- For the advanced inspections such as MRI, the appointment with the special doctors of MRI can be made with the relevant information through the system. The MRI images can be reviewed at clinics remotely on the same day of such inspection.

Figure 21 shows the possible information sharing and medical support features.

2.2.4 Conclusion and further action items

With the use of SaaS type medical network solutions, we can realize medical care network connecting the servers and equipment at various medical institutions and share the information stored in the servers at each location. This will enable the effective use of advanced medical equipment and connection between rural and urban areas.

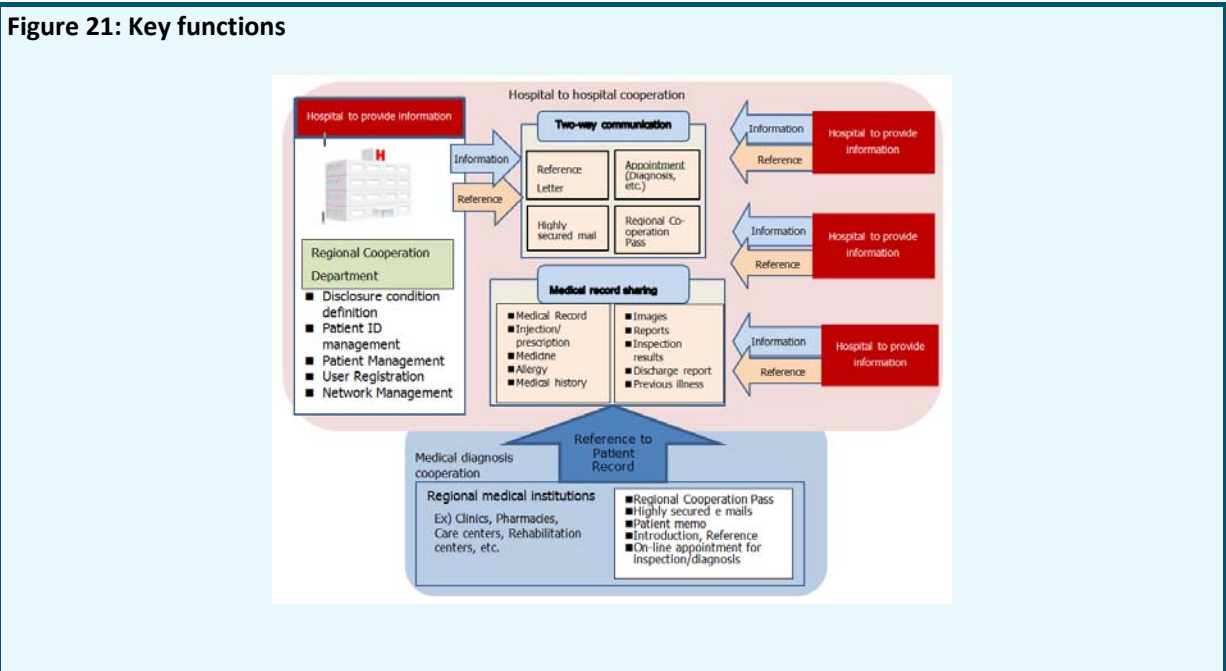

- To make the best use of the service, it is important to improve the availability, convenience and cost effectiveness so that the service will be used more frequently. By adopting the industrial standards, such as SS-MIX (*1) standardized storage and DICOM (*2) and others, we can cooperate with various vendors to increase the availability and cost effectiveness.
- After the Great East Japan Earthquakes, from a view point of BCP (*3), there is an increasing need to keep the data such as medical record in the secondary safety places. We should study further the solution for disaster management such as data back-up services.

Notes:

*1) SS-MIX: Standardized Structured Medical record Information eXchange. SS-MIX promotes the electronic processing and standardization of recorded medical information related to all the medical institutions.

- *2) DICOM: Digital Imaging and COmmunication in Medicine. A standard developed by ACR and NEMA to define the format for medical images, such as CT, MRI and CR, and the protocol of communication between medical imaging equipment.

ACR: American College of Radiology

NEMA: National Electrical Manufacturers Association

- *3) BCP: Business Continuity Plan. It is a plan to minimize the damages on the business assets and to keep the core business continuing or the prepared plan for early recovery from the damages in case enterprises face the emergency situations, such as occurrence of natural disasters.

2.3 Japan Case 2: Development of the Electronic Doctor's Bag

2.3.1 Introduction

³Japan, regarded as a super-aging society, must consider how to suppress the coming inflation of nationwide medical cost in the very near future. Moreover, a declining population in rural areas is accelerating the disparity of health care services.

To tackle these problems, the Japanese government is promoting the policy to encourage home medical care. The home care support clinic system, which intends to spread clinics operating house visit services on 24-hour schedules, was established in 2006. However, in the case of a small clinic, a physician may be forced to work in a sleepless and hard working environment. And transportation times to patients' homes reduce the efficiency of medical care.

On the other hand, information and communication technology (ICT) is a possible strong means to solve these social problems. Our research group established a consortium, "The Consortium for Medical Information Communications System in the Mobile Environment", on March 4, 2009. The consortium consists of a university and seven companies, and its main purpose is to provide the ubiquitous communications system for home-visit medical service, mass examination, emergency care and disaster medical care. In collaboration with the Sendai Area Knowledge Cluster Initiative supported by the Ministry of Education, Science, Culture and Sports, the consortium has newly developed a prototype of the ubiquitous communications system named "Electronic Doctor's Bag", which can easily send biological information with high-definition image of a patient in mobile environment. The main purpose of this system is that a nurse with the Electronic Doctor's Bag visits a patient's home instead of a doctor, but an equivalent face-to-face communication can be realized between the doctor in his clinic and the patient at his home, respectively.

The first prototype, which is called "P1" here, had been developed and evaluated by a few doctors and nurses. Their opinions were used to improve the system. In January 2010, the second prototype "P2" was developed and tested. In this report, the validity of the Electronic Doctor's Bag, including both prototypes, is reported.

2.3.2 The first prototype of the Electronic Doctor's Bag (P1)

System configuration

The features of the proposed system are as follows:

- Secure telecommunication is established between a patient and a doctor using personal authentication and encryption technologies.

³ Isao Nakajima, Department of Emergency and Critical Care Medicine, School of Medicine, Tokai University, Japan. See document [RGQ14.3.2-INF-0012](#)

- In addition to submitting biological information such as electrocardiographic (ECG) and blood pressure, pseudo face-to-face clinical examination can be achieved by sending high-definition images of a patient.
- The system is available in the mobile environment. So it is possible to examine in a patient's house without the Internet setup or in a moving vehicle such as an ambulance.
- The system can flexibly meet the diverse health care needs of various conditions and diseases in combination with portable measurement devices.
- The system can control biological data or medical records as digital data because it is based on a personal computer. Thus, it will be able to be used in conjunction with electronic medical charts and online medical bill processing systems in the future.

Here is shown the use of P1. First, personal verification of a patient is done with a non-contact type IC-card "Felica" to avoid mixing-up patients. Secondly, high resolution video picture of the patient is taken to verify his state such as complexion, skin trauma, motion of joints and gait. The video is highly compressed and coded for preserving individual security and is sent to a medical doctor staying in his clinical office via the mobile network and the Internet in a real time fashion.

The proposed system targets the diagnosis of general chronic diseases such as circulatory disease, diabetes and respiratory organ disease. Therefore, in the system, not only the patient's video image but also various kinds of biological data can be measured with portable measurement devices such as the 12-lead ECG monitor, a blood-pressure meter, a blood sugar level meter and an ultrasonic diagnostic system. Most of these devices are connected directly to a main body of the Bag via general interface such as USB. The biological data is also sent to the doctor's computer after compression and encryption as well as the video image.

Experiments using P1

Experiments using P1 were performed at two clinics and one regional center hospital with three medical doctors and two nurses to test the validity of P1 under the assumption that a nurse visits a simulated patient's home for a medical care.

As a result of the experiment, it could be verified that video images transmitted by P1 were useful for checking the patient's state from the view point of the medical doctor. And the function of almost automatic transmission of biological data: ECG and blood pressure was highly evaluated by the nurses. However, they assessed that the setting procedure of the video camera and the connectivity of the main body of the Bag with the peripheral devices and the electrical power unit should be improved to be much simpler. In particular, it was found that setting and operation of the video camera may prevent the nurse from taking care of the patient and performing other usual medical tasks.

Improvements of the Electronic Doctor's Bag

In consideration with the evaluation results of P1, the Electronic Doctor's Bag has been reviewed. The device that the nurse carries has been improved mainly in its portability (Figure 22) and the unit that the doctor uses has been simplified because of the introduction of a central streaming server.

Improvements in the new system (P2) are as follows:

a) Personal authentication

A vein authentication tool is adopted in P2 instead of the IC-card which was adopted in P1. Such a biometric tool reduces risks of the loss of the card and mixing-up among patients.

b) Interface for transmitting the ECG data

ECG data is submitted to the main body of the Bag via Wireless LAN to enhance the operability. A mobile router for the Wireless LAN is incorporated in the Bag.

c) Video camera

A digital video camera used in P1 had high performance such as the function to avoid blurring of images due to hand movement but it was heavy and not easy to operate. In P2, a light weight and inexpensive web camera is adopted to improve the operability.

d) Ultrasonographic monitor

Some medical doctors who evaluated P1 pointed out that the portable ultrasonographic unit used in P1 did not have enough image resolution to check cardiovascular states of the patient. In response, a new portable ultrasonographic unit with high resolution is adopted in P2.

Figure 22: The second prototype (P2) of the Electronic Doctor's Bag



e) Central streaming server

In P1, the dedicated server “Digital Gate” which controlled communication between the Bag and the doctor’s PC had to be located in each clinic. On the other hand, in P2, this server has been replaced with a central streaming server located in a server center. This change enables plural doctors to receive the data of the same patient simultaneously anywhere and all over the world by accessing the central server via the Internet. Furthermore, this enables the doctors to refer and share the patients’ previous data.

f) Split-screen display

The video image from the ultrasonographic unit and that from the video camera are submitted to the central server and these two images can be displayed on one screen of the doctor’s PC. This function enables the doctor to check the position and the posture of an ultrasonic probe operated by the nurse while watching the echographic image.

In addition to the doctors who had evaluated P1, we asked another two doctors, who were working mainly in home visit medical services, to evaluate P2. As a result, most of the doctors gave a good evaluation on the basic function of the system, but required further improvements in the portability and operability to put it into practical use. And there was a problem that the proposed system was strongly affected by the quality of mobile communication network. This means that the streaming video of the patient can be broken up at worst when the Bag is connected to a busy network. For this reason, P2 should be used in consideration of a place and hours that affect the communication speed. In the future, the Bag should incorporate a technique of switching the mobile network to connect automatically and dynamically based on communication volume. And it is necessary to develop a database for patients to use, a system for cooperation among medical doctors and a link to the database of electronic medical charts.

On the other hand, the proposed system may be applied to some healthcare services other than home-visit medical service, i.e., healthcare rooms in schools or companies, mass examination, emergency care in ambulance cars and so on. In particular, if emergency medical technicians on ambulance cars can submit

high-definition video images of patients' body or their echographic images to doctors in a hospital, these data will be a very useful for procedures or treatments in the hospital.

2.4 Japan: Case 3: Mobile Support Tool for Doctors

2.4.1 Introduction

⁴EMR systems are becoming popular in medicine (A.L.Rector. 1996, Anderson JD. 1999, David W. Bates et al. 2003, Samuel J. Wang et al. 2003, Jim Johnson. 2010). This is because such systems enable doctors to manage mass medical data easily. As represented by POMR (Weed LL. 1968), medical record systems have been expected to support doctors' planning. However, most of these EMR systems are only capable of performing electronic data storage of legacy medical records. To help doctors analyze medical data that are generated over time, the system has to have the ability to present medical data that occur over various time spans. Because medical data often occur over various time spans, doctors have to study it over various time spans when performing a medical analysis. With current systems, doctors can look at medical data for only a few days at most. Accordingly, they cannot analyze medical data effectively. In addition, there is another problem that doctors do not have much time to use the EMR at their desks. As a result of these problems, doctors require a system that can support their cognition and medical analysis regardless of where they are. In view of these problems, we developed a brand new EMR system that supports doctors' understanding and medical analysis. This system has the features listed below:

- It has the ability to present medical data that occurs chronologically over various time spans.
- Its client application works on mobile devices such as a mobile phone or a tablet PC.
- In spite of the narrow bandwidth of wireless mobile networks, the system responds quickly.

In this paper, we introduce the conventional EMR systems in section 2 and explain their problems. In section 3, to solve these problems, we introduce the Mobile Timeline EMR System and its technological features.

2.4.2 Conventional EMR Systems

In this section, we introduce the conventional EMR systems. Typically, a conventional EMR system has a user interface similar to legacy medical records written on paper. Also, it displays the patients' SOAP information and the patient's information for one day. With these systems, by treating medical data as electronic data, doctors can search and manage their patients' medical data easily. This ability of mass data management is a significant advantage compared with legacy medical records. However, there are various kinds of medical data that are generated over various time spans. Thus, with these systems, which can make medical data available for only a few days, doctors cannot always look at it and infer the relationships that may exist among the various data. In other words, though doctors can look at and understand the state of patients who come for consultations two or three times with these systems, doctors are unable to examine and understand the state of patients who may have been suffering from certain conditions for years, such as asthmatics, diabetics or patients suffering from hypertension. Accordingly, these systems are unable to attain the purpose of supporting doctors' analysis and understanding.

2.4.3 Mobile Timeline EMR System

As described above, in order to meet the need to support doctors' understanding and medical analysis, the system must have a function to present medical data that are generated over various time spans and

⁴ Keisuke Ogawa, KDDI R&D Laboratories Inc., Tokai University, Graduate School of Medicine, Japan. See document [RGQ14.3.2-INF-0013](#)

allow doctors to look at medical data from any perspective. In order to solve this problem, we have introduced a timeline interface. The timeline interface has a multistage time scale including years, months and days. With a timeline interface, the system can present chronological data over various time spans.

In addition, in order to meet the demands for mobility and portability, we use a mobile device as a client of this system. By adopting a mobile device, the system gains a significant advantage in that doctors can analyze data anywhere. However, mobile devices have the problems listed below:

- Difficulty with input and reading using a small display.
- Low data transmission rate through a mobile wireless network.

To solve problem (1), we adopted an advanced word completion function using an optimized lexicon for each field of medicine.

For problem (2), we implemented the Adaptive Event Merge algorithm that reduces data transmission.

By means of the above, we can create a tool that is capable of supporting doctors' understanding and analysis wherever they are.

2.4.4 Timeline Interface

The timeline interface is the most important part of this system. With timeline interface, doctors can change the time scale to various time units. For example, doctors can change the unit time scale from hour to day or to month. By changing to a smaller time unit, doctors can observe medical data over a short time span in detail. Conversely, by changing to a longer time unit, doctors can look at medical data over a long time span. The length of the time unit can also be changed by pinch-in/pinch-out. The reasons why we use this interface are presented below:

There are various kinds of medical data. They occur over various time spans and they are interrelated in various ways.

If the different data are interrelated, the appropriate time scale for observation can be chosen. By selecting the appropriate time scale, the system can elucidate the relationships among the data.

For example, take the case where relationships can be discerned when data are observed over a long time span, where this would not be case if observation were to occur over a short time span. Conversely, there are other cases where relationships are not apparent when data are observed over an excessively long time span. Accordingly, the system must have a function that allows users to select the appropriate time scale.

With this timeline interface, doctors can change the time scale at will. Therefore, the various relationships between various data can be observed. In other words, doctors can examine medical data from various points of view.

In this manner, this system can serve not only as a tool for managing medical data, but can also support understanding and medical analysis.

Word completion using lexicon for medical data

The input method is not only an important factor that decides the usability of the system on mobile devices, but also a difficult problem. This is because mobile devices only have poor input accessories such as small touch panels and keyboards. In particular, in EMR systems, doctors have to input special characters for medical treatment using these poor input devices to write down the SOAP information or to search patients. To solve this problem, the word completion method using a lexicon of medical words is well known and effective (Laird S. Cermak et al 1992, C. G. Chute et al 1999, Hiroyuki Komatsu et al 2001). However, the words used in medicine differ significantly among the different fields. In other words, using the same lexicon for all the different areas of medicine would be limiting and inadequate. For example, the phrase 'nephrotic syndrome' is often used by paediatricians, but is rarely used by ophthalmologists. Accordingly, we have optimized the lexicon for each field of medicine. Simply put, we changed the bias of the TRIE (Donald R. Morrison 1968) structure of the lexicon for each field. Then for each field, by

summarizing and analyzing the most common inputs from doctors in a particular field, the system succeeded in improving the accuracy of word completion.

Adaptive event merge algorithm

The response speed of the system is a very important factor for deciding the system's usability. The advantage of the timeline interface is, as we described above, the ability to visualize the relationships among medical data by varying the time scales. If doctors want to look at data over a long period, they can expand the time scale as they wish. However, the system has to display a lot of data objects at once. On the other hand, in this system, since its client is a mobile device, the client only has narrow wireless communication bandwidth. In order to improve the response speed in this system, we implemented an Adaptive Event Merge algorithm. This algorithm is a function that merges neighbouring data objects adaptively.

When doctors expand the time scale, if the time gap of the neighbouring data objects is smaller than the threshold, the system merges the objects into one object. In this manner, the system can reduce the amount of data transmitted and improve the response speed and usability.

2.4.5 Conclusion

In this paper, we introduced an EMR system based on a new concept. This system has a significant advantage in that it is able to support doctors' understanding and medical analysis wherever they are. The system has the three features described below. With the timeline interface, doctors can look at and analyze medical data using various time scales. This is a significant help for doctors' understanding and analysis. Since its client is a mobile device, the system can support doctors wherever they are. In spite of using a mobile device as a client, the system can respond very quickly. In addition to the features described above, as the system is easy to use, there is a possibility that the doctors can use it as an educational tool.

References

- [1] A.L.Rector., 1996. Computer-based Patient Records, Yearbook of Medical Informatics, Section 2, 195-198.
- [2] Anderson J.D., 1999. Increasing the acceptance of clinical information systems. MD Computing 16(1)62-5.
- [3] David W. Bates, Mark Ebell, Edward Gotlieb, John Zapp, and H.C. Mullins., 2003. A Proposal for Electronic Medical Records in U.S. Primary Care, J Am Med Inform Assoc.
- [4] Samuel J. Wang, Blackford Middleton, Lisa A. Prosser, Christiana G. Bardon, Cynthia D. Spurr, Patricia J. Carchidi, Anne F. Kittlera, Robert C. Goldszer, David G. Fairchild, Andrew J. Sussman, Gilad J. Kuperman, David W. Bates, 2003. A cost-benefit analysis of electronic medical records in primary care. The American Journal of Medicine.
- [5] Jim Johnson, 2010. Making a Successful Transition to Electronic Medical Records. Healthcare Technology Online.
- [6] Weed LL., 1968. Medical records that guide and teach. New England Journal of Medicine 278:593-600.
- [7] Laird S. Cermak, Mieke Verfaellie, Marie Sweeney and Larry L. Jacoby, 1992. Fluency versus conscious recollection in the word completion performance of amnesic patients, Brain and Cognition Volume 20, Issue 2, Pages 367-377.
- [8] C. G. Chute, P. L. Elkin, D. D. Sherertz, and M. S. Tuttle, 1999. Desiderata for a clinical terminology server, Proc AMIA Symp.
- [9] Hiroyuki Komatsu, Akira Takabayashi, Toshiyuki Masui, 2001. Predictive Text Input with Japanese Dynamic Abbreviation Expansion Method "Nanashiki", WISS.

- [10] Donald R. Morrison, 1968. PATRICIA--Practical Algorithm to Retrieve Information Coded in Alphanumeric, jacm

2.5 Japan: Case 4 – The Network of Perinatal Telemedicine

2.5.1 Introduction

⁵Our company has developed and sells mainly electronic medical records for perinatal care and other health care systems since 2002. Company name of MITLA is derived from the Medical information technology laboratory. The history of research in the field of medical information is new in Japan. The history of the medical technology system in Kagawa prefecture has developed according to the Japanese governments agenda. I can tell that we have traced the history in the world of medical IT. We will focus on following four main topics, as a case of the perinatal telemedicine between Tono city and the centre hospital.

Here perinatal refers to the period before and after childbirth. According to ICD-10, the perinatal period which is defined as less than seven days after birth from 22 weeks gestation.

2.5.2 Background and Issues

The medical IT system being triggered by Kagawa prefecture is the project of the perinatal electronic medical records network in 1998. Recently Kagawa prefecture is known to K-mix that is the remote diagnostic imaging system. Various medical IT systems were created around the electronic medical records. MITLA has developed a perinatal electronic medical record named Hello Baby Program. The other hand, the number of obstetricians and gynecologists has decreased from 1984 to 2006. This has caused many problems to some regions of Japan. The most common is the Tono city. There are no obstetricians in Tono city, Iwate Prefecture. Pregnant women need a prenatal check-up once a month or more. For this to occur there was a medical centre built called Net Yurikago in 2007 (4 year ago). Here pregnant women can have regular checkups from midwives. If the patients have any worries or concerns she can talk to a doctor via the internet.

2.5.3 Telemedicine System Configuration

There are 2 servers used at the data centre. There is a pc and cell phone at the hospital and mid wives centre. At the maternity centre there also is a mobile CTG also used. MILTA monitors the system daily so that no problems occur. You can see here a picture of the mobile CTG Monitor (Figure 23 a). As you can see it's small and very light. I like you'd be surprised how easy it is to use. The data taken using the CGT which was sent to the doctor's cell phone and computer. The above graph shows the baby's heart rate and the graph below shows the mother's contractions in the display. For the while the doctor can access the patient's monitored data through the Hello Baby program (Figure 23 b). The midwife in the maternity centre meet pregnant woman and input checkup data to the Hello Baby program. Doctors can monitor the patient's data during the whole perinatal period (10 months).

⁵ Yhuko Ogata, MITLA Co., Japan. See document [RGQ14.3.2-INF-0014](#)

Figure 23: a) Mobile CTG monitor and b) Typical display of Hello Baby program

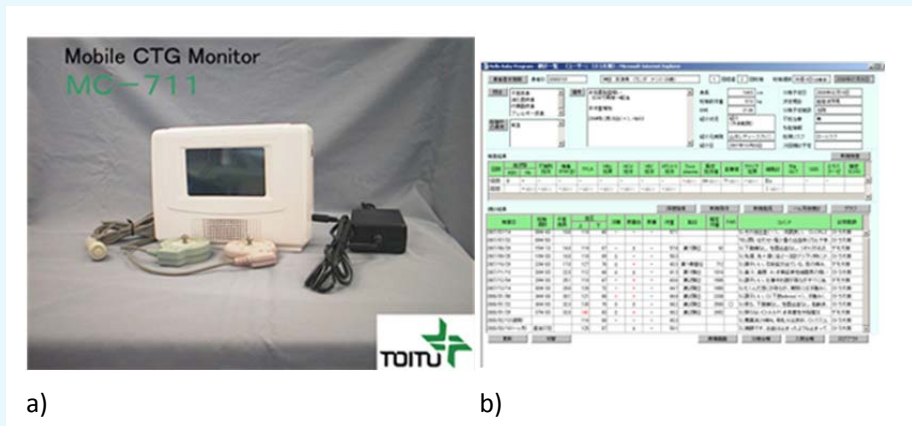

How to Operate the Telemedicine System

The patient uses the CTG system at home, which gathers the baby's heart rate and mothers contractions then this data is sent to the midwives, which is then sent to the hospital where the doctors can see the gathered data. This is very convenient because the midwife and doctor can both share the data. The doctor can see all the data at a touch of a button. This also caught the eye of doctors in America and there was an article written in the New York Times.

Figure 24: The network of perinatal telemedicine

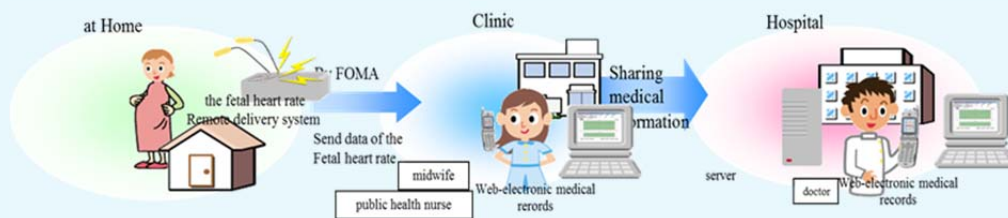

Application and Development

Babies who use this system will have their lives monitored to the end of life. In addition, Tono city staff members believe it is important to measure and confirm health data for all its citizens. This is an example of a child's case. The mother inputs the child's data once a week until the child graduates high. This slide shows the establishment of the telemedicine information network system. Before the patients had to travel far from rural towns to see a doctor but now they can now use telemedicine to communicate with from home.

Acknowledgement

We would express our thanks to Professor Hara Kazuhiro from Kagawa University, Ogasawara Toshihiro, Hospital Director of Ohfunato Prefectural Hospital in Iwate Prefecture and Tono city staff.

2.6 Japan: Case 5 – The Novel Mobile Telemedicine System for Real-time Transmission of 12-lead ECG Data and Live Video from Moving Ambulance to Hospital

2.6.1 Introduction

⁶In Japan, a telemedicine system utilizing a car phone was first made available in ambulances in the 1990s. The original analog car phone was later replaced with a digital mobile phone, enabling the transmission of 1- or 3-lead electrocardiogram (ECG) and heart rate (HR) data from the ambulance to the hospital. Consequently, a large number of ambulances in Japan were equipped with this telemedicine system.

However, despite the ready availability of the system, a large number of the devices were not used widely or effectively. One of the reasons for this was the presence of motion artifacts and other noise in the ECG data.

This mobile telemedicine system did, however, seem particularly applicable to emergency and disaster situations, where medical doctors wanted to use ambulances and temporary shelters as consultation rooms for the urgent diagnosis of heart disease. In the event of a disaster especially, it is necessary to diagnose victims in such settings over a period of several months since many victims fall ill due to stress.

Even though a large quantity of data was transmissible by the information communication technology (ICT) system developed, it was difficult for doctors in the hospital setting, separated from the patients, to reduce the frequency of misdiagnosis. In emergency and disaster medicine, misunderstanding the medical data provided can often make the situation graver.

The question then arose: Why could medical doctors not reduce the frequency of misdiagnosis? This was entirely due to the fact that the doctor and patient were in entirely different settings. The doctor expects to use stable data obtained in a static consultation room for diagnosis, but receives unstable data with motion artifacts and other noise under dynamic conditions in the ambulance or temporary shelter. Thus, it became necessary to find an effective solution that integrates the two different settings of the static hospital and the dynamic ambulance.

To this end, we realized the multi-functional electrocardiograph “Radarcirc”, which transmits the patient’s live image and vital signs, such as 12-lead ECG, the analyzed ECG data, blood pressure and oxygen saturation (SpO2) data, to the hospital in real-time [1]. The name “Radarcirc” is derived from the fact that the device can detect circulatory disease exactly as radar detects an airplane. The system enables the medical doctors in the hospital to remotely control the camera in the ambulance. The most important function of Radarcirc is that it makes the measurement and analysis of 12-lead ECG possible even in the case of severe motion artifacts and during cardiopulmonary resuscitation (CPR) [2].

In this study, the anti-artifact ability of Radarcirc was examined and the significance of Radarcirc for integrating the different medical settings is discussed.

2.6.2 Materials and Methods

12-Lead ECG, SpO2 and blood pressure were measured by the Radarcirc (Dainippon Sumitomo Pharma Co., Ltd.) and these data were transmitted by a mobile telemedicine system (Dainippon Sumitomo Pharma Co., Ltd. and NTT Comware Corp.) using a FOMA telephone (NTT DoCoMo, Inc.) (Figure 25).

The function of Radarcirc is based on adaptable filtering and weighted-mean technologies (Figure 26).

The artefact-resistant function of Radarcirc was examined using data simulation. The simulated sine waves were added to the lead-II waveform from the ECG checker (Nihon Kohden Corp.). The sine wave frequency was changed from 0 to 0.3 Hz and the sine wave voltage from 0 to 3.2 mV. Figure 27 shows an example ECG with 0.3 Hz noise and a 3.2 mv sine wave.

⁶ Masayuki Hashimoto, KDDI R&D Laboratories Inc., Japan. See document [RGQ14.3.2-INF-0016](#)

Moreover, a comparison was made of the automatic recognition by Radarcirc and manual recognition by 5 medical doctors of the points Pa, Pb, Pe, Qb, Stj, Ta, and Te for 30 beats in the following 20 files stored in the ECG database, QTDB: sel 100, 103, 4046, 16265, 16272, 16273, 16420, 16483, 16539, 16773, 16786, 16795, 17453, 230, 231, 32, 41, 803, 808 and 811. The representative values for the automated and manual recognition were calculated for each file by averaging the data for the 30 beats. The absolute values of the difference between the automated recognized point and the manually recognized point were analyzed statistically. Significant differences were evaluated using Dunnett's multiple-comparison test, with significance set at $P < 0.01$ or $P < 0.05$.

2.6.3 Results

The adaptive filtering and weighted-mean technology realized robust low-cut filtering without waveform distortion (Figs. 2 and 3). When the frequency change from 0 to 0.3 Hz and the voltage change from 0 to 1.5mV were added, the waveform distortion was less than 1% in every case (data not shown).

In the comparison of automated recognition with manual recognition by the 5 medical doctors, there were no significant differences between the two representative values for automation and manual recognition (Table 1).

2.6.4 Discussion

The electrocardiograph and the electrocardiograph monitor are different devices. The electrocardiograph with its weak filters and low resistance to noise is used for the exact diagnosis of heart disease because there is no distortion of the ECG. The electrocardiograph monitor with its strong filters and high resistance to noise produces a distorted ECG and thus is used only for the monitoring of the patient's condition. Radarcirc technology realizes both functions – the electrocardiograph and the electrocardiograph monitor—simultaneously, enabling Radarcirc to analyze ECG during CPR [2]. This function is based on the adaptive filtering and weighted-mean technology.

The Radarcirc technology incorporated in the new device we examined here was born from FLUCLET technology [3]-[4], which was developed as an analysis system of heart rate and blood pressure fluctuations in animal and clinical experiments [3]-[6] through independent pharmacological research at Dainippon Sumitomo Pharma Co., Ltd. Thus, Radarcirc makes it possible to monitor and analyze every beat of the patient's heart even in the event of sudden external shocks and vibrations or in the presence of motion artifacts.

As mentioned above, communication between multiple persons in different circumstances in different settings can often result in misunderstandings, especially in emergencies involving doctors in the hospital (static setting) and emergency medical technicians in the ambulance or temporary shelter (dynamic setting). We aimed to solve the problems resulting from this separation by considering two important points. First, it is necessary for the medical doctor in the hospital to ascertain the patient's status in the dynamic setting freely. Second, it is necessary to convert the dynamic 1- or 3-lead ECG data with motion artifacts or other noise into static and detailed 12-lead ECG data without noise and distortion so it can be effectively used by the doctor.

Figure 25: Real-time mobile telemedicine system



The breakthrough allowing us to address both these issues came in the form of progressing information technologies (IT) to advanced ICT. Advanced ICT meets the demands of practitioners to support communication and integrate information between different settings with practical meaning. In Japan, awareness of these issues was sparked by Kitaro Nishida in philosophical fields and are discussed and applied by Hiroshi Shimizu in scientific fields [7]. The integration of the different circumstances and settings is expressed in Japanese as the integration of “Ba”, a technical term that is now in frequent use worldwide.

The use of high-speed data communication alone is not sufficient to realize the integration of different “Ba” (i.e., the different circumstances and settings). Advanced ICT, however, seeks to employ an intelligence to integrate them. The integration of the different “Ba” by the combined technology of Radarcirc and the mobile telemedicine system provides a good example for the development of other advanced ICT systems in the future.

12-Lead ECG, SPO2, and blood pressure data are transmitted in real time by a FOMA mobile phone to the hospital servers via the internet.

Figure 26: Adaptive filter and weighted mean

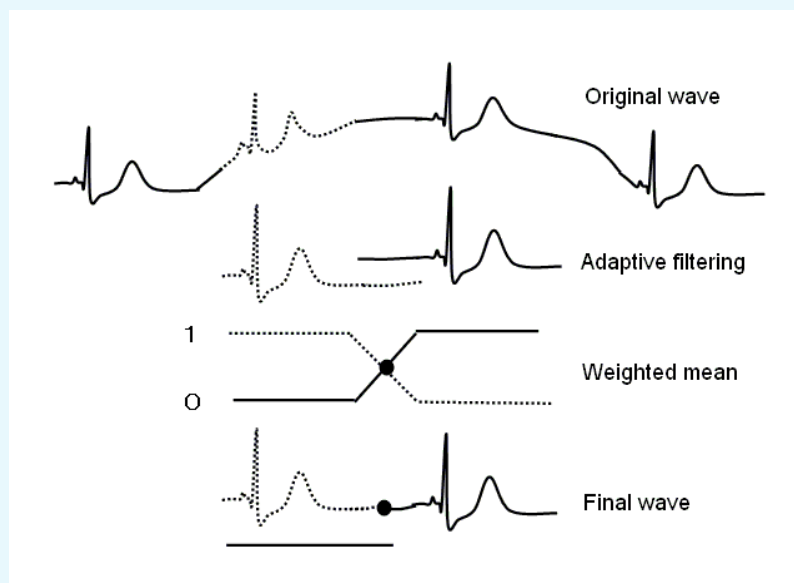

An adaptive filter is used for each heartbeat. Each filtered ECG signal is connected smoothly at the point by the weighted mean method. For the final ECG signal, the ECG wave with a broken line is distorted compared to the other ECG waves.

Figure 27: Effects of adaptive filter and weighted mean for artificial noise

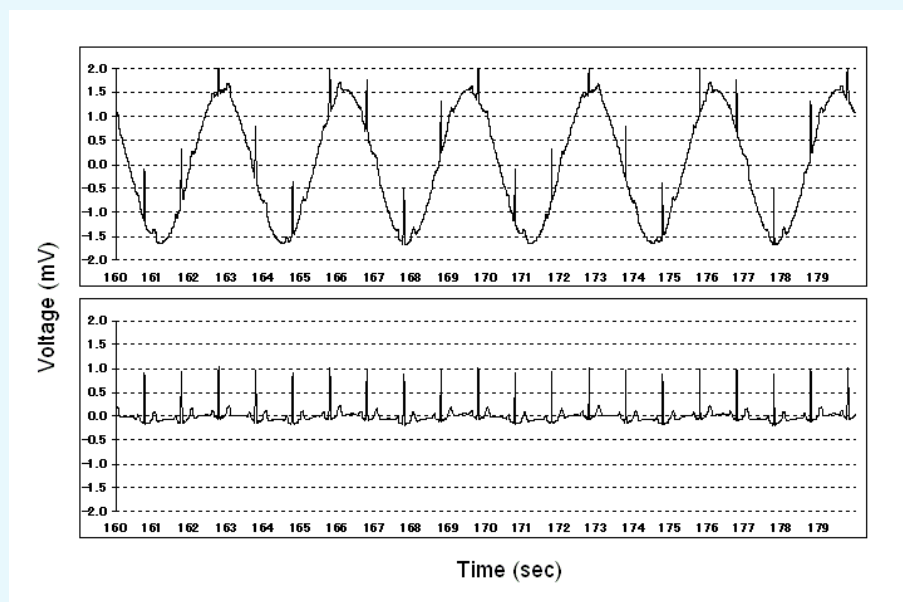

Upper panel shows ECG with artificial sine noise. The amplitude and frequency of the noise is 1.5 mV and 0.3 Hz, respectively. Bottom panel shows ECG after filtering by Radarcirc.

Table 1: Difference between automated and manual recognition for points in ECG database files

Recognized point of ECG	Pb	Pa	Pe	Qb	Stj	Ta	TE
Mean	2.2	1.8	4.7	2.5	0.2	1.3	0.9
S.E.	1.5	0.9	1.7	1.1	1.0	1.2	2.1
Statistical difference	N.S.	N.S.	N.S.	N.S.	N.S.	N.S.	N.S.

At each recognized point, the absolute values of the difference between the automated recognized point and the manually recognized point were analyzed statistically (n=20).

References

- [1] Y. Otsuka, H. Yokoyama, and H. Nonogi, "Novel mobile telemedicine system for real-time transmission of out-of-hospital ECG data for ST-elevation myocardial infarction," [Catheterization and Cardiovascular Interventions](#) vol. 74(6), 2010, pp. 867–872.
- [2] G. Shimpuku, N. Morimura, T. Sakamoto, T. Isshiki, S. Nagata, and T. Goto, "Diagnostic performance of a new multifunctional electrocardiograph (Radarcirc™) during uninterrupted chest compressions in cardiac arrest patients," *Circulation Journal*, to be published.
- [3] R. Nagai, and S. Nagata, "New algorithms for real-time, 24 hr continuous and noise-adjusted power spectral analysis of heart rate and blood pressure fluctuations in conscious rats," *Jpn. J. Pharmacol.* Vol. 72, 1996, pp. 335–364.

- [4] R. Nagai, S. Nagata, F. Fukuya, J. Higaki, H. Rakugi, and T. Ogihara, "Changes in autonomic activity and baroreflex sensitivity with the hypertension process and age in rats," *Clinical and Experimental Pharmacol. and Physiol.*, vol. 30, 2003, pp. 419-425.
- [5] M. Suzuki, S. Hori, I. Nakamura, S. Nagata, Y. Tomita, and N. Aikawa, "Role of vagal control in vasovagal syncope," *Pace*, vol. 26, 2003, pp. 571–578.
- [6] Y. Makiguchi, S. Nagata, T. Kojima, M. Ichimura, Y. Konno, H. Murata, and H. Ueda, "Cardiac arrest during gamete release in chum salmon regulated by the parasympathetic nerve system," *PLoS ONE*, vol. 4(6), June 2009, e5993.
- [7] H. Shimizu, "'Ba-Principle': new logic for the real-time emergence of information," *Holonics*, vol. 5(1), Aug.1995, pp. 67–79.

2.7 Japan: Case 6 – Telemetry for Wild Birds and Future Technical Expectations to Prevent Avian Influenza

2.7.1 History

⁷The ITU-D Study Group 2 Question 14 Rapporteur's Meeting for Telemedicine, hosted by the Ministry of Internal Affairs and Communications of Japan, was held at the Kokusai Bunka Kaikan in Tokyo on July 3–4, 2008. This meeting featured active discussions on the Statement of Appeal on an Integrated Information and Communications Network for Avian Influenza (commonly known as the Statement of Appeal on Avian Influenza), which was finally adopted after incorporating a wide range of suggestions and after repeated revisions and input, at the ITU-D Study Group 2 meeting in September of 2008.

The following actions relate to the application of telecommunication technologies to prevent and contain avian influenza, and for adoption and implementation of these actions under the Statement of Appeal on Avian Influenza.

Summary of the Statement of Appeal on Avian Influenza (ITU-D Study Group 2 Question 14 Rapporteur's Meeting, Tokyo, July 2008).

2.7.2 Principle of Information Disclosure

Any governments and individuals involved must disclose information on avian influenza infection immediately upon its discovery.

2.7.3 Tracking Technologies

We ask ITU and associated governments and corporations to seek to develop technologies to track bird migrations, including nano telemetric devices, short- and long-distance RFID, data collection satellite systems, and so forth.

- Securing Radio Frequencies

The following tasks will be assigned during the implementation of tracking technologies:

- ITU-R: Priority utilization of frequency bands.
- ITU-T: Standardization of technologies.
- ITU-D: Provision of know-how free of charge to developing countries.

⁷ Masayuki Hashimoto, KDDI R&D Laboratories Inc., Japan. See document [RGQ14.3.2-INF-0015](#)

2.7.4 Integrated Information Network

ITU will work with WHO to create the Information and Communications Network for Avian Influenza, disseminating, to various nations, telecommunication technologies to prevent and contain outbreaks.

2.7.5 International Organizations

The relevant international organizations should work together with ITU to integrate various advanced ICT networks to prevent avian influenza outbreaks and to call on individual governments for participation in the network.

2.7.6 Establishment of Human Resource Training Programs

International organizations and governmental aid agencies are encouraged to provide educational materials, knowledge, and invitational programs to train specialists in related fields (telemedicine, especially for avian influenza tracking, information networks, etc.) in developing countries.

2.7.7 About Avian Influenza

Outbreaks of avian influenza caused by widespread transmission between birds, animals, and humans are believed to have inflicted a grave human toll from time to time, starting in ancient times.

The genes of the avian influenza virus are known to mutate rapidly, creating an obstacle to preventive strategies by hindering prompt identification of the respective antibodies for the antigen and vaccine preparation. Some researchers predict avian influenza may result in death rates of 50% in developing countries and 10% even in developed countries – alarmingly high compared to SARS, which recorded a death rate of 4%. The influenza viruses that cause epidemics today were once highly fatal to humans; however, their pathogenicity has decreased over time. Generally, mutations occurring in viruses found in carrier birds (geese, duck, sea swallows, etc.) during bird-to-bird transmission increase pathogenicity, producing new strains of avian influenza. The body temperature of the birds involved is considered to be one of the parameters affecting the process. The consensus view among experts is that it is simply a matter of time until bird-to-human transmission occurs from migratory birds carrying high-pathogenicity viruses. In nature, deaths among wild birds go unnoticed by human observation, and a major cause of such deaths may be the influenza virus.

Despite the importance of epidemiological monitoring in these biomes, no system has been established for real-time monitoring of avian influenza on a global scale. Such efforts would most likely fall under the jurisdiction of WHO, but since they would require the development of new technologies and since the regulation of frequencies and standardization of technologies is primarily the duty of the ITU, cooperation between the two organizations is crucial.

2.7.8 Present Satellite Technology

ARGOS system (DCS)

Theme: The maximum weight of instruments that can be carried by wild birds is 4% of their body weight. This places significant constraints on antenna size and transmitter power source. The basic technologies used in the first-generation ARGOS system date from the 1960s and were designed for data collection from ocean buoys. Despite efforts to improve transmission rates to broadband levels for 3rd-generation transponders, the G/T (gain/temperature, -18dB/K) of receiving antennas remains inadequate. The ARGOS terminal's lifetime will be only a few months due to battery consumption. Therefore, the ARGOS terminal on the back carry harness shall be glued on the feathers. The heavy weight of the payload can cause birds to crash.

2.7.9 Expected Technology

- Long distance RFID (built-in battery type)

The operational life of a built-in battery type RFID is directly proportional to the size of the battery (including solar cells). The device will be larger and heavier than a battery less counterpart. Long-distance RFID systems on 2.4GHz find their ideal application with medium to large migratory birds that do not collect near specific feeding areas. The only method currently available for collecting ID data is to deploy an observer equipped with a ground unit. In theory, it should be possible to perform unmanned observations by installing a unit that scans the sky, like a radar unit, at lighthouses and breakwaters along migratory routes. However, such systems remain in the planning stages, and numerous technical issues remain to be resolved.

These systems operate on frequencies within the ISM (industrial, scientific, and medical) bands. One possible choice given the propagation distance required (300–500 m) is the microwave range. The high efficiency required for the power source could be achieved via an electric double-layer capacitor (EDLC), which physically adsorbs ions within the battery electrolyte to the surface of the activated carbon electrodes in the charge cycle, then desorbs them in the discharge cycle. Unlike other capacitors, the EDLC electrical accumulation device is not based on chemical reactions. Given the extreme light weight of EDLCs, combined use with micro solar cell units may lead to long-distance RFIDs with semi-permanent operating lives. In any event, actual implementation of long-distance RFID must await further progress in R&D in the related technologies.

- LEO with advanced DCS

We would like to propose the next generation digital transponder that is an advanced DCS with multibeam on S-band to perform the on-board processing (DCS and navigation system with Doppler shift). In the case of 38dBi antenna of the spacecraft, the ground terminal with 10dBm RF-output and –10dBi antenna can transmit up to 400 bps with BPSK. This terminal attached to the leg of a bird will be suitable for a dove or a gull in size. Comparison of the ARGOS system and proposed system, 2000 times of processing speeds are necessary at the baseband level of space craft.

However, advances in the processing speed of FPGA (Field Programmable Gate Array) that can be mounted should make the required processing possible. The near-future theme for study is the development of a mounted device that can calculate the Doppler shift by the least-squares method by base-band processing per beam area. Should unused payload space remain in low-orbiting satellites scheduled for launch, we encourage space development agencies to consider including advanced DCS (next-generation digital transponders).

- Geographical Information System (GIS)

It should be possible to visually grasp the approach of suspected carriers by compiling a species-by-species distribution map of migratory birds. For example, in the month of March, few migratory birds fly along the parallel from the Korean peninsula across the Sea of Japan, but two groups of yellowlegs that consistently migrate from Vietnam to Siberia have been confirmed: 1) a group passing through the Korean peninsula; 2) a group passing through the Japanese archipelago. If the DNA types of the virus collected from the dead bodies of affected wild birds (Whooper swan) in Korea and Japan are found to be identical, the avifauna would suggest the possibility that yellowlegs are carriers. Based on independent component analysis, n number of data sources can be estimated from n number of independent observation sites based on higher-order statistics. Comprised of the geographical distribution of migratory birds, virus identification and virus geographical distribution, and the geographical distribution of patients, the GIS should serve as an effective support system for epidemiological risk forecasting. We should be able to achieve the highest cost-benefit performance in preventive effects for the available medical budget by concentrating efforts on distributing antiseptics, vaccines, and medication to regions where suspect migratory birds are known to have arrived.

2.8 Japan: Case 7 – ViewSend Internet Communication Technology

2.8.1 Introduction

⁸ViewSend Co., Ltd. was founded in October 2000 as a software development and systems integration company. ViewSend’s objective was to develop videoconferencing software that would exceed the highest industry standards and to integrate that software into a more affordable, user-friendly, PC-based multimedia videoconferencing system. In June of 2004, ViewSend purchased all assets of KLT Telecom, Inc. a well-known American company committed to telemedicine, tele-radiology, and videoconferencing challenges. ViewSend Server/RAD, ViewSend Online and ViewSend ReportSystem, the main products of ViewSend, were widely applied to the medicine area. The customers of ViewSend were in the United States, Japan, China and Indonesia.

ViewSend RAD provides a real-time 3-in-1 teled solution for telemedicine, tele-radiology, and videoconferencing. This product is designed to be a real-time software solution – collaboration, consultation, or training.

ViewSend Online is a web-based videoconferencing system developed by ViewSend in 2007. It is an Internet service and provides telemedicine, tele-radiology, videoconferencing and document sharing.

ViewSend Report System, a sub-system of ViewSend RAD, is non-real time software for tele-radiology. The report management and report format customization is available and enhanced in this software.

VIEWSEND Internet Communication Technology

- ViewSend RAD

Figure 28: ViewSend RAD

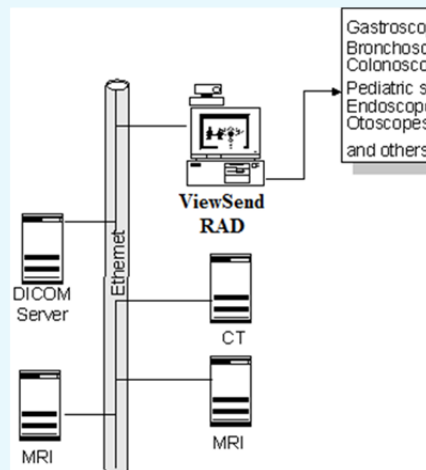

ViewSend RAD understands that the radiology workflow must be optimized for reading studies. There is no time to waste on DICOM querying, retrieving, historical information gathering. ViewSend RAD automatically pre-retrieves, organizes, and presents the data you will most often need.

⁸ Kenei Shie, Guoliang Wang, Yang Yang, ViewSend ICT Co., Ltd., Tokyo Japan. See document [RGQ14.3.2-INF-0017](#)

Tele-radiology

ViewSend RAD is designed to be a fast, cost-effective way to retrieve your medical images/data and transmit them to remote locations. Whether the source image originates from a DICOM 3.0 modality, DICOM server, film, or medical device ViewSend RAD can prepare the series within a study and then transmit to the remote destination (Figure 28):

Telemedicine

Figure 29: ViewSend telemedicine

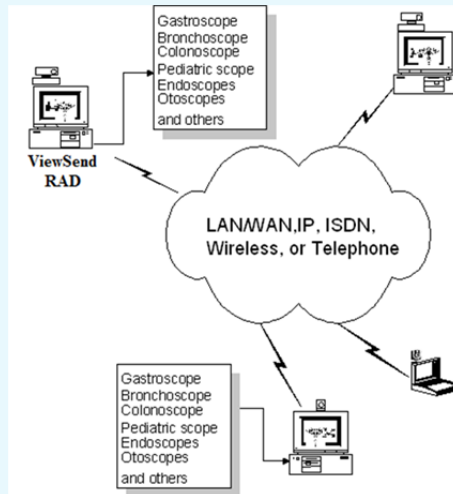

ViewSend RAD helps doctors increase the delivery quality of their care. Medical scoping devices can be connected to ViewSend systems through industry standard S-video or composite inputs. Digital images or video clips can be captured and transmitted in real-time to the specialist. Live video feeds can be used to enhance remote training, teaching, or telesurgery (Figure 29).

- Videoconferencing

Figure 30: ViewSend videoconferencing

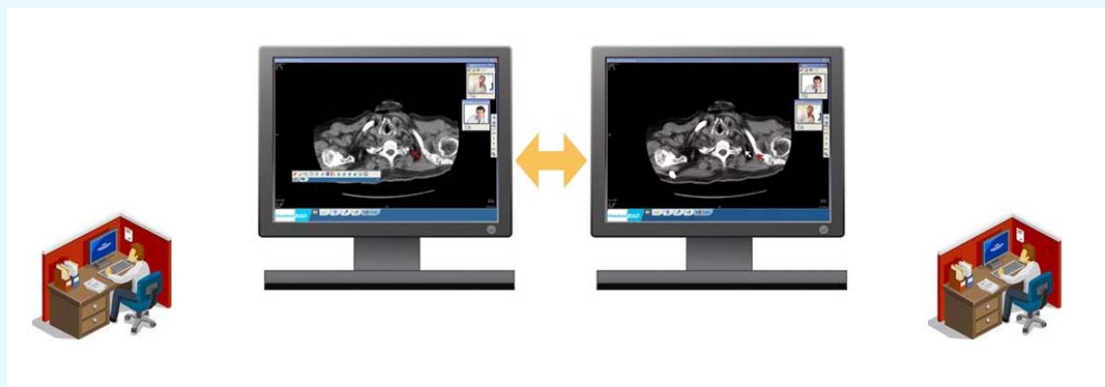

Rounding out the unique 3-in-1 solution, ViewSend leads the industry by providing business quality videoconferencing. Whether over ISDN (H.320) or IP (H.323), ViewSend provides a full featured video capable software solution for point to point or multipoint conferencing. Consults, second opinions, live

video feeds, CME, training, teaching or telesurgery are all enhanced by integrated videoconferencing (Figure 30).

- ViewSend Online

Dicom image data are uploaded to ViewSend Online Server by ViewSend RAD to share with all users in the same group. The users login to the ViewSend Online Server by username and password to access these images. By the web service, the users can access the server by all terminal devices which support the web browser. This makes home healthcare possible (Figure 31).

Figure 31: ViewSend Online

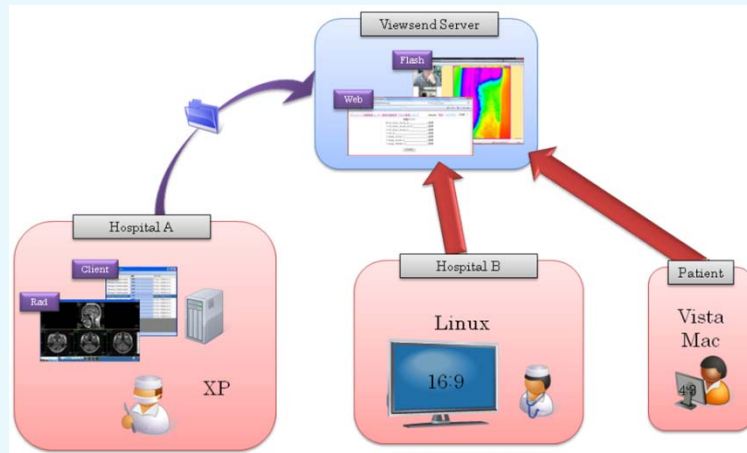

- ViewSend Report System

ViewSend Report System is a sub-system to enhance tele-radiology by the customization of report management and report format (Figure 32).

The requirement of report management differs between hospitals. The management project, work list and report format of ViewSend Report System can be modified by the XML files for the users. The medical image data and medical records can be transmitted to the Service Provider, and the report with key image can be reply to the Service Recipient as shown in Figure 32.

Figure 32: ViewSend Report System

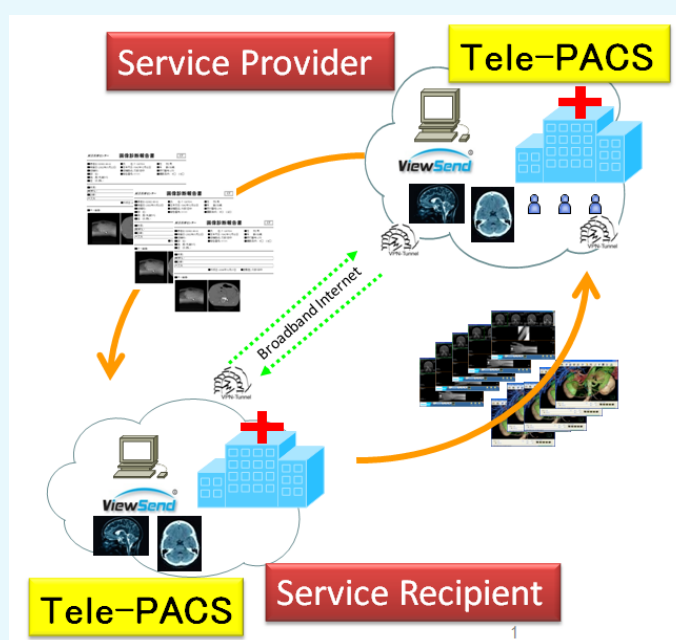

- Application examples

Tone Numata telemedicine network (TN-2).

There is a good example of viewsend internet communication technology at Tone Numata. In the case of emergency, video conference consultation is used and it is habitually used for medical image sharing.

2.9 Japan: Case 8 – Remote and Mobile Healthcare ICT Trials in Japan

2.9.1 Introduction

⁹In most countries, the number of elderly people is increasing recent years. Especially, Japan has faced super-ageing society. An aging society needs much higher medical cost, and it has been increasing year by year. At the same time, the number of patients suffering from life style-related diseases such as diabetes is also increasing, which is another factor to increase medical expenditure.

It is very important and is a common global challenge to support elderly people's healthcare from the view point of the Quality of Life. To solve those issues, Japanese government announced a policy to use ICT effectively, and has been putting the model projects into practice and collecting evidences in order to promote remote health care services.

In this contribution, three trial services related to remote and mobile healthcare by using ICT are introduced as examples examined in Japanese model projects. Then, this contribution proposes potential standardization items regarding remote and mobile healthcare ICT by taking account lessons from Japanese healthcare ICT trials led by Ministry of Internal Affairs and Communications (MIC), Japan.

⁹ Ms Mayumi Yamauchi, Ministry of Internal Affairs and Communications, Japan and Mr Hideo Imanaka, NTT, Japan. See document [2/207](#)

2.9.2 Country Overview

According to recent research results, the number of senior citizens in Japan, aged over 65 years old, is 23.1%, and 20% of households are elderly people living alone in 2011. An aging society needs much higher medical cost, and in practice, the total health expenditure reached 460 billion US dollars in 2010, which has been increasing year by year. Accordingly, Japan becomes the first nation in the world facing with difficult challenges caused by super-aging society.

Such a situation happens not only in Japan, but also in other countries. In some researches, the elderly ratio of Asian countries such as South Korea and Singapore follows Japan 10 years behind. In other Asian countries, speed of super ageing is more rapid than Japan. For example, the elderly ratio will reach 20% in China and India soon. This brings tremendous number of aged people, around 5 billion, which is 4 times larger than the current total population in Japan.

2.9.3 Objectives and Strategies

Objectives: to reduce medical cost and to improve Quality of Life

Strategies: to exploit remote and mobile healthcare by using ICT

1 Activities Implemented

Three cases of remote healthcare ICT and mobile healthcare ICT are introduced as the trials in Japan.

- a) Remote healthcare for monitoring after discharging, an MIC model project.
 - Purpose: to provide healthcare service for Homecare Patients after discharging from hospital.
 - Service: A Homecare patient is monitored its vital data such as blood pressure, heart rate and pulse by a doctor who is in the hospital. Doctors and nurses visit patient on a regular basis, for example once or twice a week, to provide adequate medical treatment based on the knowledge as to how the patients have been between their visits.
- b) Remote healthcare promotion for elderly, an MIC model project.
 - Purpose: to promote healthcare for elderly people especially in rural area.
 - Service: It shares vital data of elderly people with doctors and public health nurses, and provide remote consultation over video phone. Doctors in the city and public health nurses and elderly people in the local area share healthcare related data. Elderly people visits a community center regularly to have their physical condition checked by public health nurses and to consult with doctors in the hospital. Public health nurses will assist elderly people to use devices and internet.
- c) Mobile healthcare for Post Disaster, in Fukushima after the great East-Japan earthquake.
 - Purpose: to provide medical services in shelters after disaster.
 - Service: After the disaster, evacuees who lost their houses and stayed in shelters for long time needed medical services, and many medical professionals came to the disaster struck area to response to evacuee's need. In order to allow for common use of medical records by these medical professionals, medical record sharing system was offered to Fukushima Prefectural University Hospital Medical team.

2 Technologies and Solutions Deployed

- a) Remote healthcare for monitoring after discharging, an MIC model project.
 - Remote data monitoring service using vital sensors:
 - Remote consultations with doctors over video phone.

- HPKI for user authentication.
- Continua Health Alliance based video phone and vital sensors.
- b) Remote healthcare promotion for elderly, an MIC model project:
 - HPKI for user authentication.
 - Continua Health Alliance based video phone and vital sensors.
- c) Mobile healthcare for Post Disaster, in Fukushima after the great East-Japan earthquake:
 - On Demand VPN service for secure network over the Internet.
 - HL7 based healthcare data.

3 Changes and Outcomes Achieved

- a) Remote healthcare for monitoring after discharging, an MIC model project:
 - It reduces patients' physical burden to visit hospital regularly.
 - It is possible to receive patient's data and to diagnose immediately, that would enable doctors to detect diseases earlier.
 - Patient and their family feel safe since they can consult with medical professionals whenever they want.
- b) Remote healthcare promotion for elderly, an MIC model project:
 - The number of people who has disease from 6 to 1. That means 83% of improvement was achieved by this service.
 - Some local governments continue to use this service after the model project has finished.
- c) Mobile healthcare for Post Disaster, in Fukushima after the great East-Japan earthquake:
 - What they need most was checking the patient's past medical records on site.
 - Patients' medical record should be protected as much as possible even at the emergency.

4 Challenges and Success Factors

Challenges: Changing the way of doctors work.

Success Factors: Collaboration with medical doctors and their understanding to use of ICT.

5 Lessons Learned and Next Steps

Remote Healthcare and Remote Health promotion are relatively easy to start-up in technical sense. People are able to send their vital data and receive advice from doctors at any time and any place. They are also able to be consulted by doctors when they need. Doctors can check patients' condition with their own eyes through TV phone. If all devices are based on global standards, healthcare ICT will be easy to start-up and will be cost effective. Remote healthcare ICT and mobile healthcare ICT are really effective to provide better healthcare service outside hospitals.

The next step of healthcare ICT is to discuss standardization of security and interoperability with healthcare devices. The trials mentioned in this contribution adopted "on demand VPN" service for ensuring security and privacy, and specification of "Continua Health Alliance" for communicating vital data between health devices and servers in telecommunication networks. In conclusion, it is needed to discuss the standardization in ITU considering of unique colors and real-time capability in medical services continuously.

2.10 Report of ITU Workshop on e-Health Services in Low-resource Settings in Japan

2.10.1 Introduction

¹⁰In developed countries including Japan, the aging society problem is causing a chronic shortage of doctors. Meanwhile, developing countries also have a chronic shortage of doctors but for a different reason, namely the limited availability of medical services.

Tele-medicine and e-Health are being studied as one solution for these problems, and ITU-T SG16 and ITU-D SG2 study standardizations on e-Health technologies and deploy it widely in developing countries. In November 2012, the ITU and WHO launched a partnership called the m-Health initiative, which aims to use mobile phones to deliver e-Health services to combat non-infectious illnesses. Since April 2012, the ITU-T focus group on machine-to-machine (M2M) service layer called FG-M2M has been studying the standardization of e-Health as an M2M application.

With the aim of ensuring that e-Health standardization proceeds smoothly in the future, the ITU-D and ITU-T held a joint e-Health workshop to provide a place for dialogue and the exchange of information between each of their members. In this way, it was expected to clarify the special requirements of developing countries, and to specify the items for future standardization towards the implementation of e-Health using advanced technology.

This contribution covers brief results of the workshop, and proposes future activities for progressing towards the standardization work and deployment in developing countries on e-Health services.

Photo 1: Opening speech from Vice- Minister of Japan



2.10.2 Overview of the Workshop

Opening speeches were made by Mr Eiichi Tanaka, vice-Minister for Policy Coordination in Ministry of Internal Affairs and Communications, MIC, Japan (Photo 1), and by Mr Sameer Sharma of the ITU Asia-Pacific regional office on behalf of the ITU Secretary-General. These were followed by keynote speeches from Mr Tetsushi Sakamoto, the State Secretary for MIC, Japan, on the subject of Japan's e-Health policies, and Prof. Kiyoshi Kurokawa of the National Graduate Institute for Policy Studies, who gave a presentation under the title of "Global Agenda in Post Fukushima" in which he raised issues that should be addressed not just by Japan but by the whole world in the wake of the Great East Japan Earthquake. Mr Mark Landry

¹⁰ See document [RGQ14.3.2-C-0024](#)

of Pacific regional office of World Health Organization, WHO, gave a speech on behalf of WHO in which he described some examples of e-Health policies across Asia, and the current status of cooperation with WHO (Photo 2).

Photo 2: Workshop



2.10.3 Requirements for Low-resource Settings

On the theme of implementing e-Health with low-resources, representatives from India, Sudan, Uganda, Algeria, the United Arab Emirates, Bangladesh, Vietnam and Myanmar gave presentations on the current situation of e-Health in each country, the issues that need to be addressed, and requirements in each case. The requirements of developing countries are characterized by delayed development of infrastructure, not only for medical care but also for insurance, sanitation and health management, and a shortage of healthcare workers coupled to a poor educational environment. Instead of the advanced e-Health systems that are being considered in developed countries, these presentations introduced solutions such as Web-based sharing and education of medical information, using video conferencing to facilitate collaboration between medical workers including doctors, and using mobile phones for medical consultation (m-Health), whereby e-Health is expected to provide a broad range of benefits.

Photo 3: Demonstrations on m-Health



Easy and convenient health service using instruments certified by Continua Health Alliance

mHealth System

Based on Continua Design Guidelines

To provide easy and convenient health data management, we introduce a mobile health (mHealth) system based on Continua Design Guidelines which is an industry standard for interoperable electronic health data. Our system enables easy data upload and simple data transfer which contribute to long-term health data storage, so that it supports more flexible service creation.

Features

- Comply with Continua WAN-IF; uploading data through data terminal equipments is available.
- Comply with Continua HRN-IF; exchanging data among health services is available.
- Use a smart phone as a gateway for data upload and a device to identify the person by ID cards.

Application Scenarios

- Support daily health management of weight, blood pressure and pedometer data.
- Ensure continued medical service and health care in disaster areas.
- Provide health check services in developing countries facing deficient in medical resources.

NTT Group Advantages

NTT is delivering attractive health ICT services so as to improve quality of health-care, exploiting its practical experience in doing experiments and businesses.

NTT

Copyright © 2013 NTT. All Rights Reserved.

2.10.4 Items for Standardization

Representatives from Japan, South Korea, Singapore, and the United States introduced some advanced examples of e-Health initiatives, and discussed the challenges of implementing e-Health. NTT Data gave a

presentation introducing cases of Personal Health Record, called PHR, management and monitoring as examples of m-Health services in Japan, and stressed the importance of security and privacy protection. The representative from Singapore introduced a Smart TV health management system based on ITU standards, and showed that interactive e-Health using TV sets and remote control devices may be suitable for an aging society since these devices can be easily used even by elderly people. Also, the US representative introduced the importance of considering e-Health for people with disabilities; NICT introduced the possibility of a body area network (BAN) that people can wear in order to connect to healthcare equipment; and Fujitsu introduced the possibility of a heart simulator that aims to improve healthcare technology. These presentations highlighted the need for standardization of the data structures and protocols required for the transmission of PHR and other data, of the application interfaces and transmission methods used between medical/healthcare devices and telecommunication networks, wireless devices and fixed devices, and of security, which is essential when exchanging PHR data.

2.10.5 e-Health in the Event of Disaster

Experiences from the Great East Japan Earthquake with regard to the use of e-Health in disaster situations were introduced. A&D made a presentation about a monitoring system for information such as blood pressure for health management of people affected by disasters, which was actually put to use after the Great East Japan Earthquake. Professor Isao Nakajima of Tokai University – the vice rapporteur of ITU-D Q14/2 and co-chairman of this workshop – described items that need to be studied in e-Health and radiation related disasters in relation to the nuclear power plant incident. These presentations demonstrated the usefulness of e-Health in the event of disaster, and made a case for the importance of preserving two-way communications.

2.10.6 Future Direction for ITU Work

Mr. Masahito Kawamori of NTT - the rapporteur of ITU-T Q28/16 and co-chairman of this workshop, drew up the following summary of the results of the workshop and the future direction of e-Health standardization at the ITU.

- To promote the spread of e-Health, it is important to provide education in order to eliminate misconceptions about the circumstances of developing countries.
- From the viewpoint of standardization, to establish cooperation between requirements, terminology definitions, data sets/applications, and related organizations.
- In particular, to make a terminology database, since the technical terminology relating to e-Health covers many fields including medicine, healthcare and ICT.
- For e-Health related regions, to study the application of this technology as related to the elderly, stranded people, and disabled people.
- In the future, to supply information to the ITU website including the content of speeches given at this workshop, and to hold an enlightenment event in cooperation with WHO.

2.10.7 Other Related Events

Alongside the workshop, there were also demonstrations from NTT Laboratories related to m-Health (photo 3). A simple health management system was introduced where healthcare equipment including blood pressure gauges and SMS text messaging is used to implement m-Health with low initial investment. In this exhibition, it was found that there are many different opinions regarding this technology.

2.10.8 Conclusion

Over 130 persons from 20 countries attended this workshop (photo 4), since e-Health has been globally recognized as important by developing and developed countries alike. It is expected that this field will continue to grow in the future. For its efficient global development, international standards, with

appropriate consideration of the regional characteristics and environmental conditions of each country, are essential.

This contribution proposes to continue dialogue between ITU-T and ITU-D members by using workshop since this kind of workshop is expected to contribute to the expansion of developing countries, which is the scope of ITU-D, as well as the further development of ICT standardization, which is the scope of ITU-T. Furthermore, this contribution also proposes to collaborate with WHO for deployment m-Health solutions to developing countries, along with an MoU signed by ITU and WHO.

To access presentations delivered at the workshop, please visit: <http://www.itu.int/en/ITU-T/Workshops-and-Seminars/e-Health/201302/Pages/default.aspx>

Photo 4: Demonstrations



2.11 Korea (Rep. of): Case of SK Telecom – SNUH (Seoul National University Hospital) HealthConnect Services

2.11.1 Introduction

¹¹Since healthcare costs are rising dramatically due to the aging of population, it can possibly become a huge national burden without a proper preparation. The official launch of HealthConnect marks a good starting point that will lead to the development of a future convergence healthcare technology and innovative medical services. Looking ahead, SK Telecom (incumbent private telecommunication operator) and SNUH (Korea's first national hospital) will work together to research and develop future healthcare models so as to offer the most reliable medical services for the next-generation, increase healthcare consumer satisfaction, and strengthen Korea's national competitiveness in healthcare.

In this case study, information on the joint venture firm between SK Telecom and Seoul National University Hospital is shared.

¹¹ Contribution: Lim Hyoung-Do, SK Telecom, Korea (Rep. of). See document [2/175](#)

2.11.2 Stakeholders

The name “HealthConnect” represents convergence between core capabilities of the two companies: SK Telecom’s strength in ICT and network operation and SNUH’s expertise in medical technology. SK Telecom and SNUH signed a strategic partnership agreement in April 2011 to share their capabilities in healthcare ICT business, to identify specific areas of cooperation, and to develop innovative joint business models by devise measures. After signing the joint venture agreement in October 2011, SK Telecom and SNUH have completed creating the organizational structure such as business, technology, strategy, and new business development of the joint venture firm and recruited necessary employees in just three months. The joint venture is established with a capital of KRW 20 billion or USD 17.6 million. SK Telecom holds 49.5 percent of the stake in the joint venture, while SNUH holds the remaining 50.5 percent.

2.11.3 Main Characteristics of the Services

HealthConnect moves toward the direction of ‘disease prevention and health management’ and will lead changes through ICT-based innovations. HealthConnect business is defined as three main services: Development of a self-health management service, development of smart hospital solutions to enhance doctor & patient productivity and satisfaction, and establishment of an integrated R&D system for the advancement of the Korean healthcare industry.

First, the development of a self-health management service that links prevention, diagnosis, treatment and management will lead to the provision of truly personalized healthcare service based on one’s medical information;

- Seamless Management using Medical Check-up
 - Personalized program based on medical check-up data.
 - Program result analysis.
- ICT based Personalized Service
 - Activity tracker measuring daily activity.
 - Aerobic/muscle motion data gathering at in-company fitness club.
 - Diet calorie measurement at cafeteria.
- Health-tainment
 - Ranking/Incentive to motivate participation.
 - SNS to encourage family/colleague activity.

HealthConnect plans to develop a health management service model centered on wellness in 2012, followed by a pilot service conducted jointly between SK Telecom and SNUH within the same year.

- Pilot Test Summary
 - Participants: SKT Employees (30 members).
 - Selection Criteria: BMI.
 - Duration: Starting in May 2012 (3 months).
 - Measurement: Comparison of medical check-up data and Satisfaction Index before/after pilot test.

Second, HealthConnect aims to develop smart hospital solutions to level up hospital productivity and patient- friendly environment. For instance, plans are ahead for HealthConnect to create a patient-oriented environment by building smart ICT system within hospitals in 2012.

- Smart Reception & Clinic Information
 - Automatic registration of medical treatment for out-patients.

- Providing medical exam/treatment information based on the clinical pathway and medical contents.
- Smart Payment
 - Payment of small medical bills through NFC enabled smart phones, payment apps and iosk program.
- Smart Indoor Navigation
 - Guide routes to personal destination inside hospital using smart phones and Kiosks.

Besides development of the health management services, SK Telecom and SNUH co-developed Mobile EMR (Electronic Medical Record) and medical self-diagnosis applications in 2011 to accelerate the realization and export of 'Smart Hospital.'

Moreover, the M-prescription application was launched by SK Telecom for mobile healthcare services. M-prescription is expected to significantly enhance patients' convenience by allowing them to store and manage prescriptions on their smart phones and access detailed information on the prescribed medicine including effects, side-effects, dosage and frequency of administration. M-prescription will also help hospitals and pharmacies provide better services and care for patients. Main features of M-prescription include:

- Prescription History.
- Real-time Access to Medication Information & Medication Guide.
- Medication Reminder.
- Search Nearby Hospital/Clinics & Navigation Service.
- General Information on Medicine.

By offering mobile healthcare services that systematically manage an individual's daily amount of physical activity and biometric information, HealthConnect plans to open an era in which individuals are able to manage their own health via mobile phones.

2.11.4 Conclusion

HealthConnect holds a significant meaning in terms of the public healthcare, as it includes services for the medically deprived people and areas. By offering ICT-based healthcare services, HealthConnect will allow people to prevent diseases and manage their health, which will contribute to the overall reduction in social cost and the betterment of national welfare. Furthermore, a portion of its profits will be donated or invested to enhance public healthcare in Korea.

As the pace of adoption of IT in the medical industry has been slower than that of other industries, the combination of SK Telecom's world's top level ICT and SNUH's medical technology and knowhow will develop the next generation healthcare model that connects prevention, diagnosis, treatment and management; promote the export of ICT-based medical services or so-called 'digital hospital'; and enhance Korea's national competitiveness in medical technology and services.

2.12 Singapore: Singapore's e-Healthcare Programmes

2.12.1 Introduction

¹²Singapore experienced rapid population growth in recent years, with the population exceeding five million. This had put a strain on its infrastructure and services. At the same time, Singapore is also facing the prospect of an ageing population where one in five will be over 65 years old by 2030. The national healthcare expenditure is expected to increase and a different pattern of healthcare is necessary; one which features an integrated healthcare delivery system with "right-sited" care, better allocation of resources and more cost-effective treatment and care.

2.12.2 Country Overview

Public healthcare in Singapore is governed by the Ministry of Health (MOH). Institutions that deliver subsidised healthcare are publicly funded through subventions and include 7 acute general hospitals and 6 national specialty centres for cancer, cardiac, eye, skin, neuroscience and dental care. In addition, there are 18 polyclinics located throughout the island that provide subsidised outpatient medical care, health screening and pharmacy services. In the next 4 years, there will be 2 new public hospitals providing additional 1000 beds.

The Intermediate and Long Term Care is provided by residential and communities which are mostly outside the public healthcare system though some facilities receive government subsidies.

In 2000, WHO ranked Singapore's healthcare system ranked first in Asia and sixth in the world. IMD (2007) ranked Singapore's health infrastructure third out of 55 countries. These accolades were achieved on a prudent national healthcare expenditure that is within 4% of Singapore's GDP (a low figure among developed countries)

2.12.3 Objectives and Strategies

There had been a shift in focus from episodic care to developing holistic care to patient. The vision is to have "Hospital without walls" where the healthcare team will comprise GPs, nurses, physiotherapists beside the hospital staff. The team will deliver patient centric care through greater collaboration and partnership. Patients can be decanted more effectively in the healthcare system through the "team based care" so that acute hospitals can cater to severe cases and refer patients in recovery to step down care. This will address the capacity issues of acute hospitals especially in the context of an ageing population.

The National Health Informatics Strategy was conceptualized in 2008 with the goal of achieving greater coordination of healthcare across different providers for patients, higher adoption of Electronic Medical Record systems (EMR) amongst healthcare providers and integrating these EMRs to achieve a vision of "one patient, one medical record" in Singapore. A key part of this strategy is to develop a shared Electronic Health Record which makes available summaries of clinically relevant patient information to healthcare providers to improve the overall quality of care rendered to patients when they seek healthcare services at different points of care throughout their lives. National Electronic Health Record (NEHR) Phase 1 was implemented by 2011 as one of the key guideposts for Singapore's longer term "One Patient – One Medical Record" vision. More capabilities to support clinician collaboration across care setting, harness the power of data via analytics as well as expansion of NEHR adoption across the entire healthcare continuum will be the focus from 2012 to 2016.

In addition, the iN2015 Masterplan by the Infocomm Development Authority (IDA) set out a 10-year plan to utilize infocomm technologies to establish a well connected society. For the healthcare sector,

¹² Contribution: Government ICT Strategy and Performance Management (ISPM), Infocomm Development Authority of Singapore (IDA), Singapore. See document [RGQ14.3.2-C-0018](#)

personalized healthcare delivery was a future envisioned to be enabled by infocomm to achieve high quality clinical care, service excellence, cost-effectiveness and strong clinical research.

2.12.4 Activities Implemented

MOH did a review of healthcare landscape and had implemented a concept known as Regional Health System (RHS). There are six RHS formed to serve the different geographic locations in Singapore. The RHS realised the vision of "Hospital without Walls" by providing integrated care to patients. The RHS will involve an acute hospital as anchor to work closely with key healthcare providers in the region i.e. General Practitioners and step down care providers such as community hospitals, nursing homes and hospices. Together, the institutions were to take a patient-centric approach, as opposed to the traditional institution-centric approach. To support the RHS concept, there will be a need to improve the healthcare ICT capability especially in the area of connectivity between institutions. NEHR will be used as a common reference to Patient Record.

2.12.5 Technologies and Solutions Deployed

National Electronic Health Record (NEHR)

To improve healthcare quality for all residents, increase patient safety, lower healthcare costs and develop more effective health policies, Singapore's Ministry of Health (MOH) created the National Electronic Health Record (NEHR) vision – "One Singaporean, One Health Record".

The NEHR extracts and consolidates in one record all clinically relevant information from the patient's encounters across the healthcare system throughout his/her life. It allows for data sharing, making it accessible to authorised healthcare providers, across the continuum of care throughout the country.

With the NEHR, healthcare teams would be better equipped to provide more effective care as the system will enable more timely access to health records including diagnoses, prescriptions and allergies. This will help reduce medication errors and adverse drug events. There will also be cost savings as healthcare staff will be able to obtain a more complete and accurate picture of the patient's health history and therefore avoid ordering duplicate or unnecessary tests.

Integrated Clinical Management System (CMS)

Launched in 2006, the Integrated Clinic Management Systems (CMS) program aims to encourage GP clinics to adopt and leverage on infocomm technologies to facilitate operations and clinical improvements in their patient care. The integrated CMS facilitates scalability of the GP infrastructure by enabling consistent and standards based interface with different healthcare provider systems. Secured and seamless information flow will allow GPs to plan the patient's treatment in an integrated and coordinated manner with other hospitals and step-down care providers. Through this program, GPs will have the capability to easily plug into the national healthcare network and achieve MOH's "One Singaporean, One Electronic Medical Record" vision.

GP-IT Enablement Programme

Building on the momentum of the CMS Program which has resulted in most GPs having some form of IT system in place, the GP-IT Enablement Program was conceptualized in 2010 as the next phase of GP IT adoption. It aims to support more sophisticated IT usage for GPs through introduction of an IT-enabled clinical foundation that contains linkages to the National Electronic Health Record (NEHR) and care services such as laboratory and diagnostic radiology results. GPs currently participating in the CMS Program will be transited to the IT-enabled clinical foundation when the system is implemented.

Intermediate and Long-Term Care (ITLC) IT Enablement Programme

The ILTC sector comprises residential and community-based services and is currently managed mostly (approximately 70%) by voluntary welfare organisations (VWOs), where resources are usually stretched,

clinical documentation capability or management is limited, IT usage is minimal and IT expertise a scarce occurrence. To address these issues, the ILTC Programme consists of an IT strategic framework that aims to establish the core foundation for the use of technology across ILTC settings, for operational efficiency, and subsequent electronic exchange of information between care settings within the ILTC sector and nationally to the National Electronic Health Record (NEHR). In addition, an ILTC IT Adoption Model will be developed to categorise the IT adoption of different care facilities, to allow policy planning to better develop specific programmes to meet the needs of care facilities with similar maturity levels, and to increase industry interest in the ILTC sector to explore more innovative & sustainable solutions and develop more targeted products and services for the care providers and care givers.

Telehealth Programme

With the increasing challenges of the healthcare sector, Singapore needs to explore more innovative ways to deliver healthcare services, and Telehealth is one such area. Telehealth is an area where ICT can improve the delivery of healthcare services and where the ability of patients to be more proactive in their health management can be enhanced, thereby increasing care accessibility, enhancing care quality and delivery, and bring more affordable care through greater operation efficiency. It aims to empower patients to better self-manage their health while collaborating with healthcare providers to ensure care continual.

The Telehealth Programme has been formulated to identify and develop remote healthcare services via ICT including mobile technologies in an affordable and sustainable manner for both patients and healthcare providers. Through this programme, it aims to increase greater Telehealth adoption through more coordinated efforts and optimized investment across the entire healthcare ecosystem.

The programme will drive the development of a Telehealth framework which will establish a tripartite relationship between the patients (with their care givers), healthcare providers, and technology as the necessary bridging platform, with an overarching governance to provide implementation guidance and oversight. It includes development of needs assessment and implementation guidelines, thus aligning and synergizing the various initiatives across the healthcare sector including institutions, government agencies and industry.

2.12.6 Changes and Outcomes Achieved

National Electronic Health Record (NEHR)

Phase 1 of NEHR completed in Jul 2012 with common patient records available to all public acute care hospitals, specialist clinics, polyclinics, selected GP clinics, five community hospitals, two nursing homes, one hospice and supporting organizations like Agency for Integrated Care (AIC), Health Promotion Board (HPB) and Singapore Armed Forces medical corps. Phase 2 of the NEHR will provide additional features and functionalities to support patient care and data analyses.

GP-IT Enablement Programme

CLEO (Clinic Electronic Medical Record and Operations), a national system developed for the primary care will comprise of an EMR and an integrated CMS (clinic management system). Phased rollout is expected to begin from 2013.

IDA had awarded a grant to Quest Laboratories to develop a system that delivers secured, electronic lab results online and to NEHR (via the General Practitioner Clinic Electronic Health Record and Operations or CLEO) that comply to the Singapore HL7 standards for messaging and LOINC international standards for diagnostic results. The system will transform a traditional, paper-based process of GP practice to one that is IT-enabled, offering timely and comprehensive electronic documentation of a patient's health condition when integrated with NEHR. It will also leapfrog Singapore's status as one of the few countries in the world with such high level of IT sophistication in pathology services. The system will be completed by March 2013.

Telehealth Programme

MOH Holdings (MOHH) had established a programme office (Consumer Health Office) to oversee the programme. As part of the programme, Integrated Health Information Systems (IHIS), a subsidiary under MOHH, had also established a Telehealth Technology Office (TTO). The TTO will build (when necessary), implement, operate and support Telehealth solutions. By aligning and consolidating potential Telehealth initiatives across the clusters and community, TTO will assist institutions to achieve economies of scale through consolidated procurement, therefore optimising the limited manpower and financial resources.

MOHH has recently completed a local landscape study of Telehealth implementations by the different healthcare institutions. The study seeks to understand the major pain points and barriers to adoption of Telehealth. The results of the study will help to guide the programme office in developing the framework for assessing and regulating Telehealth.

IDA had launched the Telehealth Call For Collaboration (CFC) earlier in March 2012 to invite the industry to develop new models of distance care for the elderly - at home, within the community or at institutions such as nursing homes - assisted by ICT. Launched in collaboration with the Ministry of Health, it is hoped that the CFC will encourage healthcare providers to review existing care models and care processes, to ensure sustainability through appropriate change management, manpower training and benefits measurement and demonstrate viable business models for longer terms deployment of Telehealth services. It is predicted that Telehealth will be a key enabler behind strategies that are being adopted to enable "ageing-in-place" as Singapore prepares itself for a rapidly ageing population. Results of the CFC will be announced in early 2013.

2.12.7 Challenges and Success Factors

National Electronic Health Record (NEHR)

As there are six clusters and over 30 institutions in Singapore, it is a challenge to take in the data, process and display accurate and meaningful data. The implementation of the NEHR system has provided an even stronger spotlight on issues such as standards and data quality, as previously unknown inconsistencies and data defects from a variety of catchments flow into a unified record. The data includes information which is non-clinical such as information used to identify people, organizations, locations and departments etc. A national strategy was developed to govern the creation, implementation and management of standards in health information exchange.

The journey and results of any delivery are predictable if the challenges ahead were identified and dealt with. When deploying the NEHR to new institutions, the project team was able to re-use product, process and people, supported by tried and trusted methods.

Telehealth Programme

There were a number of telehealth projects led by the various health institutions. These initiatives include; National Healthcare Group (NHG) Diagnostic's remote radiology reading service, and Khoo Teck Puat Hospital (KTPH) nursing home-geriatrician video-consultation initiative. These projects demonstrate that effective and clinically-led sustainable Telehealth is possible in Singapore. There was however challenges that will need to be tackled such as lack of sustainable business models, clinician support being hampered by liability. Other concerns such as lack of IT infrastructure, patient billing, provider reimbursement issues, security and privacy concerns, and lack of standards will need to be addressed as well.

The challenges will be systematically addressed by the MOHH Consumer Health Office. For example, to address the business model and sustainability issues, the project assessment criteria will include the presence of a viable and validated business model.

Unlike other countries where telecommunication infrastructure is a key barrier, Singapore is well equipped for adoption of Telehealth given our high mobile penetration, excellent network connectivity and high speed broadband, and increasingly empowered population. Coupled with clinical leadership and

commitment, Singapore can push towards greater Telehealth adoption across the care continuum and position as a Telehealth thought-leader within Asia Pacific.

2.12.8 Lessons Learned and Next Steps

NEHR

The full implementation of NEHR is an iterative one and will take years to complete, allowing each deployment cycle to refine and improve on the previous one.

Singapore's adoption of the NEHR will change the healthcare landscape in the country for the better. The NEHR is a journey to transform the mindset of healthcare providers and patients, so as to bring about better quality care. Once the NEHR is fully implemented, the possibilities of future development in areas of prevention and treatment are vast. In addition to contributing to high quality care and service excellence, the NEHR will bring us closer to achieving our vision of "One Singaporean, One Health Record".

NEHR Beyond Acute Hospitals

IT implementation and adoption strategies for the intermediate and long term care (ILTC) and primary care sectors are being developed. While the IT adoption rate is still low at the primary care level, IT enablement among GP practices and Community Hospitals will progress with linkages to the NEHR.

The use of IT will enable patients' critical medical information flow from the acute hospitals to the primary and intermediate long term care sectors. There will be support for Community Hospitals (rehabilitation hospitals) to modernise patient administrative, pharmacy and clinical systems. Upgrading, enhancing and improving of systems in nursing homes, day rehabilitation centres and home nursing providers are also underway.

In the long run, healthcare providers will be able to better develop, integrate and coordinate shared care plans to provide better quality care. The end goal is for patients to enjoy a hassle-free healthcare delivery service, with fewer repeat tests and reduced medication errors when they move from one care setting to another, with the NEHR linking up providers in the community who currently do not have electronic access to patients' medical records.

For patients, it means better prescribing practices, reduced waiting times and better management of the quality and cost of healthcare by ensuring the most appropriate care setting for their conditions.

Telehealth Programme

Over the past few years, there have been multiple efforts in Telehealth exploration by various healthcare institutions and government agencies; with varying results. These range from government-funding programmes such as IDA Yr 2006 CFC to ground-up institutional initiatives such as video conferencing partnerships. However, these efforts are largely sporadic and relatively unsustainable. One key factor was an overall lack of coordination in pushing forward the adoption and innovative use of Telehealth in Singapore. As such, it is hoped that the establishment of a Telehealth framework will help coordinate the various Telehealth efforts and guide its implementation.

The Telehealth Framework aims to identify services that will deliver remote healthcare services via ICT including mobile technologies in an affordable and sustainable manner for both patients and healthcare providers. Through this framework, it will set the directions for Singapore Telehealth adoption across the entire healthcare ecosystem and identify low-hanging or high-potential areas to which more coordinated efforts and investment can be delivered.

This will also establish a consistent assessment framework for Telehealth efforts, thus aligning and synergizing the various initiatives across the healthcare sector including institutions, government agencies and industry. As part of the framework, a set of implementation principles will be developed to help guide the implementations and facilitate subsequent best practices sharing.

2.13 China: Perspective for e-Health Using Satellites

1 Concept of e-Health Using Satellites

¹³ E-health is medical activity by cooperation of medical institutes in different areas, which is realized by computer technology and telecommunication technology. Typical solution of e-health is by satellite communications system, ISDN or telephone facilities. In an e-health system using satellite, the communication links are realized by satellites, in despite of the disadvantage of e-health using terrestrial facilities. Typically, an e-health system using satellite is comprised of a telecommunication satellite, main teleport, a quantity of terminals, related software and protocols.

2 Advantages of e-health using satellites

- Larger service area: Satellite communications system could provide large coverage that even rural and wild areas can be included, so the problem of sharing and equity of health resources in developing and developed areas are easier to resolve.
- Wide bandwidth: Until now, the bandwidth of one channel of broad band telecommunication satellite could reach as much as 200 MHz, it is a big advantage comparing to the bandwidth of terrestrial communication systems, especially in developing countries.
- Flexibility and extensibility: No matter it is in deserts, oceans, mountains, or hills, an e-health system is possible to be operated if it's in the service area of a satellite.
- Hard to break down: Terrestrial communication systems are always destroyed when disasters such as earthquake or tsunami happens. At this time, e-health systems based on satellites is the only communication way for rescue and rebuilding in disaster area.
- Cheaper, shorter construction period: Compared to other communication system, the prices of system infrastructure and user terminal are cheaper, the constructing is easier and its period is shorter.

3 Application Scenarios of e-Health using Satellites

3.1 Point-to-Point Health Service

In a point-to-point health service, experts could use health data collecting and diagnosing devices, such as digital imaging instrument, ultrasonic detection automatic recording instrument, to collect high resolution CT scanning figures, X-ray images. In the diagnosing process, real-time telecommunication is feasible. Despite of remote diagnosing, doctors could use remote control system to operate mechanic arms to conduct a surgery, in which the communication link is built by satellites.

Once consultation is needed, video conference may be supported by the point-to-point health system. Using satellites communication links, any terminal could be used as the main terminal and the other terminals are used as sub-terminals. Any links between different terminals are in two-direction pattern. Real-time connection is realized between them and in this way medical institutes in different sites could deal with business simultaneously.

3.2 Education for e-Health

In disaster or epidemic areas, an e-health system by satellites could improve the medical level much rapidly. For example, one expert provides lectures at the main terminal and other people could receive information and reply by their local terminals. By this way, some emergent knowledge about first aid and epidemic prevention is transmitted and broadcasted.

¹³ See document [2/332](#)

3.3 Data and Information Sharing for e-Health

In every dispersive area, hospitals can found local information centre and expert database, collect local health requirements and upload them to expert service centre of e-health system. The expert service centre of e-health system could provide proposals and methods according to the requirements and realize the sharing of software and data through health information broadcasting by satellites.

3.4 Proposal

Huge investment is needed for any space telecommunication system, and permanent maintenance is also necessary. For a developing country with limited financial ability, it's a good way to build up its e-health system using satellite according to the specified situation in this country.

In primary phase, it's better to build up an e-health system by renting transponders of civil or other countries' satellite. When the requirements are mature and the fund is sufficient, one country can build up a new satellite system aimed at public service, in which e-health is one of the main purposes.

The scale of satellite multimedia service is increasing all over the world, so are the user's requirements. Under this situation, broad band satellites technology is becoming one of the trends of satellite telecommunication in the future. By the way, it's necessary to consider the compatibility between current satellite facilities and the future satellite system, such as the broad band satellite system.

It is suggested to conduct the satellite hardware construction, the telecommunication system research, and business mode exploring synchronously.

2.14 India: Setting up of Rural Tele-medicine Network in Developing Countries

¹⁴ The contribution is a case on implementation of Tele-Medicine project through Pan – African E-Network Project by M/s Telecom Consultants of India Limited, a Government of India Enterprise. The project has been very successful and won several awards for innovation. This model could be used as an example for providing Health services through ICTs in the developing countries.

1 Introduction/Background: TCIL Experience of Design, Development and Operations of Tele-medicine Networks

TCIL has implemented and operating Tele-education and Tele-medicine network projects of pan African e-Network Project, wherein 5 reputed Indian universities and 12 Indian super specialty hospitals are connected to 48 of the 54 member countries of African union for providing Tele-education and Tele-medicine. TCIL is implementing agency on turnkey basis covering design, development, supply, installation, commissioning and operations of the network.

The network is operating for more than 5 years and African countries have benefitted from the medical expertise and know how in India via this network. The CME sessions conducted from India on daily basis have helped the medical professionals in education and sharing of experiences. TCIL is implementing agency on turnkey basis covering design, development, supply, installation, commissioning and operations of the network including providing education and medical services through the Indian universities and hospitals. TCIL has also implemented SAARC telemedicine network spread across for the SAARC nations.

Pan African e-Network Project has been awarded of “Best Development Initiative in Africa – 2009” and “Hermes International Award for Innovation”.

2 TCIL Proposal

¹⁴ See document [2/INF/87](#)

The aim of this service is to provide health checkups and diagnosis for non-emergency medical conditions and thus eliminating the need to travel to cities for treatment of minor ailments. This service would enable the rural population to demand medical services at their door steps. A medical call center would be established which can be contacted over a toll free number. This service would bridge the gap between the rural population and specialty medical care and thus benefitting both.

These services would be provided either through paramedics or general practitioners. Medical Diagnostic kit can help in providing the Frontline Health worker to perform diagnostics tests and then employ decision support system to offer care to all primary care patients. In the case of emergency or situations where further consults are required, the medical officer can use the Satellite or Broadband connectivity to offer telemedicine facility.

Paramedics are one of the first points of contact for many populations. Empowering them with Medical Diagnostic Kit, the on-the-spot recommendation system and guidance by physicians through the phone/videoconferencing will allow them to monitor patient health and also identify high risk cases which need immediate care by physicians. In this way, such a system could help better care delivery and a more efficient system for rural population.

Figure 33: Rural tele-medicine network

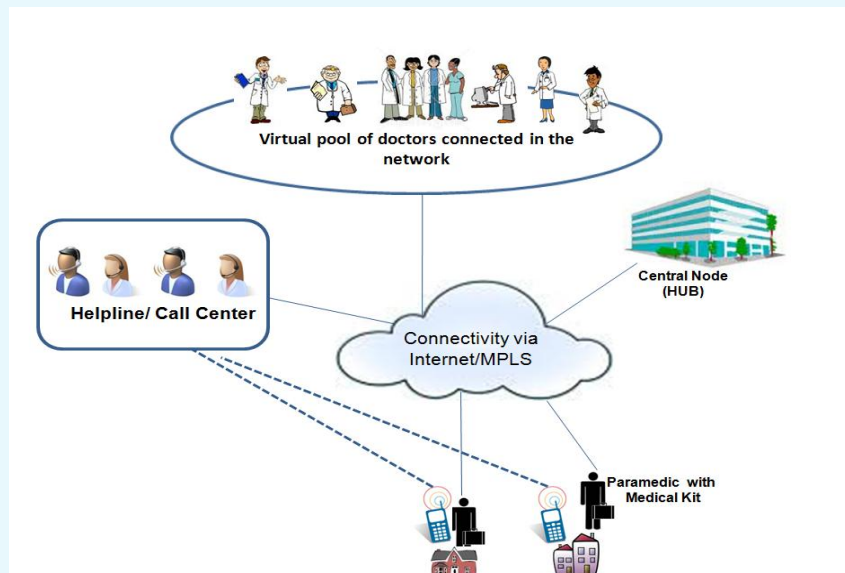

Workflow of the rural tele-health services

- 1 Services shall operate through the call center for providing the medical assistance to the patients in the rural areas.
- 2 Call Center would be equipped to receive the help calls by following means:
 - a. Helpline telephone numbers;
 - b. Web-based access.
- 3 Residents can register their requests for medical services by approaching the call center by available communication means.
- 4 The call center shall alert the paramedic near to the location of the caller or service seeker and forward him the request details for attending the patient.
- 5 Paramedic is equipped with sufficient diagnostic equipment to examine the patient.

- 6 Paramedic on examining of the patient shall report the details through internet and seek an appointment with a doctor from Primary Health Centers (PHCs).
- 7 PHCs doctor list and contact details would be available in the data base and paramedic can contact the doctor of the particular PHC for getting medical support.
- 8 The entire diagnosis and medical history shall be available to the doctor by accessing the central server.
- 9 Doctor shall provide the necessary prescription online into the system which shall also be available to paramedic for handing over the same to the patient.
- 10 The medicine shall be arranged by the patient separately from PHCs or chemists.
- 11 The Call Center and Data Center would be located at a mutually agreed upon location.

3 Proposed Technical Solution

Components of the rural tele-medicine solutions and their roles for delivery of rural tele-medicine services:

- a) Role and responsibilities of 24X7 Toll free helpline/call center
 - i. The patients from rural areas can call the helpline for immediate medical assistance for an emergency or to request for a health checkup. Depending on the call it may be forwarded directly to a physician for immediate advice.
 - ii. Initially a call center with a staff of 5 agents and 2 doctors may be setup for the pilot project. The call center's call handling capacity would be increased as per the increase in the call traffic.
 - iii. The call center would inform the callers about the schedule for paramedic staff visiting their area and also accept request for health checkup.
- b) Role and responsibilities of paramedic staff
 - i. Paramedics would be hired to travel to various regions of the targeted area to provide health check up and medical assistance. Paramedics would be equipped with a medical diagnostic kit and medical vehicle to carry the patient to a Specialty Hospitals if required.
 - ii. As per the requests for health check up received, a paramedic staff would visit the concerned patient.
 - iii. The paramedic visiting a patient would prepare and upload the EMR online on the central server.
 - iv. The paramedic would also transfer the medical reports generated over the medical kit to the centralized server.
 - v. The paramedic can also communicate with a specialist using the medical kit's Video Conferencing facility.
 - vi. Paramedic staff would be provided with a mobile phone with GPS facility.
- c) Role and responsibilities of primary healthcare centres
 - i. Primary health centers may play a key role in this network. They may also initiate a call to the call center for tele-consultation with a specialist as needed. They may also act as the health checkup center when the paramedic with medical diagnostic kit arrives in that area.
 - ii. Primary Health Centres may also appoint doctors to take calls from Paramedic Staff and to assist them remotely.

- d) Role and responsibilities of doctors in the virtual pool
- i. A pool of doctors from various Primary Health Centres would be enabled to connect in the network over internet.
 - ii. These doctors would help the paramedic personnel in the rural area visiting the patient and give a prescription.
 - iii. The doctors would be able to see the Patient record online from login into the Central Server.

e) Medical kit

The medical kit is a revolutionary device that enables remote diagnostics and care employing state of the art mobile system. It would allow any Android Phone or Tablet to perform following diagnostics tests:

- i. Blood Pressure.
- ii. Blood Sugar.
- iii. Heart Rate and Heart Rate Variability.
- iv. ECG.
- v. Urine Protein.
- vi. Urine Sugar.
- vii. Blood Hemoglobin.
- viii. Body Temperature.

4 Stakeholders

- ITU.
- Participating interested countries.
- TCIL as implementing agency for the project.
- Participating Hospitals for delivery of Tele-medicine sessions and CME programs.
- Beneficiaries patients.

5 Approach for Project Implementation

Approach and methodology:

After intent of countries to implement Rural Tele-medicine network, TCIL shall carry out detailed meetings into the country for implementation of the Rural Tele-medicine solutions whereby it will do the following:

- TCIL shall identify in association with stake holders the Medical treatments at site to be covered, identification and finalization of Super Specialty Hospitals, Primary Health Centres etc. for delivery of Tele-medicine services.
- TCIL shall carry out a sample survey of few locations.
- TCIL shall design the network for setting up the required infrastructure.
- TCIL shall finalise Bill of Materials (BoM), Bill of Quantities (BoQ), availability/ coverage of public network etc.
- TCIL shall develop the framework of implementations of Tele-medicine as per the countries requirements.
- TCIL shall train the countries' manpower for operations & management of the network.
- A project monitoring team will monitor the different activities of the project.

Responsibility of countries:

- Network for Tele-medicine such a leased lines, internet, MPLS shall be provided by the interested country.
- Space, power/electricity shall be provided by respective countries.
- Site preparation shall be provided by the respective country.
- Man power for operation and maintenance shall be provided by the respective countries.
- Any other local assistance regarding clearance, Visa, survey etc.
- Exemptions such as taxes, custom duties will be provided by the country.
- Day to day Consumables at respective sites will be provided the respective country.

About TCIL

TCIL, **Telecommunications Consultants India Limited**, a prime engineering and consultancy company, is a wholly owned Government of India Public Sector Enterprise under the administrative control of the Department of Telecommunications (DOT), Ministry of Communications and Information Technology, Government of India. TCIL was set up in 1978 for providing Indian telecom expertise in all fields of telecom, Civil and IT to developing countries around the world. Company's core competence is in the fields of Switching, Transmission Systems, Cellular services, Rural Telecommunication, Optical fibre based backbone transmission systems, IT & Networking Solutions, Application Software, e-Governance, 3G Network, WIMAX Technology and also Civil construction projects. <http://www.tcil-india.com/new/>

For more details on Pan African E Network Project: <http://www.panafricanenetwork.com/>

Contact Details: Mr E.M. Venkatesh, General Manager (TS), Telecommunications Consultants India Limited, Tel.: +91 11 2620 2590, E-mail: em.venkatesh@tcil-india.com

Annex III: Compendium of e-Health Projects for RMNCH Implemented in CoIA Countries

	e-Health project	Description	ICT application	Country
1	e-Districts Project for services of births and deaths registration in district of Kapurthala, India	Integrated electronic service supported by automation workflow, backend computerization, and data digitalization. The objective is to ensure that the defined process of service delivery of birth/death certificates is adequately and timely followed. http://pbhealth.gov.in/e-district.crs.pdf	Civil Registration Health Management Information System (HMIS)	India
	MAMA	Mobile-based information to new and expectant mothers. http://www.babycenter.com/mama	SMS-based Public Health Information and Education	Bangladesh South Africa India
3	MOVE IT	Mobile-based registering of pregnancies, recording of births, deaths and cause-of-death, using text messaging system. http://www.who.int/healthmetrics/news/MOVE_IT_Africa_Board_Paper_21.2.12.pdf	Civil Registration	Ghana
4	Project Mwana	Mobile application based on RapidSMS, used by community health workers (CHWs) to register new births and monitor community health events related to malaria, diarrhoea, and immunizations in children under five years old and expectant mothers. http://projectmwana.posterous.com/	Civil Registration	Malawi
5	Universal Birth Registration	Mobile birth registration system focused on informing and educating the public about the birth registration processes. http://plan-international.org/birthregistration	Civil Registration	Liberia
6	Aceh Besar midwives	Mobile phones to improve the quality of health services and reinforce positive health behaviour change, such as child spacing. http://www.mobileactive.org/files/file_uploads/final-paper_chib.pdf	SMS health education	Indonesia
7	AMUA	SMS is used to send monthly service reports for 12 services in a single text, using a numeric code. Data can be viewed on a Web-based real time reporting system , and exported as PDF or CSV files. http://mariestopes.org/ShowContent.aspx?id=430	Health Management Information System (HMIS)	India

	e-Health project	Description	ICT application	Country
8	ChildCount+	Mobile application based on RapidSMS to monitor children under five years old. http://www.childcount.org/	m-Health for data collection Community-based healthcare delivery	Kenya
9	CycleTel: Family Planning via Mobile Phones	Standard Days Method (SDM) displayed directly to a user's cell phone . SDM is a fertility awareness-based method that requires the user to avoid unprotected sex during days 8-19 of her menstrual cycle. http://www.coregroup.org/storage/CycleTel_mHealth_WG_Jan2011-1.pdf	SMS-based Public Health Information and Education	India
10	e-IMCI	Electronic job aid on PDA to improve adherence to the Integrated Management of childhood Illness (IMCI) protocols. http://www.d-tree.org/our-projects/imci-tanzania/	Point-of-care support and diagnosis	Tanzania
11	mCare	Mobile phone and database technologies used to improve registration and monitoring of pregnancies, as well as neonatal and post-partum care. http://www.mobileaware.com/solutions/mobile-self-service/	m-Health for Data collection Community-based healthcare	Bangladesh
12	M-CHANJO	Mobile health application that seeks to reduce the rate of child mortality. The system works by sending automated reminders via SMS to parents to keep them informed on any future immunization dates and appointments for their children. http://mchanjo.org/	Child Death Surveillance SMS health education and reminder	Kenya
13	Medic mobile (Frontline SMS)	Mobile-based technology to bridge between patients and physician, mainly for family planning and maternal and child care services. http://medic.frontlinesms.com/	Patient monitoring	Bangladesh
14	mUbuguzima	Cell phones are used to enable community health workers (CHWs) to provide real-time data concerning community health indicators. http://mubuzima.gov.rw	Data collection	Rwanda
15	SMS alerts for Infant vaccinations	e-Vaccination Alert System connected to 'Hospital Kiosks' where parents register the birth of their child. Alerts on vaccination dates and details on their importance will be automatically sent to the mobile phone numbers of parents. http://www.healthunbound.org/content/sms-alerts-infant-vaccinations	SMS health education Point-of-care support	India

	e-Health project	Description	ICT application	Country
16	AMANECE	<p>Mobile phones are used to detect warning signs and typical symptoms of high-risk pregnancies, to support primary health workers in providing monitoring and follow-up for high-risk pregnancy cases, and to ensure timely obstetric and newborn care interventions.</p> <p>http://www.salud.carlosslim.org/Solulnt e/amanece/Paginas/AMANECE.aspx</p>	<p>Patient monitoring</p> <p>Point-of-care support and diagnosis</p>	Mexico
17	ASARA-HMRI	<p>Telemedicine pilot project aimed at reducing maternal mortality among remote tribal women.</p> <p>http://www.hmri.in/oursolutions-telemedicine.html</p>	<p>Remote monitoring</p> <p>Diagnosis and treatment support</p>	Kenya
18	BabySMS	<p>Free SMS-based pregnancy advice service to help raise awareness and encourage expectant mothers to attend clinic visits regularly.</p> <p>http://babysms.mobi/index.php</p>	<p>SMS health education</p> <p>SMS reminder</p>	South Africa
19	Cellphone4HIV	<p>SMS is used to expand the uptake of HIV testing and follow-up in PMTCT.</p> <p>http://www.cell-life.org/</p>	<p>Patient monitoring and support</p> <p>SMS health education</p>	South Africa
20	Changamka Medical Smart Card	<p>Smart Card provides sustainable financing for delivery, and post-natal services at participating facilities.</p> <p>http://changamka.co.ke/</p>	<p>Mobile financial services</p>	Kenya
21	CommCare	<p>CHWs use electronic forms to access real-time guidance through key counselling points, decision support, and simple referral algorithms.</p> <p>http://www.CommCareHQ.org</p>	<p>Health Management Information System (HMIS)</p> <p>Patient monitoring</p> <p>Point-of-care support and diagnosis</p>	17 countries in Africa, Asia, and America
22	CliniPak	<p>Automatic text message reminders for patients receiving ongoing treatment and for mothers requiring post-natal care for themselves and their infants.</p> <p>http://www.vecnacares.org/technology/index.shtml</p>	<p>Point-of-care support and diagnosis</p> <p>Medication reminder</p>	Kenya
23	E-HealthPoint	<p>Tele-medical services providing referrals to district-based hospitals for situations like childbirth, acute trauma, heart attack, cancer, and accident related emergencies.</p> <p>http://www.ehealthpoint.com/</p>	<p>Patient monitoring</p> <p>Point-of-care support and diagnosis</p>	India
24	FANC	<p>Short Messaging Service (SMS) platform that allows for two-way exchange of key FANC messages between health personnel and pregnant women.</p> <p>http://www.fanc-africa.org/</p>	<p>SMS health education</p>	Kenya
25	GlobalMama	<p>Blog dedicated to maternal health.</p>	<p>Health education</p>	Global

	e-Health project	Description	ICT application	Country
		http://blogs.medscape.com/mhtfglobal/mama		
26	HealthLine	Toll-free number for health workers to learn about a variety of topics through audio transmission in native language. http://www.cs.cmu.edu/~healthline/	Health helplines	Pakistan
27	Health Systems 20/20	Mobile based financial services for interventions in financing, governance, operations, and capacity building to strengthen health systems. http://www.healthsystems2020.org/	Mobile financial services	Global
28	inSCALE	Mobile based system to improve support supervision, data submission with automated individual feedback and regular motivational messages on how to improve performance and appropriate treatment of children. http://www.malariaconsortium.org/inSCALE/pages/implementation-sites/uganda	Health education	Uganda Mozambique
29	Jaroka Tele-Health care Services for Lady Health Workers	Mobile platforms to extend (1) tele-healthcare based services including SMS, MMS, GPRS/Edge and VSAT , (2) medical advice to LHW in the field by connecting them to a network of specialists. http://tele-healthcare.org/implementation/jaroka-tele-healthcare-in-rural-mardan/	Telemedicine Point-of-care support and diagnosis e-Diagnosis	Pakistan
30	KimMNCHip	Mobile health initiative to offer pregnant women in Kenya more choice, control and care during their pregnancy, and improved medical care for women and their babies during and after delivery. http://www.ghf12.org/?p=2154	Patient monitoring Point-of-care support and diagnosis Maternal and Child Death Surveillance	Kenya
31	mDhil	Health information via SMS as well as original health videos viewable on mobile phones, including maternal health. http://www.mdhil.com/	SMS health education	India
32	MoTech	Mobile based health system improving management patient data, improving worker performance, and providing last-mile supply chain and patient adherence. http://www.grameenfoundation.org/what-we-do/technology/mobile-health	m-Health for CHW Training Data collection Diagnosis and treatment support	Ghana
33	Pesinet	Mobile phone -based system monitoring information on mother and child health. http://www.pesinet.org/	Maternal and Child death surveillance Monitoring and evaluation	Mali

	e-Health project	Description	ICT application	Country
34	RAFT	Tele-expertise, ultrasonography with remote supervision by specialists, particularly for supporting diagnosis for pregnant woman, and collaborative development of educational on-line material. http://raft.hcuge.ch/	Remote monitoring e-Diagnosis Patient monitoring and support Monitoring and evaluation Health Education Point-of-care support	Congo-Brazzaville + 17 countries in Africa
35	RapidSMS	SMS based system to track pregnancies and support maternal, neonatal and early child health. http://rapidsms.moh.gov.rw/	Monitoring and evaluation SMS reminder	Rwanda
36	RHEA	Health information system to improve maternal and child care in Rwanda at health centre level. http://rhea.jembi.org	Monitoring and evaluation	Rwanda
37	SHINE	Web and mobile-based system addressing the data management needs of doctors, nurses, midwives and allied health professionals. https://www.shine.ph/	Data collection Health Information System	Philippines
38	SMART	Small battery-operated printers program to receive and print early infant diagnosis test results to strengthen early infant diagnosis services by speeding up results delivery and treatment eligibility. http://www.sms2printer.co.uk/pages.php?pageref=clinton-foundation_3	Diagnosis for treatment support Monitoring and evaluation	Mozambique Papua New Guinea Cameroon Zimbabwe Tanzania Ethiopia Malawi Kenya Uganda
39	SMS Tech for Health txt4Enat	Mobile based system to inform women about pregnancy and collect information transmitted via the handsets to a central computer system . https://smsinaction.crowdmap.com/reports/view/162	Point-of-care support Monitoring and evaluation	Ethiopia
40	Text4baby	SMS based system providing new and expectant mothers with information. http://text4baby.org	SMS health education	Global
41	TulaSalud	Telemedicine and mobile phones for remote diagnostic and decision-making support from physicians in urban centre and receive calls from people in communities seeking for care. http://www.tulasalud.org	Telemedicine m-Health for CHW Training	Guatemala
42	UNICEF Reminder Mother System	Mobile phones to increase antenatal care and prevention of mother to child transmission by educating communities. http://www.texttochange.com	Health education SMS reminder	Uganda

	e-Health project	Description	ICT application	Country
43	Wawared	Mobile technology solutions to support maternal and child care by improving access to health services for low-income pregnant women. http://www.wawared.andeanquipu.org/	Diagnosis and point-of-care support Monitoring and evaluation	Peru
44	Wazazi Nipendeni	Free SMS service for expectant mothers and families that provides appointment reminders and tips on keeping mothers and newborns healthy. http://www.texttochange.org	SMS Health education SMS reminder	Tanzania
45	Wired Mothers	SMS reminders to pregnant women for care appointments. http://www.enrecahealth.dk/archive/ffuproposal09wiredmothers.doc/	SMS reminder m-Health for CHW Training	Tanzania

Annex IV:Composition of the Rapporteur Group for Question 14-3/2

Question	Title of the Question/Role	Name/Country/Organization	Focal Point
Question 14-3/2	Information and Telecommunications for e-Health		Mr H. Eskandar
	Rapporteur	Mr Leonid Androuchko (Dominic Foundation)	
	Vice-Rapporteur	Dr Malina Jordanova, MD, PhD, Space Research & Technology Institute, BAS, Bulgaria	
	Vice-Rapporteur	Ms Tania Logbo Allomo, Côte d'Ivoire	
	Vice-Rapporteur	Mr Abdoulaye. Kébé, Guinea	
	Vice-Rapporteur	Dr. Isao Nakajima, MD, PhD, Tokai University, School of Medicine, Japan	
	Vice-Rapporteur	Dr Mikhail Natenzon, TANA, Russian Federation	
	Vice-Rapporteur	Mr Arikan Dalkiliç, Türk Telekom Group, Turkey	
	Vice-Rapporteur	Mr Turhan Muluk, Intel Corporation, United States of America	

Annex V: Glossary

- EC** – European Commission
- EU** – European Union
- GDP** – Gross Domestic Product
- GNI** – Gross National Income
- ICT** – Information and Communication technology
- IMF** – International Monetary Fund
- IT** – Information Technology
- ITU** – International telecommunication Union
- ROI** – Return of Investment
- TSA** – Telecare Services Association
- UN** – United Nations
- UNDP** – United Nations Development Programme
- WHO** – World Health Organization

Unión Internacional de las Telecomunicaciones (UIT)
Oficina de Desarrollo de las Telecomunicaciones (BDT)
Oficina del Director

Place des Nations

CH-1211 Ginebra 20 – Suiza

Correo-e: bdtdirector@itu.int

Tel.: +41 22 730 5035/5435

Fax: +41 22 730 5484

Director Adjunto y
Jefe del Departamento de
Administración y Coordinación
de las Operaciones (DDR)

Correo-e: bdtdeputydir@itu.int

Tel.: +41 22 730 5784

Fax: +41 22 730 5484

Departamento de Infraestructura,
Entorno Habilitador y
Ciberaplicaciones (IEE)

Correo-e: bdtiee@itu.int

Tel.: +41 22 730 5421

Fax: +41 22 730 5484

Departamento de Innovación y
Asociaciones (IP)

Correo-e: bdtip@itu.int

Tel.: +41 22 730 5900

Fax: +41 22 730 5484

Departamento de Apoyo a los
Proyectos y Gestión del
Conocimiento (PKM)

Correo-e: bdtipkm@itu.int

Tel.: +41 22 730 5447

Fax: +41 22 730 5484

África

Etiopía

International Telecommunication
Union (ITU)

Oficina Regional

P.O. Box 60 005

Gambia Rd., Leghar ETC Building

3rd floor

Addis Ababa – Etiopía

Correo-e: itu-addis@itu.int

Tel.: +251 11 551 4977

Tel.: +251 11 551 4855

Tel.: +251 11 551 8328

Fax: +251 11 551 7299

Camerún

Union internationale des
télécommunications (UIT)

Oficina de Zona

Immeuble CAMPOST, 3^e étage

Boulevard du 20 mai

Boîte postale 11017

Yaoundé – Camerún

Correo-e: itu-yaounde@itu.int

Tel.: +237 22 22 9292

Tel.: +237 22 22 9291

Fax: +237 22 22 9297

Senegal

Union internationale des
télécommunications (UIT)

Oficina de Zona

19, Rue Parchappe x Amadou

Assane Ndoye

Immeuble Fayçal, 4^e étage

B.P. 50202 Dakar RP

Dakar – Senegal

Correo-e: itu-dakar@itu.int

Tel.: +221 33 849 7720

Fax: +221 33 822 8013

Zimbabue

International Telecommunication
Union (ITU)

Oficina de Zona de la UIT

TelOne Centre for Learning

Corner Samora Machel and

Hampton Road

P.O. Box BE 792 Belvedere

Harare – Zimbabwe

Correo-e: itu-harare@itu.int

Tel.: +263 4 77 5939

Tel.: +263 4 77 5941

Fax: +263 4 77 1257

Américas

Brasil

União Internacional de
Telecomunicações (UIT)

Oficina Regional

SAUS Quadra 06, Bloco "E"

11^o andar, Ala Sul

Ed. Luis Eduardo Magalhães (Anatel)

70070-940 Brasília, DF – Brazil

Correo-e: itubrasilia@itu.int

Tel.: +55 61 2312 2730-1

Tel.: +55 61 2312 2733-5

Fax: +55 61 2312 2738

Barbados

International Telecommunication
Union (ITU)

Oficina de Zona

United Nations House

Marine Gardens

Hastings, Christ Church

P.O. Box 1047

Bridgetown – Barbados

Correo-e: itubridgetown@itu.int

Tel.: +1 246 431 0343/4

Fax: +1 246 437 7403

Chile

Unión Internacional de
Telecomunicaciones (UIT)

Oficina de Representación de Área

Merced 753, Piso 4

Casilla 50484 – Plaza de Armas

Santiago de Chile – Chile

Correo-e: itusantiago@itu.int

Tel.: +56 2 632 6134/6147

Fax: +56 2 632 6154

Honduras

Unión Internacional de
Telecomunicaciones (UIT)

Oficina de Representación de Área

Colonia Palmira, Avenida Brasil

Ed. COMTELCA/UIT, 4.^o piso

P.O. Box 976

Tegucigalpa – Honduras

Correo-e: itutegucigalpa@itu.int

Tel.: +504 22 201 074

Fax: +504 22 201 075

Estados Árabes

Egipto

International Telecommunication
Union (ITU)

Oficina Regional

Smart Village, Building B 147, 3rd floor

Km 28 Cairo – Alexandria Desert Road

Giza Governorate

Cairo – Egipto

Correo-e: itucairo@itu.int

Tel.: +202 3537 1777

Fax: +202 3537 1888

Asia-Pacífico

Tailandia

International Telecommunication
Union (ITU)

Oficina de Zona

Thailand Post Training Center ,5th floor

111 Chaengwattana Road, Laksi

Bangkok 10210 – Tailandia

Dirección postal:

P.O. Box 178, Laksi Post Office

Laksi, Bangkok 10210, Tailandia

Correo-e: itubangkok@itu.int

Tel.: +66 2 575 0055

Fax: +66 2 575 3507

Indonesia

International Telecommunication
Union (ITU)

Oficina de Zona

Sapta Pesona Building, 13th floor

Jl. Merdan Merdeka Barat No. 17

Jakarta 10001 – Indonesia

Dirección postal:

c/o UNDP – P.O. Box 2338

Jakarta 10001 – Indonesia

Correo-e: itujakarta@itu.int

Tel.: +62 21 381 3572

Tel.: +62 21 380 2322

Tel.: +62 21 380 2324

Fax: +62 21 389 05521

Países de la CEI

Federación de Rusia

International Telecommunication
Union (ITU)

Oficina de Zona

4, Building 1

Sergiy Radonezhsky Str.

Moscú 105120 – Federación de Rusia

Dirección postal:

P.O. Box 25 – Moscú 105120

Federación de Rusia

Correo-e: itumoskow@itu.int

Tel.: +7 495 926 6070

Fax: +7 495 926 6073

Europa

Suiza

Union internationale des
télécommunications (UIT)

Oficina de Desarrollo de las
Telecomunicaciones (BDT)

Unidade Europa (EUR)

Place des Nations

CH-1211 Ginebra 20 – Suiza

Correo-e: eurregion@itu.int

Tel.: +41 22 730 5111



Unión Internacional de Telecomunicaciones
Oficina de Desarrollo de las Telecomunicaciones

Place des Nations
CH-1211 Ginebra 20

Suiza
www.itu.int