

FINAL REPORT  
ITU-D STUDY GROUP 2

# QUESTION 10-3/2

## TELECOMMUNICATIONS/ ICTS FOR RURAL AND REMOTE AREAS



5TH STUDY PERIOD 2010-2014  
Telecommunication Development Sector



## **CONTACT US**

Website: [www.itu.int/ITU-D/study\\_groups](http://www.itu.int/ITU-D/study_groups)  
ITU Electronic Bookshop: [www.itu.int/pub/D-STG/](http://www.itu.int/pub/D-STG/)  
e-mail: [devsg@itu.int](mailto:devsg@itu.int)  
Telephone: +41 22 730 5999

## **QUESTION 10-3/2:**

***Telecommunications/ICTs for rural  
and remote areas***



## **ITU–D Study Groups**

In support of the knowledge sharing and capacity building agenda of the Telecommunication Development Bureau, ITU–D Study Groups support countries in achieving their development goals. By acting as a catalyst by creating, sharing and applying knowledge in ICTs to poverty reduction and economic and social development, ITU–D Study Groups contribute to stimulating the conditions for Member States to utilize knowledge for better achieving their development goals.

### **Knowledge Platform**

Outputs agreed on in the ITU–D Study Groups and related reference material are used as input for the implementation of policies, strategies, projects and special initiatives in the 193 ITU Member States. These activities also serve to strengthen the shared knowledge base of the membership.

### **Information Exchange & Knowledge Sharing Hub**

Sharing of topics of common interest is carried out through face–to–face meetings, e–Forum and remote participation in an atmosphere that encourages open debate and exchange of information.

### **Information Repository**

Reports, Guidelines, Best Practices and Recommendations are developed based on input received for review by members of the Groups. Information is gathered through surveys, contributions and case studies and is made available for easy access by the membership using content management and web publication tools.

### **Study Group 2**

Study Group 2 was entrusted by WTDC–10 with the study of nine Questions in the areas of information and communication infrastructure and technology development, emergency telecommunications and climate–change adaptation. The work focused on studying methods and approaches that are the most suitable and successful for service provision in planning, developing, implementing, operating, maintaining and sustaining telecommunication services which optimize their value to users. This work included specific emphasis on broadband networks, mobile radiocommunication and telecommunications/ICTs for rural and remote areas, the needs of developing countries in spectrum management, the use of ICTs in mitigating the impact of climate change on developing countries, telecommunications/ICTs for natural disaster mitigation and relief, conformance and interoperability testing and e–applications, with particular focus and emphasis on applications supported by telecommunications/ICTs. The work also looked at the implementation of information and communication technology, taking into account the results of the studies carried out by ITU–T and ITU–R, and the priorities of developing countries.

Study Group 2, together with ITU–R Study Group 1, also deals with Resolution 9 (Rev. WTDC–10) on the “Participation of countries, particularly developing countries, in spectrum management”.

This report has been prepared by many experts from different administrations and companies. The mention of specific companies or products does not imply any endorsement or recommendation by ITU.

## Table of Contents

	<i>Page</i>
<b>1 General .....</b>	<b>1</b>
<b>2 Introduction.....</b>	<b>2</b>
2.1 Landlocked areas .....	3
2.2 Mountainous villages.....	3
2.3 Isolated remote islands in SIDS.....	3
2.4 Isolated villages in vast countries (desert, forest, no social infrastructure, etc.).....	4
<b>3 Challenges for the development of telecommunications/ICTs in rural and remote areas .....</b>	<b>4</b>
3.1 Introductory background.....	4
3.2 Challenges for telecommunications/ICTs/broadband development in rural and remote areas.....	4
<b>4 Telecommunications/ICTs services/applications/contents, benefits/ importance, and impacts of connecting unserved population .....</b>	<b>9</b>
4.1 Background .....	9
4.2 Categorization of applications and services .....	10
4.3 E–applications.....	11
4.4 Applications vital and important for rural and remote areas.....	12
4.5 Contents.....	14
4.6 Speed requirements for different applications .....	15
4.7 Importance and impact of connecting the unconnected .....	16
<b>5 Assessment of backhaul and access technologies for connecting rural and remote areas .....</b>	<b>16</b>
5.1 Optic fiber technology .....	16
5.2 Topologies for optical user access .....	16
5.3 Technical characteristics of P2P optical access and PON .....	18
5.4 Topologies for optical backhaul.....	20
5.5 Terrestrial wireless technologies .....	23
5.6 Technologies for connecting remote areas and rural communities.....	26
<b>6 Summary of the relevant contributions including case-library and e-discussion forum.....</b>	<b>35</b>
<b>7 Selected country case studies .....</b>	<b>35</b>
7.1 Satellite broadband supporting elections in Burkina Faso (Burkina Faso/SES World Skies (Netherlands)).....	36
7.2 Argentina Conectada (Argentina Connected)(Argentina) .....	36
7.3 Satellite connectivity plan for rural schools in Argentina (Argentina).....	37

	<i>Page</i>
7.4 Livelihood opportunities and cultural preservation through a sustainable and eco-friendly ICT telecenter (Marshall Islands) .....	38
7.5 Mobile WiMAX in Japan (Japan) .....	39
7.6 Pilot project for the improved health & medical environment with ICT for rural areas in Lao P.D.R. (Lao P.D.R./Japan) .....	39
7.7 APT J3 Project: Pilot installation of tele-center for remote education and health-care in rural areas and isolated islands in Micronesia (Micronesia/Japan) .....	40
7.8 Telecommunications/ICT development by ad-hoc communications network for rural Shiojiri City in Nagano prefecture, Japan (Japan) .....	40
7.9 Mobile Health Information System: Providing access to information for healthcare workers (Project in South Africa /Qualcomm Inc (United States) ) .....	41
7.10 Mobile microfranchising and AppLab initiatives (Project in Indonesia /Qualcomm Inc (United States)) .....	42
7.11 Rural and remote areas (Madagascar) .....	42
7.12 Provision of basic telephone services for rural areas (Togo).....	42
7.13 Project of terrestrial wireless broadband connectivity (Burundi) .....	43
7.14 Rural ICT Development Project in Iran (Iran).....	44
7.15 Energy effective and low cost technology for wireless broadband access and GSM cellular networks (OJSC Intellect-Telecom (Russian Federation).....	44
7.16 The Mawingu Project: Providing broadband access using TV White Spaces in rural Kenya (Project in Kenya/Microsoft Corporation(United States)).....	45
7.17 Evaluating different access technology options (Egypt).....	45
7.18 WiMAX and FiberWiFi Broadband in Rural Areas of Bhutan (Bhutan).....	45
7.19 Fishing with 3G Nets (Project in Brazil/Qualcomm Inc (United States)).....	46
7.20 Let's Get Ready! Mobile Safety Project (Project in P.R. China/Qualcomm Inc (United States)).....	46
7.21 WLAN Coverage solutions in rural China (P.R. China) .....	46
7.22 Innovative technological solution for broadband use in rural areas – Data Rural Application Exchange (D-Rax from C-DoT) (India).....	47
7.23 Successful e-initiative for rural people in remote North Eastern part of India – Active community participation for sustainability (India) .....	47
7.24 Case Studies from Broadband Commission Reports .....	47
7.25 Analysis of selected case studies .....	49
7.26 List of technologies, applications and funding in ITU-D SG2 Q10-3/2 case studies.....	51
<b>8 Conclusions and Recommendations .....</b>	<b>53</b>
<b>9 Acronyms and abbreviations .....</b>	<b>56</b>
<b>10 References .....</b>	<b>58</b>

	<i>Page</i>
<b>Annexes</b>	
<b>Annex 1: List of input contributions during the study period 2010-2014 and their summaries .....</b>	<b>63</b>
<b>Annex 2: Analysis of questionnaire replies for the global survey on policy initiatives/ interventions on telecommunications/ICTs/broadband development .....</b>	<b>86</b>
<b>Figures and Tables</b>	
Figure 1: World population trends, rural vs. urban.....	2
Figure 2: Topologies for optical user access.....	17
Figure 3: Example of geostationary satellite backhauling network .....	33
Figure 4: Example of medium-earth orbit satellite backhauling network .....	33
Figure 5: Example of dynamic spectrum access-based solution .....	34
Table 1: Application speed requirement levels.....	15
Table 2: Application completion times at different connection speeds .....	15
Table 3: Advantages and drawbacks of P2P optical access and PON.....	20
Table 4: Advantages and drawbacks of optical technology in backhaul.....	21
Table 5: Possible solutions for point to point (PTP) microwave links and Point to Multi-Point (PMP) solutions. ....	25
Table 6: List of technologies, applications and funding in ITU-D SG2 Q10-3/2 case studies .....	51





## QUESTION 10-3/2

# Telecommunications/ICTs for rural and remote areas

### 1 General

ITU–D Study Group 2 Question 10–3/2 and its mandate were agreed by WTDC–10 (Hyderabad, India). The title of the Question is slightly modified from previous study period with the addition of “ICTs”. The Question stressed the importance of providing broadband communications to rural and remote areas. The question of studying the provision of communications to rural and remote areas goes back to WTDC–94 (Buenos Aires, Argentina) when it was agreed in the Buenos Action Plan (BAP–94) as Question 4/2 communications for rural and remote areas. The same title of the Question was also adopted by the Valletta Action Plan (VAP–98) of WTDC–98 (Valletta, Malta). It was agreed to study the following items:

- Communications for rural and remote areas
- Development of multi–purpose community telecentres
- Penetration and service targets for rural telecommunications
- Definition of a set of indicators describing the state of development of a country’s rural telecommunication network and services
- Sound and television broadcasting and communication for rural and remote areas
- Measurement of the impact of information and communication technologies in rural and remote areas
- Enhancing the capacity of non–governmental organizations (NGOs) to achieve development aims, through the use of telecommunications

This Question was also continued in the Istanbul Action Plan (IsAP–2002) of WTDC–02 (Istanbul, Turkey) as Q10–1/2. Then Doha Action Plan (DAP–2006) by WTDC–06 (Doha, Qatar) agreed to slightly modify the title as Q10–2/2 “Telecommunications for rural and remote areas”. The mandate of the present Question 10–3/2 is summarized as follows;

**Step 1** – identification of techniques and solutions that can significantly impact on the provision of telecommunication/ICT applications for rural and remote areas, etc.

**Step 2** – to continue to investigate and report on how the techniques identified above can deliver services and applications to rural and remote areas.

**Step 3** – to identify, assess and consolidate challenges of developing countries in setting up the low cost sustainable telecommunications infrastructure in the rural and remote areas

**Step 4** – to describe the evolution of system requirements for rural network system specifically addressing such identified challenges of rural deployment.

**Step 5** – to continue consideration of the sustainability of the techniques and solutions identified in the above–mentioned steps.

**Step 6** – to augment the report on the range of case studies that clearly demonstrate how a range of techniques, based on new technology aimed at providing reduced capital and operating cost solutions, reducing (GHG) emissions and enhancing community participation, can maximize the benefits of broadband telecommunication/ICT infrastructure in rural and remote areas.

To meet the above mentioned mandate of the Question, contributions (for action and information) and case studies were submitted by Member States, Sector Members, Associates and Academia members to the Study Group meetings and Rapporteur’s Group meetings during the study period as shown in the

**Annex 1** to the report and in the ITU-D Case Study Library ([https://extranet.itu.int/itu-d/studygroups\\_caselib/Lists/Case%20Library%20Documents/AllItems.aspx](https://extranet.itu.int/itu-d/studygroups_caselib/Lists/Case%20Library%20Documents/AllItems.aspx)).

The World Summit on the Information Society (WSIS) (Geneva, 2003) Geneva Plan of Action sets the goal to provide internet available for all on this planet by 2015. Almost half of the global population is said to be in the rural areas according to the statistics of United Nation’s Population Division (2009) as shown in Figure 1.

According to the Little Data Book (LDB) published 2012 by World Bank and ITU, there are globally over 6 billion mobile phone subscriptions, but 2/3 of the world’s population still remain offline. Individuals using internet amounted to 2.4 billion and the number of fixed (wired)–broadband subscriptions reached almost 600 million. Broadband mobile penetration is limited. On the other hand, smartphone users are growing rapidly in developing countries. The challenges related to broadband infrastructure development in rural and remote areas are a reality in many countries. This report is compiled from the input and contributions from ITU Member States, Sector Members, Associates and Academia members and case studies to respond to the set mandate.

**Figure 1: World population trends, rural vs. urban**

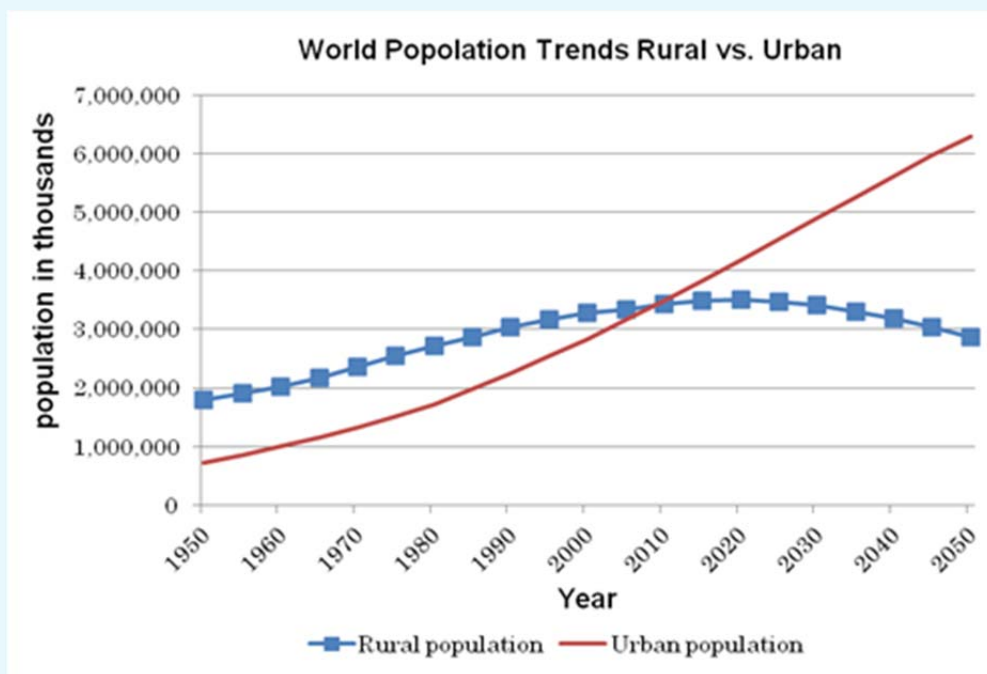

Source: UNDP, 2009.

## 2 Introduction

The Rapporteur Group studied the Question through the contributions, and case studies from the membership and through discussions on e-Forum on the ITU-D website and the Broadband Commission Reports. The study focused on cost effective technologies, applications and solutions to be deployed for the development of rural and remote areas. Socio-economic effects of the telecommunications development are also studied by analyzing the case studies collected during this study period and previous study periods. The E-forum for Q10-3/2 debated the definition of “rural and remote areas”. Also discussed was the minimum requirement of broadband to be applicable for providing various telecommunications/ICTs/broadband services for the rural and remote areas were debated and there were comments saying that it should be at least 256/512 Kbps (upward/downward). The Broadband Commission, jointly launched by ITU and UNESCO, discussed the definition of “Broadband” in its report.

The Broadband Commission report mentions that it is difficult to define a particular speed as “Broadband” since the requirement is changing rapidly depending on the emerging services and applications.

During the study period, a questionnaire was circulated by BDT to administrations to survey the status in Member States with regards to the development of telecommunications/ ICTs/broadband for rural and remote areas. Several countries responded with their input about the different data speed targets including a download speed of 2Mbps for rural areas.

The Group collaborated closely with ITU–D Study Group 1 Questions 7–3/1, 22–1/1, 24/1 and Study Group 2 Question 25/2 as stated in the mandate of the Question.

Rural and remote areas under the study of ITU–D Question 10–3/2 are defined as areas that are away from large cities or towns and mostly not heavily populated in comparison with urban and suburban areas. In some countries, such areas are defined as areas which have population of less than 2500 inhabitants. Rural areas depend significantly on agricultural activity and may be characterized by the following:

- 1) Geographic access problems due to distance, terrain, poor quality of road/transport network and remoteness of some rural communities;
- 2) Lack of or inadequate basic enabling infrastructure such as regular electricity supply;
- 3) Absence of adequate telecommunications infrastructure;
- 4) Cost of physical access and equipment installation due to any combination of the above geographically related issues;
- 5) Low geographic density of target population (i.e. small village populations, in sparsely populated communities that are geographically separated from one another);
- 6) Low income, lack of disposable income and relative poverty of rural population;
- 7) High degrees of illiteracy in some rural areas;
- 8) Low levels of awareness (if any) of the benefits of modern telecommunications leading to low current demand in some areas;
- 9) Overall lack of funding (both public and private);
- 10) Others.

The following specific rural and remote areas in the developing countries are underserved and left behind from modern telecommunication/ICT services.

## **2.1 Landlocked areas**

Landlocked developing areas are enclosed or nearly enclosed by the land and suffer from lack of territorial access to the sea, remoteness and isolation from the market. The high transit costs impose serious constraints on the socio economic development. These harsh terrains have significant impact on building of telecommunications infrastructure providing telecommunication/ICT services to those areas.

## **2.2 Mountainous villages**

There are mountainous villages where villagers are dwelling sparsely on the slopes of mountains, ridges and hills in cluster scattered over from one valley to another. There are Himalayan mountain villages in South Asia and others in Latin America or elsewhere. Building telecommunications infrastructure and its maintenance in these areas impose high costs and revenue on investment tends to be limited making service provision less lucrative for the telecommunication/ICTs service providers.

## **2.3 Isolated remote islands in SIDS**

Small Islands Developing States (SIDS) are recognized as a distinct group of developing countries facing specific social, economic and environmental vulnerabilities at the United Nations Conference on Environment and Development (UNCED), also known as the Earth Summit, held in Rio de Janeiro, Brazil

(3–14 June 1992). The United Nations recognizes the 38 UN Member States belonging to the Alliance of Small Island States (AOSIS), an ad hoc negotiating body established by SIDS at the United Nations. Three geographical regions have been identified for the location of SIDS, namely, the Caribbean, the Pacific and the Atlantic, Indian Ocean, Mediterranean and South China Sea (AIMS). SIDS tend to confront similar constraints in their sustainable development efforts, such as a narrow resource base depriving them of the benefits of economies of scale; small domestic markets and heavy dependence on a few external and remote markets; high costs for energy, infrastructure, transportation, communication and servicing. Connectivity to remote islands may be provided by satellite links or optic fiber cables rather than by terrestrial transmission medium.

## **2.4 Isolated villages in vast countries (desert, forest, no social infrastructure, etc.)**

There are isolated villages scattered over the desert and forest in the vast countries of ITU regions of the world. These villages are geographically separated by far distance in remote areas and difficult to access terrestrially. There may not be access road to these villages nor terrestrial access network infrastructure to be constructed except via satellite link. To provide connectivity cost effectively to these areas is the challenge by choosing appropriate technologies but the needs for the Telecommunications/ICTs are high for the quality of their lives of the dwellers.

Therefore, it is proposed to deal with the challenges and requirements of system and equipment for fixed and mobile networks for multimedia ICT services for above mentioned rural and remote areas in developing countries. Many of the problems facing rural areas are outside the scope of telecommunications alone to resolve and require the necessary co-ordination of rural electrification, transport network development, education and training programmes.

There is a need to design more cost effective technology solutions for rural areas with the needs and economies of rural communities in mind.

## **3 Challenges for the development of telecommunications/ICTs in rural and remote areas**

### **3.1 Introductory background**

The socio-economic and infrastructure development indicators in the rural and remote areas of most of the developing and Least Developed Countries (LDCs) remain miserable. Once we understand the underdevelopment of rural and remote areas, the interrelated challenges associated with telecommunications/ICT sector development in such areas can also be easily understood as this has direct or indirect impact on the development of telecommunications/ICTs/broadband in such areas.

### **3.2 Challenges for telecommunications/ICTs/broadband development in rural and remote areas**

There are numerous challenges for the development of telecommunications/ICTs/broadband in rural and remote areas. These challenges have been presented from the perspective of the elements in entire telecommunications/ICTs /broadband ecosystem. In this report , we have identified the government, the regulator, the telecom service providers, the customer premises equipment (CPE) manufacturers, the infrastructure manufacturer (vendors), the Value Added Service (VAS) providers, the content developers, the bilateral and multilateral donor agencies, the civil society organizations, the consumers as the major stakeholders in the telecommunications/ICTs/broadband value chain.

Even with competition and good use of public resources such as radio-frequency spectrum and rights of way, the cost of making substantial advances in connectivity can remain a significant barrier to rapid private-sector investment. Also, competition might even weaken some means of reaching universal service objectives. In the past, incumbents' internal cross-subsidies from certain services allowed the

belowcost provision of standard telephony in rural and low-income areas. Competition may eventually drive coverage beyond the more profitable areas. A clear regulatory plan should however, take account of the tendency of some operators to “cherry pick” only the most attractive markets.

A common approach to the loss of internal cross-subsidies is to institute universal access charges that supply a fund that may be used for reverse subsidy auctions. Other geographic-focused solutions include region-specific approaches to licensing, exemptions from licence and spectrum fees, encouraging partnerships among operators, and coupling profitable areas with under-served rural areas in licences.

It is also necessary to encourage the construction of supporting backbone networks, especially if the intent is to deploy infrastructure into rural areas.

### **3.2.1 Policy, legal and regulatory perspectives**

Strong policy leadership to catalyze broadband adoption through orchestrating plans and enabling investment does not have to mean active government build out and operation. In most cases, private firms build and operate networks more efficiently. Governments should consider direct investment only in cases of market failure such as in rural areas where financial returns are low or non-existent.

Countries should take care to ensure that national targets do not become a blunt tool that can fail to take into account the needs and geography of certain areas (e.g. for remote or rural areas). Targets also need to remain relevant and realistic, rather than abstract and overly ambitious.

Public-private partnerships (PPPs) can help drive the deployment of broadband, particularly in rural and underserved areas. Efforts should be renewed to mobilize public and private support for a significant improvement of basic ICT infrastructure in countries where such infrastructure is most lacking, as well as in rural and remote areas, and for disadvantaged groups. In this regard, the particular suitability of special solutions such as mobile broadband and the potential offered by satellite systems with strong fibre optic backhaul to serve LDCs and other countries in special need should be noted.

An economic analysis relevant to rural and remote areas, and disadvantaged groups should be undertaken to determine sustainable business models for adequate returns on broadband investment at minimum income levels with maximum spill-over benefits across multiple sectors of the local society and economy. The same applies to rural and remote areas, and disadvantaged groups. The innovative use of ‘digital dividends’ should be considered.

In a market-led approach, however, incentives need to be designed and given to rolling out infrastructure to ensure that telecommunication networks with high fixed costs extend beyond profitable urban areas to include rural communities as well. Otherwise, success in deploying broadband networks may be only partial at best, excluding rural populations and many of those in greatest need.

It has been established by practices and experiences that sole reliance on market forces for the development, expansion and diversification of telecommunication/ICTs/broadband infrastructure and services in the rural and remote areas simply does not work. Specific policy, legal and regulatory interventions seem to be inevitable for the governments and the regulators. But in the developing and LDCs, the government always finds it difficult to arrange for the capital intensive fund required for such purpose. The governments have more pressing needs to allocate the available fund for important priority areas such as health, education, security and law and order. Due to the lack of appropriate economic and business models and the know-how on international best practices, the government and the regulator could not come up with a workable modality. In a liberalized market while formulating license conditions for private operators, obligations to provide service in rural and remote areas could be implemented. The collection and timely disbursement of Universal Service Obligation (USO) funds to provide infrastructure and services could be implemented. Incentive regulation can be developed. An asymmetrical interconnection charge could be implemented. Infrastructure sharing could be implemented to avoid investment duplication.

There are a number of different international practices. It is a challenge for the government and the regulator to come up and implement some workable modality for rural and remote areas depending on a country specific context. The time passes by. The government does not have any policy, legal and regulatory framework and even if such loose framework exists, the implementation remains dysfunctional or weak and people in the rural and remote areas are deprived of the most coveted and sought after telecommunications/ICTs/broadband services. Governments should fully utilize the telecommunications/ICTs/broadband for uplifting the socio-economic status of the rural and remote areas. It needs a plan and program.

Policies to expand infrastructure into more economically marginal areas are based on the recognition that without such access, the digital divide will continue and could grow – both between developing and developed nations and between urban and rural areas. Regulators play a critical role in seeking to reduce this divide through the promotion of broadband access.

**Regulators have several ways to address the true access gap, including:** Licensing special rural operators to deploy broadband networks in defined locations. Licensees can be selected through bidding for the minimum subsidy required to achieve specified targets. By this method, regulators can accelerate the diffusion of new technologies from urban to rural areas.

Giving direct and indirect financial support in return for the deployment of broadband networks: Governments can provide tax exemptions to operators that roll out infrastructure in rural areas. Where this is insufficient to attract commercial operators, governments could offer full or partial subsidies, or loans at preferential rates.

**Consistent licensing and authorization frameworks:** While licences — or at least general authorizations — are usually required for large-scale broadband infrastructure operators, regulators are increasingly lightening such requirements for operators and service providers in small, remote and rural areas. Facilitating broadband market entry in these areas allows providers to test their broadband business models on a small scale. Some may later decide to commit to more large-scale deployment.

Where broadband access will be used exclusively for public services, such as in health facilities or schools, regulators may question whether licensing should apply at all. It is also particularly important that licence fees for very small broadband providers be kept as low as possible, if not eliminated altogether. In rural areas too, a case can be made for allowing resale of broadband services without any licensing requirements. For example, broadband subscribers in a rural area could be allowed to use their connections to set up public kiosks and resell the service. The customers of these kiosks might not otherwise be able to afford the service at all.

**Technology neutrality:** Technology- and service-neutral licences and authorizations also enable broadband providers to offer a full range of services in rural areas (including multiple play), increasing revenue stream options. In Venezuela, for example, rural licences allow operators to offer mobile and multimedia services in addition to fixed access, long-distance and international services.

**Optimizing the use of radio-frequency spectrum:** Indiscriminate reallocation of frequencies could result in reduced options for inhabitants of rural areas, and special attention should be given to helping developing countries in addressing optimal policies in this field.

**Infrastructure sharing and open access:** Deploying mobile base stations or fibre backbone networks to reach rural areas may be uneconomical if each company builds its own infrastructure. Companies can, however, share some infrastructure but, at the same time, compete in providing services.

**Responding to the broadband challenge:** Regulators clearly face numerous challenges in the broadband context. In particular, they face a perceived lack of local demand and available revenue streams for broadband in many countries. This could delay the commercial deployment of broadband access networks — especially rural areas — at least by large-scale network operators.

Some of the options open to regulators are as follows:

- A regulatory framework tailored to small broadband providers will enable and encourage local community providers to harness the potential of broadband technologies and enable greater broadband access in rural areas;
- Competitive large-scale operators can be encouraged to extend their networks to rural areas through infrastructure-sharing arrangements that guarantee open access to all competitive operators;
- Competitive large-scale operators can be given incentives to deploy networks in return for appropriate rewards;
- Regulators could seek to encourage the deployment of broadband access networks by providing direct, targeted subsidies from universal access funds or indirect financial benefits (such as tax exemptions) to a full range of broadband providers.

### **3.2.2 Operators' perspectives**

From the operator's point of view, investment in rural telecom should ensure a sound business case: a sustainable and viable business. The following poses additional problems and challenges for the telecom service providers and divert their attention from their core business. These includes inter alia:

- Lack of transportation facility to the targeted sites– no roads, no air routes.
- Lack of electricity supply from the national grid and even if available it is partial due to load shedding and also for connecting their infrastructure to the power grid.
- Inability to choose appropriate technology at the right.
- Investment in the wrong technology.
- Government/regulator's delay in assignment of right kind of spectrum at right time.
- Non-availability of backhaul.
- Scattered and isolated settlement characteristics of the rural households.
- Cost based tariff would become unaffordable for rural consumers.
- Collection of telecom service bills for postpaid mode would be difficult.
- Demand creation is difficult due to low level of literacy and awareness of the use and applications of telecom services and devices by the rural population.
- The parameters for investment decisions such as the Average Revenue per User (ARPU), Return on Investment (ROI), Internal Rate of Return (IRR) and payback period are not favorable for the operators. The ARPU is expected to be low in rural areas. ROI is also likely to be lower. Payback period is likely to be longer. There is a risk of the technology deployed to be obsolete before it pays back. For high utilization of the limited fund, per subscriber cost of investment needs to be low, which is unlikely in rural areas.
- Delayed permissions for Right of Way such as for laying optical fiber cables, erecting towers at strategic points etc.
- No single window service for permissions–time wasted moving from one government department to another for permissions– be it for equipment import or for getting permission for right of way or for payment in foreign currency.
- Lack of qualified human resources.
- Long Restoration and Maintenance of the sites.

### **3.2.3 Consumers' perspectives**

Consumers want telecom services to be available, affordable and of good quality. In rural areas the following challenges are rampant from the perspectives of the consumers:

- Higher cost of the services;
- Not easily accessible and available;
- Inferior quality even if available;
- Lower literacy and lack of awareness does not allow the rural consumers to fully make use of the available services;
- Cannot afford advanced devices due to cost factor even if they know how to make use of such devices;
- Non availability of electrical power causes problems for charging their devices needing low power consuming devices and higher battery life;
- Non availability of user friendly devices– devices having local language and contents etc.

### **3.2.4 Vendors' perspectives**

Vendors have been challenged from the rural perspectives in many different ways. They include but not limited to the following:

- Designing of low weight low foot print;
- Designing of low power devices and infrastructure capable of tolerating power fluctuations;
- Designing of outdoor equipment rugged enough to work under the impact of environmental factors, and protected to endure mishandling and requiring low maintenance;
- Conformance to green requirement;
- Innovation in technology for efficient access and bandwidth efficient backhaul network design;
- Huge investments in research and development (R&D) to achieve all these requirements.

### **3.2.5 CPE manufacturers' perspectives**

The customer premises equipment (CPE) manufacturers should be innovative enough to design

- Low cost;
- Low power;
- Light weight;
- User friendly;
- Local language enabled;
- Differentially abled people friendly, such as blind– and deaf–friendly.

### **3.2.6 Content developers' perspectives**

A study has shown that in a typical developing country, a growth in tele–density by 10% increases the GDP by 0.6%. Similarly a growth of broadband by 10% increases the GDP by 1.38%. For the rural subscribers to take the benefit of being connected, the challenge lies in creating killer applications/information/contents that will be used by the rural population and contribute to socio– economic growth. Developing services like e/m–education, e/m –health, e/m –government services will certainly add to socio–economic values to the users of telecom services. Differentially abled people friendly –such as blind and deaf software applications and content development can add value to the society. Developing such services and creating demand by the prospective service seekers is a challenge for the content developers.



### **3.2.7 International organizations and bilateral and multilateral donor agencies' perspectives**

Significant donor agency involvement has been witnessed for the advancement of socio-economic and human development activities as well as for infrastructure development in rural areas of developing and least developed countries. It is a fact that these efforts have been supply-driven rather than demand-driven. These efforts have been isolated rather than taking an integrated and holistic approach.

Donor harmonization is needed, which would need to look into developing the essential infrastructures, while talking about the provision of telecommunications/ICTs/broadband services in the rural and remote areas. They should also understand that telecommunications/ICTs/broadband services provide the enabling environment for all other types of development. Harmonization, integration and coordination while developing any projects related to telecommunications/ICTs/broadband services between the donor and the government and between the donors has been a challenge resulting in duplication of works.

## **4 Telecommunications/ICTs services/applications/contents, benefits/importance, and impacts of connecting unserved population**

### **4.1 Background**

Digital divide exists not only between the developed and developing countries but also between the rural and urban areas within the countries. The divide also exists between the individuals and families based on their economic status and literacy. This exists between young and old people, between normal persons and persons with disability. The economic, literacy, age group and ability issues are more prominent in the rural and remote areas than urban areas.

Traditional methods of rural development approaches will not only be cost prohibitive but also will take a very long time to implement. That is where the developmental and quality of life aspirations of the rural population require state of the art telecommunications/ICTs/broadband interventions.

Many countries in the world are now considering construction of Information Superhighways in many rural communities. The information services, applications and contents carried over these new digital superhighways will no doubt transform rural economies as much as the interstate highway system and the railroads changed rural communities in earlier times. It is obvious that national economies in almost all the countries in the world would not be able to support bringing railroads and multi-lane interstate freeways to every rural community. However, it has become economically feasible for every rural community all over the world, no matter how remote, to have good access to the information highways of the twenty-first century due to the advancement in technologies particularly, the wireless technologies. Some communities will have better access or have it sooner. It is also evident that those rural communities with good access to the national and international information superhighways will have stronger local economies than those without good access.

Mobile broadband, fixed wireless broadband, and fixed wireless broadband services are emerging, however the penetration to the rural and remote areas will be taking more time. Allowing mobile operators to roam onto each other's second- and third-generation (2G and 3G) networks in rural areas could save significant network costs while enabling greater coverage. In some places competitors have also started sharing the bulk of their wireless access network facilities in non-rural areas: one example is Telstra's and Hutchison's shared 3G network in Australia. Similarly, France has allowed infrastructure sharing among 2G operators in order to reach unserved rural areas. Such roaming and infrastructure-sharing arrangements could also apply to new broadband wireless networks.

The WSIS Geneva Declaration of Principles says that "We, the representatives of the peoples of the world, assembled in Geneva from 10-12 December 2003 for the first phase of the World Summit on the Information Society, declare our common desire and commitment to build a people-centered, inclusive

and development-oriented Information Society, where everyone can create, access, utilize and share information and knowledge, enabling individuals, communities and peoples to achieve their full potential in promoting their sustainable development and improving their quality of life, premised on the purposes and principles of the Charter of the United Nations and respecting fully and upholding the Universal Declaration of Human Rights.”<sup>1</sup>

Geneva Plan of Action also identifies 11 Action Lines<sup>2</sup> which includes: the role of public governance authorities and all stakeholders in the promotion of ICTs for development; Information and communication infrastructure; access to information and knowledge; capacity building; building confidence and security in the use of ICTs; enabling environment; ICT applications including – E-government, E-business, E-learning, E-health, E-employment, E-environment, E-agriculture, E-science; cultural diversity and identity, linguistic diversity and local content; media; ethical dimensions of the Information Society; international and regional cooperation.

The Broadband Commission for Digital Development has been set up by ITU and UNESCO to step up the United Nation’s efforts to meet the Millennium Development Goals (MDGs). It is now possible to leverage the tremendous power of ICTs in the development agenda, to help accelerate progress towards meeting the MDGs – through e-health, e-education, e-government, e-agriculture and more.<sup>3</sup> Broadband finds applications in energy sector, healthcare, education, environment, transport networks and to accelerate progress towards the MDGs.<sup>4</sup> The Broadband Commission website is a single repository on international best practices for the use of ICTs/Broadband.

The rural and remote areas in many part of the world could not really get the access to the PSTN facility. However, access to mobile phones even in the rural and remote areas has been phenomenal. The voice services and low speed data services available through the mobile networks in the rural and remote areas have limited applications having transformative potentials offered by broadband networks. As has been witnessed across the ICT world, connectivity without content can make even the most sophisticated technologies irrelevant or of limited value. In today’s virtual world, it is vital that governments do not neglect the importance of content<sup>5</sup>.

## 4.2 Categorization of applications and services

Broadband applications broadly relating to improving quality of life, medical care, education, and governance could be categorized as:

- Video-based applications;
- Telehealth applications;
- Distance learning applications;
- E-government applications; and,
- Emergency management operations applications.

However, these application areas represent a small number of possible applications of broadband.

*Video-based applications.* Video transfer is a component in many different applications. Examples of entertainment-oriented applications include downloading media and online multiplayer games, and business-oriented applications include multi-point video conferencing.

*Downloading media.* Downloading movies and TV shows is big business.

---

<sup>1</sup> WSIS 2003, Geneva Declaration of Principles, [www.itu.int/wsis/documents/doc\\_multi.asp?lang=en&id=1161%7CO](http://www.itu.int/wsis/documents/doc_multi.asp?lang=en&id=1161%7CO)

<sup>2</sup> WSIS 2003, Geneva Plan of Action, [www.itu.int/wsis/documents/doc\\_multi.asp?id=1160%7CO&lang=en](http://www.itu.int/wsis/documents/doc_multi.asp?id=1160%7CO&lang=en)

<sup>3</sup> [www.broadbandcommission.org/about/background.aspx](http://www.broadbandcommission.org/about/background.aspx)

<sup>4</sup> Ibid.

<sup>5</sup> A 2010 Leadership Imperative: Future Built on Broadband; A report by the Broadband Commission.

*Online multiplayer video gaming.*

*Multi-point video conferencing.* Multi-point video conferencing refers to the sending and receiving of video and audio content from different locations simultaneously. This is different from end-to-end point single user video conferencing where there are only two end users communicating.

There are innumerable application services like e-commerce, e-education, e-health, gaming, video and audio streaming, stock quotes, news, cricket, tele-voting, chatting, astrology etc., which are provided over telecom networks. Each service differs in content, cost and demand and is customized for different segment of consumers. According to TRAI (India), applications can be primarily divided into following categories:<sup>6</sup>

- (i) Entertainment application services: Services like music, ringtones, videos&games are very popular and have contributed significantly to the growth of application services.
- (ii) Information application services: Services like e-education, e-health, news and information on bank account, real estate, education, travel, cricket etc. fall under information applications.
- (iii) Transactional application services: Enable customers to conduct transactions like banking and payment through phone.

### 4.3 E-applications

WSIS identifies a number of areas for e-applications and services in the Geneva Plan of Action from 2003. They are listed below for easy reference.<sup>7</sup>

- **E-government** focusing on applications aimed at innovating and promoting transparency in public administrations and democratic processes, improving efficiency and strengthening relations with citizens; adapted to the needs of citizens and business, to achieve a more efficient allocation of resources and public goods, to enhance transparency, accountability and efficiency at all levels of government.
- **E-business** to promote the benefits of international trade, to stimulate private sector investment, foster new applications, content development and public/private partnerships.
- **E-learning** to achieve universal education worldwide, through delivery of education and training of teachers, and offering improved conditions for lifelong learning, encompassing people that are outside the formal education process, and improving professional skills, to eradicate adult illiteracy; to promote e-literacy skills for all; targeting girls in the ICT education with the aim of increasing the number of women in ICT career.
- **E-health** for creating a reliable, timely, high quality and affordable health care and health information systems and for promoting continuous medical training, education, and research through the use of ICTs, while respecting and protecting citizens' right to privacy; to facilitate access to the world's medical knowledge and locally-relevant content resources for strengthening public health research and prevention programs and promoting women's and men's health, such as content on sexual and reproductive health and sexually transmitted infections, and for diseases that attract full attention of the world including HIV/AIDS, malaria and tuberculosis; to alert, monitor and control the spread of communicable diseases, through the improvement of common information systems; to promote the development of international standards for the exchange of health data, taking due account of privacy concerns; to improve and extend health care and health information systems to remote and underserved areas and vulnerable populations, recognizing women's roles as health providers in their families and communities; to provide medical and humanitarian assistance in disasters and emergencies.

---

<sup>6</sup> TRAI (India) Recommendations on Application Services, May,2012.

<sup>7</sup> WSIS Geneva Plan of Action, [www.itu.int/wsis/documents/doc\\_multi.asp?id=1160%7C0&lang=en](http://www.itu.int/wsis/documents/doc_multi.asp?id=1160%7C0&lang=en)

- **E–employment** to promote teleworking to allow citizens, particularly in the developing countries, LDCs, and small economies, to live in their societies and work anywhere, and to increase employment opportunities for women, and for those with disabilities
- **E–environment** to use and promote ICTs as an instrument for environmental protection and the sustainable use of natural resources; to initiate actions and implement projects and programmes for sustainable production and consumption and the environmentally safe disposal and recycling of discarded hardware and components used in ICTs; to establish monitoring systems, using ICTs, to forecast and monitor the impact of natural and man–made disasters, particularly in developing countries, LDCs and small economies.
- **E–agriculture** for the systematic dissemination of information using ICTs on agriculture, animal husbandry, fisheries, forestry and food, in order to provide ready access to comprehensive, up–to–date and detailed knowledge and information, particularly in rural areas; to maximize the use of ICTs as an instrument to improve production (quantity and quality).
- **E–science** for information and knowledge production, education and training, and to support the establishment of partnerships, cooperation and networking between universities and institutions; to promote electronic publishing, differential pricing and open access initiatives to make scientific information affordable and accessible in all countries on an equitable basis; to promote the use of peer–to–peer technology to share scientific knowledge and pre–prints and reprints written by scientific authors who have waived their right to payment; to promote the long–term systematic and efficient collection, dissemination and preservation of essential scientific digital data, for example, population and meteorological data in all countries; to promote principles and metadata standards to facilitate cooperation and effective use of collected scientific information and data as appropriate to conduct scientific research.

#### 4.4 Applications vital and important for rural and remote areas

##### 1) E–learning:

ICTs can contribute to achieving universal education worldwide, through delivery of education and training of teachers, and offering improved conditions for lifelong learning, encompassing people that are outside the formal education process, and improving professional skills. This applies to rural and remote areas as a necessity. Majority of the countries in the world have liberalized the education sector. We have witnessed education system established, supported and managed by the Government and public entities as well as educational institutions set up and managed by private entities. Due to peculiar characteristics of the public and private institutions, we have witnessed quality gap in these two types of system. This is more acute in case of rural and remote areas due to the fact that competent human resources have the least preference to work in such places. This divide can be bridged only through ICT interventions and E–learning/Mobile learning/e–education which are the popular methods.

The application of modern technological devices in particular personal computers, and thus with progressing technological development mobile phones, media players, game consoles and tablet PCs offers two major advantages for education and teaching. Firstly, it allows a scope of different media (text, pictures, graphs, audiofiles, and movies) to present learning content to the students. Secondly, in connection with standard or special software the students may actively use such content, modify it and therefore create new content. Internet connection allows easy access to a huge amount of information, both for teachers and learners, and it provides the infrastructure for various forms of communication at a distance via email, online chatting, as well as audio and video conferencing<sup>8</sup>.

---

<sup>8</sup> Laschewski, Lutz “Innovative E-learning in Rural Areas: A Review. Network Promoting e-Learning for Rural Development, e-Ruralnet, February 2013, on LLP Transversal Program Key Activity 3 ICT – Networks.

mLearning is especially meaningful in developing countries and in rural areas, where infrastructure is poor and access to resources may prove a challenge. mLearning provides anytime, anywhere educational content delivered via mobile technology.

The Millennium Village Project places education at the core of integrated rural development across sub-Saharan Africa. Building on the expertise of each partner, Connect To Learn identifies strategies to integrate teacher professional development with 21st century ICTbased teaching, tools and practices in classrooms.

Poor people, people living in rural areas, disabled people and other disadvantaged groups typically receive low-quality education, even though they have special educational needs. The challenge is to ensure that the introduction of ICT favours inclusive education and reduces inequalities.

Technology improves educational opportunities by enabling personalized study, while enhancing the potential for learning through community-based education and access to educational resources, even in remote rural schools.

While many countries have broadband policies in place and many Ministries of Education have called for broadband in all schools, progress towards reaching these goals is irregular and difficult to track, especially because many developing countries do not distinguish between connection types when collecting data related to ICT access and use. Several small Caribbean countries with concentrated populations, including Barbados, the British Virgin Islands, Saint Kitts and Nevis, Saint Lucia and Saint Maarten report that 100% of primary and secondary schools have fixed broadband connections (UIS, 2012). Uruguay has been able to provide fixed broadband to 95% of primary schools and 100% of secondary schools in both urban and rural subregions. For larger countries in the region, though, connectivity remains a challenge. For example, in Colombia 75% of primary and secondary schools are connected to the internet, but only 9% of all schools are connected via fixed broadband.

In spite of the progress made, barriers to broadband coverage still remain for developing countries. These obstacles include broadband costs, which are higher than in developed countries; accessibility, which is limited by a lack of cost-effective infrastructure and equipment, particularly in rural and remote areas.

The global teacher crisis is compounded by a lack of well-trained teachers and poor teacher training, especially in rural or remote areas. Broadband has the potential to give teachers access to high-quality teaching resources and collaborative professional development online.

## 2) E-health:

E-health is an emerging field in the intersection of medical informatics, public health and business, referring to health services and information delivered or enhanced through the Internet and related technologies. In a broader sense, the term characterizes not only a technical development, but also a state-of-mind, a way of thinking, an attitude, and a commitment for networked, global thinking, to improve health care locally, regionally, and worldwide by using information and communication technology<sup>9</sup>.

Studies have shown that there is a relation between the distribution of health care services in rural areas and the use of e-health<sup>10</sup>. The challenges in rural areas is manifest in the obvious geographic factors including isolation and small dispersed populations, limited public transport and road infrastructure, and the resultant, long distances to hospitals. There are also significant difficulties in recruiting qualified and experienced personnel in rural health care services. This is compounded by the increasing centralization of specialist secondary care services and the increase in the proportion of the elderly population relative

---

<sup>9</sup> Ibid.

<sup>10</sup> Myrvang, Robert and Rosenlund, Thomas, "How can e-Health benefit rural areas- a literature overview from Norway", Norwegian Centre for Telemedicine, April 2007

to the total population. The results from studies illustrates benefits or potential benefit of e-health systems to decrease rural migration by raised health care provision and by making employment in outlying areas more appealing for health care personnel.

Lack of access to health services is particularly acute for women in remote rural areas. Mobile technology can also be used to disseminate basic health and sanitary information to parents (such as vaccine reminders, and advice on maternal hygiene and nutrition); to train intermediary healthcare workers and rural doctors; to track disease and epidemic outbreaks; to monitor patients remotely; and to remind patients about the need to take medicines or come in for a check-up. There is an important and growing role for community centres with Internet access to deliver essential connectivity and health information, especially to women in rural and remote areas.

Broadband backbones connecting major hospitals can be used effectively to deliver lower-bandwidth services to local populations (such as basic monitoring or communications with outlying clinics in more rural areas). Simple services (such as SMS alerts, appointments or patient reminders) can be used effectively to improve the delivery of health services and reduce secondary costs (eg, the travel costs to remote clinics).

### 3) E-government:

E-government is the ways and means in which public sector institutions (governments) use information and communication technologies (ICT) to deliver services and information to the public. Examples of Services include but not limited to Payment of government taxes and utility bills online; Register change of address, births and marriages, deaths online; e-health services; E-education; E-election etc. Advances in e-government oriented technologies and services are taking place with a considerable speed around the world. E-government efforts aim to benefit from the use of most innovative forms of information technologies, particularly web-based Internet applications, in improving governments' fundamental functions. These functions are now spreading the use of mobile and wireless technologies and creating a new direction: mobile government (m-government)<sup>11</sup>. These services could be between government and government (G to G); between Government to Citizens (G to C) and between Government and Business (G to B) as well as between Business to Citizen (B to C).

## 4.5 Contents

Highlighting the importance of applications and contents, the National Broadband Plan released by the United States' Federal Communications Commission (FCC) in 2010 states that "ultimately, the value of broadband is realized when it delivers useful applications and content to end-users."<sup>12</sup>

Special emphasis has been given in WSIS Geneva Plan of Action 2003 for local content in action lines C8 under "Cultural diversity and identity, linguistic diversity and local content" especially to promote the production of cultural, educational and scientific content

- support local content development, translation and adaptation, digital archives, and diverse forms of digital and traditional media by local authorities
- provide content that is relevant to the cultures and languages of individuals through access to traditional and digital media services
- foster the creation of varied local and national content, including that available in the language of users

---

<sup>11</sup> From E-government to M-government: Facing the Inevitable; Ibrahim Kushchu, International University of Japan and M. Halid Kuscu, Southwestern College, School of Business and Information Systems

- nurture the local capacity for the creation and distribution of software in local languages, as well as content that is relevant to different segments of population, including non-literate, persons with disabilities, disadvantaged and vulnerable groups
- enhance the capacity of indigenous peoples to develop content in their own language

#### 4.6 Speed requirements for different applications

In the table below (Table 1) we list some of the speed requirements for different levels of services.

**Table 1: Application speed requirement levels**

Application	Level
E-mail of simple text files	Basic
E-mail of files with attachments two MBs and larger	Basic
Downloading small files (up to two MBs)	Basic
Online e-commerce	Mid-range
Asynchronous online presentations	Mid-range
End-to-end single user video conferencing	Mid-range
Remote access through virtual private network (VPN)s	Mid-range
Multi-end videoconferencing	Advanced
Telecommuting	Advanced
Distance learning	Advanced

Source: Columbia Telecommunications Corporation, 2010.

Table 2<sup>13</sup> examines applications based on the amount of time it takes to complete tasks efficiently with different connection speeds. This information is adopted from research conducted by the SBA into the bandwidth requirements for a number of business-oriented applications (using the categories of highly adequate, adequate, and not adequate) (Columbia Telecommunications Corporation, 2010).

**Table 2: Application completion times at different connection speeds**

Application	Network Download Speed			
	4 Mbps	10 Mbps	20 Mbps	50 Mbps
Multi-point video conferencing	Not Adequate	Adequate	Adequate	Adequate
Download high-definition video	Not Adequate	Not Adequate	Adequate	Highly Adequate
Server backup (one terabyte capacity)	Not Adequate	Not Adequate	Not Adequate	Highly Adequate
Telecommuting	Not Adequate	Not Adequate	Not Adequate	Highly Adequate
Distance learning	Not Adequate	Not Adequate	Not Adequate	Highly Adequate
Telemedicine	Not Adequate	Not Adequate	Not Adequate	Highly Adequate

Source: Columbia Telecommunications Corporation, 2010.

<sup>13</sup> [www.firstmonday.org/ojs/index.php/fm/rt/prINTERfriendly/4066/3355#tab2](http://www.firstmonday.org/ojs/index.php/fm/rt/prINTERfriendly/4066/3355#tab2)

#### 4.7 Importance and impact of connecting the unconnected

We have seen in the above paragraphs the potential of providing various types of services to the consumers. Each service caters to a particular requirement and has its own importance. From the perspectives of socio-economic development, capacity building of the rural population and government service delivery perspectives, not all services are equally important. We need to prioritize which services to be made available. We recommend that the governments should focus on e-education, e-health and e-government services as a priority. E-commerce could also be important to bring the rural population into mainstream financial systems.

In many emerging economies and rural areas, women remain economically and socially marginalized and under-educated, suffering from relatively poor employment prospects. ICTs and broadband are key to achieving empowerment and gender equality.

### 5 Assessment of backhaul and access technologies for connecting rural and remote areas

#### 5.1 Optic fiber technology

The optic fiber technology is used extensively in the modern world because its large capacity, low attenuation, small size, light weight, good performance of anti-interference, conservation on non-ferrous metals, as well as convenience in expansion. In the access segment, the introduction of triple play has led to the implementation of new technologies that have reduced costs and brought optical fiber through to the home. In backhaul, only topologies suitable for high speeds can be considered. Fibre-optic backbones can boost the capacity of digital subscriber line (DSL) networks. Extending fibre to rural areas can also facilitate Internet backhaul for wireless broadband technologies. Again, rather than resorting to a “super” fibre backbone operator, regulators can promote synergies among different kinds of utilities or projects that employ internal communication links. Energy and transport infrastructure projects, for instance, could be encouraged to deploy fibre too. Telecommunication operators could then access these facilities to augment their networks.

#### 5.2 Topologies for optical user access

Optical fiber can be used in point-to-point mode or in the form of a passive optical network (PON), in which case its capacity is shared among a number of homes. The terminology currently used is as follows:

- FTTB (fiber to the building): The fiber is taken as far as the building, at which point technologies such as DSL, WiMAX, WiFi, Ethernet and so on take over.
- FTTC (fiber to the curb): The fiber is laid as far as a distribution frame serving a group of buildings, and from there the aforementioned technologies are used to complete the user links.
- FTTH (fiber to the home): The fiber is taken as far as the user’s home and supports very high bit rates.
- FTTO (fiber to the office): The fiber arrives at the office, from where links are generally based on Ethernet or WiFi technologies.
- FTTN (fiber to the neighborhood): The fiber reaches as far as the neighborhood and from there links with individual users are based on DSL, WiMAX, WiFi, Ethernet and so on. This topology is also called “fiber to the node”.
- And FTTV (fiber to the village) is specifically related to rural and remote areas, in which topology the fiber is deployed as far as a node in/nearby the village and from there links are generally based on DSL or WiMAX technologies.



Figure 2: Topologies for optical user access

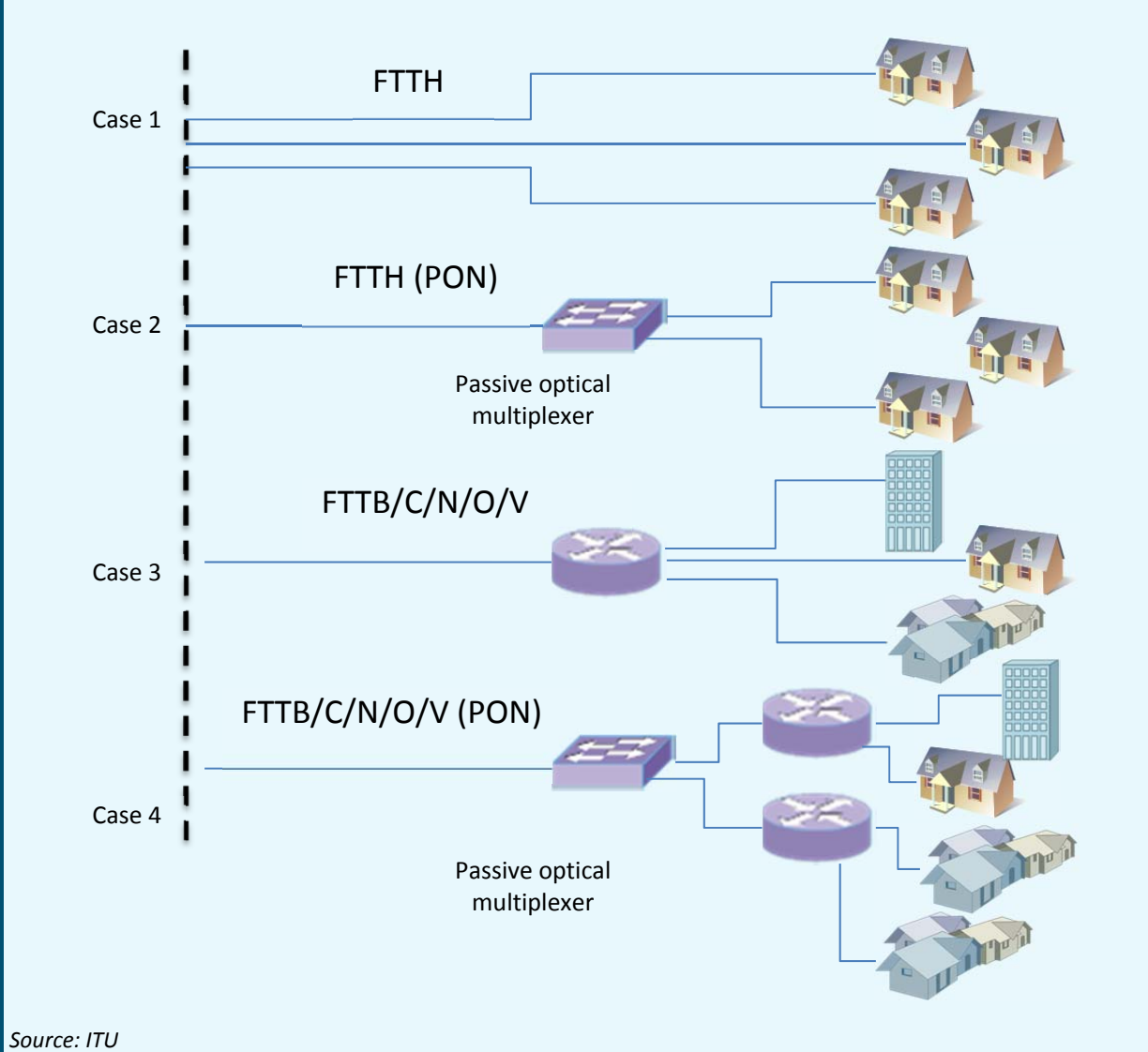

**Case 1:** A point-to-point fiber links the user's equipment to the network. The transmission technology used is 100 Mbit/s or 1 Gbit/s Ethernet. This technology is standardized. A bit rate of 10 Gbit/s is possible for intranet interconnectivity, host access, cloud computing or applications requiring very high bit rates.

**Case 2:** A passive optical network—EPON (Ethernet PON), GPON (Gigabit-capable PON), GEAPON (Gigabit EPON), 10G-PON (10 Gigabit PON), 10G-EPON, G.epon or WDM PON (wavelength-division multiplexing PON)—serves a number of users from a single optical network connection point. This solution, which provides only a portion of the available bit rate for each user, can have advantages in terms of its lower cost, since a single network access point and a single optical fiber nearby to the access point can be used to serve several dozen users. Passive 100 Mbit/s optical networks are confined to traditional applications such as data transmission, telephony and telemetry. High-speed passive networks and WDM PON make it possible to offer triple-play services, video on demand and other services requiring high transmission capacity.

**Case 3, case 4:** This shows the connection of a group of users for whom the optical fiber is taken as far as the neighborhood (FTTC or FTTN), the building (FTTB) or the village (FTTV). This type of backhauling is used by most telecommunication and cable operators. The final part of the connection uses VDSL, CATV or possibly WiFi technology.

With the decline of fiber cost, the optical user access may be considered for deployment in rural and remote areas, especially in the following pre-conditions:

- The user base is relatively concentrated and the broadband demand is relatively high (the relative concentration refers to that the cable length between the two nearest broadband users should not be more than 1KM).
- The cable theft is severe, and the stolen cables are not less than 100 pairs or after the stolen cable is cutovered, the length of removable cable is 1.5KM and above.
- To enhance the quality of network: the cable length above 2KM, broadband demand existing, cables aging and serious failure frequently happening, many customer complaints, and high maintenance costs.
- Revitalize the copper resources: provided the value of removable cable is more than the investment of fiber access, it is possible to substitute the fiber for copper line, where it is generally required that the removable cable is more than 200 pairs with the length over 2KM in the same direction.

China is using optical broadband to facilitate the deployment of rural information infrastructure with the objective to realize fiber to the township and promote the basic Internet access bandwidth in rural home to be over 4Mbps in 2015. In addition, telecom operators in China are utilizing FTTH technology to expand network coverage and improve the quality of rural broadband access to meet the farmers' demand for broadband services in the relatively affluent rural areas of eastern China.

### 5.3 Technical characteristics of P2P optical access and PON

#### 5.3.1 Point-to-point optical access (EFM: Ethernet in the First Mile)

Point-to-point user access is more expensive (around 10 per cent) than point-to-multipoint because one optical fiber and one network connection are required for each user. On the other hand, this topology allows very high transmission speeds. Point-to-point access generally makes use of Ethernet layer 2 technology. Range is independent of bit rate because fiber displays the same attenuation for different transmission speeds.

This technology is also known as EFM (Ethernet in the first mile) in the standard IEEE 802.3ah. Its physical layer with optical fiber is specified in the following documents:

- 100BASE-LX10: 100 Mbit/s over a pair of single-mode optical fibers using a wavelength of 1 310 nm; range up to 10 km.
- 100BASE-BX10: 100 Mbit/s over an individual single-mode optical fiber using wavelengths of 1 310 and 1 550 nm for the upstream and downstream directions; range up to 10 km.
- 1000BASE-LX10: 1 Gbit/s over a pair of single-mode optical fibers using a wavelength of 1 310 nm; range up to 10KM.
- 1000BASE-BX10: 1 Gbit/s over an individual single-mode optical fiber using wavelengths of 1 310 and 1 550 nm for the upstream and downstream directions; range up to 10 km.
- 10GBASE-LR: 10 Gbit/s over a pair of single-mode optical fibers using a wavelength of 1 310 nm, range up to 10km.
- 10GBASE-LW: 10 Gbit/s over a pair of single-mode optical fibers using wavelength of 1 310 nm; range up to 10km; for connections to SDH/SONET equipment.

To meet demands for even higher speed, there is provision for interfaces using a number of different wavelengths:

- 40GBASE-LR4: 40 Gbit/s over a pair of single-mode optical fibers using wavelengths of 1 270, 1 290, 1 310 and 1 330 nm, each carrying 10 Gbit/s; range up to 10 km.
- 100GBASE-LR4: 100 Gbit/s over a pair of single-mode optical fibers using wavelengths of 1 295, 1 300, 1 305 and 1 310 nm, each carrying 25 Gbit/s; range up to 10 km.

### **5.3.2 EPON/GEPON/10G-EPON (Ethernet Passive Optical Network / Gigabit Ethernet PON/ 10 Gigabit Ethernet PON)**

The IEEE 802.3ah standard also defines, in addition to point-to-point optical access, user access in the form of a passive optical network. Time-division multiplexing technology makes it possible to allocate the optical channel capacity of 1 Gbit/s to 8, 16, 32, 64 or 128 users connected to the PON. It uses the native Ethernet protocol according to a transmission mode that lies between shared medium with collision detection and point-to-point Ethernet.

In the downstream direction, Ethernet broadcast mode allows information to be transmitted to each user without any particular additional measure. The MAC address of the reception equipment makes it possible to extract the right stream for each user. In the other direction, the problem is more complex.

A number of user systems can have simultaneous access to the physical medium and transmit information. A specific protocol has been developed under the IEEE 802.3ah standard. This protocol – MPCP (multipoint control protocol) – facilitates efficient allocation of transmission channel capacity. The physical media specified for EPON/GEPON are as follows:

- 1000BASEOPX10: 1 Gbit/s, point-to-multipoint access on an individual single-mode optical fiber using wavelengths of 1 310 and 1 490 nm for the upstream and downstream directions of transmission; range up to 10 km.
- 1000BASE-PX20: 1 Gbit/s, point-to-multipoint access on an individual single-mode optical fiber using wavelengths of ~1 270 and ~1 590 nm for the upstream and downstream directions of transmission; range up to 10 km (PR10) or 20 km (PR20).

The IEEE 802.3av standard published in 2008 specifies a 10 Gbit/s passive optical network. Two variants are proposed, with optical multiplexing of 1:16 or 1:32. The first is symmetrical and provides 10 Gbit/s in both directions. The second supports 10 Gbit/s in the downstream direction and 1.25 Gbit/s in the upstream direction. The specified physical media are as follows:

- 10GBASE-PR: 10 Gbit/s symmetrical over an individual single-mode optical fiber using wavelengths of ~1 270 and ~1 590 nm for the upstream and downstream directions of transmission; range up to 10 km (PR10) or 20 km (PR20).
- 10/1GBASE-PRX: 10 Gbit/s downstream and 1.25Gbit/s upstream over an individual single-mode optical fiber using wavelengths of ~1 270 and ~1 590 nm for the upstream and downstream directions of transmission; range up to 10 km (PRX10) or 20 km (PRX20).

### **5.3.3 GPON/10G-PON (Gigabit-capable PON OR Gigabit PON/10 Gigabit PON)**

GPON was defined by ITU following on from the two types of passive optical network based on ATM, APON (ATM PON) and BPON (Broadband PON) technology. Recommendation ITU-T G.984 which specifies GPON, allows for different data rates, but the industry has chosen 2.5 Gbit/s for downstream and 1.25 Gbit/s upstream. GPON performs more efficiently than its predecessors thanks in particular to variable-size frames and a very efficient encapsulation mechanism. 10G-PON offers downstream speeds of 10 Gbit/s and upstream speeds of 1.25, 2.5 or 10 Gbit/s. The actual values are those of the synchronous digital hierarchy, namely 1.244 Gbit/s, 2.488 Gbit/s and 9.953 Gbit/s. The wavelengths chosen for 10G-PON enable it to coexist with GPON on the same passive optical network, making it possible to upgrade the system user by user.

- G.984: 1 Gbit/s, point-to-multipoint access on an individual single-mode optical fiber using wavelengths of 1 310 and 1 490 nm for the upstream and downstream directions of transmission; range up to 20km.
- G.987: 10 Gbit/s, point-to-multipoint access on an individual single-mode optical fiber using wavelengths of 1 270 and 1 577 nm for the upstream and downstream directions of transmission; range up to 20 km.

### 5.3.4 G.epon/SIEPON

G.epon is expected to be defined by ITU-T and be standardized in July 2013, which is the ITU-T version of SIEPON (Service Interoperability in EPON) Package B standard defined by IEEE P1904.1 WG in order to improve EPON (including GE-PON and 10G-EPON) interoperability. These standards define system level specifications such as EPON architecture model, Quality of service, ONU power management, protection switching, and OAM (Operation, Administration, and Management) function. Additionally, G.epon can support Generalized OMCI management defined by ITU-T G.988 in common with other ITU-T PONs such as B-PON/G-PON/XG-PON.

### 5.3.5 WDM PON (Wavelength- Division Multiplexing PON)

The wavelength-division multiplexing passive optical network allows very high transmission speeds between each user and the network terminal. This is more expensive than classic PON but allows for very high speeds by making an individual optical channel available to each user, for example each enterprise in a business complex or each apartment in a residential building. WDM PON technology is promoted by certain equipment suppliers but has not yet been standardized.

**Table 3: Advantages and drawbacks of P2P optical access and PON**

	Advantages	Drawbacks
Point-to-point	<ul style="list-style-type: none"> <li>Very high-speed individual link</li> <li>Long range (<math>\geq 10</math> km)</li> <li>Compatible with current and future services</li> <li>Secure transmission with no need for data encryption</li> <li>Smooth evolution for FTTH since the fiber is transparent between the user and the network equipment</li> </ul>	<ul style="list-style-type: none"> <li>Highest cost because the fiber generally has to be laid (civil engineering work)</li> <li>Slower roll-out because of the need to lay one fiber per user.</li> </ul>
PON	<ul style="list-style-type: none"> <li>Minimizes fiber deployment and the number of network ports</li> <li>Reduces costs by sharing transmission capacity among users</li> <li>Multicast services can be offered</li> <li>No active element between user and exchange; reduced maintenance</li> <li>Smooth evolution for FTTH since the fiber is transparent between the user and the network equipment</li> <li>Faster roll-out than with point-to-point</li> </ul>	<ul style="list-style-type: none"> <li>Data must be encrypted because the medium is shared</li> <li>Capacity shared among users</li> <li>Unbundling more difficult than with point-to-point</li> </ul>

### 5.3.6 Outlook of optical user access technologies

Optical access (FTTx – fiber to the building, curb, home, etc.) is one of the fastest-growing markets. Optical fiber is the only wired medium capable of providing the sort of data speeds required by triple play services to a distance of 10 km or more. It will become established in the form of a CATV or VDSL backhaul system, a point-to-point link to users, or a passive optical network. EPON/GE-PONs, the first systems on the market, have been deployed mainly in the Asian market, while GPON has been widely adopted in the United States.

## 5.4 Topologies for optical backhaul

Optical fiber will in most cases remain the idea medium for backhauling between the periphery and the network core. Owing to the marked growth in volumes of data exchanges between users, backhaul has to cope with an ever-growing demand for higher data speeds for things such as triple play, video on demand, HDTV, IPTV, videoconferencing, interactive video and video games, cloud computing and data transfer.

Three backhaul topologies are compared in the Figure below: SDH (synchronous digital hierarchy) ring; point-to-point link of Ethernet ring; and optical ring with reconfigurable optical add-drop multiplexers (ROADM).

**Table 4: Advantages and drawbacks of optical technology in backhaul**

	Advantages	Drawbacks
<b>SDH</b>	Flexible and robust technology Control elements incorporated in frame headers Visibility of tributaries Ensures continuity of network synchronism	Transport of only one network synchronism(multi-operator systems) Higher costs than Ethernet technology
<b>Carrier Ethernet</b>	Lower cost for given bit rate Compatible with IP/Ethernet technology used at network extremities	Requires additional mechanism to ensure continuity of synchronism Lack of confidence in quality of service and performance
<b>Ethernet on ROADM</b>	Add/drop at the optical level Ease of planning and provision of optical channels Flexibility in remote reconfiguration of optical equipment ( for each wavelength at any location) Anticipated fall in maintenance costs	Technology not yet standardized

#### 5.4.1 Synchronous Digital Hierarchy (SDH) backhaul

The synchronous digital hierarchy (SDH) was developed by ITU in the late 1980s on the basis of a development by the Bell Corporation known as SONET (Synchronous Optical NET work). The bit rates available are: 155.52 Mbit/s, 622.08 Mbit/s, 2.488 Gbit/s, 9.953 Gbit/s and 39.813 Gbit/s.

The specified multiplexing structure allows a range of plesiochronous digital hierarchy (PDH) streams to be carried at speeds E1/T1 (2.048/1.544 Mbit/s), E3/T3 (44.736/34.368 Mbit/s), and E4 (139.264 Mbit/s) inside suitable “containers” in the synchronous hierarchy. These plesiochronous streams can easily be added and dropped in the SDH transmission at each SDH cross-connect node. The fundamental SDH Recommendations were published in the spring of 1991, as follows:

- G.707: General characteristics of the synchronous digital hierarchy
- G.708: network node interface for the synchronous digital hierarchy
- G.709: structure of synchronous multiplexing

SDH has the advantage of ensuring continuity of synchronism in the network without any particular action being required, unlike other technologies derived from the Internet, for which specific measure are required.

SDH can be implemented in a range of different topologies. The simplest is point-to-point, with a multiplexer-demultiplexer at each end. It is possible to create a bus by incorporating multiplexers to add and drop tributaries. The most common topology is a ring with tributary add/drop multiplexers. SDH technology also makes it possible to use mesh topologies with the aid of digital cross connects which allow tributary add/drop without any restriction of bit rate.

SDH transmission systems use wavelengths of 1 310 or 1 550 nm, on single-mode fiber. The distances covered are 15 km (G.652 fiber), 40 km (G.652 fiber, 1 310 nm) and 60 km (G.652, G.653 or G.654 fiber, 1 550 nm).

SDH can be operated with transmission systems using optical wavelength-division multiplexing, thus multiplying the capacity of the backhaul links.

### 5.4.2 Ethernet backhaul (Carrier ethernet)

Demand for backhaul capacity is set to increase far more quickly than the revenues that operators may obtain from it. A growing proportion of that demand will be associated with best-effort traffic, which will encourage the players involved to seek more advantageous, flexible and efficient solutions. Owing to the evolution of backhaul traffic, the introduction of all-IP-based NGNs and the costs of acquiring and managing synchronous systems, backhaul will shift towards Ethernet technology.

Transition to a transport concept based entirely on Ethernet technology (carrier Ethernet) confronts operators with the problem of ensuring continuity of network synchronism, something required (for example) by current cellular systems and fourth-generation systems. The transport network may be operated by a wholesale operator offering transport capacity to a number of mobile network operators. This requires continuity of synchronism for multiple operators. A range of solutions exist to synchronize packet networks, such as ITU's SyncEthernet, IEEE's precision time protocol (PTP), or GPS synchronization.

Standards authorities and manufacturers have made serious efforts to overcome the limitations of Ethernet in operators' networks. This has resulted in a series of new standards on, inter alia, interface speeds, management aspects, and scalability of Ethernet:

- IEEE 802.1 ad-provider bridges: allows integration of a user's own VLAN into an operator's VLAN; multiple VLAN tags in a single Ethernet frame.
- IEEE 802.1 ah-provider backbone bridges: complements IEEE 802.1 ad
- IEEE 802.1 ag-connectivity fault management
- IEEE 802.1 Qay-provider backbone bridge – Traffic engineering: Aims to make the Ethernet protocol scalable, deterministic and more reliable.
- Y.1731: OAM functions and mechanisms for Ethernet-based networks

In addition, high-speed Ethernet interfaces are proposed or in the process of standardization:

- 10GBASE-E: 10 Gbit/s over a pair of single-mode optical fibers using a wavelength of 1 5550 nm; range up to 40 km.
- 100GBASE-ER4: 100 Gbit/s over a pair of single-mode optical fibers using wavelengths of 1 295 1 300, 1 305 and 1 310 nm, each carrying 25 Gbit/s up to 40 km.

### 5.4.3 Ethernet backhaul with add /Drop optical wavelengths

The evolution of optical transport networks towards very high data speeds relies on optical wavelength division multiplexing and equipment that allows add/drop of optical streams at any node in a ring or meshed network from a remote control center.

The concept of optical transport network (OTN) is defined by ITU in a series of Recommendations, including:

- G.872: Defines OTN architecture. The aim is to establish a standardized framework for the deployment of multi-service networks.
- G.709: Describes the network node interfaces, data rates and their correspondence with SDH and Ethernet bit rates up to 100 Gbit/s.

The concept of reconfigurable optical add/drop multiplexer (ROADM) is in the same line of development. The stated aim of equipment suppliers is to reduce configuration costs and offer greater flexibility in management of optical network. Channel switching (optical wavelengths) in the add/drop nodes is done at the optical level, according to users' needs. There is no signal conversion between optical and electronic elements. This technology, which is now on the market, has not yet been standardized.

### 5.4.4 Outlook of optical backhaul technologies

Most global operators already use Ethernet technology for backhaul and many are planning to go all-Ethernet. Before doing so, however, they want proof that performance and quality of service can be guaranteed. This is something that Ethernet technology alone is unable to offer, because it was developed

for best-effort service. There is no shortage of arguments in favor of going over to Ethernet: for example, the fact that the traffic is on IP/Ethernet at the network extremities or the falling costs of Ethernet owing to its inexorable deployment on a very large scale. According to the carrier Ethernet concept, Ethernet can be deployed in a conventional manner (pure Ethernet) with an SDH transmission system or MPLS (multiprotocol label switching).

## 5.5 Terrestrial wireless technologies

Wireless solutions are ready to be deployed where connectivity by wired technologies is:

- too expensive/difficult to install
- too slow to deploy
- not well adapted to the degree of nomadic/mobility usage requirements

Typical wireless solutions can be broken down into two basic categories:

- 1) Point-to-point (PTP): a dedicated bandwidth and channel solution using dedicated spectrum resources between two locations, these solutions are suitable for hops from 1km to many 10's of km. e.g. microwave links. Such solutions typically require Line of Sight (LOS) between end points to operate.
- 2) Point-to-multi-point: a shared bandwidth radio channel with a common centralized base station/concentrator used to connect n x endpoints; these solutions are suitable for short hops of typically a few km only, e.g. WiFi or Mobile networks. Such solutions typically operate without Line of Sight, i.e. Non LOS (NLOS) at short range. Such solutions depend on a Backhaul solution back to a point of presence and this can be either provided by 1 above, or by a satellite link.

Mobile Network Operators (MNO) typically deploy high-powered "macro" cells covering large areas (large compared to current WiFi cells, for instance). Such solutions using the new IMT mobile technologies in the 700 MHz / 800MHz bands offer the potential for large cells (10km plus) in rural areas with large throughputs. Likewise, low-cost wireless solutions leveraging proprietary and standards-based technologies, such as Wi-Fi, in unused "white spaces" frequencies below 1 GHz are being introduced, which can deliver high-capacity multi-kilometer (10km plus) broadband connections.

An alternative use of current MNO spectrum holdings, available today, is the deployment of "Small Cell" or "Metro Cell" technology. Metro Cells are small, low-powered, base stations that can be deployed outdoors in rural areas as well as indoor residential or commercial properties. They offer the advantages of being smaller, lighter, energy efficient, with lower installation and operational costs. Metro cells can be deployed in a similar way to WiFi access points while offering mobility and voice coverage as well as a data solution. Small cells are successfully deployed by wireless operators in developed markets as a means of plugging gaps in network coverage or expanding coverage at the edge of the network where the signal does not penetrate indoors. For example, 'femtocells' have proved a successful means of providing services in hard to reach rural and remote areas in countries such as the UK. Following these successes, wireless operators are now using the same technology in developing countries to enable greater access to mobile broadband applications.

### 5.5.1 Spectrum and bandwidth requirements

Wireless solutions require spectrum to operate. There are two basic types of spectrum:

- 1) Licensed spectrum, which is assigned to operators either directly by the regulator, or through secondary trading from a primary licensee, and therefore can expect a degree of interference protection.
- 2) Unlicensed spectrum, where, pending compliance with minimal technical requirements, an operator (or more generally the user of the spectrum) uses spectrum that is available to all without registration or any form of interference protection. In some countries (e.g. UK) there is a subset of unlicensed spectrum called "lightly licensed" which requires a registration into a regulator database and small annual fee but does not afford any formal protection against interference. New

technologies to access spectrum on a license-exempt or unlicensed basis through regulated frequency databases are becoming available, and regulatory frameworks to support these technologies in the unused VHF and UHF TV band frequencies (the “TV White Spaces”) have been developed (for example, in the United States of America) or are currently under development (for example, in Canada, Singapore, and the United Kingdom) with the aim of ensuring operation without interference to incumbent licensees.

Spectrum has different propagation characteristics and channel bandwidths, and can suffer congestion and interference issues. Some spectrum propagates well (long wavelength spectrum) but typically has low channel bandwidths and operates under NLOS conditions, while other spectrum propagates less well (short wavelengths) but has high channel bandwidths.

Wireless capacity depends mainly on the channel bandwidth. Very high frequency links can exploit wide channels up to and including 1Gbps, though most links deployed today are in the 2–155Mbps range for practical and propagation reasons.

### **5.5.2 Range of possible solutions**

Selection of the optimum broadband wireless solution is therefore based on the following basic criteria:

- Distance of the required connection
- Bandwidth of the required connection
- Fixed/Nomadic or Mobile solution required
- Licensed or unlicensed spectrum access

Table 5 below provides indications of possible solutions against the above criteria for point to point (PTP) microwave links and Point to Multi-Point (PMP) solutions.



**Table 5: Possible solutions for point to point (PTP) microwave links and Point to Multi-Point (PMP) solutions**

Criteria/ Solution	PTP micro- wave (7–38GHz)	PTP microwave (80GHz)	PTP 5.8GHz	PMP 2.4GHz/5G Hz (Wi-Fi)	PMP 3.5/10GHz	PMP IMT– 2000 mobile networks	PMP IMT– Advanced mobile networks
<b>Hop distance</b>	1km–30km LOS	0–3km LOS	0–7km LOS 0–1km NLOS	0.02km LOS 0.01km NLOS	Up to 5km LOS 1 km NLOS	Up to 5km LOS 1km NLOS	10km+ LOS
<b>Bandwidth (throughput)</b>	up to 600Mbps, typically 155Mbps	1Gbps	30Mbps typical	30Mbps typical shared	34Mbps typical shared	14Mbps typical shared	30Mbps typical shared
<b>Fixed/Nomadic/ Mobile</b>	F	F	F	F/N	F/N	F/N/M	F/N/M
<b>Unlicensed/ Licensed spectrum</b>	L	Depending on countries (lightly licensed in UK & US)	U (lightly licensed) Interference	U (5.8GHz lightly licensed)	L	L	L
<b>Notes</b>	Solution good for high availability bandwidth, though with Opex fees (£500 per link fee to OFCOM)	Low Opex, high bandwidth solution for short hops (£1 per year per link to OFCOM)	Solution good for low Opex, though typically poor availability (directional multi Antennas) Cheap but noise risk	Metro Cell technology can provide a similar solution with MNO cooperation	Fixed wireless solutions. License cooperation required to deploy	IMT–2000 technologies in the IMT– 2000 bands	IMT– Advanced technologies in the 700/800 MHz bands

Note: Some of the above technologies could be enhanced through the use of capacity transfer repeaters

### 5.5.3 Access deployment

From the above table it can be seen that multiple wireless solutions can be deployed to meet varying bandwidth requirements, expected availabilities, spectrum license regimes, and fee schedules. The mobile network is a key delivery platform for broadband to users on the move, as well as to communities in rural and remote areas.

In particular, it should be noted that, with the advent of new wireless technologies such as LTE, peak data rates and spectral efficiencies (bits per Hertz) are improving substantially. However guaranteeing peak data rates of 1.5Mbps per user, it remains to be seen whether the number of premises served by any given base station is the same as in today's mobile networks which were initially designed for voice services. In wireless networks, peak data rates decrease with increasing distance of the transmitter. If 1.5Mbps peak data rates are to be achieved for all customers using a particular wireless network, the network must be dimensioned so that the premises on the outer edge of the cell boundary can receive the 1.5Mbps peak data rate. This has the consequence that users closer to the cell site can experience peak data rates much higher than 1.5Mbps, up to 100Mbps. However telecommunication networks are dimensioned with less capacity than the sum of all access connections would require if they were all used concurrently at their maximum potential, with the resulting restriction of performance known as 'contention'. The contention is particularly acute with shared access media such as wireless. A cell site with 30Mbps capacity in a sector could simultaneously provide an average data rate of 1.5Mbps to 20 premises.

#### **5.5.4 Middle range transmission media**

MEO (“medium Earth orbit”) satellite systems are ideally suited to providing “middle mile” trunking and backhaul capacity for national telecom operators, mobile operators, ISPs, large enterprises and government agencies. Because a MEO satellite system is much closer to the Earth than a geostationary satellite, there is a far lower latency in the signals, which is essential for many types of today’s IP-based and broadband services.

With low latency combined with wide bandwidth and high throughput, a MEO satellite system can be the much-needed middle mile in remote and rural areas where traditional terrestrial and geostationary satellite technologies have not or cannot provide the necessary broadband capacity. O3b Networks, for example, can provide high throughput (1.2 Gbits per transponder), wide bandwidth (up to 216 MHz per transponder), all with very low latency (under 150 msec roundtrip). MEO satellites are smaller than geostationary satellites, and therefore less expensive to build and launch. These savings result in much more affordable satellite broadband capacity, while also bringing data speeds that are comparable to fiber.

MEO satellite systems with steerable beams, offer maximum flexibility for capacity customers to deploy high speed IP trunks wherever needed. For example, O3b satellites are designed with dynamic, steerable beams which are capable of deploying very high speed broadband capacity easily into the rural and remote parts of a country – exactly where required by domestic telcos, mobile operators, ISPs, and government agencies (such as to support of national ICT plans). Furthermore, in order to address increased and re-defined customer demand, a MEO satellite system can re-direct beams, dedicate more beams to a region, and/or launch additional satellites into the same ITU-filed orbital plane and altitude.

#### **5.5.5 Backhauling**

The growth in number of subscribers and the introduction of increasingly popular applications will impact the mobile backhaul network very fundamentally. The mobile backhaul network will be one of the key elements in delivering broadband solutions to the end user. In addition to the PTP technologies listed in table 1 above, the following solutions could be considered:

- Dedicated bandwidth provision to a premise with point-to-point/point-to-multi-point links operating in the 5GHz lightly-licensed band offering around 30Mbps throughput.
- Community Meshed Wireless access: multiple wireless access points can be meshed to each other to extend the reach and resilience of a community of Access Points (AP) using proprietary meshing algorithms operating on standard WiFi AP equipment.
- LTE-A includes self-backhauling capabilities with relays. Relays constitute efficient and easy methods to extend coverage, and enhance cell edge performance without requiring backhaul or installation of large masts. More conventional eNB can be installed later as the traffic volume increase.
- Capacity transfer repeaters can be a key element of mobile cellular network infrastructure. The use of repeaters is technology- and standard- independent. The deployment of this technology makes it possible to reduce capital and operating costs by two or three times and to reduce electricity consumption by 2.5 to 4 times.

### **5.6 Technologies for connecting remote areas and rural communities**

Depending on local conditions such as geographic location, economic prosperity, rural or urban environments and local terrain, there is a role for a host of different technological solutions in providing broadband access – from cable to fixed wireless; from satellite to microwave; from xDSL to mobile technologies; and many more.

### 5.6.1 Overview of satellite-based solutions

Broadband access is an important indicator for economic development. In some countries, broadband can be provided to densely populated major cities and urban areas by laying a national fibre backbone infrastructure. Although fibre backbone infrastructure might be preferred for urban areas with high population technologies, satellite technology can play an important role in serving remote areas, rural areas or sparsely populated areas, where the expansion of terrestrial fibre is unlikely. Increasingly, governments have developed goals and strategies to ensure access to all citizens, but have been challenged to meet objectives in rural and remote areas. Many countries' broadband goals may not be achieved without a mix of broadband technologies, including cable, fiber, wireless – and satellite. Different technologies offer different advantages, but it is clear that satellite communications offer major potential for deploying 'universal' broadband services rapidly to large numbers of people. Satellite broadband can prove an ideal solution in remote areas, rural areas or large, sparsely populated areas, while satellite technology can also provide full coverage in rural, as well as metropolitan, areas. Terrestrial infrastructure is often concentrated in urban centers, with limited coverage for rural and remote areas, preventing segments of the population from benefiting from the information society.

Satellites also provide invaluable solutions, particularly for providing capacity in hard-to-reach rural areas and for providing the essential backhaul capacity needed by other operators to reach their customers.

Ongoing advancements in satellite networks, ground equipment and applications have made satellite technologies an increasingly cost-effective solution – and a critical component of telecommunications and broadband access strategies and national broadband plans, particularly to ensure coverage in remote and rural areas. Satellite-based Internet and broadband services, in addition to backhaul solutions, provide an opportunity to extend connectivity to even the most remote areas where terrestrial-based (wired or wireless) services are unavailable or expensive to deploy. With increased demand and the development of rural or universal access broadband strategies, there has been an increase in demand for satellite-based solutions for rural and remote areas, including through government-led projects or public-private partnerships which aim to increase access. This section provides an overview of some of the available and emerging satellite-based solutions – many of which are currently deployed in developing country markets.

#### 5.6.1.1 Fixed Satellite Service (FSS) applications

##### Satellite Internet and Broadband Access Technologies and Solutions

Satellite services are increasingly being implemented as an internet and broadband access solution in both developed and developing country markets. Satellite-based services offer many advantages, particularly for remote and rural areas where terrestrial infrastructure is limited, such as:

- ubiquitous coverage to all corners of the globe;
- cost-effective and easy-to-install solutions, even for remote and rural areas;
- no significant ground infrastructure investment required;
- sustains large end-user populations;
- capable of large network deployments;
- fixed and mobile applications; and
- reliable and redundant services in the case of a disaster or emergency situation.

##### Ready to deploy-Globally

Given their unique regional and global coverage capabilities, satellites are able to deliver immediate internet and broadband connectivity even to remote areas using existing satellite resources. This gives the flexibility and capacity to extend the service footprint based on market demand, instantly and easily covering rural areas. Importantly, particularly for developing regions, end-user and community connectivity is possible without huge capital investments or extensive build-out programs. Once a satellite system is operational, connectivity can be further extended to user locations with easy-to-deploy and install ground terminals. As users increase, economies of scale enable cheaper equipment,

making satellite an even more competitive solution since build out is not sensitive to distance or location as with fiber.

Moreover, high-density, small-dish services, which can be enabled by higher PFD levels, offer the opportunity for even more cost-effective connectivity. As next generation satellite networks are launched, capacity is increasing and higher speed, lower latency options make satellite even more attractive as a solution.

### Medium earth Orbit Non-Geostationary satellites for rural/remote ICT connectivity

Satellite systems that use non-geostationary satellite orbits (NGSO) usually have a lower orbital altitude than geostationary satellites (GSO), which operate at approximately 36,000 km altitude. One type of NGSO satellite system uses a Medium-Earth Orbit (“MEO”), which follows circular orbits around the Equator. Other NGSO satellite system operate in low-Earth orbits (LEOs), sometimes in circular but inclined orbits that provide better coverage to higher latitudes, such as the Scandinavian countries. While still other MEO systems employ elliptical orbits that are closer to the earth at one point in their orbit and farther at the opposite point.

#### Example of an NGSO satellite system: O3b

O3b is an example of an NGSO satellite system using a medium-earth orbit (MEO), operating in the Ka-band Fixed Satellite Service (FSS). O3b selected a circular, equatorial orbit altitude of 8,062 kilometers, resulting in a 288 minute orbit timeframe, to primarily balance round-trip transmission latency; satellite and launch costs; and ease of operations. The O3b MEO orbit altitude is approximately 4 times closer to the Earth allowing smaller, lower cost satellites to be used while generating the same equivalent GSO EIRP. Each O3b satellite will orbit the Earth five times a day and, taking into account the Earth’s rotation, will therefore pass overhead at the same ground location four times a day. This MEO orbit allows each satellite to flexibly provide service to multiple regions globally versus a single region as a GSO. The combination of these features results in the use of MEO satellites being substantially more affordable than using GSO satellites.

O3b’s particular MEO satellite network design will provide continuous coverage up to 45 degrees north and south of the Equator, providing around 70% of the world’s population with fiber quality internet connectivity. Launching its initial 8 satellites in 2013, O3b will have 7 service regions (see figure below, with regional gateways indicated). Four additional satellites are already well under construction, which when launched, will increase the global service area even further. Gateway and local customer earth stations operating with MEO satellites will track each satellite across the sky to maintain seamless and high-availability communications.



O3b MEO satellite design provides several major advantages:

- **High Availability:** Fiber is not always available, especially for landlocked nations, and rural and remote areas of a country. In addition, GSO coverage may not be complete over certain countries or regions (such as the Pacific Ocean island nations). O3b can extend the reach of these other technologies and deploy its fiber-equivalent capacity to any corner of a nation at any time desired by a government or telecom operators in a country. O3b can also add capacity dynamically with additional beams as localized capacity demands grow.
- **Affordable Cost:** O3b's MEO design will create substantial savings compared to either GSO capacity, or to building and maintaining thousands of kilometers of fiber infrastructure or hundreds of radio towers to interconnect cities and towns. Rural areas with several small to medium size towns will be able to obtain low latency, high rate internet connectivity with very little capital expenditures ahead of initiating service.
- **High Throughput:** Throughput is measured in the steady state flow of megabits per second (Mbps) and is important for downloading large files, watching video, or other bandwidth intensive utilization. O3b provides scalable bandwidth from 100 Mbps up to 1.2 Gbps per beam in clear sky. Each 700 km wide beam on the ground can be steered to any location ahead of fiber, moved as demographics change, or moved as the market demands, providing added flexibility in rolling out broadband and mobile voice services nationwide. O3b's high powered satellites will also allow it to provide high throughput to small terminals mounted directly onto cellular towers.
- **Low Latency:** Latency is the round trip time that each packet takes between a computer and the server. Latency dictates how fast web pages load and how well collaborative online applications function. Compared to GSO satellites with approximately 500–600ms latency, the MEO altitude utilized by O3b enables round trip customer-gateway latencies of <150ms, very close to that experienced in a pure terrestrial fiber-based network, and critical to the provision of the real-time, interactive applications. Furthermore, because cellular backhaul today is made up primarily of voice traffic, O3b's MEO system low latency enables high quality voice and is a very good solution for backhaul. If digital infrastructure is to be a true economic engine in the future, network operators must consider low latency, in addition to high throughput, as a key driver in successful broadband network implementation.
- **Strong Public Benefits:** As telecom and mobile operators consider how to build out their networks to reach their service obligations in the rural and remote parts of their countries, governments are also evaluating their role in accelerating deployment of broadband technology to their most needy populations. O3b's beam flexibility provides governments with an important tool in the fulfillment of their national broadband plans on the ambitious schedules many have announced. In addition, O3b's MEO satellite capacity can serve as an easily deployable high-speed communications backbone for disaster recovery efforts, and can provide critical redundancy to long haul fiber cables (either within a country or for submarine cables serving a country).

A connected world enables new levels of understanding, sharing of ideas and has a pronounced impact on economic growth, knowledge development, and efficient government. This connected world however requires modern and resilient communications infrastructure.

O3b Networks is committed to addressing the needs of the "Other 3 Billion" people in the world who do not have access to high-speed Internet services. In 2013, O3b Networks will launch its state-of-the-art MEO satellite system to bridge the digital gap.

O3b Networks is partnering with telecom operators, ISPs, mobile operators, large enterprises, and government agencies around the world to bring affordable, fiber-speed satellite broadband connectivity to precisely those that need it the most.

**MEO satellite design provides several major advantages:**

- **High Availability:** Fiber is not always available, especially for landlocked nations, and rural and remote areas of a country. In addition, GSO coverage may not be complete over certain countries or regions (such as the Pacific Ocean island nations).

- **Affordable Cost:** MEO design can create substantial savings compared to either GSO capacity or to building and maintaining thousands of kilometers of fiber infrastructure or hundreds of radio towers to interconnect cities and towns. Rural areas with several small to medium size towns will be able to obtain low latency, high rate internet connectivity with very little capital expenditures ahead of initiating service.
- **High Throughput:** Throughput is measured in the steady state flow of megabits per second (Mbps) and is important for downloading large files, watching video, or other bandwidth intensive utilization. Proposed NGSO systems provide scalable bandwidth and spot beams which can be steered to any location ahead of fiber, moved as demographics change, or moved as the market demands, providing added flexibility in rolling out broadband and mobile voice services nationwide.
- **Low Latency:** Latency is the round trip time that each packet takes between a computer and the server. Latency dictates how fast web pages load and how well collaborative online applications function. Compared to GSO satellites with approximately 500–600ms latency, the MEO altitude of e.g. 8000km enables round trip customer–gateway latencies of <150ms, very close to that experienced in a pure terrestrial fiber–based network, and critical to the provision of the real–time, interactive applications. Furthermore, because cellular backhaul today is made up primarily of voice traffic, such a MEO system low latency enables high quality voice and is a very good solution for backhaul. If digital infrastructure is to be a true economic engine in the future, network operators must consider low latency, in addition to high throughput, as a key driver in successful broadband network implementation.
- **Strong Public Benefits:** As telecom and mobile operators consider how to build out their networks to reach their service obligations in the rural and remote parts of their countries, governments are also evaluating their role in accelerating deployment of broadband technology to their most needy populations. MEO satellite’s beam flexibility provides governments with an important tool in the fulfillment of their national broadband plans on the ambitious schedules many have announced. In addition, MEO satellite capacity can serve as an easily deployable high–speed communications backbone for disaster recovery efforts, and can provide critical redundancy to long haul fiber cables (either within a country or for submarine cables serving a country).

A connected world enables new levels of understanding, sharing of ideas, and has a pronounced impact on economic growth, knowledge development, and efficient government. This connected world however requires modern and resilient communications infrastructure.

### **Middle range transmission media**

MEO (“medium Earth orbit”) satellite systems are ideally suited to providing “middle mile” trunking and backhaul capacity for national telecom operators, mobile operators, ISPs, large enterprises and government agencies. Because a MEO satellite system is much closer to the Earth than a geostationary satellite, there is a far lower latency in the signals, which is essential for many types of today’s IP–based and broadband services.

With low latency combined with wide bandwidth and high throughput, a MEO satellite system can be the much–needed middle mile in remote and rural areas where traditional terrestrial and geostationary satellite technologies have not or cannot provide the necessary broadband capacity.

### **Satellite Broadband Services**

Within the past few years, satellites have been instrumental in bringing broadband services to users located in areas where terrestrial infrastructure such as xDSL or cable cannot reach, and offering a layer of redundancy for terrestrial links in the case of a disaster or other outage.

### **VSAT**

Countries throughout the developing world are experiencing tremendous growth in VSAT deployments, as e–governance initiatives, corporate networks and rural demand for broadband, television and mobile phone and mobile broadband services also increase. Corporate VSAT networks have become increasingly vital, as companies and their metropolitan and rural workforces depend on reliable and scalable

connectivity for everything from email, Internet and Intranet access. Such networks are also critical in providing redundancy or back up connectivity for critical networks in the case of a disaster or other outage.

Moreover, direct-to-Home satellite broadband is a growing service option for developing countries. Service providers seeking alternative solutions for internet access in rural and remote locations have found satellite broadband to be a compelling solution – and one that is proven and easy to deploy.

Examples of global VSAT networks supporting remote area operations are those of certain United Nations agencies to support activities in missions and field operations worldwide. The UN High Commissioner for Refugees has 7,500+ national and international staff working in more than 350 offices in 110 countries. Most UNHCR operations are in deep field locations where VSAT is the only reliable means of communications for broadband data services.

The UNHCR's Global VSAT network is the satellite component of a Global Wide Area Network (G-WAN), designed to ensure connectivity and redundancy of its operations via multiple components (MPLS IPVPN WAN, VPNs, satellite, etc.) The VSAT network component provides connectivity in 125 of UNHCR's sites in more than 36 countries via 2.4m and 3.8m dishes operating on C-Band or extended C-band capacity. The VSAT network offers both connectivity for remote locations, but also a layer of redundancy or operational continuity in the case of a primary network failure, making the satellite connection a critical component of UNHCR's overall global operations.

### **Community Access Points**

The combination of VSAT and Wireless is an effective solution for many rural applications. Rural populations are often clustered in or around villages with most of the populations within a range of 1 to 5 km. A single VSAT can provide service to an entire village using a wireless local loop solution for the last mile connection. Wireless has the added advantage of spanning rivers or other obstacles and provides a more reliable connection when cable theft is a problem.

One possible solution involves an integrated system of a VSAT, a wireless local loop base station and a solar power system all mounted on a 10 meter post. Such a solution is easy to install, helps overcome obstructions from buildings, addresses power source concerns and is very secure.

The combination of a satellite VSAT connection to the Internet plus WiFi for local access by multiple users can provide the lower per-subscriber costs that the market requires, particularly in rural and remote areas. The satellite connection brings the Internet stream to the village, and WiFi access points extend that connectivity to homes, schools, and public buildings. Users can share both equipment and connection costs through subscription or other joint payment plans.

The keys factors to reducing costs are:

- Use low cost equipment – Off the shelf, open standard equipment (DSL/Wifi/Cable modem) leverages mass production. Integrating satellite equipment that is based on widely-accepted global standards dramatically reduces equipment cost.
- Maximize Subscribers per Gateway – A larger pool of subscribers reduces the equipment cost per subscriber. A larger subscriber base is also more efficient in sharing a single connection. The key issue is to extend the range of standard WiFi equipment to allow a single VSAT to service an entire village.

Such solutions integrate interactive satellite broadband service with the existing last mile infrastructure, such as copper line, TV cable or wireless network. A single central satellite antenna is installed at an aggregation point – i.e. street cabinet in the community, cable TV head-end, or WiFi mast. The broadband connection to the end users is then supplied via the existing last mile infrastructure or the WiFi access, providing all households with internet access at a speed of up to 8 Mbit/s. End users do not have to install a satellite antenna at home, but pay only for a DSL connection and a standard broadband equipment.

### **Satellite broadband deployment example**

Over half of Albania's population is living in rural areas where there are no terrestrial broadband networks. As a part of a government program to bridge these digital disadvantages, the postal institution has brought fast deployable, reliable internet access to its rural offices through a bi-directional broadband solution. 300 out of 550 post offices are equipped with satellite broadband terminals, which allow customers to gain online access and browse the internet, use e-commerce or VOIP telephony and make e-payments for free. At the same time the Albanian Post uses the technology for its day-to-day operations, dramatically cutting costs by using a broadband satellite data network.

Additionally, this same satellite broadband solution is being offered within the confines of the Albanian Ministry of Education in over 300 schools in rural areas. The system allows access to online information, e-learning projects and training to help students bridge the digital divide.

#### **5.6.1.2 Satellite backhaul solutions**

Satellite-based IMT backhaul has played an increasingly important role in extending the reach and coverage of mobile telephony and mobile broadband networks throughout the globe, particularly in developing markets. Advancements in technologies have led to more cost-effective and robust satellite solutions, making them an integral component of mobile network deployment, particularly in rural and remote areas. As governments seek to ensure mobile connectivity for all citizens, satellite backhaul will continue to play a role in providing connectivity to regions where terrestrial-based technologies alone are not an economically viable solution.

Satellite communication forms a key element in the design of cellular infrastructure by providing affordable, reliable broadband backhaul links to the core network. Mobile switching centers and base-station controllers can be connected via satellite, overcoming any barriers of distance, terrain or terrestrial infrastructure and expanding network coverage.

Fixed satellite services can:

- Provide coverage in areas unreachable by terrestrial connections
- Expand network reach quickly with affordable mobile backhaul
- Scale networks as business grows
- Diversify networks

#### **Benefits of satellite backhaul**

Using satellite backhaul to extend broadband services offers benefits in terms of coverage, cost, security and redundancy. Geostationary Earth Orbit (GEO) satellites can provide backhaul services for a large region with only a minimum expenditure on infrastructure. Satellite backhaul solutions enable operators to position base stations where they would provide the most benefit to citizens, with little reference to the location of terrestrial infrastructure. Because fiber build out costs are highly sensitive to distance from the core network and location, the lowest cost solution for backhaul supporting base stations located in rural or remote areas may be satellite.

The use of satellite backhaul also provides redundancy of connectivity. Damage to the fiber backbone network could lead to terrestrial base stations being cut off from key networks, while the extra diversity that satellite backhaul provides will ensure that connectivity remains un-interrupted, even if there is serious damage to terrestrial infrastructure.

As countries increasingly seek to deploy 4G-LTE networks, satellite systems have already been demonstrated through high-throughput satellite backhaul to support these higher bandwidth transmissions.



**Figure 3: Example of geostationary satellite backhauling network**

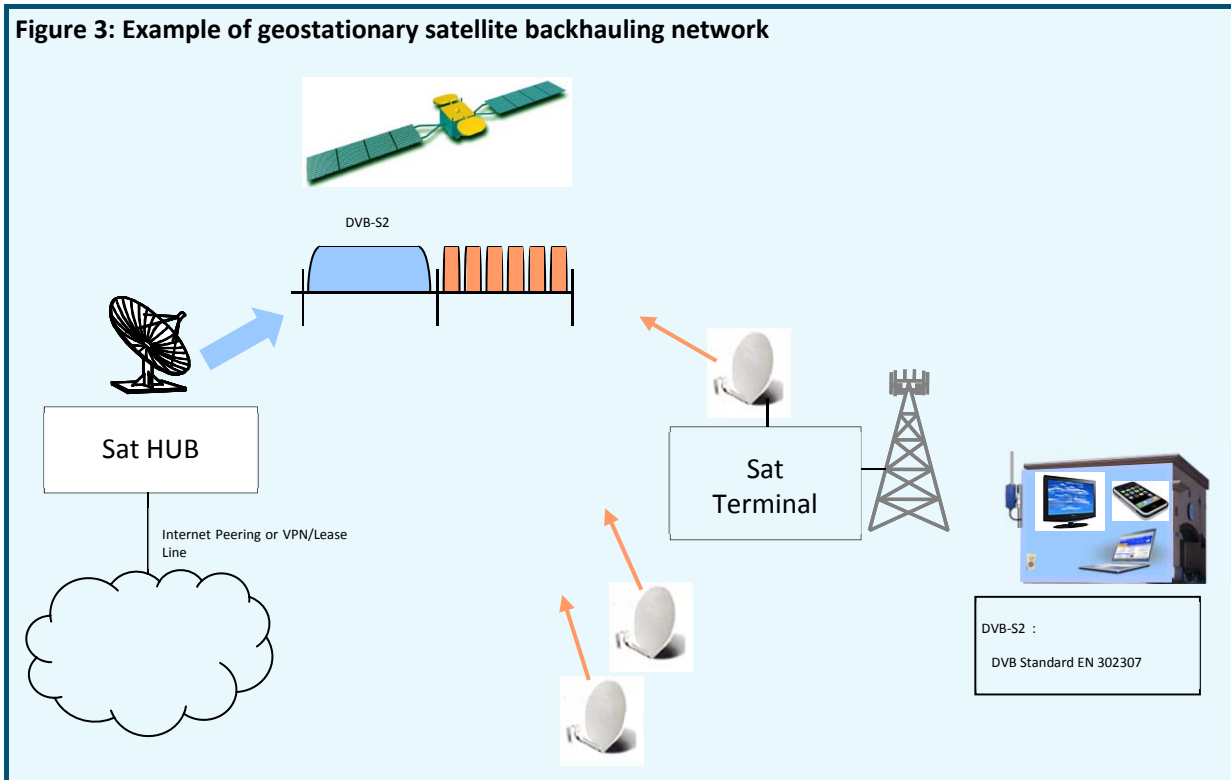

**Medium-Earth Orbit (“MEO”) satellite backhaul**

A MEO satellite system may be ideal for backhaul from remote and isolated areas. The low latency, high throughput, and steerable spot beams combine to provide maximum capacity in targeted areas.

**Figure 4: Example of medium–earth orbit satellite backhauling network**

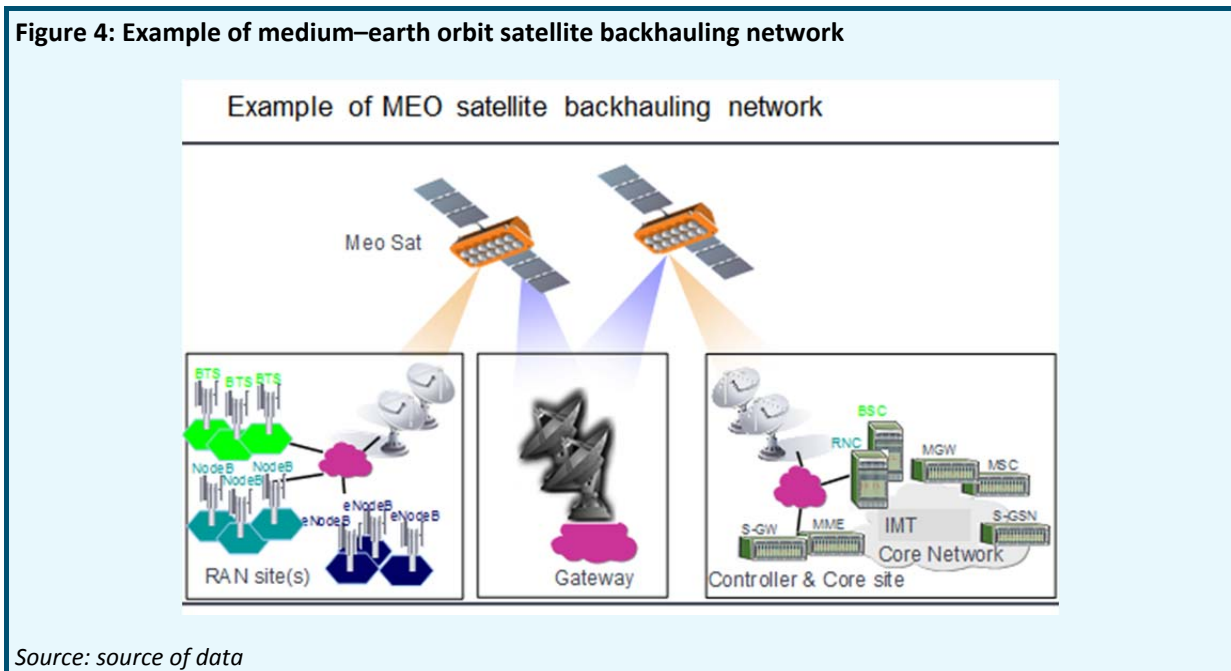

Source: source of data

As mobile penetration rates in populated areas become more dense, mobile operators in developing markets are increasingly using satellite-delivered GSM backhaul to expand their reach further and further into rural markets. Satellite is the only economically viable way to bring capacity to connect the un- and under-connected. With the recent auctions of 3G licenses, and the roll-out of high throughput data services across the networks, backhaul demand is likely to see exponential growth.

### 5.6.1.3 Satellite spectrum considerations

Frequency bands used can impact the size of the dish required and its capabilities:

- C-band (4/6 GHz) transmissions require larger dishes because of the longer wavelength of transmissions in this frequency range. Transmissions in the C-band are less affected by rain fade and other weather conditions because of the highly favorable propagation characteristics of this spectrum. Applications include GSM backhaul, public switched networks, corporate networks, and Internet trunking.
- Ku-band (11–12/14 GHz) has a shorter wavelength allowing for smaller dishes than C-band. However, the higher frequencies make Ku-band more susceptible to atmospheric conditions like rain fade. Applications include VSAT, rural telephony and broadband, satellite news gathering, backhaul links, videoconferencing and multi-media.
- Ka-band (20/30 GHz) has even shorter wavelengths than Ku-band, allowing for even smaller dish size; however transmissions are also even more susceptible to poor weather conditions. High-bandwidth interactive services are possible including high-speed Internet, videoconferencing, and multi-media applications.

### 5.6.1.4 Rural and remote area considerations

Services provided via C-band have been an essential element of the global telecommunications infrastructure. C-band fixed satellite services offer higher reliability and availability than Ku and Ka band networks under rain-fade conditions, and permit broad regional coverage using global beams. For these reasons C-band is generally the frequency band of choice for connecting remote areas of developing countries with wide territories and/or suffering frequent adverse weather conditions.

### 5.6.2 Overview of Dynamic Spectrum Access -based solutions

Dynamic Spectrum Access (DSA) describes a set of technologies and techniques which use smart, radio-enabled, location-aware devices and online databases to enable opportunistic transmission using available, unused radio spectrum on an unlicensed or license-exempt basis. DSA technology allows a radio device to (i) evaluate its radio frequency environment using spectrum sensing, geolocation databases, or a combination of spectrum sensing and geolocation techniques; (ii) determine which frequencies are available for use on a noninterference basis; and (iii) reconfigure itself to operate on the identified frequencies.

In the TV bands, geolocation databases ensure protection from interference to DTT (Digital Terrestrial Television) services, PMSE (Programme Making and Special Events) applications and other incumbent services. Based on a list of all protected frequencies in use, the database identifies suitable channels and instructs the device on which channels, and at what power levels, it may transmit in its current location.

**Figure 5: Example of dynamic spectrum access-based solution**

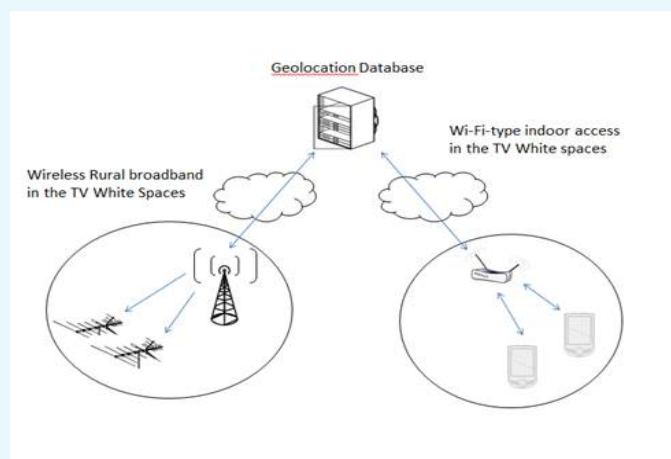

The first globally-harmonized opportunity to use DSA technologies and techniques will be in the TV band “white spaces” – unused, and license-exempt VHF and UHF TV channels that can facilitate wireless broadband access over wider areas than possible using current wifi spectrum. Demonstrations of this technology have been successfully implemented in Belgium, Kenya, Switzerland, Singapore, the United Kingdom, the United States, Uruguay, and other countries. Increasingly, regulators are meeting demand for such technologies through lightly-licensed and license-exempt approaches to maximize spectrum efficiency and enable dynamic technologies to scale inexpensively and with low barriers to entry.

## **6 Summary of the relevant contributions including case-library and e-discussion forum**

The list of contributions relevant to Question 10-3/2 during this study period is available in **Annex 1** to this Final Report. These inputs from the membership were very useful to the study of this Question and of key importance to complete the Final Report.

Rapporteur’s Group collected case studies in each study period and issued the analysis reports to showcase the best practices in the member countries. They also showcase the technologies, solutions, e-applications, funding methods, socio-economic effect, etc. to have empowered the communities in rural and remote areas of developing countries. The best practices will be replicated in the other areas under similar environment of the country or in other countries. During this study period BDT reconfigured the Case Study submission format to be applicable also to other ITU-D study questions. The case studies submitted to Question 10-3/2 in the old format during this study period is being converted to new format by the BDT and will be posted to the new case study library. Accordingly, the ITU-D new case library for Q10-3/2 accommodates the case studies in new case study format.

Rapporteur’s Group has been conducting online discussion for the periods between Study Group 2 and Rapporteur’s Group meetings since there is limitation of time to fully debate the contributions submitted to the meetings or other topics of interests to the members, during the meetings. The online discussion also benefits the members who cannot participate in the meetings due to financial and other constraints. New e-Forum web site was developed by the BDT for this purpose during this study period for all ITU-D Study Group 1 and 2 Questions. The Question 10-3/2 online discussion website was reconfigured to be compatible with new e-Forum on the ITU-D website. The topics of definition of rural and remote areas and the definition of broadband were discussed using the previous version of the online discussion forum and new e-Forum. Many registered members participated in the discussion, which were useful and could be reflected in the Question 10-3/2 group discussions and integrated into the Final Report of the Question. However, as the e-Forum working language is English, there is a language difficulty for those members who are not Anglophone to participate in the discussions. Some measures may be sought to solve this barrier for the future to enable more active participation by all ITU languages by introducing, for example, web translation linked to the e-Forum pages.

## **7 Selected country case studies**

A variety of case studies that were collected during the study period are summarized below. The case studies are also available in the ITU - D Case Study Library. They are national projects, private initiative projects and joint projects, which are all aiming at solving the digital divide. Most of all projects are funded by the national universal fund, international funds or international aid agencies for the start-up. However, operation, maintenance and sustainability of the projects are key issues to be taken into consideration for provision of rural communications services in all cases. Applications such as e-healthcare, e-education, e-administration, e-commerce and other e-services are provided or planned over the Internet protocol platform, WiMAX and GSM network for rural areas in addition to voice services.

Implementation of projects resulted in, in many cases, concerted action or a cooperation between the public and private sectors for technical and regulatory aspects.

## 7.1 Satellite broadband supporting elections in Burkina Faso (Burkina Faso/SES World Skies (Netherlands))

<sup>14</sup>As governments seek to increase transparency and provision of e-services to citizens, ensuring that those e-Government services are accessible to remote and rural areas is essential. Use of technology to support elections is one area where remote access is essential. In December 2012, SES Broadband Services provided satellite broadband services for the parliamentary and municipal elections in Burkina Faso.

As part of the agreement with the Independent National Elections Committee (CENI) in Burkina Faso, SES Broadband Services and its partners Newtec, Access Sat and Unicom provided satellite equipment and bandwidth to enable connectivity between the 45 electoral district offices, which serve as the hubs for 14,698 polling stations across the country, and the central election office in the capital, Ouagadougou. The system was used for video conferencing, video surveillance, Internet access and fast and secure communication of ballots.

SES Broadband Services used satellite capacity on an SES satellite located at 5 degrees east and hardware and hub-infrastructure provided by Newtec. Installations of the VSAT terminals were carried out by Access Sat and the video and the LAN network equipment are supplied by Unicom. In this case, satellite technology was seen as a viable way to ensure connectivity for the remote sites in Burkina Faso with the advantage of quick deployment and immediate coverage and availability. Importantly, the deployed infrastructure will be available after the electoral process to provide Internet access to the Burkina Government aiming at delivering digital services to schools, public offices and remote villages.

The CENI sought satellite services in order to facilitate a transparent electoral process, providing rapid and highly reliable and secure data transfers. The selected satellite VSAT platform offered the advantage of quick deployment for fast transmission of electoral data from remote locations.

Advantages of satellite technology include rapid, secure data collection, aggregation, transfer and verification; a stable, sustainable communication system between all the sites resulting in the improved security of the electoral process, plus the legacy of a top-tier communication system which can be re-used or redeployed. The system in place allowed the results to be declared within a week after the elections and presented to the public almost immediately after the results were determined.

## 7.2 Argentina Conectada (Argentina Connected)(Argentina)

<sup>15</sup>In Argentina the National Telecommunications Plan “ARGENTINA CONECTADA” is a holistic connectivity strategy aimed to reinforce the cross-departmental work among the different government areas. The plan is to be articulated with different public policies, some preexistent, that are currently being executed within the sphere of the National Executive Power, such as:

- Argentine System of Digital Terrestrial Television
- My Digital TV – Access Plan
- Satellite Digital Television
- Digital Audiovisual Nodes Program
- Conectar Igualdad.com.ar Program

---

<sup>14</sup> Satellite broadband supporting elections in Burkina Faso (Link to [Case Study Library](#)).

<sup>15</sup> Argentina Conectada (Argentina Connected) (Link to [Case Study Library](#)).

The objectives and implementation details of the initiative/project applications are:

- To provide backbone fiber coverage to more than 1 700 areas (infrastructure bids are planned)
- To improve the quality of fixed broadband connections, with 10 Mbps per home as quality technological threshold for the new networks.
- To enlarge connectivity of the government agencies at national, province and municipal levels.
- To reach 100% connectivity of public schools.
- To install 2 000 antennas with Internet via satellite connection (reaching rural schools)
- To install 11 000 digital satellite television antennas in public and educational establishments.
- To set up 250 Núcleos de acceso al Conocimiento –NAC (knowledge access centres)
- To multiply the Digital Access Points (DAPs) nationwide.
- Spectrum refarming.
- Satellite internet connectivity for rural families and schools.
- Provision of equipment and digital satellite TV signal to rural and frontier schools.

Financing and partnership is developed by Contributions from the National Budget to ARSAT S.A., a government-owned company

### 7.3 Satellite connectivity plan for rural schools in Argentina (Argentina)

#### Digital TV

<sup>16</sup>Within the framework of its programme to implement open and free-of-charge digital TV, it was develop the National Plan for the equipment of rural and border-area schools with satellite antennas.

This task has involved coordination and joint activities on the part of the Ministry of Federal Planning, Public Investment and Services, the National Communications Commission (a decentralized body thereof) and the Ministry of Education.

The objective is to bring open digital TV channels to rural and border-area schools in Argentina lying outside the coverage area of digital terrestrial TV, using satellite transmission through the digital-to-home (DTH) system.

The total number of educational establishments covered by this state policy within the country's 2 791 810 km<sup>2</sup> land area is some 12 000, accounting for some 1 300 000 pupils and 300 000 teachers.

In turn, those schools in which satellite equipment is already installed are included in a follow-up and monitoring plan, also being conducted by CNC, to determine the degree to which, and how, establishments use the TV content they receive. Of the schools surveyed, 72 per cent are located in rural areas and 28 per cent in urban areas.

#### Internet connectivity

<sup>17</sup>National telecommunications entitled "Argentina Conectada" (Argentina connected) to extend connectivity to Argentine schools in rural and border areas, all in the aim of providing a satellite Internet connection to using VSAT satellite antenna (VSAT).

This strategy was launched as part of the implementation of the national telecommunications entitled "Argentina Conectada" (Argentina connected) to extend connectivity to Argentine schools in rural and border areas, all in order to provide an Internet connection via satellite antennas using VSAT satellite (VSAT).

---

<sup>16</sup> National Plan for the equipment of rural and border-area schools with satellite antennas (Document [RGQ10-3/2/14](#)).

<sup>17</sup> Satellite Internet connectivity plan for rural schools in Argentina (Document [2/160](#)).

This initiative complements the deployment of federal fiber network over Argentine territory, with free installation in nearly 2,500 schools in rural and border areas, fixed antenna to access the Internet connection service VSAT satellite. Students can pursue their learning with access to information technology and communication.

Initially, 2,428 schools in rural and border areas over 141,000 students will be involved in the plan.

The installation began in mid-February 2012 in schools in rural and border areas in the provinces of Neuquén, Río Negro and Chubut, which were affected by the ash emissions from the volcano Puyehue.

There are no representative data on the progress of the installation, recently obtained. However, a pilot implementation of the plan, carried out in sixty schools to date shows that the results are satisfactory.

This public policy is part of a series of measures taken by the Argentine government to ensure digital inclusion by ensuring that technical progress is within reach of all in terms of equality with the federalization of telecommunication services. The use of data services in developing countries is still in its infancy.

#### **7.4 Livelihood opportunities and cultural preservation through a sustainable and eco-friendly ICT telecenter (Marshall Islands)**

<sup>18</sup>The project's aims are:

- To promote actions that will lead to economic growth and help reduce the poor quality of life in Mejit by researching on multimedia services over the broadband IP platform that can be deployed such as local e-commerce, money remittance services, credit card transaction services, e-governance, mobile phone services, and internet services available to the remote island of Mejit.
- To educate the Mejit inhabitants that there is a more efficient way of communicating, for the purpose of business or personal, other than the HF radio and that is broadband solutions in order to attract tourists as well as social welfare of island dwellers, thus promoting tourism, associated investment, empowering the local economy and enriching the life of inhabitants.
- To research on what broadband technology will be applicable to Mejit that will be sustainable and tap into prospected sponsors to kick-start the phase two of the project, which is deployment.
- To encourage the inhabitants that they can utilize technology to preserve the culture of leaf-weaving and rope making and to enrich the next generation population on the isolated island through higher quality basic education of urban standard.

With the pilot project, the society and the government leaders will be aware on the usefulness of ICT in the daily existence of an individual. Through ICT, Marshallese can preserve the culture and stimulating businesses in the area. This pilot project will lead to the installation of ICT telecenters to other locations that are not being services by the telecommunications operator. ICT telecenter is an alternative to rural areas that are digitally disconnected from the internet world.

The regulatory and policy issues are focused on Satellite Access, Electricity Supply, Local Exchange (Available in Majuro only), IP Network, Human Resources, Security.

Due to the economic challenges of the Marshall Islands, MINTA sourced out their equipment from Asia which is more affordable and economical.

---

<sup>18</sup> Livelihood opportunities and cultural preservation through a sustainable and eco-friendly ICT telecenter (Link to [Case Study Library](#)).

The project is financed by an organizations/institutions Partnership (APT, KDDI Foundation, Ministry of Transportation and Communications, Ministry of Education, Ministry of Health, Mejit Atoll Local Government (Mayor and Council), Mejit Senator, Chief and Landowners, Marshall Island Yatch Club, Marshall Energy Company, Marshall Islands National Telecommunications Authority)

## 7.5 Mobile WiMAX in Japan (Japan)

<sup>19</sup>UQ communications is the only company to provide mobile WiMAX services in Japan. 30MHz bandwidth (2595MHz to 2625MHz) in 2.5GHz band was licensed to UQ for their mobile WiMAX service.

Other factors which influenced the operating environment:

- Interoperability across vendors among WiMAX Forum certified devices and infrastructure is well promised.
- UQ WiMAX accelerates their "Open Model".
- Users can choose the devices they want, buy them in their favorite store, activate their plan and cancel it when they want, add another device to their plan, and access all the contents and applications they want.

Subscription: Users no longer have to go the operator's store for subscription. They can subscribe to the service over Internet using OTA (On The Air) application. WiMAX devices/services will be activated, immediately after the OTA application. UQ is providing WiMAX network/platform to many MVNOs (Mobile Virtual Network Operators).

The MVNO approach enables the WiMAX operator to minimize the effort and cost of developing brand, opening retail stores or advertising aggressively.

- MVNOs can prepare their own Device / Terminal.
- MVNOs can decide their own Tariff.
- MVNOs can provide their own Content / Application.
- Many attractive services are created by various industries.

## 7.6 Pilot project for the improved health & medical environment with ICT for rural areas in Lao P.D.R. (Lao P.D.R./Japan)

<sup>20</sup>The project objectives are to implement web video conference system for e-health between central hospital and provincial hospital via network in order to realize the more smooth communication between the doctors.

It is necessary to improve the communication between the doctors in Vientiane and provincial areas for consultation to discuss the status of patients to decide if it is necessary to transport the patients to Vientiane for special treatment or operation.

There is a need for education of nurses and medical engineers in the remote area.

The project is funded by APT (Asia Pacific Telecommunity) and Program: Extra Budgetary Contribution from Japan. Licensing for 15GHz micro radio wave frequency

---

<sup>19</sup> Mobile WiMAX in Japan (Link to [Case Study Library](#)).

<sup>20</sup> Pilot project for the improved health & medical environment with ICT for rural areas in LAO P.D.R. (Link to [Case Study Library](#)).

### **7.7 APT J3 Project: Pilot installation of tele-center for remote education and health-care in rural areas and isolated islands in Micronesia (Micronesia/Japan)**

<sup>21</sup>This project will focused on experimental pilot installation of the telecenter in rural area in isolated islands, where its area is far away from ICT literacy and is hard to understand its benefit and utilization, in such close village life. Therefore, this project shows to people and decision maker in this area about how benefit to gain by growing ICT knowledge and how to maintain the sustainable telecenter.

The Department of Transportation, Communications and Infrastructure in Federated States of Micronesia (FSM) was seeking the implementation of telecenters in order to bridge the Digital– Divide in the islands of FSM as well as between the world outside. In 2006, they launched a project for studying models for telecenters in Micronesia by applying to the Asia Pacific Telecommunity Human Resource Development Program (J2). In the following year they studied the key success factors for a sustainable telecenter with APT expert mission. In 2008, in order to realize the implementation of telecenters in FSM as the next step, a pilot installation project was set up utilizing the APT ICT Development program (J3) and with KDDI participating applying and improving the studied models and key factors.

The project established 5 Pilot telecenters in states (3 islands) in FSM.

1. Kosrae state, Kosrae Island: Walung village elementary school
2. Pohnpei State, Ponpei Island, Madolenihmw district: High school, Elementary school, Municipal Office
3. Chuuk State, Tonoas Island: Sino memorial elementary school

Before the establishment of these telecenters, people in these rural and isolated islands could only keep their traditional economy/knowledge in close society. As a result of this pilot project, they are now considering to connect their economies to outside through ICT. This is the 1st stage of bridging digital divide, respecting their traditional culture and events.

### **7.8 Telecommunications/ICT development by ad-hoc communications network for rural Shiojiri City in Nagano prefecture, Japan (Japan)**

<sup>22</sup>Located in central Nagano, Shiojiri City is situated before a majestic background of mountains fondly referred to as the Japan Alps. However, the city is in a dangerous region because the Itoigawa–Shizuoka Tectonic Line runs north and south through Nagano Prefecture and fault zones gather around the city. As indicated by the national seismic survey, an earthquake with a magnitude of around 8.0 will occur at a probability of 14% in the region within the next 30 years, and the city is located in a region with a harsh natural environment that requires a disaster prevention function.

Regarding such circumstances, and by receiving from Ministry of Internal Affairs and Communications as one of the FY2012 “Project to Promote ICT Town Development” project, the city created an ad–hoc wireless communication network connecting various sensors, with the aim of mitigating disasters, building an enhanced risk management system, and actualizing a safe and secure town to stabilize local infrastructure while locally manufacturing these sensors to contribute to the industrial development of the region.

The system works together with existing FTTH network of Shiojiri, and collects data from the sensors of debris flow detectors, water level detectors, animal infestation detectors, intra–city loop bus tracking detectors, and children and elderly positioning detectors via the ad hoc wireless communications

---

<sup>21</sup> APT J3 Project: Pilot installation of Tele-Center for remote Education and Health-Care in Rural Area and Isolated Islands in Micronesia ([Link to Case Study Library](#)).

<sup>22</sup> Telecommunications/ICT development by ad-hoc communications network for rural Shiojiri City in Nagano prefecture, Japan ([Link to Case Study Library](#)).



network, and accumulates the collected information in a private cloud environment. Also, the project provides mobile terminals and the accumulated data is presented through the Internet, an expanded WiFi network, and area one–segment broadcasting.

The system is useful not only in case of emergency or disaster but in people’s daily lives. The WiFi hotspots and mobile DTV stations is serving as an information point where people can gather information and meet each other.

## **7.9 Mobile Health Information System: Providing access to information for healthcare workers (Project in South Africa /Qualcomm Inc (United States) )**

<sup>23</sup>Every day, people in Sub-Saharan Africa die unnecessarily from infectious diseases, including malaria, tuberculosis, HIV/AIDS, pneumonia and diarrhea. Chronic lifestyle diseases can also burden fragile health systems. Wireless access provided through the project is connecting health care providers to information on preventative measures and healthier living choices, as well as training on the features of the phone.

Wireless Reach is committed to helping local governments reach their Information and Communications Technology (ICT) and universal service goals including increasing teledensity and Internet penetration, as well as using ICTs to meet education, environment and health care objectives.

The goal of the project is to improve access to the latest health information at the point of care so nurses and doctors can better diagnose and treat patients among the Eastern Cape Province populace.

The Mobile Health Information System (MHIS) taps into the power of mobile technology to overcome barriers to Internet access and information poverty. Designed to support the delivery of comprehensive patient care, the mobile library includes digitized medical guidelines, protocols, diagnostic tools and drug formularies to improve patient care.

Striving to enhance the quality of patient care delivery, the FHI 360 team, supported by grants from Qualcomm Wireless Reach and the Henry E. Niles and John M. Lloyd Foundations, designed, planned and implemented the MHIS project. This is a collaborative effort by participating organizations, including the Eastern Cape Department of Health, the Port Elizabeth Hospital Complex, MTN–South Africa, Nelson Mandela Metropolitan University and the project funders.

The MHIS was designed to improve the ability of health care workers in urban and rural settings to care for their patients by providing them with locally relevant, reliable and accurate clinical information accessible using a commercially available mobile device. Each device provides access to a pre-loaded library of clinical and educational resources developed by FHI 360 as well as dynamic Internet content accessed through wireless broadband connectivity provided by MTN–South Africa.

The project provides training sessions, which teach nurses how to use their smartphones to access information and share it with their colleagues. A comprehensive evaluation of the system, carried out by the Nelson Mandela Metropolitan University, showed that enabling nurses to access health resources wirelessly significantly improved their ability to provide care for their patients.

The financing and the technical implementation of the project is provided by different structures: the government, university, network provider (Partnership between government and private sectors). Eastern Cape Department of Health, through its Port Elizabeth Hospital Complex, obtained necessary legal and research approvals, and provides project coordination and technical support for the nurses.

FHI 360 conceptualized the project, serves as the lead implementing partner, created the Mobile Library, and offers training for project participants. MTN, South Africa, as the wireless network provider, offers technical expertise for wireless communication services throughout the project. They are also a co-funder

---

<sup>23</sup> Mobile Health Information System: Providing Access to Information for Health Care (Link to [Case Study Library](#)).

through an in-kind donation, offering equipment and services at below-market costs. Nelson Mandela Metropolitan University, Department of Nursing Science conducted the initial information needs assessment and final project evaluations among the nurses. South Africa Partners provides logistical and administrative support to the project. Wireless Reach provides project management and technical support as well as cash grants totaling more than \$400,000 since 2008. The existing commercial MTN infrastructure was used.

### **7.10 Mobile microfranchising and AppLab initiatives (Project in Indonesia /Qualcomm Inc (United States))**

<sup>24</sup>Implementing partner Grameen Foundation, through its Application Laboratory (AppLab) initiative, is working to establish a multi-tier suite of data services that can be accessed via two distribution channels: (1) via Ruma Entrepreneurs, a human network of mostly women who own and operate mobile microfranchise businesses, and (2) through commercially available phones and the mass market. The core concept of the program is simple, effective and sustainable: a local small-business entrepreneur uses a microfinance loan to purchase a pre-packaged kit that includes a mobile phone and then re-sells the "airtime minutes" to neighbors. The mobile phone then serves as a platform for providing additional applications and services to further increase their revenues and profits. New applications and services are also being launched through a mass-market channel, which directly supports the poorest entrepreneurs.

Indonesia has licensed radio spectrum for 3G mobile services and has established a USO fund (although this fund is not directly accessed by the project, the projects partners may independently access the fund).

### **7.11 Rural and remote areas (Madagascar)**

<sup>25</sup>Various mechanisms are proposed by the countries to finance the development of infrastructure in rural and remote areas. In the case of Madagascar, the state has set up a fund for development of telecommunications and ICT whose purpose is to help finance the development of telecommunications and ICT, as well as access to rural areas not served by extending the service in telecommunications and ICT.

Government grants loans through the fund for projects serving for the implementation of telecommunication infrastructure. To do this, an agreement was established with an operator on the basis of a public-private partnership. The related expenses are provided by the Fund.

### **7.12 Provision of basic telephone services for rural areas (Togo)**

<sup>26</sup>Togo has implemented several programs to develop ICT. The program which is the subject of this contribution is the universal service. Since 2008, the definition of a new strategy of universal service has covered several communities in rural areas in order to make available the basic telecommunications services to the people of these communities.

Since 2008, the new universal service strategy based on a principle of incentives for operators to achieve universal service in return for their financial contributions, returned in force and helped cover several areas in mobile network are: 73 locations in 2008 and 87 locations in 2010. Three other agreements

---

<sup>24</sup> Mobile Microfranchising & AppLab Initiatives (Link to [Case Study Library](#)).

<sup>25</sup> Rural and remote areas (Document [2/162](#)).

<sup>26</sup> Provision of basic telephone services for rural areas (Document [2/188](#)).

signed between the Ministry of Telecommunications operators in May 2012 will cover 2013, 182 other locations.

Operators offer schedules implementation in the agreements. Regular checks are planned during the implementation phase and the time of the recipe sites to completion. These controls are designed to ensure the effectiveness of the presence of basic services in these areas include: voice services, SMS and data (Internet).

During these checks, several observations are made particularly those following:

- the presence of these services encourages rural people to acquire mobile phones despite their very low incomes;
- subscribers face enormous difficulties to maintain their mobile phones. These difficulties include: after-sales service, maintenance and repair of equipment, charging batteries.

The desire to make affordable and accessible communication in rural areas is therefore essential and requires that consideration be given to a strategy to enable the poor to use these services easily and ensuring low maintenance costs.

The problems identified are of two types: from the point of view of the operator and from the point of view of the subscriber. From the subscriber's point of view, this may include:

- places to recharge are placed too far from residential areas and are reduced to the location of infrastructure operators ;
- limited battery life of mobile phones and a large variation between manufacturer: 2, 3 or at the maximum 4 days ;
- limited financial means to have a continuous service.

Apart from difficulties facing rural subscribers, rural networks also have deficiencies which often result in unavailable service. Some examples are listed below:

- the control agent forgetting to start the generator to recharge the batteries for the power installation;
- maintenance problems due to the fact that maintenance is not done in a timely manner, often due to the distance to the city centers where the technicians reside;
- difficulties in re-fueling the generators, etc.

### **7.13 Project of terrestrial wireless broadband connectivity (Burundi)**

<sup>27</sup>This project is a gift from the American Foundation Craig & Susan McCaw. It is produced in cooperation with ITU, and implements a wide band wireless connectivity and ICT applications to provide free or low cost digital access for schools and hospitals as well as a goal underserved populations in rural and remote areas of Burundi.

Cooperating with ONATEL, the government of Burundi will provide the delivery of all required approvals for the project, exempt project equipment of all fees (customs, various taxes), and Assign a bandwidth of 36 MHz for the radio network (2.5–2.7 GHz), while ITU will provide necessary human resources for project management (identification, implementation, supervision, monitoring and evaluation).

The project will setup wireless broadband infrastructure and build Human capacity building to ensure the sustainability of the network.

---

<sup>27</sup> Project of terrestrial wireless broadband connectivity (Document [RGQ10-3/2/5](#)).

### 7.14 Rural ICT Development Project in Iran (Iran)

<sup>28</sup>Islamic Republic of Iran has taken major steps toward its following objectives from 2005:

- Connecting villages to Information and telecommunication networks and providing a global access in rural remote areas.
- Bridging 'digital divide

Funded by Telecommunication Company of Iran (TCI), equipments and facilities as follows have been dedicated to each village:

- A building with: Fire detection (alarm) and fire protection(safety) systems, anti theft systems
- Computer equipments and software application: Router, add/drop devices, personal computer, server, scanner, printer, webcam, telephone, fax, and Internet access at least for each village: 64K
- Post devices: Digital balance, shelves for categorizing the consignments, post box, transportation lines for consignments, bank notes, documents etc.
- Banking devices: Safe deposit, teller, money detector, calculator, printer and required software application

Such equipments and facilities enable:

- Information and telecommunication technology related services: Access to information, news... networks, fixed and mobile services, Internet access and e-government services (such as enrollment list updating, registration of documents, police, registration and course selection for U.E.E entrants... in villages), E-shopping, responding users and visitors of kiosks in all related topics
- Post services: Internal and external letters admissions (both ordinary and custom-built), villagers' products marketing, distributing letters, application forms of national cards, entrance exam registration forms, fuel cards and bills in villages
- Banking services: Inauguration current account, savings account, long term and short term accounts ...), water, power, gas and telephone bills payments, Handling License, passport and other related issues ( Post-Bank)

### 7.15 Energy effective and low cost technology for wireless broadband access and GSM cellular networks (OJSC Intellect-Telecom (Russian Federation))

<sup>29</sup>OJSC Intellect-Telecom (Russian Federation) has developed a technology/method to reduce energy consumption of wireless broadband access and GSM cellular networks by 2-3 times compared to current networks. The technology/method utilizes infrastructure of which is based on a combination of standard base stations (BTS) and relays with capacity transfer (CTR). These are invariant to the technology and the particular standard chosen (GSM, UMTS, CDMA, and so on); repeaters will be chosen in accordance with the standard chosen and will connect to the base station and among themselves. This new technology/method has been implemented for 450 km motor road in Nizhny Novgorod region and the Northern part of the town of Gornoaltaysk in Russia and has resulted in energy saving effect of no less than 2-3 times.

---

<sup>28</sup> Rural ICT Development Project in Iran (Link to [Case Study Library](#)).

<sup>29</sup> Energy effective and low cost technology for wireless broadband access and GSM cellular networks (Document [RGQ10-3/2/INF/07](#)).

### **7.16 The Mawingu Project: Providing broadband access using TV White Spaces in rural Kenya (Project in Kenya/Microsoft Corporation(United States))**

<sup>30</sup>This project – called Mawingu or “cloud” in Swahili – represents the first deployment of TV White Space technology in Africa targeted at communities without access to broadband and focuses on testing the commercial feasibility of delivering low-cost, high-speed wireless broadband access to locations previously underserved. To maximize coverage and bandwidth, while keeping costs to a minimum, the Mawingu network relies on a combination of “unlicensed” or “license-exempt” wireless technologies, including Wi-Fi and TVWS base stations that use complementary spectrum bands including 13 GHz, 5 GHz, 2.4 GHz, and unused UHF TV band spectrum. The initial installation near Nanyuki includes six customer locations: the Burguret Dispensary (healthcare clinic), Male Primary School, Male Secondary School, Gakawa Secondary School, the Laikipia County Government Offices, and the local office of the Red Cross. The installation in Kalema will begin with a base station that connects to a government of Kenya agricultural extension office and 14 more locations on the network will be gradually added.

### **7.17 Evaluating different access technology options (Egypt)**

<sup>31</sup>This case study presents the summary of studies and consultations, and the most quoted reason for lack of NGA commitments was “there are not many applications which would require NGA bandwidths in the foreseeable future. Drivers to NGA are important to understand the incentives for different types of players to enter the NGA field. While some drivers may be universal (appeal for quality business services, increase in bandwidth demand, etc.) they affect different players in different ways. The impact of technology choices on business models essentially lies in two areas: cost optimization and service or evolution limitations. The different approaches and their implications will be presented and evaluated. Co-investment approaches and wholesale models will present proven strategies to enhance the core business model components and their impact on return on investment. Improving the quality of the installed infrastructure (HSPA/ xDSL) might be a short term solution. Implementing LTE, or GPON is the best suitable solution from a mid and long term strategic view.

### **7.18 WiMAX and FiberWiFi Broadband in Rural Areas of Bhutan (Bhutan)**

<sup>32</sup>This pilot project was targeted to study feasibility of deploying FiberWiFi and Alvarion WiMAX broadband in sparsely distributed rural communities and served with 3G, edge or gprs internet service. Pilot project clients in all four geogs (villages) prior to this project were using 3G data card or subscribed to mobile internet to access Internet, and people in these geogs had to travel more than half a day to access Internet. Given the lack of IT literacy and technical know-how in the geogs, for the project connectivity until the customer premises is managed by Tashi InfoComm Limited (TICL). To ensure project sustainability, TICL will manage the business aspect of project without any intervention from department. Though the absence of economy of scale and lack of IT literacy imposed greater challenge to the project implementation, also aggravated by absence of ICT infrastructure to provide Internet service in the communities, Broadband through WiMAX provided easy and fast deployment in the geogs, than utilising fiber optic cables.

---

<sup>30</sup> Mawingu: Providing broadband access using TV White Spaces in Kenya (Link to [Case Study Library](#)).

<sup>31</sup> Evaluating different access technology options (Link to [Case Study Library](#)).

<sup>32</sup> WiMAX and FiberWiFi Broadband in Rural Areas of Bhutan (Link to [Case Study Library](#)).

### **7.19 Fishing with 3G Nets (Project in Brazil/Qualcomm Inc (United States))**

<sup>33</sup>The purpose of this project is to promote the economic and social development of Santa Cruz Cabrália, in southern Bahia, through the digital and social inclusion of fishermen and mariculturists (oyster cultivators who are mostly women). The goal is to use 3G connected smartphones and tablets with a customized application to support mobile education and the development of new economic activities for fishermen, mariculturists) and youth. The current phase will demonstrate how communities can scale the power of 24/7 mobile connectivity to transform learning and create new business opportunities. Qualcomm Wireless Reach has collaborated with partners on the following three phases of the project: Phase I – 3G Connection, Phase II – Diversification of Income, and Phase III – Mobile Education and Technology Innovation. The objectives for each phase complement each other and aim to improve the lives, working conditions, and opportunities for the members of the fishing communities. The project has positively impacted community members of all ages in Santa Cruz Cabralia.

### **7.20 Let's Get Ready! Mobile Safety Project (Project in P.R. China/Qualcomm Inc (United States))**

<sup>34</sup>Sesame Workshop, Qualcomm Wireless Reach, China Telecom Corporation Limited, Guizhou Branch, and China Youth Development Foundation are collaborating to design, implement and scale compelling 3G-enabled interactive content that helps children and their families learn in engaging ways how to better-prepare for possible emergency situations. During the pilot phase, 31 families with children ages 3–6 each received a 3G Snapdragon™ enabled smartphone pre-loaded with the mobile tools, wireless connectivity, a data plan and an approximately hour long, individual orientation to the technology. An HTML 5 website optimized for mobile platforms and accessible to all 3G-enabled smartphones was developed to provide interactive games and activities. After the conclusion of the pilot, in June 2013, the mobile website and the Android application were made available nationally throughout China.

### **7.21 WLAN Coverage solutions in rural China (P.R. China)**

<sup>35</sup>The distribution of broadband users in rural China is dense at micro level while scattered from the macro perspective, and the wired network resource in remote villages is extreme inadequate. Contrary to the fixed broadband access network, WLAN with limited mobility, high bandwidth and low building cost, can be flexibly deployed and utilized, which means WLAN tends to better satisfy the broadband data access demand in rural areas. For villages with dense potential users or high market demand, it is suggested to hang WLAN APs on poles to cover the whole village for ensuring network capacity and user perceptions, whereas for low-demand villages, initially the WLAN can be build on the existing network resources, i.e. covering a village via hanging APs on rural basestation towers + transmitting signals with high gain CPEs, employing basestation APs with high gain antennas and, and other methods can be taken into account after the number of users reaches a certain size at the later stage. Concerning transportation technologies for rural WLANs, due to the context of rural China, the WLAN projects in rural China mostly use PTN technologies (eg ITU-T G.8113.1 and G.8113.2) as the backhaul solution.

---

<sup>33</sup> Fishing with 3G Nets (Link to [Case Study Library](#)).

<sup>34</sup> Let's Get Ready! Mobile Safety Project (Link to [Case Study Library](#)).

<sup>35</sup> WLAN Coverage solutions in rural China (Link to [Case Study Library](#)).

## **7.22 Innovative technological solution for broadband use in rural areas – Data Rural Application Exchange (D-Rax from C-DoT) (India)**

<sup>36</sup>This project customizes the system platform as well as service applications of ICTs in a way to simplify the user interaction and hence be used by the rural population effectively. Here the focus is that the rural masses get connected directly to the ever expanding web of information in a way that is convenient and spontaneous for the rural population. This being the major value differentiator for this product, it is envisaged that this product will bring web of information closer to the masses and will be able to reduce, if not eliminate the evil of digital divide. The platform is deployed in field on a pilot scale and is attracting rave reviews from users.

## **7.23 Successful e-initiative for rural people in remote North Eastern part of India – Active community participation for sustainability (India)**

<sup>37</sup>The contribution briefly analyzes key factors of two successful e-initiative of ICT projects for rural poor in North Eastern part of India, with a view to frame a sustainable strategy for ICT deployment in the backward regions. A project aimed to provide remote tribal villages of Arunachal Pradesh (a North Eastern state of India) with ICT infrastructure for creating e-awareness and e-literacy among the communities was implemented. Ten villages in east Siang district were strategically selected which were located in centre of village clusters, to install e-centres. Also, with a vision to provide quality health care to rural community of Tripura (a north eastern state of India), the tele ophthalmology project was conceived by Government of Tripura aiming to reduce blindness in the state. Key success factors of the project were identified and will be used to make sustainable e-initiatives in the remote and rural part of developing communities.

## **7.24 Case Studies from Broadband Commission Reports**

### **The Digital School Project (Serbia)**

The Digital School Project is the largest national project in the Republic of Serbia to have comprehensively supported digital inclusion in education by equipping all elementary schools with computer labs. Managed and financed by the Ministry of Telecommunications and Information Society, in close partnership with local governments and schools, this project has substantially contributed to enhancing the information society in the Republic of Serbia by increasing the digital literacy of primary education teachers and students, reducing technology fear and anxiety among first-time ICT users, facilitating inclusive education and innovative approaches to teaching, reducing the rural-urban digital literacy gap (currently 11.4% versus 38.9% respectively, with a computer-use rate of 38.3% versus 58.7%), as well as educating all members of society about online safety.

### **Nigeria: Promoting connection of government schools, libraries and institutions**

In Nigeria, funding (US\$100,000 for each school) and support from the Universal Service Provision Fund (USPF) was used for Intel Learning Series Solution (Intel LS) deployments in over 1,000 schools from 2008 to date. One of the mandates for the USPF was to promote the connection of government schools, libraries and institutions across the nation to broadband internet for underserved and rural areas.

---

<sup>36</sup> Innovative technological solution for broadband use in rural areas – Data Rural Application Exchange (D-Rax from C-DoT) (Link to [Case Study Library](#))

<sup>37</sup> Successful e-initiative for rural people in remote North Eastern part of India – Active community participation for sustainability (Link to [Case Study Library](#))

### **Pakistan: Literacy promotion through mobile phones**

This project, based on a proposal by the Islamabad Polytechnic Institute for Women, has been implemented by UNESCO and Mobilink Pakistan together with the Bunyad Foundation. It is monitored by the Federal and Provincial Ministries of Education, the Ministry of IT and Telecom, and the boards of technical education. The aim of the project is to address the low literacy rate of rural females. The project focuses particularly on gender equity, with the goal of increasing literacy rates of rural females through the use of mobile phones.

### **China: Addressing climate risks for farmers**

The livelihoods of billions of poor farmers are threatened by climate-induced risks that affect food security, water availability, natural disasters, ecosystem stability and human health.

China Mobile is addressing the challenges facing poor farmers in China with its Rural Communication and Information Networks. By the end of 2010 89,000 remote villages were part of its mobile communications network, contributing to the national goal of 100% coverage of all administrative villages in mainland China, reached in 2010. More than 19 million rural customers were sending out an average of 19.5 million SMS a day on the Agricultural Information Service by the end of 2010. Automated monitoring and control systems, automatic drop irrigation, wireless water quality monitoring of fresh water aquaculture, and water conservancy are among the ICT applications. Remote transmission of meteorological data provides timely forecasts for the 1,100 monitoring areas in Xinjiang, for example, giving farmers accurate warning in the event of disastrous weather. Through mobile information services, 29 organizations were able to collect and release flood and drought information, and conduct remote monitoring for all 12 regions in Xinjiang. In yet another ICT application, in Fujian, a Rural Microcredit Self-Service Information Platform enables farmers to apply for loans from their handsets or rural information terminals by SMS, making the loan application and the approval process paper-less.

Gaps in broadband penetration and affordability persist not only among countries, but also between rural and urban areas within a nation. The digital divide remains a stubborn obstacle to progress.

### **Rwanda and India: From push to pull**

Rwanda for example—one of the few African countries that developed an integrated ICT policy in the late 1990s—has a universal access fund aimed at balancing urban and rural usage and enhancing community access to ICT.

In India, The National e-Governance Plan is ‘dematerializing’ administration around the country by transferring an increasing proportion of government services online, creating nation-wide demand for ICT. An m-governance policy<sup>41</sup> has been drafted to provide services via mobile phone, including basic banking. Services from school or college admission to pension payments and primary health services will all be accessible online. Key social sector ministries like Education, Health and Rural Development also have ambitious digitization, content creation and e-service delivery programs and projects underway. All of this will serve to increase uptake of broadband-based services, while reducing CO<sub>2</sub> footprint and enhancing social inclusion.

### **Tanzania: African great lakes rural broadband research infrastructure**

The Tanzania ICT for Rural Development programme<sup>25</sup> is a research effort on inclusive ubiquitous broadband access. The programme has launched first mile initiatives to explore strategies for the establishment of broadband markets in rural areas where there is demand but no supply due to high perceived risks. A successful strategy has been to attract investments by focusing on basic public services in healthcare, drug security, education and local government supporting progress towards the Millennium Development Goals, and then turn every stone to find customers to sustain the broadband network and services. The challenges include design of robust network components, dealing with poor or non-existent power supply, strengthening weak supply chains and development of sustainable business models. The planning of a next phase extending the programme in the African Great Lakes region is in progress.



## 7.25 Analysis of selected case studies

### 7.25.1 Policy and regulatory solutions

To establish a policy and regulatory framework for the deployment of broadband connectivity, it should consider the following questions, which can be grouped into two broad categories: issues and supply issues on demand. From the supply side, infrastructure development plays a central role:

- **Use of funds for the USO for the implementation of broadband networks:** The use of this fund to create or develop a national fiber optic network capacity will be economically advantageous for suppliers 'broadband infrastructure.
- **Promoting competition in markets:** The strict application of rules of fair competition and the introduction of new safeguards will be crucial for the provision of broadband services.
- **Firm application of rules of fair competition** and the introduction of new safeguards will be crucial for the provision of broadband services: Access to additional radio spectrum at reasonable prices: It will be important to ensure that the scarcity of frequencies does not lead to excessive prices. It is possible to achieve this by improving the terms of the auction for the allocation of portions of the spectrum
- **Use of interconnection charges to encourage the creation of infrastructure:** The application of higher access to rural subscribers' termination charges would be an incentive for investment in rural areas.
- **Need for wireless access using a high-capacity backbone infrastructure**
- **Facilitating the acquisition of rights of way:** The anticipated funding broadband infrastructure in rural areas by government agencies, including the funds for the USO, can be crucial to the challenge posed by the need to obtain rights of way across the country.
- **Grants to end users:** Access to broadband at affordable prices can encourage recipients to subscribe to broadband and use.
- **Grants to Service Providers:** Grants service providers for infrastructure development are much more effective than those designed to fund operating expenses in order to lower prices to end users.
- **Cross-subsidization between broadband and other services:** Forcing service providers to practice great rates for broadband access while giving them the opportunity to offset their losses by allowing them to increase the tariffs of other services such as voice calls and homelessness, or to lower interconnection rates, may allow operators to increase their profits and contribute to the commercial viability of broadband service providers.
- **Regulatory initiatives** should be designed to allow operators to deploy networks, launch new services in rural and remote areas. It is important to have incentives to interested operators or attract investors. Must be put in place accompanying facilities when operators deploy networks in rural and remote areas.
- **Creating an access funds** and services was passed through several countries to subsidize operators wishing to install infrastructure and services in rural areas. Regulators and policy makers should take all ICT initiatives by implementing appropriate as a means to encourage the expansion of telecommunications services to rural and remote areas regulatory structures. It is mentioned in the Objective 2 Connect Africa Summit that all African villages should be connected to ICT services by 2015.

### **7.25.2 Proposed measures and actions**

- Set up ICT facilities in rural and remote areas of developing countries to slow the exodus.
- A regulatory framework that better adapt to the rapidly changing environment of new technologies and new services should be established in each country, so as to develop ICT in rural and remote areas.
- The costs imposed by the government for the provision of telecommunication services including customs duties on imported equipment must be lightweight to reduce direct financial support to service users.
- There is a need in rural and remote areas, facilities for power.

The government, as policy makers, must be aware of the strategic role of the development of telecommunications in rural and remote areas.

- Share experiences of developed countries in this field with others;
- Promote the use of renewable energy;
- Promote equipment manufacturing to lower energy consumption can operate with solar and / or wind;
- Set up in the achievements of universal service system battery charging phones free or at a reduced price in the affected areas;
- Encourage collaboration between the Ministry of Telecommunications and the Ministry of Energy for common actions to make available in the regions two networks: electricity and telephone;
- Consider if possible to increase the battery life of phones by manufacturer;
- Promote the manufacture of solar devices;
- Promote the development of solar batteries;
- Promote the development of solar chargers; etc.

## 7.26 List of technologies, applications and funding in ITU-D SG2 Q10-3/2 case studies

Table 6 List of technologies, applications and funding in ITU-D SG2 Q10-3/2 case studies

No	Country	Title	Technologies	Applications	Funding
1	Burkina Faso (project by SES World Skies, Netherlands)	Satellite broadband supporting elections in Burkina Faso	Satellite (VSAT)	Video conferencing; Video surveillance; Internet access; Fast and secure; communication of ballots	National budget
2	Argentina	Satellite Internet connectivity plan for rural schools in Argentina	VSAT	Data (internet)	National fund (Based on National Telecommunication Plan)
3	Marshall Islands	Livelihood opportunities and cultural preservation through a sustainable and eco-friendly ICT telecenter	Fiber optic cables (Submarine) Satellite GSM (cellular) Wifi and Femto-cell	e-learning e-health telephony and mobile phone and Internet access	APT Grant Governmental support (in-kind and telecenter construction)
4	Japan (Project by KDDI Corporation, Japan)	Mobile WiMAX in Japan	WiMAX	Any kind of (data) applications including VoIP (voice)	Commercial (No funding from government)
5	Lao P.D.R. (Project by Fujitsu Limited, Japan)	Pilot project for the improved health & medical environment with ICT for rural areas in Lao P.D.R.	Terrestrial Wireless 15GHz	e-health application for government Voice, video, picture transmission	Funded by APT grant
6	Micronesia (Project by KDDI Corporation, Japan)	Pilot installation of Tele-Center for remote Education and Health-Care in Rural Area and Isolated Islands in Micronesia	Wired local loop: Copper Wireless local loop Fixed wireless access (long distance) Wireless LANS and IP-based related networks	E-health Tele-education e-learning ICT training	Funded by APT Grant
7	Japan	Telecommunications/ICT development by ad-hoc communications network for rural Shiojiri City in Nagano prefecture, Japan	FTTH Ad-hoc wireless network Wi-fi DTV (one-segment mobile broadcasting) Sensors (Water level, children and elderly positioning, etc.)	Emergency telecommunication E-agriculture (Animal detection) Bus tracking Children and elderly positioning	MIC (Ministry of Internal Affairs and Communication), Japan

Q10-3/2: Telecommunications/ICTs for rural and remote areas

No	Country	Title	Technologies	Applications	Funding
8	South Africa (Project by Qualcomm Incorporated, United States)	Mobile Health Information System: Providing Access to Information for Health Care Workers	3G Cellular network (existing network)	Access to a pre-loaded library of clinical and educational resources Dynamic Internet content accessed through wireless broadband	Qualcomm Wireless Reach Henry E. Niles and John M. Lloyd Foundations MTN, South Africa (in-kind)
9	Indonesia (Project by Qualcomm Incorporated, United States)	Mobile Microfranchising & AppLab Initiatives	CDMA2000 broadband mobile network to carry SMS, telephony and IP based data	Brew (mobile operating system to allow the development and deployment of application-based services) Development and deployment of SMS and IP based applications.	Qualcomm Wireless Reach USO fund (projects partners may independently access the fund)
10	Madagascar	Rural and remote areas	Satellite, optical fiber, WiMax	NA	State fund (Telecommunication/ICT development fund)
11	Togo	Fourniture des services de base en téléphonie dans les zones rurales (Provision of basic telephone services for rural areas (Togo))	Mobile technology (cellular)	Voice, SMS, data (Internet)	Incentives to operators (Universal service)
12	Burundi	Projet de connectivité hertzienne large bande (Project for terrestrial wireless broadband connectivity)	Wireless Broadband	e-learning (connect schools) e-health (connect hospitals)	Craig & Suzan McCAW Foundation ITU (in-kind) Government of Burundi
13	Iran	Rural ICT Development Project in Iran	Multiple technologies (for Internet access)	e-government e-shopping e-banking postal services	Telecommunication company of Iran(TCI)
14	Micronesia (Project by KDDI Corporation, Japan)	Pilot installation of Tele-Center for remote Education and Health-Care in Rural Area and Isolated Islands in Micronesia	Wired local loop: Copper Wireless local loop Fixed wireless access (long distance) Wireless LANS and IP-based related networks	E-health Tele-education e-learning ICT training	APT Grant
15	OJSC Intellect-Telecom (Russian Federation)	Energy effective and low cost technology for wireless broadband access and GSM cellular networks	Wireless Broadband Mobile technology (cellular)	System can carry any voice/data	

No	Country	Title	Technologies	Applications	Funding
16	Kenya	The Maginwu Project: Providing broadband access using TV White Spaces in rural Kenya	Wireless Broadband	Internet access e-learning (connect schools) e-health (connect clinics) e-government (connect government offices)	Microsoft USAID Indigo Telecom
17	Egypt	Evaluating different access technology options	Wireless (HSPA/HSPA+, LTE, Wimax) Wireline (DSL, PON)	Broadband	
18	Bhutan	WiMAX and FiberWiFi Broadband in Rural Areas of Bhutan	WiMAX WiFi	Internet access	APT Funding (J3)
19	Brazil (Project by Qualcomm Incorporated, United States)	Fishing with 3G Nets	UMTS/WCDMA mobile network	SMS, Telephony, and Data Smartphone	Qualcomm Wireless Reach Telefonica Vivo Foundation USAID
20	China (Project by Qualcomm Incorporated, United States)	Let's Get Ready! Mobile Safety Project	CDMA2000 1x / EV-DO mobile network	SMS, Telephony, and Data Smartphone	Qualcomm Wireless Reach
21	China	WLAN Coverage solutions in rural China	PON, PTN and MSTP (including wireless)	Internet access, etc...	
22	India	Innovative technological solution for broadband use in rural areas – Data Rural Application Exchange (D-Rax from C-DoT)	EV-DO DTV Wide area network MPLS	e-Agriculture e-Health	Government of India
23	India	Successful e-initiative for rural people in remote North Eastern part of India – Active community participation for sustainability	Internet	e-government, e-education, etc... (multi language platform for users without ICT skillsets)	Government of India

## 8 Conclusions and Recommendations

The Rapporteur's Group studied Question 10–3/2 by contribution, inputs of case study and questionnaire replies from membership and the e-forum online debate was conducted between the meetings which take place twice a year, namely Study Group 2 meeting in autumn and Rapporteur's Group meeting in spring every year.

There are rapidly emerging technologies some of which are applicable to the rural and remote areas under harsh environment as mentioned above. Collected case studies showed these technologies implemented for the multimedia services and applications in rural and remote areas of developing countries.

Two major technologies observed in the case studies are the terrestrial wireless technology such as WiFi, WiMAX and CDMA and the satellite technology such as VSAT coupled with geostationary satellite (GEO) observed in collected case studies. Recently, medium orbit satellite (MEO) service is launched and proposed to ITU-D SG2 for providing cost effective and low latency broadband services for rural and remote areas. Those two technology options are expected to be suitable from the point of cost effectiveness compared with other technology options.

Himalayan Mountain Village Network is the typical example of terrestrial wireless network providing multimedia services, internet connectivity to schools, health posts and bulletin board news services in mountain villagers where no newspaper is available. VSAT plus GEO technology option is observed in the case study submitted by a Pacific Small Island Developing State (SIDS). It seems that satellite technology is most suited for connecting cost effectively outer islands in SIDS. Optic fiber technology is expected to provide stable broadband service to rural and remote areas however it is not always meeting the requirements of cost effectiveness for communication infrastructure of rural and remote areas. Optical Ground Wire or Optical Fiber Composite Overhead Ground Wire (OPGW) is implemented in one of the case studies submitted by a LDC which is considered suitable for broadband network of rural and remote areas.

**Definition of rural and remote areas** was discussed during Rapporteur's Group meeting and e-forum and online discussion. Many countries responded to BDT questionnaires define rural and remote areas in their national development policy by sparseness of population in the areas.

**Definition of broadband** was discussed in the e-forum about the minimum requirement of data speed of upward and downward respectively such as 64Kbps/128Kbps, 128Kbps/256Kbps, or 256Kbps/512Kbps as the various services are rapidly emerging. Broadband commission report presented to the rapporteur's group meeting of SG2 September 2012 concluded that broadband could not be defined by the data speed as the technology advances rapidly and services are emerging implemented in the rural and remote areas of the developing countries. The report concluded that broadband is an always on service (not needing the user to make a new connection to a server each time) and high capacity: able to carry lots of data per second, rather than a particular speed. It also concluded that the broadband enables the combined provision of voice, data and video at the same time. There are several countries responded to the BDT questionnaires about the various data speed of broadband services, however, some countries indicated download data speed of 2Mbps to be defined in their national policy or more higher speed in other country over their optical fiber networks.

### **Acknowledgment**

The Rapporteur, Mr Yasuhiko Kawasumi, Ministry of Internal Affairs and Communications, Japan appreciates the Vice-Rapporteurs, volunteers and BDT Focal Point for Question 10-3/2, BDT staff for their collaboration to complete this final report. Rapporteur also appreciates Member States, Sector Members, Associates, Academia who submitted input contributions and their participation for the work of the Rapporteur's Group for Question 10-3/2 during this study period.

### **Vice-Rapporteurs for the Q10-3/2 who contributed to the final report:**

- Mr X. Si (People's Rep. of China)
- Mr N. Njekoundade (Chad)
- Mr N. Albi (Aggaros, Spain)
- Ms S. Yildirim (Turk Telecom, Turkey)
- Mr Y. Avanesov (OJSC Intellect Telecom, Russian Federation)
- Mr R. Anago (Burkina Faso)

- Ms R. Assoumou–Bessou (Côte d’Ivoire)
- Mr A. R. Khanal (Nepal Telecommunications Authority, Nepal)
- Mr R. Alabatena (Cameroon)

**Additional volunteers who expressed to participate in drafting the final report**

- Mr R. Joshi, Nepal Telecom (Nepal)
- Dr M. Zennaro, ICTP (Italy)
- Mr P. Kelley, Alcatel Lucent (France)
- Dr L. Patnaik, Qualcomm (United States of America)
- Mr J. B. Rwagatare (Rwanda Utilities Regulatory Agency, Rwanda)
- Mr T. Muluk, Intel Corporation (United States of America)
- Dr V. Rawat (Research in Motion Ltd., Canada)
- Ms B.Otgonchimeg (Mongolia)
- Mr I. K. Maiga (Mali)
- Mr S. Diarra (Mali)

**BDT focal points who contributed for drafting the final report**

- Ms J. Koizumi (2010–2012)
- Mr T. Sugimoto (2012–2014)

## 9 Acronyms and abbreviations

<b>APT</b>	Asia Pacific Telecommunity
<b>BDT</b>	Telecommunication Development Bureau
<b>BTS</b>	Base Transceiver Station
<b>CDMA</b>	Code Division Multiple Access
<b>CPE</b>	Customer–premises equipment
<b>DSL</b>	Digital subscriber line
<b>FSS</b>	Fixed Satellite Service
<b>FTTx</b>	Fibre–To–The–x (Building, Curb, House ...etc.)
<b>GDP</b>	Gross Domestic Product
<b>GHG</b>	Green House Gas
<b>GPS</b>	<b>Global Positioning System</b>
<b>GSM</b>	Global System for Mobile communications
<b>GSO</b>	Geo–Stationary Satellites
<b>ICT</b>	Information and Communication Technologies
<b>IEEE</b>	Institute of Electrical and Electronics Engineers
<b>IP</b>	Internet Protocol
<b>ISP</b>	Internet Service Provider
<b>LAN</b>	Local Area Network
<b>LDC</b>	Least Developed Country
<b>LTE</b>	Long–Term Evolution
<b>MDG</b>	Millennium Development Goal
<b>MEO</b>	Medium Earth Orbit
<b>MPLS</b>	Multi–Protocol Label Switching
<b>OAM</b>	Operation, Administration, and Management
<b>P2P</b>	Point To Point
<b>PMP</b>	Point to Multi–Point
<b>PON</b>	Passive Optical Network
<b>PSTN</b>	Public Switched Telephone Network
<b>SDH</b>	Synchronous Digital Hierarchy
<b>SIDS</b>	Small Islands Developing States
<b>SMS</b>	Short Message Service
<b>UNESCO</b>	United Nations Educational, Scientific and Cultural Organization
<b>UNHCR</b>	United Nations High Commissioner for Refugees
<b>USF</b>	Universal Service Fund
<b>USO</b>	Universal Service Obligation



<b>VoIP</b>	Voice over Internet Protocol
<b>VPN</b>	Virtual Private Network
<b>VSAT</b>	Very Small Aperture Terminal (used with satellite systems)
<b>WDM</b>	Wavelength–Division Multiplexing
<b>WiFi</b>	Wireless local area network (WLAN) products based IEEE 802.11 standards
<b>WiMAX</b>	Worldwide Interoperability for Microwave Access
<b>WSIS</b>	World Summit on the Information Society
<b>WTDC</b>	World Telecommunication Development Conference

## 10 References

- 1) A 2010 Leadership Imperative: Future Built on Broadband; A report by the Broadband Commission, 2010, [www.broadbandcommission.org/Reports/Report\\_1.pdf](http://www.broadbandcommission.org/Reports/Report_1.pdf)
- 2) TRAI Recommendations on Application Services, May,2012
- 3) Laschewski, Lutz, "Innovative E-learning in Rural Areas: A Review. Network Promoting e-Learning for Rural Development, e-Ruralnet;LLP Transversal Program Key Activity 3 ICT – Networks
- 4) Myrvang, Robert and Rosenlund, Thomas "How can e-Health benefit rural areas– a literature overview from Norway", April 2007
- 5) From E-government to M-government: Facing the Inevitable; Ibrahim Kushchu International University of Japan and M. Halid Kuscü Southwestern College, School of Business and Information Systems
- 6) J.Segel, M. Weldon, Alcatel-Lucent Technology White Paper "Light Radio" (2011) ([www.alcatel-lucent.com/features/light\\_radio/index.html](http://www.alcatel-lucent.com/features/light_radio/index.html))
- 7) Gang Shen, Jimin Liu, Dongyao Wang, Jikang Wang and Shan Jin, "Multi-hop relay for next-generation wireless access networks" (2009), Bell Labs Technical Journal, Volume 13, Issue 4, pages 175–193 Volume 13, Issue 4 (<http://onlinelibrary.wiley.com/doi/10.1002/bltj.v13:4/issuetoc>)
- 8) The Missing Link Report: Report of Independent Commission for World Wide Telecommunication Development, 1985, ITU Publication Department
- 9) The Final Report of Focus Group 7 on Topic 7: New Technologies for Rural Applications, 2001, ITU–D SG2, ITU Publication Department
- 10) ITU News No.7, September 2001:Connecting Rural Communities, Multimedia services for rural areas using wireless IP technologies
- 11) ITU News Special Issue No.2, March 2002:Challenges for rural communications development, The legacy of the Maitland report
- 12) Report of the Rapporteur's Group on Q10–1/2, ITU–D SG2, October 2004: Analysis of Replies to the Questionnaire on Rural Communications (findings, analysis and tabular information) down loadable free of charge from [www.itu.int/md/D02-RGQ10.1.2-C/e](http://www.itu.int/md/D02-RGQ10.1.2-C/e)
- 13) Report of the Rapporteur's Group on Q10–1/2, ITU–D SG2, Doc. 2/270 September 2005: "Analysis of Case Studies on Successful Practices in Telecommunications for Rural and Remote Areas" down loadable free of charge from [www.itu.int/pub/D-STG-SG02.10.1-2006/en](http://www.itu.int/pub/D-STG-SG02.10.1-2006/en)
- 14) Recommendation ITU–D 19: Telecommunication for rural and remote areas: Downloadable free of charge from [www.itu.int/dms\\_pubrec/itu-d/rec/d/D-REC-D.19-201003-!!PDF-E.pdf](http://www.itu.int/dms_pubrec/itu-d/rec/d/D-REC-D.19-201003-!!PDF-E.pdf)
- 15) Maitland +20 Book, Fixing the Missing Link, Published in UK by the Anima Centre Limited, 2005, 1 Wine Street Terrace, Bradford on Avon Wiltshire BA15 1NP, England. Tf:+44 1225 866612, E-mail: [team@theanimacentre.org](mailto:team@theanimacentre.org), [www.theanimacentre.org](http://www.theanimacentre.org)
- 16) WSIS Outcome Documents, December 2005 Downloadable free of charge from [www.itu.int/pub/S-POL-WSIS.OD-4-2006/en](http://www.itu.int/pub/S-POL-WSIS.OD-4-2006/en)
- 17) WSIS Golden Book February 2006 [www.itu.int/pub/S-POL-WSIS.GB-2005/en](http://www.itu.int/pub/S-POL-WSIS.GB-2005/en)
- 18) World Information Society Report 2007: Beyond WSIS: Executive Summary is down loadable free of charge from [www.itu.int/pub/S-POL-WSIS.RPT-2007/en](http://www.itu.int/pub/S-POL-WSIS.RPT-2007/en)
- 19) ITU News No. 5 June 2007: A case study in rural telecommunications, ICT arrives in a Bhutanese village
- 20) Revised Analysis Report of Case Studies 2009: Analysis of case studies on successful practices in telecommunications for rural and remote areas (II): Downloadable from [www.itu.int/md/D06-SG02-C-0250/en](http://www.itu.int/md/D06-SG02-C-0250/en)

- 21) ITU News No.6 July–August 2009: Himalayan villages go online, The Nepal wireless networking project
- 22) ITU News No. 7 September 2010: Remembering Donald Maitland, The missing link report: the Maitland legacy
- 23) ITU Publication 2011: Handbook for the Collection of Administrative Data on Telecommunications/ICTs
- 24) A Report by the Broadband Commission September 2012: The state of Broadband 2012: Achieving Digital Inclusion for All
- 25) ITU Publication September 2012: IP Backhaul and Access Network
- 26) ITU Publication 2012: Measuring the Information Society
- 27) Joint publication by World Bank and ITU 2012: The Little Data Book on Information and Communication Technology 2012



## **Annexes**

**Annex 1: List of input contributions during the study period 2010-2014 and their summaries**

**Annex 2: Analysis of questionnaire replies for the global survey on policy initiatives/interventions on telecommunications/ICTs/broadband development**



## Annex 1: List of input contributions during the study period 2010-2014 and their summaries

List of contributions submitted to Question 10-3/2 (for action)					
No.	Date	Source	Title	Abstract	Remarks
<a href="#">2/002</a>	12– Jul–10	OJSC Intellect Telecom (Russian Federa- tion)	Cellular telecommu- cation network with capacity transfer. Study Question 10 2/2 – Telecommu- nications/ ICT for rural and remote areas	In accordance with the theme of Step 1 of study Question 10-2/2, it is proposed that a study should be made of one of the methods of tackling the task defined by ITU using a “cellular communication system with capacity transfer”.  The proposed solution is the project “Cellular telecommunication network with capacity transfer”. This uses the latest technologies that have been developed with a view to reducing capital and operating costs. Use of this solution wherever possible promotes convergence between services and applications, and reduces energy consumption and greenhouse gas emissions.	New technology (broadband wireless)
<a href="#">2/25</a>	31– Aug– 10	China (People’s Republic of)	Draft Proposal on Research Plan of Telecommuni- cations for rural and remote areas	The text proposed a research plan in 2011–2014 for the Question 10-2/2 on “telecommunications for rural and remote areas”.	Research plan
<a href="#">2/40</a>	10– Sep– 10	KDDI Japan	Pilot installation of Tele–Center for remote Education and Health–Care in Rural Area and Isolated Islands in Micronesia	This contribution provides the graphical information for the project called “Pilot installation of Tele–Center for remote Education and Health–Care in Rural Area and Isolated Islands in Micronesia” to supplement the text information which is the only way we can use currently to report the project on the “Case Library for Rural Communications” in ITU–D Web site. This contribution also proposes the upgrade of “Case Library” function, enabling the use of graphical information.	Case study (e–education, e–health)
<a href="#">RGQ10- 3/2/3</a>	15– Feb– 11	Nepal Telecommu- nications Authority	Policy and Regulatory Intervention for Telecom Growth in Rural Nepal	Due to her very peculiar topography, Nepal poses a great challenge for the development of telecommunications and ICT infrastructures. Other socio–economic and cultural indicators also do not directly support the uses and adoption of relatively newer telecommunications and ICT services. It is evident from the government targets set through the three consecutive development plans–the ninth and tenth five– year and the interim three– year development plans adopted by the Government of Nepal which aimed to achieve the availability of two telephone lines in each of the 3915 Village Development Committees (VDCs). These targets were met only by the end of the three–year interim plan (FY 63/64–66/67). This target was achieved not as a matter of course–but because of the fact that there were several policy and regulatory interventions made by the Government of Nepal and the Nepal Telecommunications Authority (NTA). This story highlights the importance of specific policy and regulatory interventions for telecom growth in rural Nepal.	Case study (universal access)

List of contributions submitted to Question 10–3/2 (for action)					
No.	Date	Source	Title	Abstract	Remarks
				However, such government and regulatory initiatives are not without criticisms from different corners specifically from the perspectives of transparency, professionalism, efficiency and independence of such initiatives. In this paper we highlight some of the major initiatives made by the government and the regulator and the objectives achieved.	
<a href="#">RGQ10-3/2/4</a>	16–Feb–11	Nepal Telecommunications Authority	Rural Challenges: Telecommunications/ICT Development Perspectives	Rural and remote areas of most of the developing countries are characterized by difficulty in accessibility by any means of transportation either ground or air, absence of national grid for electricity, absence of any kind of skilled human resources, low literacy, sparsely populated areas with lower population density, absence of good health care facilities, no employment opportunities, low paying capacities of the people, no access to information sources resulting in the lower socio-economic indicators as well as lowest state of infrastructure development. When these indicators are low, they have direct or indirect impact on the development of telecommunications/ICTs in such areas. The major stakeholders in the entire telecommunications/ICT value chain and ecosystem face a number of challenges from their own perspectives when they want to contribute to the development of telecommunications/ICTs in the rural and remote areas of developing countries. In this contribution, we have identified the government, the regulator, the telecom service providers, the CPE manufacturers, the infrastructure manufacturer (vendors), the VAS providers, the content developers, the bilateral and multilateral donor agencies, the civil society organizations, the consumers etc., as the major stakeholders in the telecommunications/ICT value chain. Each one of them face specific challenges from their own perspectives and these challenges are enumerated in this paper. During the next five years we have to work hard to achieve the targets set in the WSIS Action Plan and the related action lines. The way forward to address these challenges is also recommended.	Case study (stakeholder analysis)
<a href="#">RGQ10-3/2/5</a>	22–Feb–11	Burundi Ministry of Telecoms, Information, Communication and Relations with Parliament	Connectivity project broadband wireless	The project is a gift to the Foundation Craig & Suzan McCaw and consists of: <ul style="list-style-type: none"> <li>– Deployment of broadband infrastructure in identified areas in Burundi, by mutual agreement with the ITU</li> <li>– The development of ICT applications</li> <li>– Training of local experts to operate the installed network</li> <li>– The development of a national plan to deploy a broadband ICT network providing free or inexpensive to underserved populations in rural and remote areas.</li> </ul>	Case study (broadband wireless)



List of contributions submitted to Question 10–3/2 (for action)					
No.	Date	Source	Title	Abstract	Remarks
<a href="#">RGQ10-3/2/6</a>	25–Feb–11	Uganda Communications Commission	Universalizing Access to ICTs for Social and Economic Development: Lessons and Experiences learnt from Uganda	This paper attempts to analyze Uganda’s experiences with regard to her universal access policy and objectives. The objective is to derive best practices that Uganda and other developing countries may consider adopting in their quest to improve delivery of ICT services in the underserved areas in order to stimulate social and economic transformation of the rural areas. The paper contends that an effective policy and regulatory framework has been the cornerstone to driving universal access agenda to ICTs in Uganda. However, in order to move a sustainable universal access policy, the requirement for effective problem definition, feasibility analysis and objectives setting that are in line with the local conditions is of critical importance. In doing this, consideration should be taken to build in synergy and developing partnerships with other stakeholders. This should be followed by formulation of the business concept even though the initiative is for commercial and/or meeting social obligations.	Case study (universal access)
<a href="#">RGQ10-3/2/7</a>	28–Feb–11	Chad	The development of telecommunication/ ICTs for rural and remote areas in Chad	In Chad, telecommunications development is primarily the work of the government. The government has installed VSAT stations in the regions and in departments of Chad, which permit authorized licences to install VSAT stations in any corner of Chad to operate their independent networks.	Case study (satellite)
<a href="#">2/93</a>	18–Jul–11	OJSC Intellect–Telecom (Russian Federation)	Reducing energy costs through the implementation of a cellular telecommunication network with capacity transfer for rural and remote areas	This document provides some further information on the study presented in OJSC Intellect Telecom's earlier proposal in Document 2/002–E titled “Cellular telecommunication network with capacity transfer”, which would significantly reduce energy consumption.  The proposed technology for the deployment and operation of the associated (broadband) cellular telecommunication system will reduce capital costs (CAPEX) by a factor of 2–3, operational costs (OPEX) by a factor of 2–3 and energy consumption by a factor of 2–4, as well as using alternative energy sources.	New technology (broadband wireless)
<a href="#">2/94</a>	18–Jul–11	OJSC Intellect–Telecom (Russian Federation)	Reducing energy costs through the implementation of a "cellular telecommunication network with capacity transfer" for rural and remote areas	This document provides some further information on the study presented in OJSC Intellect Telecom's earlier proposal in Document 2/002–E titled “Cellular telecommunication network with capacity transfer”, which would significantly reduce energy consumption.  In contributions and materials for the meeting of the Rapporteur Group on Question 10–3/2 held on 22–23 March 2011 in Geneva, it was stated that solving the problem of telecommunication development in rural and remote areas will depend to a large extent on the implementation of technologies with reduced energy consumption. This document provides some additional information in this regard.	New technology (broadband wireless)

List of contributions submitted to Question 10–3/2 (for action)					
No.	Date	Source	Title	Abstract	Remarks
<a href="#">2/100</a>	10–Aug–11	Viet Nam	Strategic Action Plan for Telecommunication/ICT Development for Rural and Remote Areas	This contribution provides information regarding to Viet Nam's Strategic Plan on Information and Communications Development from now to 2020, with emphasis on relevant information regarding telecommunication and ICTs for rural and remote areas. Viet Nam hopes that this Strategic Plan can be useful to developing countries. Viet Nam looks forward to receiving comments from delegates and representatives from the membership.	National plan
<a href="#">2/101</a>	11–Aug–11	Rwanda Utilities Regulatory Agency (Rwanda)	Rwanda National Broadband within ICT Plans and Objectives for Success	This contribution gives the current status of efforts that Rwanda provides in building broadband. It mainly focuses on the fiber optic deployment and lightly on other broadband technologies.	Case study (optical fiber)
<a href="#">2/102</a>	18–Aug–11	People's Republic of China	EPON in the Rural Areas of China	This text describes the main characteristics of Ethernet Passive Optical Network (EPON) and its typical application in building rural broadband networks in China. Additionally, the text compares the project costs of FTTH and FTTV which are the two main ways to deploy EPON in rural China.	Case study (optical fiber)
<a href="#">2/105</a>	10–Aug–11	Mongolia	National Broadband Program of Mongolia	This contribution from Mongolia shares information about the National Broadband Program of Mongolia approved by the Cabinet of Government to achieve the goals of the Broadband Commission and ITU Declarations.  Globally, information and communication technology is developing rapidly and emerging technologies and services are extensively based on the broadband network and the internet. For Mongolia, the new technology and services entail a greater need for IP-based network infrastructure, along with the need for effective implementation, involving a steady demand for the development and implementation of a national program to create a favorable legal and regulatory environment and to identify required measures and action for the establishment, extension, use, possession and development of a broadband network. As a result of extensive surveying of Mongolia's current broadband network, along with international best practices, Recommendations from ITU and the Broadband Commission, global pacts and Conventions, as well as world trends regarding high-speed broadband networks and potential services deliverables through the network and the awareness of the importance of broadband use, a 5-year National Program (2011–2015) for nationwide implementation has developed and approved by the Cabinet of the Government of Mongolia on 03 May'2011, Resolution number 145.	National plan

List of contributions submitted to Question 10–3/2 (for action)					
No.	Date	Source	Title	Abstract	Remarks
<a href="#">RGQ10-3/2/14</a>	13–Jan–12	Argentine Republic	National Plan for the equipment of rural and border–area schools with satellite antennas	Through this planning we are seeking to bring digital terrestrial television to educational establishments in rural and semi–urban locations, as a tool for social inclusion and for bringing ICTs to those pupils most in need.	National plan (satellite)
<a href="#">RGQ10-3/2/16</a>	20–Jan–12	Malawi	Regulatory Challenges for Rural Telecommunications in Malawi	<p>This contribution presents constraints facing Malawi’s rural telecommunication growth and the regulatory challenges to universal access in the country.</p> <p>Malawi Communications Regulatory Authority (MACRA), established under section 3 of the Communications Act (1998) had been charged with the functions of ensuring that as far as it is practicable, reliable and affordable communication services sufficient are provided throughout the country to meet the demand. MACRA’s main function is to promote universal access to ICT services in Malawi.</p> <p>MACRA discharges its functions in such a way that it plans how the sector shall be developed in accordance with government policy for the sector. MACRA is mandated not only to plan how the sector shall be developed but also to monitor the growth of the sector. Like in most developing countries, observations have shown that it becomes very difficult to access Internet services in the rural and remote areas in Malawi. Though there has been some remarkable growth for mobile telephony, internet services are not available in most rural and remote areas of Malawi. This disadvantages the people living in the rural and remote areas. This disparity in access to ICT services is one of the challenges which the regulatory authority in Malawi is geared to address.</p>	Case study (universal access)

List of contributions submitted to Question 10–3/2 (for action)					
No.	Date	Source	Title	Abstract	Remarks
<a href="#">RGQ10-3/2/17</a>	08–Feb–12	Nepal (Federal Democratic Republic of)	Draft text for survey: “Developing a global compendium of policy and regulatory initiatives/ interventions for developing telecommu–nications/ICTs /broadband in rural and remote areas”	<p>Telecommunications/ICTs/Broadband has been considered sine qua non for the overall national development. Direct/indirect correlation has been established between meeting the MDGs targets and the availability, use and applications of Telecommunications/ICTs/Broadband. Most of the countries of the world have liberalized the telecom sector.</p> <p>However our experiences suffice to claim that without policy/regulatory interventions/ initia–tives, Telecommunications/ICTs/Broadband can be expanded in the rural and remote areas even in the developed countries. Many governments and regulators around the world have thus intervened with specific policy and regulatory measures so that the rural and remote areas of the country are also provided with Telecommunications/ICTs/Broadband services in a sustainable manner in a competitive prices and quality. This contribution has two parts.</p> <p>The second part of this contribution is an annex to the first part and is a questionnaire to collect information from the ITU member states/sector members to develop a global compendium of such policy and regulatory initiatives and interventions for developing Telecommunica–tions/ICTs/Broadband in rural and remote areas.</p> <p>Once such a compendium is developed, then this can be shared for benefit of the member states.</p>	National Plan, Questionnaire for survey
<a href="#">RGQ10-3/2/18</a>	14–Feb–12	Alcatel–Lucent (France)	Terrestrial wireless technologies for connecting rural communities	<p>It is well known that there is a ‘divide’ between those with access to broadband solutions and those, typically in more rural areas (but also in non–rural but under–served areas) who have limited or no access to broadband services. It is now considered that the current usage of video for key service applications requires a minimum of 1.5 mega bit per second downlink speed. Even so, recent advances in wireless broadband technologies and regulation provide a large range of solutions for deployment where wired solutions are too expensive or difficult to install, too slow to deploy or not well adapted to usage requirements. These trends in rural telecom deployment solutions are particularly important in developing countries as far as they address technical, social and economic targets.</p> <p>This contribution summarizes a large range of possible solutions deployable in licensed or unlicensed spectrum, either for access or for backhauling purposes, addressing fixed/nomadic as well as mobile connectivity in rural and under–served areas.</p>	New technology (broadband wireless)

List of contributions submitted to Question 10–3/2 (for action)					
No.	Date	Source	Title	Abstract	Remarks
<a href="#">RGQ10-3/2/19</a>	28–Feb–12	Rapporteurs for Questions 22–1/2 and 25/2	Report on developments at WRC–12 of possible interest to developing countries	<p>The World Radiocommunication Conference 2012 (WRC–12) was held in Geneva, Switzerland from 23 January – 17 February. At the request of Mr. Mokrane Akli, Chairman of Study Group 2, the Rapporteurs were asked to provide a brief summary of the conclusions of WRC–12 that might be of interest to developing country participants at the Rapporteur Group meetings in March 2012.</p> <p>The following represents the personal views of the Rapporteurs and not the views of any administration. Given the short time available to process the results of the WRC, this is only a high-level summary. Participants are encouraged to review the Provisional Final Acts now available on-line:  <a href="http://www.itu.int/md/R12-WRC12-R-0001/en">www.itu.int/md/R12-WRC12-R-0001/en</a>. Where possible, this contribution provides references to the Resolution numbers so the complete texts may be more easily located in the Provisional Acts.</p>	Report (WRC–12)
<a href="#">RGQ10-3/2/24</a>	15–Mar–12	Nippon Telegraph and Telephone Corporation (NTT), Japan	Proposal of high-speed/high-quality FWA system which achieves more economical broadband access network in rural areas	<p>In developing countries, it may take a long time before the optical access network is deployed. WIPAS (Wireless IP Access System) is an FWA system which provides high-speed broadband service to such countries quickly and economically. WIPAS has actually commercialized in some countries since 2003. It can be also applied to mobile backhaul (MBH) and several kinds of ICT applications.</p> <p>This contribution proposes that the WIPAS overview, its target applications and deployment examples, which are presented in this document, be considered to be used as materials for the future report on the Question 10–3/2 of ITU–D.</p>	New technology (broadband wireless)
<a href="#">RGQ10-3/2/25</a>	16–Mar–12	Japan	Case studies of rural telecommunications/ICT projects	<p>The Government of Japan has set forward various telecommunications and ICT projects for the development in rural and remote areas on bilateral and multilateral basis.</p> <p>This document tries to share some of the recent experiences of such projects. The examples shown in the document are:</p> <ol style="list-style-type: none"> <li>1. Pilot project for improved health &amp; medical environment with ICT for rural areas in Lao P.D.R,</li> <li>2. Broadband farm to market ecosystem for fisherfolk communities in Philippines, and</li> <li>3. ICT for human development and human security project in 12 countries in the South Pacific.</li> </ol>	Case study (e–health, e–agriculture, e–education)

List of contributions submitted to Question 10–3/2 (for action)					
No.	Date	Source	Title	Abstract	Remarks
<a href="#">2/158</a>	09– Jul–12	BDT Programme 1	Rural Broadband for Developing Countries: Options and Challenges	<p>This contribution provides an overview of a BDT report prepared on rural broadband with a focus on experience of India but equally relevant for developing countries in general.</p> <p>This report focuses on two forces opposing and neutralizing each other to bring broadband connectivity to a situation of stalemate. One is the technological option of developing suitable infrastructure that incorporates both the advantage of advanced technology and at the same time keeps the cost to the level of affordability of the target population in the remote and rural areas. The other is the realization that the cost of connectivity alone cannot ensure acceptance of broadband connectivity by the rural population. For the service provider as a business model it is finally the balance between the revenue and cost. The development perspective, however, has to go beyond the balance sheet and connectivity has to be connected with the development goals with tangible benefits.</p>	Report
<a href="#">2/160</a>	12– Jul–12	Argentina	Satellite Internet connectivity plan for rural schools in Argentina	This document informs participants of the plan to bring Internet connectivity to rural and border area schools in Argentina using satellite antennas.	National plan (satellite)
<a href="#">2/162</a>	24– Jul–12	Madagascar	Rural and remote areas	<p>Realization of the Millennium Development Goals aimed at improving connectivity and access to ICTs for everyone by 2015 requires the development of infrastructure in the rural and remote areas of developing countries, where over half of the world's population lives.</p> <p>This contribution (revision of contribution No. RGQ10–3/2/INF/5) presents some ideas concerning ICTs, economic and technological solutions for rural communities, the regulatory environment required and, globally, the manner in which ICTs can help to improve quality of life in rural and remote areas.</p>	Case study
<a href="#">2/167</a>	27– Jul–12	Madagascar	Widening access to mobile telephone services in Madagascar through the Cloud Phone system	Widening access to mobile telephone services in Madagascar through the Cloud Phone system.	Case study (universal access)

List of contributions submitted to Question 10–3/2 (for action)					
No.	Date	Source	Title	Abstract	Remarks
<a href="#">2/168</a>	03–Aug–12	OJSC Intellect–Telecom (Russian Federation)	Inexpensive, sustainable and energy–saving communication infrastructure for rural and remote areas based on the "mobile cellular network with capacity transfer"	This document explains the result of examination of "Mobile cellular network with capacity transfer." The use of the proposed technology reduces the capital and operating cost by two or three times and reduces electricity consumption by 2.5 to four times. In addition, the examination has highlighted that the capacity transfer repeaters are the key element of the network infrastructure in the mobile cellular network.	New technology (broadband wireless)
<a href="#">2/188</a>	29–Aug–12	Togo	Provision of basic services in rural telephony	The Millennium Development Goals aim to improve connectivity and access to ICT for all by 2015. To achieve these objectives, Togo has implemented several programs to ICT development. The program which is the subject of this contribution is the universal service. Since 2008, the definition of a new strategy of universal service has covered many places in rural areas in order to make available basic telecommunications services to the people of these communities.  This contribution aims to share the experiences of Togo in its program of development of ICT in remote rural areas and the difficulties he faced in the field.	Case study (universal access)
<a href="#">2/190</a>	31–Aug–12	Fujitsu Limited, Japan	Application of sensor network for agriculture	There is an increasing demand for ICT application for agriculture in Japan and in other countries. Fujitsu conducted sensor network trials for collecting field data such as temperature and humidity from the vineyards and sweet–corn fields and analyzed harvesting time or used for controlling air ventilation. This document introduces the overview of the trials and our findings and action items for future deployment.	Case study (e–agriculture)
<a href="#">2/198</a>	05–Sep–12	Russian Federation	Proposal of FWA system in 400 MHz for providing broadband wireless access in rural areas	The critical issue in many developing countries is huge gap between urban and rural areas in providing of broadband access services.  The Russian Federation has vast territory with difficult climate and long distances between the populated areas. For this reason much attention is paid to connecting rural and remote areas of Russian Federation.  In particular Russian Federation has long standing experience in using 400 MHz band for that purpose. The microwave point–to–point radio that uses this band provides low–cost and quick deployment of carrier networks for connection rural and remote areas with low density of populations where fiber or copper cabling is quite expensive or technically impossible. The equipment operates in UHF range and is able to transmit information over long distances up to 100 km. It could be modified to operate in any band in the 300–3000 MHz range.  This contribution includes microwave point–to–point fixed link overview, purpose of the system and	New technology (broadband wireless)

List of contributions submitted to Question 10–3/2 (for action)					
No.	Date	Source	Title	Abstract	Remarks
				networking examples. This material is proposed to be included into the Report on Question 10–3/2. Annex 1 contains information on FWA system according to Case Study Library Template. This information has been added to the case study library on Question 10–3/2 via ITU web site section for previous study period.	
<a href="#">2/219</a>	10–Sep–12	ITU Association of Japan, Japan	A plan of cost-effectively penetrating “real” broadband infrastructure into rural and remote areas in developing countries	This contribution proposes a plan to penetrate a “real” broadband infrastructure at relatively low cost in rural and remote areas in developing countries. The key is lightweight, thin, robust optical cables and their low-cost installation techniques that would open up a new door to penetrate ICT services into such areas thus effectively and quickly closing the digital divide. The plan was presented at TDAG and ASTAP both in 2012, and seventeen countries have so far expressed support in conducting the field trials in their countries. Practical comments and suggestions are invited particularly from developing countries.	New technology (fiber)
<a href="#">2/222</a>	10–Sep–12	Nepal (Federal Democratic Republic of)	Revised draft text for survey: “Developing a global compendium of policy and regulatory initiatives/ interventions for developing telecommunications/ ICTs/ broadband in rural and remote areas”	This document presents the revised draft questionnaire aimed to collect information to develop a compendium to be included in the outputs of the Question.	Questionnaire for survey
<a href="#">2/226</a>	11–Sep–12	Brazil (Federative Republic of)	New Brazilian General Plan for Universal Service – PGMU and 450 MHz	The Brazilian General Plan for Universalization brought great advance for fixed telephony in rural areas in Brazil. After its update, there are new goals for individual and collective access in rural areas with the use of 450MHz that need to be implemented country wide until December 2015.	National Plan (Universal Service)
<a href="#">2/228</a>	12–Sep–12	Tanzania (United Republic of)	Status of eHealth in the United Republic of Tanzania	This document reviews the status of current and on-going initiatives by the Government of Tanzania on e-health services. Having completed the implementation of national fiber optic backbone that connect all regions, during year 2011 and 2012, the Minister of Communications, Science and Technologies convened several meetings with stakeholders to deliberate e-health issues. He also formed a National Committee to oversee the implementation of e-health services which will start to ensure five hospitals are connected before the end of 2012. This paper provides brief overview on two major pilot projects which has been planned to take place this year and the way forward	Case study (e-health)



List of contributions submitted to Question 10–3/2 (for action)					
No.	Date	Source	Title	Abstract	Remarks
<a href="#">2/237</a>	18–Sep–12	General Secretariat	Broadband Commission presentation	The Broadband Commission for Digital Development was established by ITU and UNESCO in response to UN Secretary–General Ban Ki–Moon’s call to step up efforts to achieve the MDGs. Launched in May 2010, the Commission comprises government leaders from around the world and top–level representatives and leaders from relevant industries and international agencies and organizations concerned with development. The Broadband Commission embraces a range of different perspectives in a multi–stakeholder approach to promoting the roll–out of broadband, and provides a fresh approach to UN and business engagement. To date, the Commission has published a number of high–level policy reports, as well as a number of best practices and case studies to promote the roll–out of broadband networks and services in developing countries to help achieve the MDGs.	Report
<a href="#">RGQ10-3/2/27</a>	16–Oct–12	ITU–R Study Groups – Working Party 5D	Liaison Statement to ITU–R Working Parties 4B and 5C, ITU–T SG 13 Question 15/13 and ITU–D SG2 Questions 10–3/2 and 25/2, on the Appointment of Sub–Working Group Handbook Chairman and Work Progress	At its 14th meeting, Working Party 5D has appointed Dr. Bienvenu A. Soglo as chairman of Sub Working Group Handbook. WP 5D concurs with this initial organization and has considered placement of material and made modifications included at the appropriate location in the revised working document (Att. 3.13 to Document 5D/196). At this meeting, WP 5D also revised the work plan (Att. 3.14 to Document 5D/196) for the development of the handbook. Both working document and work plan are attached to this document. The meeting participants are invited to consider this document.	Report
<a href="#">RGQ10-3/2/28</a>	08–Jan–13	Rwanda (Republic of)	Access to telecommunication/ICT services by persons with disabilities and with special needs	According to the World Health Organization (WHO), it is estimated that 650 million people in the world live with some type of disability; 80% of the people live in low income countries such as East Africa member states and the number continues to grow creating survival challenges due to over dependence. As the world continues to witness the dynamism in the growth of ICT sector, it should be noted that greater social inclusion needs to be considered at all levels for sustainable ICT growth, economic development and reduction of dependence that results from excluding people/consumers with special needs and hence negating efforts put in development.  This contribution puts forward some policy and regulatory remedies in order to improve access to services by people with disabilities and gives also current status of projects which gives access to telecommunication/ICT services for persons with disabilities and with special needs in Rwanda.	Case Study (e–health)

List of contributions submitted to Question 10–3/2 (for action)					
No.	Date	Source	Title	Abstract	Remarks
<a href="#">RGQ10-3/2/31</a>	04–Feb–13	International Telecommunications Satellite Organization (ITSO)	Reference and resource for the Draft Report on Question 10–3/2	This document contains a Report from an ITU–ITSO workshop on “Satellites: A Solution for Broadband Access” that is relevant to the implementation of universal access to broadband services worldwide. The outcomes of this seminar may be useful to consider for the work towards a revised version of the Draft Report, particularly in elaborating sections of the report related to the role of satellite communications in broadband deployment plans and policies.	Report
<a href="#">RGQ10-3/2/32</a>	09–Feb–13	International Telecommunications Satellite Organization (ITSO) International Mobile Satellite Organization (IMSO) European Telecommunications Satellite Organization (EUTELSAT IGO)	Satellite Solutions for Digital Inclusion	Given their special characteristics, rapid deployment and ubiquitous coverage, satellite–based solutions have been increasingly utilized to help achieve universal broadband coverage, particularly for remote and rural areas where terrestrial infrastructure is limited, as well as providing coverage of the oceans, where other infrastructures are obviously unavailable. In light of the importance of the work of the UN Broadband Commission to the implementation of the Work Plan for Study Question 10–3/2, the co–authors invite the Rapporteur Group to consider the attached extracts from the Broadband Commission’s Report – State of Broadband 2012: Achieving Digital Inclusion for All when developing the Draft Report.	Report
<a href="#">RGQ10-3/2/34</a>	29–Jan–13	International Telecommunication Academy (Russian Federation)	ITU–D Study Group Question 10–3/2: Survey on Policy and Regulatory Initiatives for Developing Telecommunications/ ICTs/Broadband in Rural and Remote Areas	In response to the above survey on policy and regulatory initiatives for developing telecommunications/ ICTs/broadband in rural and remote areas, we propose an analysis of the situation in the Russian Federation and put forward a number of initiatives by the International Telecommunication Academy with a view to achieving improvements in this sector.	Report
<a href="#">RGQ10-3/2/35</a>	26–Feb–13	KDDI Corporation	Contribution to Case Study Library: Mobile WiMAX in Japan	This contribution is modified content of “Mobile WiMAX in Japan” for the new case study library.	Case Study (broadband wireless)

List of contributions submitted to Question 10–3/2 (for action)					
No.	Date	Source	Title	Abstract	Remarks
<a href="#">RGQ10-3/2/36</a>	03–Mar–13	Marshall Islands (Republic of)	Contribution to Case Study Library: Livelihood opportunities and culture preservation through a sustainable and eco-friendly ICT telecenter	This contribution is about a ICT development project in Mejit Island, one of the many under developed islands in the Marshall Islands. The Ministry of Transportation and Communications (MOTC) in cooperation with Mejit Local Government would create a COPRA COOPERATIVE or similar SUSTAINABILITY plan to stimulate the economic growth in the island, at the same time educating the community and the youths. Femto technology is the proposed solution for the outer island as an alternative to the expensive setup of GSM configuration which requires airconditioning unit and high cost of equipments.	Case Study (broadband wireless)
<a href="#">RGQ10-3/2/38</a>	05–Mar–13	SES WORLD SKIES (Netherlands)	Emergency.lu Rapid Response Communications Solution	Natural or man-made disasters and humanitarian emergencies often require rapid deployment of communications solutions to restore connectivity. Due to the volume of data required to coordinate a response, broadband connectivity is becoming increasingly essential to effective disaster response. Luxembourg companies have partnered with the Ministry of Foreign Affairs of Luxembourg to form emergency.lu, a satellite communication solution that can be installed within hours of a disaster. emergency.lu has been useful in supporting humanitarian missions in South Sudan and Venezuela, and in providing training exercises for emergency aid workers	Case Study (emergency communication, satellite)
<a href="#">RGQ10-3/2/44</a>	27–Mar–13	Qualcomm Incorporated (United States of America)	Contribution to Case Study Library: Mobile Health Information System: Providing access to information for health care workers	Through a collaboration of Qualcomm Wireless Reach, FHI 360, Eastern Cape Department of Health, MTN, Nelson Mandela Metropolitan University, and South Africa Partners, nurses and doctors in the East London Health Complex are using 3G wireless technologies to receive the latest health information and provide better care to their patients.	Case Study (e-health)
<a href="#">RGQ10-3/2/45</a>	27–Mar–13	Qualcomm Incorporated (United States of America)	Contribution to Case Study Library: Mobile Microfranchising & AppLab Project in Indonesia	In Indonesia, underserved residents, most of whom are women, are using mobile technology to access unique business opportunities and gain the skills needed to lift themselves out of poverty. Implementing partner Grameen Foundation, through its Mobile Microfranchising and Application Laboratory (AppLab) initiatives, is working with Qualcomm Wireless Reach and Ruma, a social enterprise that empowers the poor using mobile phone technology, to establish a multi-tier suite of data services that can be accessed via two distribution channels: (1) Ruma Entrepreneurs, a human network of mostly women who own and operate mobile microfranchise businesses, and (2) commercially available phones in the mass market.	Case Study (e-business)

List of contributions submitted to Question 10–3/2 (for action)					
No.	Date	Source	Title	Abstract	Remarks
<a href="#">2/267</a>	5– Jun– 13	ITU–R Study Groups – Working Party 5A	Liaison Statement from ITU–R WP5A to ITU–D SG 2 on the use of spectrum and radio technology low cost sustainable telecommunication infrastructure for rural communications in developing countries	This document contains an incoming liaison statement from ITU–R WP5A, concerning the use of spectrum and radio technology low cost sustainable telecommunication infrastructure for rural communications in developing countries. It is sent for information to the ITU–D/ITU–R Joint Group for Resolution 9 (Rev. Hyderabad, 2010) and ITU–D Study Group 2.	Statement
<a href="#">2/297</a>	9– Jul– 13	General Secretariat	UNGIS Joint Statement on the Post 2015 Development Agenda	In keeping with its mandate to promote policy coherence and programme coordination in the UN system, as well as provide guidance on issues related to information and communications technologies (ICTs) in support of internationally agreed development goals, the 30 members of the UN Group on the Information Society (UNGIS) will respectfully submit a joint statement to the UN Secretary General and the UN Task Team. The statement is a collective contribution to the dialogue on the Post–2015 Development Agenda, a unified effort to harness inter–agency expertise and experience to support deliberations on Post–2015 priorities, and a united commitment to a UN community poised to address development challenges in the 21st century. Reference: <a href="http://www.ungis.org/Portals/0/documents/JointInitiatives/UNGIS.Joint.Statement.pdf">www.ungis.org/Portals/0/documents/JointInitiatives/UNGIS.Joint.Statement.pdf</a>	Statement
<a href="#">2/306</a>	22– Jul– 13	ITU–R Study Groups – Working Party 5D	Liaison Statement from ITU–R WP5D to ITU–D Study Group 2 on the use of spectrum and radio technology low cost sustainable telecommunication infrastructure for rural communications in developing countries	(COPY TO ITU–D study group 2 and ITU–R WP 5a FOR INFORMATION) Working Party 5D endorses the liaison statement from Working Party 5A in <a href="#">Document 5D/331</a> in response to the liaison statement from ITU–T Study Group 5 in <a href="#">Document 5A/211</a> “Use of spectrum and radio technology low cost sustainable telecommunication infrastructure for rural communications in developing countries”. As also advised by ITU–R WP 5A, we agree that spectrum and radio technologies are clearly within the mandate of ITU–R and not ITU–T.	Statement

List of contributions submitted to Question 10–3/2 (for action)					
No.	Date	Source	Title	Abstract	Remarks
<a href="#">2/312</a>	29– Jul–13	Egypt (Arab Republic of)	Evaluating different access technology options	This contribution presents the summary of studies and consultations of “Evaluating Different Access technology options” performed by national telecommunications regulatory authority of Egypt in collaboration with vendors and some independent consultancy firms. The contribution consists of five major parts. The first part describes the purpose of such studies. The second parts identify the scope of the study. The third part demonstrates the assessment criteria. The fourth part includes the technology evaluation and analysis of the results and the last part highlights the key findings.	Report
<a href="#">2/322</a>	18– Aug–13	China (People’s Republic of)	WLAN Coverage solutions in rural China	The distribution of broadband users in rural China is dense at micro level while scattered from the macro perspective, and the wired network resource in remote villages is extreme inadequate. Contrary to the fixed broadband access network, WLAN with limited mobility, high bandwidth and low building cost, can be flexibly deployed and utilized, which means WLAN tends to better satisfy the broadband data access demand in rural areas. This contribution describes 3 kinds of WLAN Solutions in Rural China and transportation technologies for rural WLANs.	Case study
<a href="#">2/339</a>	6– Sep–13	Qualcomm Incorporated (United States of America)	Contribution to case study library: Fishing with 3G Nets (Environment and Entrepreneurs hips Project)	Qualcomm Wireless Reach™, Telefonica Vivo Foundation, the United States Agency for International Development, Editacuja Publishing and the Instituto Ambiental Brasil Sustentavel (IABS), a Brazilian environmental nonprofit organization, are collaborating on a project to promote sustainable social and economic development in fishing communities in the city of Santa Cruz Cabralia, in northeastern Brazil, through digital and social inclusion. Fishing is one of the main economic activities in the region and provides a living for families who have been in the business for years using techniques inherited from their ancestors. Over fishing, coupled with the lack of investment, has resulted in diminishing opportunities, reducing the income of the fishing communities and resulting in the emigration of young people to other cities in search of jobs. The project ‘Fishing with 3G Nets’ aims to support the implementation of new economic activities through the use of 3G connected smartphone and tablet applications.	Case study
<a href="#">2/340</a>	6– Sep–13	Qualcomm Incorporated (United States of America)	Contribution to case study library: Let’s Get Ready! Mobile Safety Project	Qualcomm Wireless Reach™ and Sesame Workshop, the nonprofit educational organization behind Sesame Street, are collaborating on a 3G mobile safety project to help families with young children in China learn about emergency preparedness. The “Let’s Get Ready!” project uses a 3G mobile website, mobile application and fun content featuring Sesame Street characters to create an interactive and engaging learning experience for children ages 3–6 and their caregivers. The project emphasizes the importance of knowing your name and address, having an emergency plan, packing an emergency kit, and learning about people and places within the community that can help in an emergency.	Case study

List of contributions submitted to Question 10–3/2 (for information)					
No.	Date	Source	Title	Abstract	Remarks
<a href="#">2/INF/3</a>	03– Sep– 10	Korea (Republic of)	The INV (Information Network Village) Project	<p>The INV project was created by the Ministry of Government Administration and Home Affairs (MOGAHA), now restructured and renamed as MOPAS (Ministry of Public Administrations and Security), in order to allow the public in remote areas to have easier access to content on, for instance, education, medical information, and agricultural skills to reduce the digital gap between geographical locations. It also enables direct supply of local products to consumers.</p> <p>The project plays an important role in boosting the local economy and in balancing regional development, which have been among the main objectives of the national agenda in Korea. At the beginning, the government took a cautious approach to avoid a potential waste of resources by using a step-by-step strategy. From August 2001 to May 2002, the first phase of the project had been carried out involving 25 villages which are mainly located in agricultural and fishing areas. Since it was launched, the project has gone through 8 phases until the end of 2009, with each phase taking a year.</p>	Case study (broadband access)
<a href="#">2/INF/4</a>	06– Sep– 10	TURK TELEKOMU NIKASYON A.S.	Turkey's rural transforma- tion project	By the increasing importance of ICT regarding the development of economies, especially in developing countries, telecommunication investment for rural and remote areas should be considered as a strategic vehicle to overcome the social, cultural and economic bottlenecks towards an integrated economy. In this context, Turk Telekomunikasyon Group has taken this issue on its agenda since 2007 and invested heavily over a wide range of Turkey with the inferior conditions and limited access to common welfare. In the scope of this project, fixed division of Turk Telekom Group achieved the rural transformation of the telecom infrastructure successfully in a shorter time period and made it ready for Next Generation Network.	Case study (NGN)
<a href="#">2/INF/7</a>	07– Sep– 10	Republic of Korea	Korean Case Study of Inducing Middle-aged People to Use Internet	There are two types of internet population growth model: equilibrium and disequilibrium. Disequilibrium may cause digital divide. Generally young people are very good at new trend but old people are not. So the main issue is how to induce the old group to join the internet population. Here is one effort, as an equilibrium model, from the Korean government for bridging digital divide between generations. The Korean government task force group studied the profile and requirement of the lagging group and found killer application for them, along with learning opportunities on PC operation. And the private sector developed service applications needed.	Case study

List of contributions submitted to Question 10–3/2 (for information)					
No.	Date	Source	Title	Abstract	Remarks
<a href="#">2/INF/16</a>	06–Jun–11	ITU–T Study Group 5	Response on the request for information regarding up–to–date power supply solutions for telecommunications/ICT infrastructure for rural and remote areas	ITU–T Study Group 5, Question 22/5 will share the requested information with ITU–D Study Group 2 Question 10, 22 and 25 once this material becomes available.	Report
<a href="#">2/INF/21</a>	20–Jul–11	Cameroun	The new legislative and regulatory environment for electronic communications	This document is submitted for information, gives some developments of the reform of telecommunications and ICT business in Cameroon there are more than 10 years.	Case study (ICT policy)
<a href="#">2/INF/25</a>	08–Aug–11	Republic of the Marshall Islands	Livelihood Opportunities and Culture Preservation through a Sustainable and Eco–Friendly ICT Telecenter	<p>Mejit Island is one of the many under developed islands in the Marshall Islands that has 80 households (300–400 inhabitants), more or less, living on a 0.72 square miles of land mass, and roughly 1 mile stretch from end to end of the inhabited area. The inhabitants have a little means of livelihood, or even none. Most of them only rely on their daily sustenance from crops and riches of the ocean. Mejit is known for their special kind of weaving pattern. Leaf–weaving is one of the cultures that the Marshallese need to carry on to the next generation. With the deployment of ICT in the island, this will attract tourist and prospected international investors to the leaf weaving and rope making with the proper information campaign. The rope making culture is dying right now and the government leaders must act to preserve the culture through the use of ICT, and e–learning. Mejit is one of the islands that is deprived of computer access due to economical circumstances, this depriving them from education.</p> <p>As for communication, the only means is through HF radio. This has been there for more or less two (2) decades now. The Ministry of Transportation and Communications (MOTC) in cooperation with Mejit Local Government would create a COPRA Cooperative or similar Sustainability Plan to stimulate the economic growth in the island, at the same time educating the community and the youths. Educating the public thru ICT also includes the preservation of the natural habitat and this is the same reason we will harness the power of the sun and wind. Internet access can be done by</p>	Case study (broadband access)

List of contributions submitted to Question 10–3/2 (for information)					
No.	Date	Source	Title	Abstract	Remarks
				“internet access scratch card” for those who have their own computers with wireless access since WIFI will be deployed to cater to business, individuals, and tourists. With the deployment of both hardware and software mechanism, this will minimize the need for telecenter accountants or cashiers. MOTC will have an ICT awareness training program for the teachers that would be dispatched to the Mej.	
<a href="#">2/INF/26</a>	09–Aug–11	Korea Communications Commission (KCC) (Republic of Korea)	Broadband Internet in Rural and Remote Areas of Korea	Rural broadband has been completed in Korea through the cooperation of private telecoms operator (KT, former state-owned operator) and the Government (central and local) by 2008 and currently Next Generation Network is under construction in the rural areas. KT’s cooperation was ensured by the ‘Decree of Universal Service Obligation of KT’ which has been prepared to impose KT to fulfill the duty of rural broadband internet connectivity even after the privatization of KT. However, broadband construction in the far remote areas such as the village of less than 50 households could be a financial burden for KT and therefore, the Korean Government has decided to provide financial subsidies for the construction of broadband networks for deep remote areas. The financial subsidy has amounted to 50% of the total construction cost and it was shared by central and local Government by half and half. This policy has enabled households in rural areas to subscribe broadband internet at the same price with same quality as urban households. KT has been cooperative on this project since KT, as a nation-wide operator, can compensate the profit loss in the areas where a few household subscribes broadband with the profit gained in other areas where sufficient subscribers are secured.	Case study (broadband access)
<a href="#">2/INF/34</a>	9–Aug–11	Congo (Democratic Republic of)	ICT communications in remote rural areas	The problem of telecommunications in the DRC still arises due to lack of adequate infrastructure that allows for a harmonious development. Though the installation of the long-awaited fiber optic cable has been completed, operation drags for reasons unknown.	
<a href="#">2/INF/36</a>	15–Aug–11	Bangladesh Telecommunication Regulatory Commission (Bangladesh)	Statistics and Strategic Action Plan of Telecommunication/ICT Development in Bangladesh: Rural and Remote Areas	This contribution provides information on Bangladesh’s status with respect to access to technology for broadband telecommunications including IMT. It also covers relevant information regarding telecommunication and ICTs for rural and remote areas of Bangladesh.	Case study (broadband access)



List of contributions submitted to Question 10–3/2 (for information)					
No.	Date	Source	Title	Abstract	Remarks
<a href="#">2/INF/38</a>	05–Aug–11	Pakistan	Telecom/ICTs for Rural and Remote Areas – Universal Service Experience of Pakistan	The document is presented to share the experience of Ministry of Information Technology and other stakeholders in the successful roll out of telecommunications/ICT services in rural and remote areas of Pakistan through the Universal Service Policy framework and corporate structure (Public – Private Partnership). The document also enlists the challenges faced by Ministry of Information Technology and stakeholders in the actual implementation of the programme. Member states may be encouraged to share their experience in this regard.	Case study (universal access)
<a href="#">2/INF/41</a>	10–Aug–11	Uganda	Uganda’s Approach to Implementing Broadband Connectivity in Underserved Areas	This document presents Uganda’s Approach to Implementing Broadband Connectivity in Underserved Areas and Uganda’s Universal Access Policy (2010) (available at: <a href="http://www.ucc.co.ug/rcdf/rcdf-Policy.pdf">www.ucc.co.ug/rcdf/rcdf-Policy.pdf</a> ). Internet penetration, access and usage in Uganda is still very low. This is also largely confined to urban commercial centers. Although Uganda’s previous universal access policy had supported the installation of Internet points of presence in all the underserved districts, the internet bandwidth speeds and quality of service issues has been of major concern by the end users. Therefore the new policy objective is expected improve broadband uptake in selected underserved areas as a pilot case. The pilot project will offer experiences for developing a national broadband policy and strategies for its implementation.	Case study (broadband access)
<a href="#">2/INF/55</a>	09–Sep–11	Japan	Overview of Fixed and Mobile Broadband environment in Japan	Japan would like to inform the meeting about the situation of Fixed and Mobile Broadband services, especially LTE services delivered by NTT DoCoMo.	Case study (broadband wireless)
<a href="#">2/INF/74</a>	14–Sep–11	Telecommunication Standardization Bureau	Future Networks by ITU-T	The attached presentation provides an overview of the work of ITU-T Study Group 13 and the dedicated Focus Group on Future Networks.	Report
<a href="#">2/INF/76</a>	14–Sep–11	Türk Telekom Group, Turkey	Fiber Effect	The attached presentation provides an overview of the correlation between fibre, broadband penetration and incomes and how fibre can accelerate the growth of the broadband incomes.	Case study (optical fiber)

List of contributions submitted to Question 10–3/2 (for information)					
No.	Date	Source	Title	Abstract	Remarks
<a href="#">RGQ 10-3/2/INF/4</a>	22–Dec–11	The Abdus Salam International Centre for Theoretical Physics	ICTP’s Fifteen Years Experience in ICT Training and Dissemination	The Abdus Salam International Centre for Theoretical Physics (ICTP) in Trieste, Italy, has been active in knowledge dissemination, focusing on training of young scientists that could diffuse the acquired knowledge further in their native regions. ICTP has been playing a leading role in the field of training in ICT for developing countries. In the last fifteen years, more than 40 training activities on wireless networking have been organized both in house as in-situ. Several projects have been developed starting from training activities, and the knowledge acquired has been widely disseminated.	Case study (training)
<a href="#">RGQ 10-3/2/INF/5</a>	30–Jan–12	Madagascar (Republic of)	Contribution of Telecommunications / ICT to improve the quality of life in rural and remote areas	To achieve the Millennium Development Goals aimed at improving connectivity and access to ICT for all by 2015, it is essential to develop infrastructure in rural and remote areas of developing countries, where there is more than half of the world population. This paper presents some ideas on ICT technology solutions for rural economic and regulatory environment necessary and generally how ICT can improve the quality of life in rural and remote areas.	Case study (universal access)
<a href="#">2/INF/79</a>	16–Jul–12	BDT Programme 1	Status Report on the Implementation of ITU Conformance and Interoperability (C&I) Programme	<p>PP–10 Resolution 177 endorsed the objectives of WTSA–08 Resolution 76 and WTDC–10 Resolution 47 as well as the recommendations of the Director of TSB endorsed by Council–09, and asked “that this programme of work be implemented in parallel without any delay.”</p> <p>In January 2012 the Assembly of the Radiocommunication sector of ITU approved the Resolution 62 titled “Studies related to testing for conformance with ITU R Recommendations and interoperability of radiocommunication equipment and systems on conformity and interoperability” so that all the sectors, now, have a resolution on this topic.</p> <p>A Business Plan on C&amp;I, based on four pillars, has been developed by KPMG, a consultancy with excellent credentials in business plan preparation and the results of the studies will be presented to the next ITU Council. Within the ITU Secretariat, a C&amp;I Task Force has been set up with participation of representative of all ITU Bureaux to mobilize resources internally and co-ordinate the implementation of the four pillars.</p> <p>This document summarizes the status of implementation of the respective Resolutions.</p>	Report

List of contributions submitted to Question 10–3/2 (for information)					
No.	Date	Source	Title	Abstract	Remarks
<a href="#">2/INF/082</a>	07–Sep–12	Japan	Country case study: Pilot project for the improved health & medical environment with ICT for rural areas in Lao P.D.R.	This document tries to share the information of the ICT project, “Pilot project for improved health & medical environment with ICT for rural areas in Lao P.D.R”, which was introduced in the Document RGQ10–3/2/25–E, in the format provided in the Document 2/195–E.	Case study (e–health)
<a href="#">RGQ 10-3/2/INF/07</a>	25–Mar–13	OJSC Intellect–Telecom (Russian Federation)	Energy effective and low cost technology for wireless broadband access and GSM cellular networks	This document presents the next step of development of the “Energy effective and low cost technology for wireless broadband access and GSM cellular networks”, for real 450 km motor road in Nizhny Novgorod region and the Northern part of the town of Gornoaltaysk in Russia. Energy saving effect of these projects is no less than 2–3 times, confirming the indexes shown in documents C–094, C–0168.	New technology (broadband wireless)
<a href="#">2/INF/83</a>	19–Jul–13	Bhutan (Kingdom of)	Case Study: WiMAX and FiberWiFi Broadband in Rural Areas of Bhutan	This document is related to the Broadband Pilot Project Report. Pilot project clients in all four geogs (villages) prior to the pilot project were using 3G data card or subscribed to mobile internet to access Internet. People in these geogs had to travel more than half a day to access Internet. Given the lack of IT literacy and technical know–how in the geogs, for the project connectivity until the customer premises is managed by Tashi InfoComm Limited (TICL). To ensure project sustainability, TICL will manage the business aspect of project without any intervention from department. Broadband through WiMAX provided easy and fast deployment in the geogs, than fiber optic cable.	Case Study
<a href="#">2/INF/84</a>	1–Aug–13	India (Republic of)	Innovative technological solution for broadband use in rural areas – Data Rural Application Exchange (D–Rax from C–DoT)	The contribution is a case about an innovative project in making broadband services accessible to rural masses with low literacy and ICT skillsets challenges. The objective of this contribution is a case study of a product from CDoT1 that exclusively developed to take care of limitation of ICT skillsets in rural people. The product is significant as it deals with one of the fundamental issues i.e. lack of ICT skillsets and literacy rampant for large masses to benefit from the broadband services to exploit the opportunities for their socio economic development.	Case Study

List of contributions submitted to Question 10–3/2 (for information)					
No.	Date	Source	Title	Abstract	Remarks
<a href="#">2/INF/85</a>	1–Aug–13	India (Republic of)	A concept paper on setting up of Tele-education Network in developing countries	The contribution is a case on implementation of Tele-education project through Pan – African E–Network Project by M/s Telecom Consultants of India Limited, a Government of India Enterprise. The project has been very successful and won several awards for innovation. This model could be used as an example for providing educational services through ICTs in the developing countries.	Case Study
<a href="#">2/INF/86</a>	1–Aug–13	India (Republic of)	Successful e–initiative for rural people in remote North Eastern part of India – Active community participation for sustainability	The contribution briefly analyzes key factors of two successful e–initiative of ICT projects for rural poor in North Eastern part of India, with a view to frame a sustainable strategy for ICT deployment in the backward regions. The community participation (mainly of rural tribal women) for framing policies and their active involvement throughout implementation of ICT projects had become mandatory for any sustainable development in the remote tribal areas.	Case Study
<a href="#">2/INF/88</a>	9–Aug–13	Japan	Country Case Study: Telecommunications/ICT development by ad–hoc communications network for rural Shiojiri City in Nagano prefecture (Japan)	This document shares information on the ICT project, “Telecommunications/ICT development by ad–hoc communications network for rural Shiojiri City in Nagano prefecture, Japan”, which was introduced during the April 2013 meeting (Document RGQ10–3/2/48–E) and using the new case study format provided in the Document 2/195.	Case Study
<a href="#">2/INF/92</a>	20–Aug–13	Côte d’Ivoire (République de)	Evolution of the regulatory and institutional framework in the field of Telecommunications / ICT in Côte d’Ivoire	This paper has the following two main objectives: i. Briefly present the evolution of the regulatory reform and institutional framework of Telecommunications / ICT in Côte d’Ivoire; ii. Allow an update of information on the experience of Côte d’Ivoire, in the reports for the issues discussed in the committees Studies 1 & 2 of the ITU–D.	Case Study

List of contributions submitted to Question 10–3/2 (for information)					
No.	Date	Source	Title	Abstract	Remarks
<a href="#">2/INF/93</a>	16–Sep–13	Telecom–munication Development Bureau	Case Study submitted to the Case Study Library: Satellite broadband supporting elections in Burkina Faso	This document contains a case study that was submitted by SES World Skies (Netherlands) to the Case Study Library on “Satellite broadband supporting elections in Burkina Faso”. In December 2012, SES Broadband Services provided satellite broadband services for the parliamentary and municipal elections in Burkina Faso. As part of the agreement with the Independent National Elections Committee (CENI) in Burkina Faso, SES Broadband Services and its partners Newtec, Access Sat and Unicom provided satellite equipment and bandwidth to enable connectivity between the 45 electoral district offices, which serve as the hubs for 14,698 polling stations across the country, and the central election office in the capital, Ouagadougou. The system was used for video conferencing, video surveillance, Internet access, and fast and secure communication of ballots.	Case Study

## Annex 2: Analysis of questionnaire replies for global survey on policy initiatives/interventions on telecommunications/ICTs/broadband development

### 1 Survey background

The overall aim of ITU–D Study Group 2 Question 10–3/2 is to study “the range and scope of techniques and solutions that are expected to play a significant role in the provision of e–application services for rural and remote areas.” In order for the Question to successfully complete its work for the 2010–2014 further input is needed from the ITU membership on techniques that can be used to best deliver the range of services, and applications required by rural and remote communities and adapted to the needs of their users.

### 2 Survey objectives

The purpose of this survey is to gather detailed information on policy and regulatory measures that have been taken by the governments around the world and economic and business models for telecommunication/ICT growth in rural and remote areas. The survey also seeks to collect information on possible impact and analysis of such interventions/initiatives.

The input received through this survey will be used as part of the outputs of the Question for the 2010–2014 study period, intended to assist countries in strengthening their capacity to address challenges for the development of telecommunications/ICTs/broadband in rural and remote areas.

### 3 Survey range

The Questionnaire was sent to Administrations of ITU Member States and Observer (Res. 99), ITU–D Sector Members, Associates and Academia, Management Teams for ITU–D Study Groups 1 and 2, and Observers (Regional and International Organizations).

Total of 29 entries from 27 countries were received.

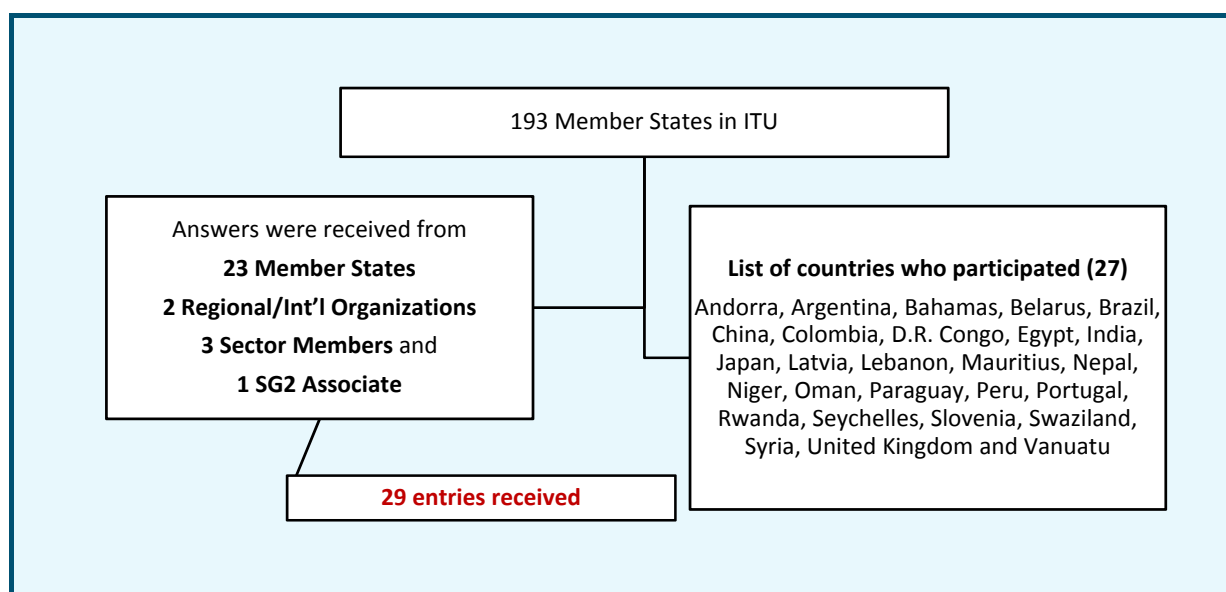

Among 29 entries received, entries received from Sector Members and Regional/Int'l Organizations are; Cellular Operators Association of India, United Kingdom Telecommunications Academy (International), AHCIET, ABI Research (United States), The Egyptian Company for Mobile Services and Cable Bahamas Limited

## 4 Survey Questions

The questions asked in the survey were as below;

### CONTACT INFORMATION

- a. Contact details
- b. Please select the name of your Administration/Organization from the list.  
*(If it is not available, indicate the name in the field below the list)*
- c. Region where your organization is based:
  - Africa
  - The Americas
  - Asia and Pacific
  - Arab States
  - CIS countries
  - Europe
- d. Country/countries where your organization is based

### SURVEY

- 1 Is there a formal definition of 'rural' or 'remote' areas?
  - Yes
  - No
- 1A If yes, please provide the definition(s).
- 1B If no, how do you handle policy related issues pertaining to telecommunications/ICTs /Broadband in rural and remote areas? (Please specify the present situation and eventual future policies)
- 2 Is there any specific government policy on Telecommunications/ICTs/Broadband development in rural and remote areas?
  - Yes
  - No
- 3 If a government policy does exist, please specify which one:
  - Telecommunications in rural and remote areas
  - ICTs in rural and remote areas
  - Broadband in rural and remote areas
  - Other
- 4 What are the major features of such a policy? (Please make 2 or 3 proposals of these features)
- 5 If no specific government policy on Telecommunications/ICTs/Broadband exists, how are the issues of Telecommunications/ICTs/Broadband in rural and remote areas being handled?

- 6 Is this a part of the national telecommunication/ICTs/broadband policy?  
Yes  
No
- 7 If it is part of the national telecommunication /ICT/Broadband policy, what provisions are made in the broad policy framework?
- 8 If it is not part of the national telecommunication /ICT/Broadband policy, is there any project in the future for it to be come part of it?  
Yes  
No  
*Please specify in either case: \_\_\_\_\_*
- 9 Is the Telecommunications/ICTs/Broadband in rural and remote areas considered a universal service/access obligation?  
Yes  
No
- 10 If it is, how is that obligation defined?
- 11 Is there a provision of Universal Service Fund or similar type of fund for the development of Telecommunications/ICTs/Broadband in rural and remote areas?  
Yes  
No
- 12 If such a provision exists, how are the funds collected?  
As a % of annual Gross Revenue  
As a fixed amount every year from the operators providing telecom services, etc.  
As committed by the service provider during licensing process  
Other scheme  
*If "Other scheme" was selected, please specify: \_\_\_\_\_*
- 13 Who is responsible for disbursement in question 12?  
The government ministry  
The telecom regulator  
A separate body established for this purpose  
Other provision  
*If "Other provision" was selected, please specify: \_\_\_\_\_*
- 14 Who is responsible for managing those funds?  
The government ministry  
The telecom regulator  
A separate body established for this purpose  
Other provision  
*If "Other provision" was selected, please specify: \_\_\_\_\_*
- 15 What kind of economic model is being employed for the development of Telecommunications/ICTs/Broadband in rural and remote areas?  
Free market  
Capital subsidy provided for existing operator  
Capital and ongoing subsidy for existing operator  
Other  
*If "Other" was selected, please specify: \_\_\_\_\_*



- 16 What kind of business model is being developed?  
Government owned incumbent operator mandated to provide the service  
Public–Private Partnership model (Private operators with capital subsidy)  
Private Operators with no subsidy but with other regulatory incentives  
Multi–stakeholders partnership model  
Other model  
*If “Other model” was selected, please specify: \_\_\_\_\_*
- 17 How is major backbone infrastructure being developed in rural and remote areas? There is a National Broadband Network funded by:  
Government’s special budget  
Through the USO fund  
Any other sources such as donor agencies’ assistance  
Other source for funding  
Operators are building their own backbone network in isolation  
Operators are sharing their backbone networks  
Other scheme  
*If “Other source for funding” was selected, please elaborate: \_\_\_\_\_*  
*If “Other scheme” was selected, please specify: \_\_\_\_\_*
- 18 Do you have any specific policy, legal and/or regulatory framework for infrastructure sharing, especially in the rural and remote areas, for example optical fiber cable and BTS/Microwave towers and the related support infrastructures?  
Yes  
No
- 19 If such a framework exists, who issues such instruments?  
Government  
Regulator  
Other competent authority  
*If “Other competent authority” was selected, please specify: \_\_\_\_\_*
- 20 Are there any instances of infrastructure sharing even in the absence of such instruments mentioned in Question 9–3/2?  
Yes  
No  
*If yes, please elaborate: \_\_\_\_\_*
- 21 Are you planning to bring such guidelines to address the rural challenges?  
Yes  
No
- 22 Does your government provide any kind of tax rebate for import of equipments for providing Telecommunications/ICTs/Broadband in rural and remote areas?  
Yes  
No
- 23 Do the license conditions oblige the Operator/Service provider to provide service in rural and remote areas?  
Yes  
No

- 24 Do you provide a specific rural/remote area license to Telecommunications/ ICTs/Broadband providers in rural and remote areas?  
Yes  
No
- 25 If you answered yes to question 24, are these providers allowed to provide services in urban areas once rural and remote obligations are met?  
Yes  
No
- 26 What backhaul/backbone technologies are being used in your country for connecting rural and remote areas ? Please tick all that applies  
Satellite/V-SAT  
Optical Fiber  
Cable  
Terrestrial Microwave  
Wireless such as WiFi, WiMax, LTE, etc  
Other technology  
If "Other technology" was selected, please specify: \_\_\_\_\_
- 27 What access technologies are being used in your country for connecting rural and remote areas ? Please tick all that applies  
Copper  
Cable  
Fibre  
Fixed Wireless Access  
Mobile such as GSM,CDMA, etc.  
Broadband such as 3G, WiMax, 4G, etc.  
Other technology  
If "Other technology" was selected, please specify: \_\_\_\_\_
- 28 If there is any other specific policy/regulatory intervention/initiatives by your government or regulator—please elaborate.

## 5 Survey Results

### 0 Region where your organization is based:

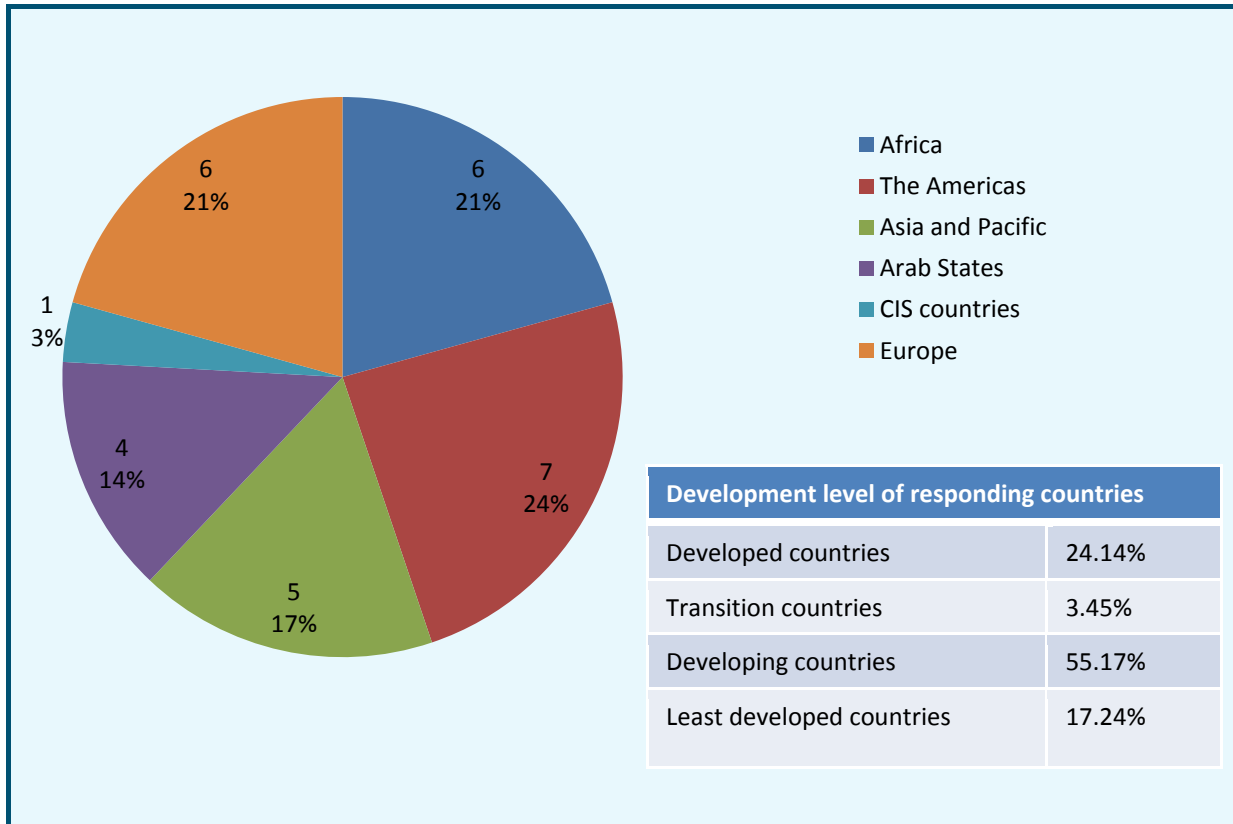

### 1 Is there a formal definition of 'rural' or 'remote' areas?

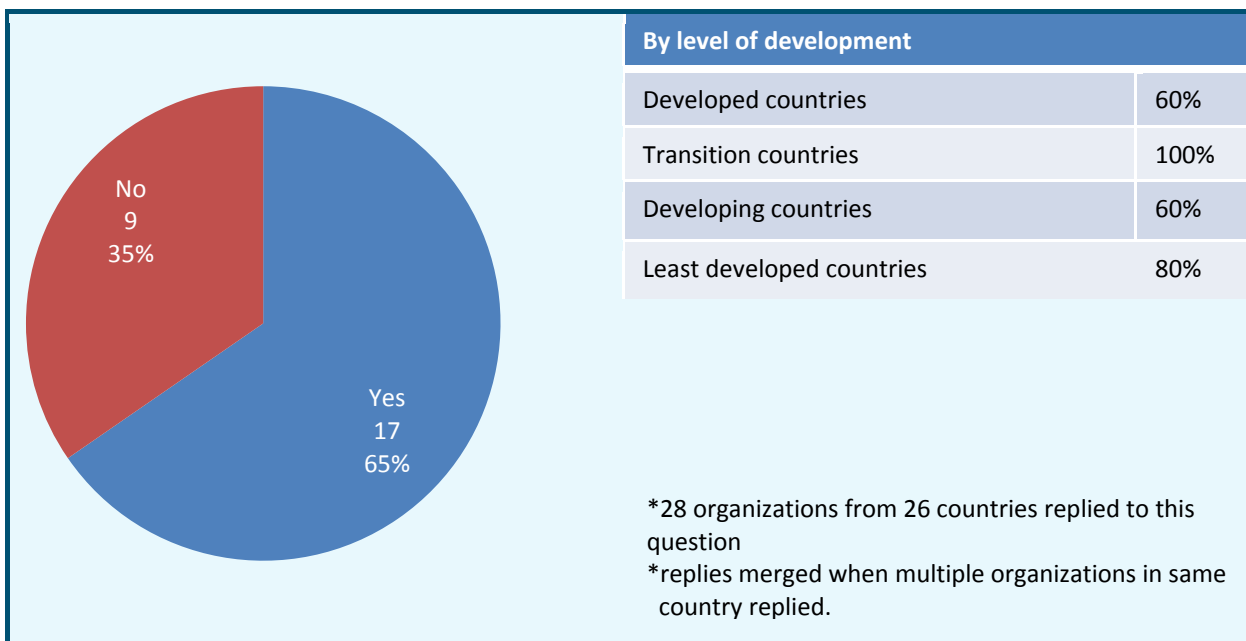

**1.a If yes, please provide the definition**

United Kingdom Telecommunications Academy (UKTA) (International)	UKTA is committed to providing eEducation on Policy & Regulation to the Least Developed Countries of the World.
ABI Research (United States)	<p>The Rural Definition was introduced in 2004 as a joint project between the Commission for Rural Communities (CRC – formerly the Countryside Agency), the Department for Environment, Food and Rural Affairs (Defra), the Office for National Statistics (ONS), the Office of the Deputy Prime Minister (ODPM) and the Welsh Assembly. It was delivered by the Rural Evidence Research Centre at Birkbeck College (RERC).</p> <p>Areas forming settlements with populations of over 10,000 are urban, as defined by ONS urban area boundaries based upon land use. The remainder are defined as rural town and fringe, village or hamlet and dispersed using detailed postcode data. These (rural) settlement types are defined using population density at different scales. Once identified these are used to characterize census units (such as Output Areas and wards). Rural town and fringe areas tend to be relatively densely populated over an extended area, whereas village and hamlet areas generally have lower population densities and smaller settled areas.</p>
The Egyptian Company for Mobile Services (MOBILNIL)	Towns or villages that have a population of less than 2500 inhabitants.
Ministerio de Tecnologías de la Información y las Comunicaciones (Colombia)	The national statistics authority defines a rural zone as that where dwellings and land or fishing farms are dispersed and where, generally speaking, public services are not available. Human settlements in rural areas are defined as concentrations counting at least 20 adjacent houses.
Telecommunication & Radiocommunication Regulator (TRR) (Vanuatu)	Telecommunications service for locations which are not or not adequately served by existing services
Ministère de la Communication et des Nouvelles Technologies (Niger)	Sparsely-populated areas with little or no basic social infrastructure (telephony, electricity, schools, dispensaries, etc.) and deemed unprofitable in terms of the heavy investment required for the deployment of a telecommunication/ICT infrastructure owing to the low revenues of rural populations.
Syrian Telecommunication Regulatory Authority (SyTRA) (Syrian Arab Republic)	Rural or remote areas are areas or villages that are relatively distant from towns; the population of these areas does not exceed 2 000.
Nepal Telecommunications Authority (NTA) (Nepal (Republic of))	Rural Areas: Those Village Development Committees (VDCs) excluding Kathmandu Valley, Metropolitan Cities, Sub-Metropolitan Cities, Municipalities and its adjoining VDCs are referred to as Rural Areas.
CATR of Ministry of Industry and Information Technology (MIIT) (China)	<p>Rural areas are divided into incorporated (administrative) villages and unincorporated (natural) villages.</p> <p>An incorporated village refers to the very basic rural administrative unit established by the government under the township level for the sake of organization. It is comprised of several natural villages. In terms of the relationship between these two terms, a natural village is under an incorporated village, i.e. several small neighbouring villages may form a bigger incorporated village. This incorporated village is administrated by a leading group (party branch and villagers' committee), while different administrative groups (villagers' groups) are established in its subordinate natural villages, with a leader appointed for each group. Unincorporated villages are administrated and led by the villagers' committee of the corresponding incorporated village and the party branch of the village.</p>

AHCIET (Colombia)	Rural areas are understood to mean those with population centres of fewer than 2 500 inhabitants and as a rule dispersed, with little in the way of mobile or fixed infrastructures. They are normally classified as universal service objectives, and state investment is crucial because of the limited economic interest for operators, given that the cost of providing some services is too great for a company acting on its own and potential profits are low. Public intervention is crucial for achieving digital inclusion of these areas, and the State must develop the best ways of channelling the necessary investment.
Organismo Supervisor de Inversión Privada en Telecomunicaciones (Peru)	Population centres meeting the following criteria are defined as rural areas: <ol style="list-style-type: none"> <li>1 They do not form part of urban areas as defined by the Instituto Nacional de Estadística e Informática (INEI). According to INEI, the concept of urban area refers to that part of the territory of a district that is made up of urban population centres; that part may be made up of one or more urban population centres, a population centre being a location comprising a minimum of 100 residences grouped together forming blocks and streets. In addition, all district capitals are considered to be urban population centres even if they do not meet this criterion. An urban population centre is generally made up of one or more urban concentrations.</li> <li>2 They have a population of less than 3 000 inhabitants, according to the latest population census or official forecast.</li> <li>3 They have scarce basic services.</li> </ol> Those localities with a teledensity of less than 2 fixed lines per 100 inhabitants are also considered to be rural areas without necessarily having to meet the above criteria.
Ministry of Communications and Informatization (Belarus)	The category “rural centres of population” comprises: <ul style="list-style-type: none"> <li>– Agro–townships: well–equipped centres provided with production and social infrastructure to ensure that minimum state standards of social amenities are met for the inhabitants of these centres and of the surrounding areas.</li> <li>– Settlements, villages: centres of population provided with production and social infrastructure and not classified as agro–settlements.</li> <li>– Farmsteads: populated centres not classified as agro–townships, villages or settlements.</li> </ul>
Agência Nacional de Telecomunicações – ANATEL (Brazil)	There are several definitions for rural and remote areas depending on applicable laws, sector and jurisdiction. In Brazil, the Federal Law 5.172/1966 defines that urban area must have at least two of the following items: curb or sidewalk, with piped water; water supply; sewer system; public lightning; primary school or healthcare institution less than 3 kilometres from the reference building. Therefore, rural and remote areas are any area that don't fit those requirements. Furthermore, each and every city may further this definition, as long as it doesn't contradict the Federal Law. The Telecommunications Agency defines rural areas in Decret 7.512/2011 as every region outside the Basic Tax Areas (set of continuous Cities in the same State).
Ministry of Transport of the Republic of Latvia (Latvia)	A rural area is a geographic area that is located outside the cities and towns.
Office of the President, Department of Information Communication Technology (Seychelles)	The outer islands in Seychelles are considered as remote areas. There are 72 outer islands.
Oman Telecommunications Regulatory Authority (TRA) (Oman)	The rural areas are the areas outside the main cities with a population from 200–2000 inhabitants, but the remote areas are the areas with a population below 200 inhabitants.
Rwanda Utilities Regulatory Authority (RURA) (Rwanda)	Area out of delimited boundaries of towns and cities.

<p>ICP – Autoridade Nacional de Comunicações (ANACOM) (Portugal)</p>	<p>In terms of policy for the development of high-speed networks/NGAs (in rural areas), these are defined as parts of the national territory, mainly rural, where it is unlikely that, in the near future, the market will generate the incentives necessary for operators to invest in new infrastructure for the provision of broadband access services (especially high-speed), e.g. due to factors critical to the investment, such as population density (which determines the cost of bringing the network to households) and socio-economic factors such as age, education level and per capita income (which determine the potential revenue generated by the network). It is noted that in each of these areas, the municipalities covered are those with no competition at retail level, particularly those without cable network coverage and coverage by (co-located) alternative operators.</p>
<p>Comisión Nacional de Comunicaciones (CNC) (Argentina)</p>	<p>The definition is contained in Decree No. 264/98 art. 3. The rural area includes towns with fewer than five hundred (500) people who are at a distance greater than fifteen (15) kilometers from the boundary of Basic Rates Area (TBA) of the licensee companies historical basic telephone service.</p>

**1.b If not, how do you handle policy related issues pertaining to telecommunications/ ICTs /Broadband in rural and remote areas? (Please specify the present situation and eventual future policies) (cont'd)**

<p>Cellular Operators Association of India (COAI) (India)</p>	<p>The Government of India only has a definition for "Urban" which is:</p> <p><b>Rural and Urban areas</b></p> <p>Village or Town is recognised as the basic area of habitation. In all censuses throughout the world this dichotomy of Rural and Urban areas is recognised and the data are generally presented for the rural and urban areas separately. In the rural areas the smallest area of habitation, viz., the village generally follows the limits of a revenue village that is recognised by the normal district administration. The revenue village need not necessarily be a single agglomeration of the habitations. But the revenue village has a definite surveyed boundary and each village is a separate administrative unit with separate village accounts. It may have one or more hamlets. The entire revenue village is one unit. There may be unsurveyed villages within forests etc., where the locally recognised boundaries of each habitation area is followed within the larger unit of say the forest range officers jurisdiction.</p> <p>It is in defining the Urban areas that problems generally arise. However for the 1971 Census the definition adopted for an urban area which follows the pattern of 1961 was as follows:-</p> <p>(a) all places with a Municipality, Corporation or Cantonment or Notified Town Area</p> <p>(b) all other places which satisfied the following criteria:</p> <p>(i) a minimum population of 5,000.</p> <p>(ii) at least 75% of the male working population was non-agricultural.</p> <p>(iii) a density of population of at least 400 sq. Km. (i.e. 1000 per sq. Mile).</p> <p>The Director of Census of each State/Union Territory was, however, given some discretion in respect of some marginal cases, in consultation with the State Govt., to include some places that had other distinct urban characteristics and to exclude undeserving cases.</p> <p><b>Standard Urban areas</b></p> <p>A new concept that had been developed for the 1971 Census for the tabulation of certain urban data was the Standard Urban Area. The essential of a Standard Urban Area are :</p> <p>(i) it should have a core town of a minimum population size of 50,000,</p> <p>(ii) the contiguous areas made up of other urban as well as rural administrative units should have close mutual socio-economic links with the core town and</p> <p>(iii) the probabilities are that this entire area will get fully urbanised in a period of two to three decades.</p>
---	---

	<p>The idea is that it should be possible to provide comparable data for a definite area of urbanisation continuously for three decades which would give a meaningful picture. This replaced the concepts of Town Group that was in vogue at the 1961 Census. The town group was made up of independent urban units not necessarily contiguous to one another but were to some extent inter-dependent. The data for such town groups became incomparable from census to census as the boundaries of the towns themselves changed and the intermediate areas were left out of account; this concept came for criticism at one of the symposium of the International Geographic Union in Nov.–Dec.1968 and the concept of Standard Urban Area came to be developed for adoption at the 1971 Census. If data for this Standard Area were to be made available in the next two or three successive censuses it is likely to yield much more meaningful picture to study urbanisation around large urban nuclei.</p> <p>Ref : <a href="http://censusindia.gov.in/Data_Products/Library/Indian_perceptive_link/Census_Terms_link/censusterm.html">http://censusindia.gov.in/Data_Products/Library/Indian_perceptive_link/Census_Terms_link/censusterm.html</a></p>
Telecommunications Regulatory Authority (Lebanon)	TRA relies on the Telecommunications Law 431/2002 in preparing the regulatory framework in relation to Telecommunications. In regards to Telecommunications policy, the Ministry of Telecommunications (MOT) is in charge of drafting such policy.
The Egyptian Company for Mobile Services (MOBINIL) (Egypt)	By law, all operators must extend cellular coverage to 98% of population. Fortunately, Egypt has unique demographics: the majority of population lives in only 5%–6% of its area, around the river basin, a handful of oasis and along the sea shores. So if we cover these regions, by default, we are covering 99% of the population, whether living in urban or rural areas.
Comisión Nacional de Telecomunicaciones (CONATEL) (Paraguay)	Conatel defines, within each project, those areas of public or social interest (Zonas de interés público o social, ZIPS), which are susceptible of being subsidized. They are areas without access to the telephone service and with a population of over 1000 inhabitants (according to the 2002 census). Municipalities without broadband access also fall within this definition.
Swaziland Posts and Telecommunications Corporation (SPTC) (Swaziland)	General understanding is that rural areas are areas that are outside urban and peri-urban areas.
Post and Electronic Communications Agency (APEK) (Slovenia)	The level of development and availability of broadband networks in Slovenia varies by region. Remote, poorly developed and isolated areas in Slovenia, in which broadband networks are not developed due to market conditions, are therefore treated differently from areas in which, despite a high density of users, higher purchasing power, overall economic development and infrastructure equipment, there are still many obstacles to the more diverse and faster development of broadband networks.
Autorité de Régulation de la Poste et des Télécommunications (Dem. Rep. of the Congo)	<p>In the current context, policy-related issues are handled by operators which, pursuant to one of the clauses of their terms of reference, are required to establish themselves in rural or remote areas and provide broadband services.</p> <p>The new draft law on ICTs provides for the granting of a licence for universal service in rural or remote areas.</p>
Ministry of Information and Communication Technology (Mauritius)	There is no formal definition of rural and remote areas in Mauritius as it is a very small country/island. There are 5 cities and approximately 135 villages. Any policy issues pertaining to Telecommunications/ICTs/Broadband or any other sector applies to the whole country.
Cable Bahamas Limited (Bahamas)	The rural areas of specifically name. So in the Bahamas that would generally be all islands except New Providence and Grand Bahama.

**2 Is there any specific government policy on telecommunications/ICTs/broadband development in rural and remote areas?**

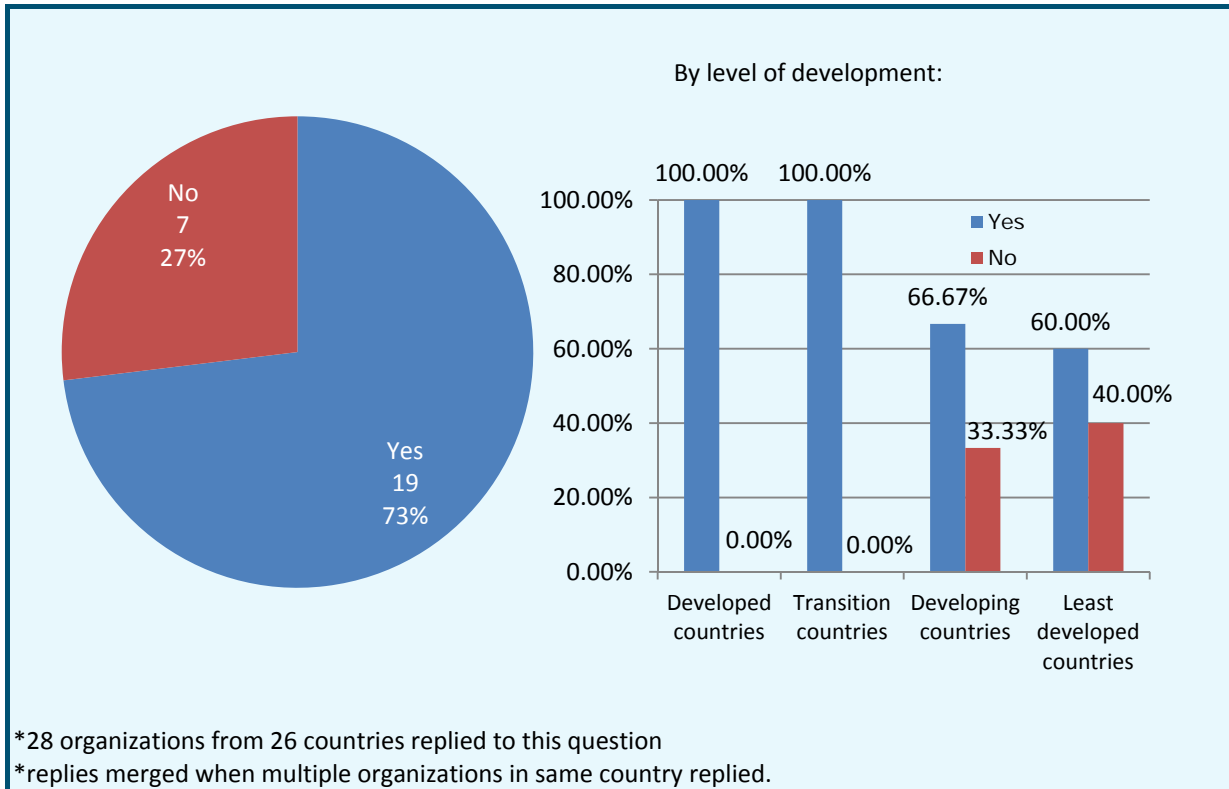

**3 If a government policy does exist, please specify which one:**

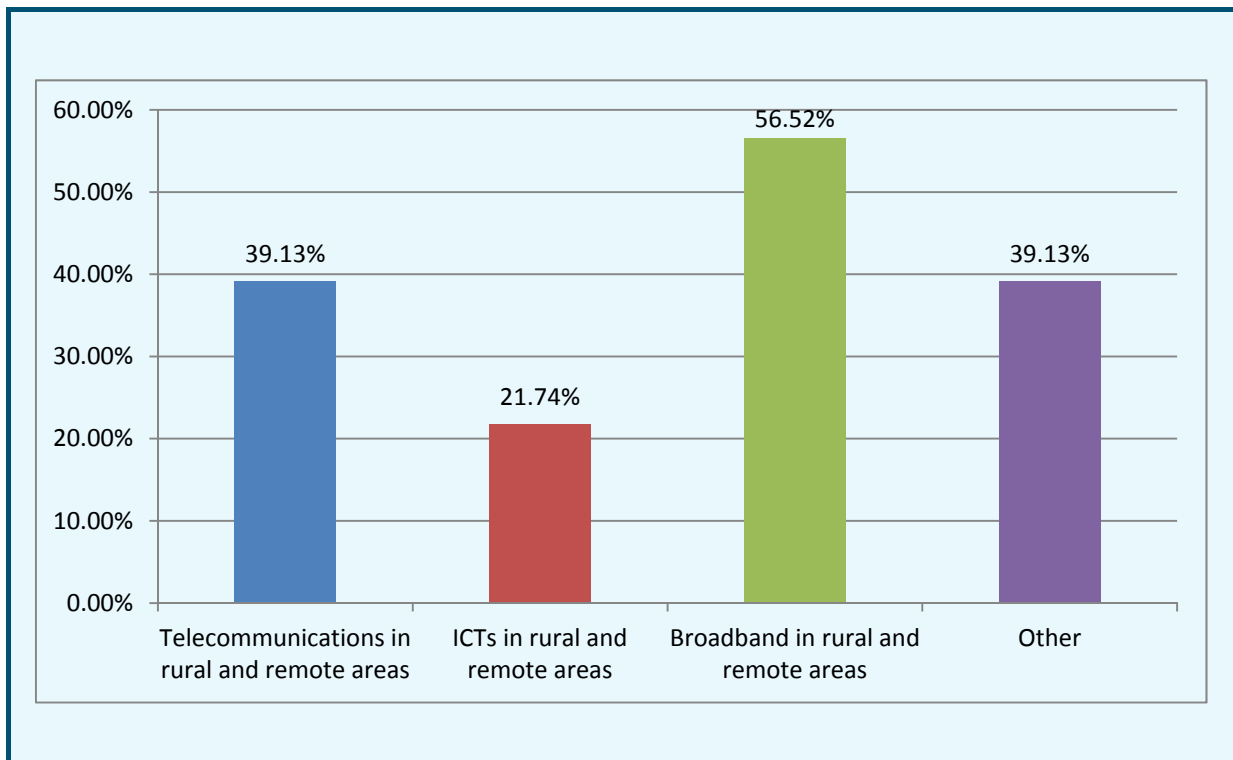



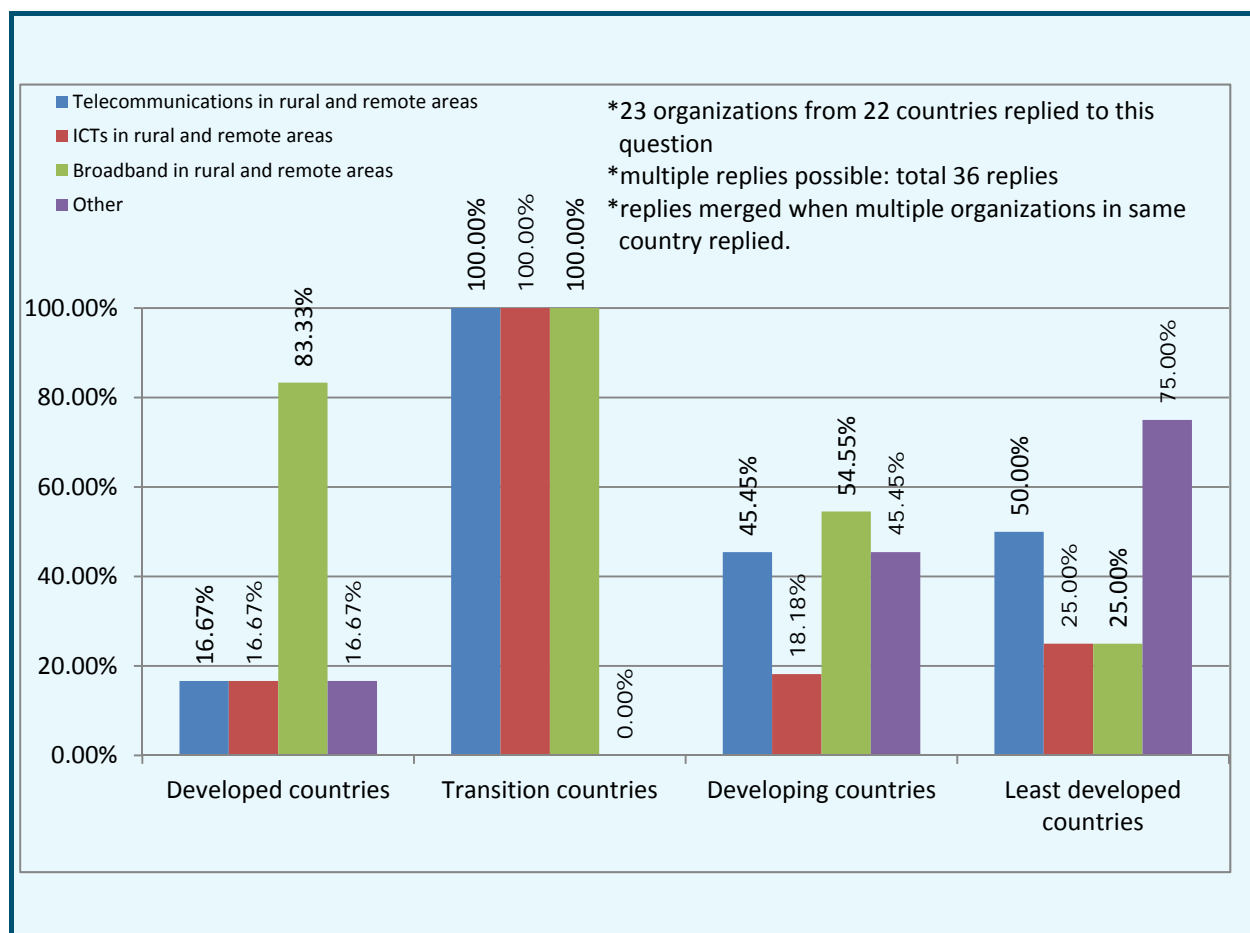

**If "Other" was selected, please specify:**

Cellular Operators Association of India (COAI) (India)	<p>The Government has mandated a 'Roll-out Condition" for provision of Telecommunication services in Rural areas . These apply only for wireless and not for wire-line. The conditions are :</p> <p>(i) Roll-out obligations shall apply for wireless network only and not for wireline network</p> <p>(ii) The Licensee shall ensure that metro service area of Delhi, Mumbai, Kolkatta and Chennai are covered within one year of date of allocation of start up spectrum.</p> <p>(iii) In non-metro service areas, the licensee shall ensure that in first phase of roll out obligation at least 10% of District HQs where startup spectrum has been allocated are covered within one year of such spectrum. The date of allocation of frequency shall be considered for computing a final date of roll-out obligation.</p> <p>(iv) Further, in second phase II of rollout obligation, the licensee shall ensure that at least 50% of DHQs, where start up spectrum has been allocated are covered within three years of date of allocation of such spectrum in non metro service areas.</p> <p>For Broadband and ICT services the Government of India has launched a major OFC plan to connect 250,000 "panchayats" i.e. lowest government office with 6 villages in its vicinity by 2014 end. This is a \$4 billion project funded by the Universal Service Obligation Fund</p>
The Egyptian Company for Mobile Services (MOBINIL) (Egypt)	There is no government policy specifically for people living in rural or remote areas.
Telecommunication & Radiocommunication Regulator (TRR) (Vanuatu)	Priority Action Agenda 2006 – 2015, Implementation policy for Millennium Challenge Goal for Vanuatu, Telecommunications Policy Statement of Vanuatu Government 2007, Universal Access Policy for ten sites, UAP Broadband Pilot Project 4 sites 2011.

Ministère de la Communication et des Nouvelles Technologies (Niger)	Two strategic approaches have been identified within the framework of the telecommunication/ICT policy: <ul style="list-style-type: none"> <li>– Promotion of universal access to ICT services</li> <li>– Development of broadband infrastructures to provide the country with national, transnational and international coverage.</li> </ul>
Comisión Nacional de Telecomunicaciones (CONATEL) (Paraguay)	According to the National Telecommunication Plan (Plan Nacional de Telecomunicaciones, PNT), the objectives for 2015 are: <ul style="list-style-type: none"> <li>– Municipalities connected by optical fibre: 200</li> <li>– Municipalities connected by broadband: 200</li> <li>– Broadband penetration: 50%</li> <li>– Digital TV penetration: 50%</li> </ul>
Nepal Telecommunications Authority (NTA) (Nepal (Republic of))	Telecommunications Policy 2004 exists which is a broad policy covering telecommunications development in rural as well as urban areas.
Post and Electronic Communications Agency (APEK) (Slovenia)	BROADBAND NETWORK DEVELOPMENT STRATEGY IN THE REPUBLIC OF SLOVENIA (2008)
Cable Bahamas Limited (Bahamas)	Television
Organismo Supervisor de Inversión Privada en Telecomunicaciones (Peru)	The established policies are designed to promote telecommunications in rural areas and places of preferential social interest. The policies are governed by the following legislation: <ul style="list-style-type: none"> <li>– Law awarding the Telecommunications Investment Fund (FITEL) legal personality under public law, assigned to the Transport and Communications sector – Law No. 28900.</li> <li>– Guidelines for the development and strengthening of competition and expansion of telecommunication services in Peru – Supreme Decree No. 003–2007–MTC.</li> <li>– General Regulatory Framework for promotion of the development of public telecommunication services in rural areas and places of preferential social interest – Supreme Decree No. 024–2008–MTC.</li> <li>– Law for the Promotion of Broadband and Construction of the National Fibre Optic Backbone Network – Law No 29904.</li> </ul>
Ministry of Internal Affairs and Communications (Japan)	National broadband plan
Oman Telecommunications Regulatory Authority (TRA) (Oman)	Universal Service Policy and Implementation Strategy
Ministry of Information and Communication Technology (Mauritius)	National Broadband Policy 2012–2020 <a href="http://www.gov.mu/portal/goc/telecomit/file/NationalBroadband.pdf">www.gov.mu/portal/goc/telecomit/file/NationalBroadband.pdf</a> It is inclusive in the National Policy for the whole country
Rwanda Utilities Regulatory Authority (RURA) (Rwanda)	Broadcasting policy focusing on transition from Analog to Digital

#### 4 What are the major features of such a policy ? (Please make 2 or 3 proposals of these features)

Cellular Operators Association of India (COAI) (India)	<p>The major features of this above and the recently announced National Telecom Policy (NTP) 2012 are:–</p> <p>Tele-density: Increase in rural tele-density from 35% to 100% by 2020</p> <p>Broadband: 175 million by 2015, Broadband on demand by 2015 and 600 million connections by 2020</p> <p>National Optical Fibre Network (NOFN) High speed and high quality broadband access to all village panchayats through a combination of technologies by the year 2014.</p> <p>Download speed to be increased from 512 Kbps to 2Mbps</p> <p>Leveraging USO funds for faster expansion of broadband</p>
Servei de Telecomunicacions d'Andorra (STA) (Andorra)	All telecommunications services in Andorra are universal, that is, the same service is provided with the same quality and price for the whole of the population.
ABI Research (United States) (United Kingdom)	<ul style="list-style-type: none"> <li>– BDUK management and allocation of £530 million for the 'final third'</li> <li>– The Mobile Infrastructure Project (MIP);</li> <li>– Superconnected Cities;</li> <li>– Rural Community Broadband Fund (DEFRA);</li> </ul> <p>The Broadband Task Force (November 2002) established with a remit to work on extending affordable broadband access especially in rural areas. The Task Force has developed the Broadband Aggregation Project, which aggregates public sector demand including in rural and remote areas. In May 2003, a new Rural Broadband Unit was created in the Department of Trade and Industry. Working with the Department of Environment, Food and Rural Affairs and Regional Development Agencies, their role will be to identify ways of accelerating the availability of broadband access in rural areas.</p>
Telecommunications Regulatory Authority (Lebanon)	Remote areas (remote villages and villages with mountainous terrain) are being interconnected over fixed wireless services provided by the MOT. In addition, such connections provide voice as well as Broadband data services.
Ministerio de Tecnologías de la Información y las Comunicaciones (Colombia)	They are included in the national development plan and, in general, are contained in universal access goal frameworks, together with appropriation strategies.
Telecommunication & Radiocommunication Regulator (TRR) (Vanuatu)	Improving access to telecommunications service for locations which are not or not adequately served by existing services at affordable prices to the consumers, PAA 2006–2015, Telecom Policy Statement new entrant with license obligation for 85% coverage after two years of operations (access to voice and data). UAP Ten sites for remote uneconomic locations, UAP Broadband Pilot Project to pilot the connect school, connect community initiative with a view to replicate the concept to other remote locations.
Ministère de la Communication et des Nouvelles Technologies (Niger)	<ul style="list-style-type: none"> <li>– Implementation of a digital literacy programme through the creation of community centres providing such training to the public</li> <li>– Implementation of a “Connect a school, connect a community” programme</li> <li>– Project for the creation of an agency to manage the universal access fund.</li> </ul>
Syrian Telecommunication Regulatory Authority (SyTRA) (Syrian Arab Republic)	<ul style="list-style-type: none"> <li>• The establishment of a special scheme to serve rural areas (Rural schemes 1, 2 and 3)</li> <li>• The provision of telecommunication services to all rural areas regardless of economic feasibility</li> <li>• Consideration given to making use of all available technical resources to serve rural areas.</li> </ul>

Comisión Nacional de Telecomunicaciones (CONATEL) (Paraguay)	<ul style="list-style-type: none"> <li>– Encourage private investment in infrastructure</li> <li>– Subsidy by Conatel wherever required</li> <li>– Improve the quality of services</li> </ul>
Nepal Telecommunications Authority (NTA) (Nepal (Republic of))	<ul style="list-style-type: none"> <li>i. Telecommunications service shall be available at shouting distance</li> <li>ii. Telecommunications service shall be made available to the consumers through shared telephone and other services pertaining to ICT through community centers</li> <li>iii. ICT services in rural areas will be made available through small service providers i.e. license fee and annual fees will be waived if the annual income is less than US\$ 250,000</li> </ul>
CATR of Ministry of Industry and Information Technology (MIIT) (China)	Universal telecommunication service
Post and Electronic Communications Agency (APEK) (Slovenia)	The broadband network development strategy is therefore a document that defines in great detail the development of broadband networks within the framework of the RSvID strategy. The strategy reflects the movement of European Union's political guidelines, which emphasise the necessity for European states to catch up with more developed markets regarding the use of ICT. The general opinion is that the freeing up of the electronic communications services markets is of key importance in the attainment of the Lisbon objectives. The freeing of markets and competition in OECD countries have, for example, reduced prices, and the provision of new products and services has encouraged investment and demand for communications access and services, from which positive social effects and related new knowledge and skills of users have been identified.
AHCIET (Colombia)	<ul style="list-style-type: none"> <li>– Public – private collaboration in designing investment and service delivery.</li> <li>– Expanding public use of the Internet by developing the necessary infrastructure to meet the requirements for broadband Internet access and all the services derived from it, with the ultimate goal of eliminating the digital divide, stimulating user demand, and developing applications that apply the technology and develop content (setting up technocentres and training centres). Setting up e-government services and strengthening the ICT industry.</li> <li>– Developing a fibre optic network and allocating subsidies for fixed broadband consumption.</li> </ul>
Organismo Supervisor de Inversión Privada en Telecomunicaciones (Peru)	<p>Policies exist for the provision of universal access. They are implemented by the Telecommunications Investment Fund (FITEL) (Law awarding the Telecommunications Investment Fund (FITEL) legal personality under public law, assigned to the Transport and Communications sector – Law No. 28900).</p> <p>There is also a Rural Service Tariff System, applied to communications between users of the public telephone service in rural areas and places of preferential social interest (Resolution of the Governing Council of the Supervisory Authority for Private Investment in Telecommunications – OSIPTEL No. 022–99–CD/OSIPTEL).</p> <p>In addition, differentiated interconnection charge schemes have been introduced for rural areas (Consolidated Amended Text of Interconnection Regulations – Governing Council Resolution No. 134–2012–CD/OSIPTEL).</p> <p>Also under way is the procedure for regulating rural charge and tariff caps (Regulation of Tariff Caps and Interconnection Charges Applicable in the Provision of the Fixed Telephone Service in Rural Areas and Places of Preferential Social Interest – Resolution No. 024–2008–CD/OSIPTEL).</p>
Ministry of Communications and Informatization (Belarus)	<p>Development of data transmission network infrastructure with a view to achieving maximum coverage of the country's population in terms of broadband access, using new (including wireless) data transmission technologies;</p> <p>Modernization of existing fibre optic communications infrastructure using modern transmission systems.</p>

<p>Agência Nacional de Telecomunicações – ANATEL (Brazil)</p>	<p>Bidings on public auctions for radiofrequency specify obligations towards offering telecommunications in rural and remote areas, like auction for frequencies 451MHz to 458MHz, that established that winners would have to: offer telecommunication services in rural and remote areas; offer broadband access, free of charge, to public rural schools in the service areas; interconnect at low prices with small telecommunications companies; and cover up a radius of 30km from the urban boundaries. Also PSTN incumbents must deploy public telephone booths near specific buildings like public schools, healthcare centers etc.</p>
<p>Ministry of Internal Affairs and Communications (Japan)</p>	<p>Support from the government to local governments based on the state-funded privatized plan implementation integrated with introduction of public applications</p>
<p>Ministry of Transport of the Republic of Latvia (Latvia)</p>	<p>In 2012 Latvian Government approved a policy planning document "The broadband network development 2013–2020".</p> <p>Latvian National broadband plan meet the coverage, speed and take-up targets defined in the Digital Agenda for Europe. The Latvian population of regions will be ensured fast, high quality access to resources on the Internet.</p> <p>Targeted state aid in the field of broadband services can help to reduce the isolation of the country between areas, which offers a competitive broadband services at an affordable price, and the territories, that such services do not.</p> <p>In 2011 the European Commission approved State Aid scheme “Next Generation Network for rural area”, which foresees support to development and establishment of the infrastructure to provide wholesale broadband services in rural areas of Latvia, which are currently not served and where are no plans for development of next generation network in the near future– three year period.</p> <p>The scope of the aid scheme is to support next generation network (NGN) project, witch will ensure:</p> <ul style="list-style-type: none"> <li>– connection to NGN local governments (centre of municipality) and administrative entities (centres of rural territories, schools, hospitals, ambulances, libraries etc.);</li> <li>– possibility to get NGN service in 100% of Latvian rural territory.</li> </ul>
<p>Oman Telecommunications Regulatory Authority (TRA) (Oman)</p>	<p>1. providing voice services to unserved areas providing internet services with a minimum speed of 512 kbs to the public providing internet services with a minimum speed of 2 Mbs to government institution such as schools , health centres. police stations</p>
<p>Ministry of Information and Communication Technology (Mauritius)</p>	<p>1. By 2014, at least 60% of homes should have affordable access to actual download speeds of at least 10 Mbps and actual upload speeds of at least 5 Mbps; and by 2020, almost 100% of home should have affordable access to actual download of 100 Mbps.</p> <p>2. By 2020, every public institution should have affordable access to at least 100 Mbps broadband service to anchor institutions such as schools, hospitals and government buildings.</p>
<p>Rwanda Utilities Regulatory Authority (RURA) (Rwanda)</p>	<p>Operator network rollout plan is part of bidding documents for Operator license contain plans on how the rural and remote area will be covered</p> <p>The rollout plan is part of license obligation</p> <p>Optic Network covering the whole country</p> <p>VSAT network for remote areas</p> <p>Universal Access Fund for subsidy of connectivity in rural and remote area</p> <p>Legal and regulatory framework for open competition and technological neutral</p>
<p>Cable Bahamas Limited (Bahamas)</p>	<p>Provision of fixed voice to populated areas in the islands, high speed data services and connectivity as well as basic dial-up internet. A six channel television service (two of the channels have to be Government's run station).</p>

<p>ICP – Autoridade Nacional de Comunicações (ANACOM) (Portugal)</p>	<p>NGAs (very high-speed broadband) in rural areas can contribute to equality of opportunity for all citizens, promoting info-inclusion and the development of human capital and contributing to the creation of externalities in rural development policy at the level of employment, growth, competitiveness and sustainability of the industries located in these areas.</p> <p>In order to ensure territorial cohesion and to uphold equality of opportunity, in 2009 the Government decided to launch five Public Tenders for the construction, installation, financing, operation and maintenance of NGA, with co-financing, with the aim of addressing possible market failures in 139 municipalities, divided into five regions (the Centre, Alentejo and Algarve, North, Madeira and the Azores). The municipalities covered in each of these areas are those without coaxial cable networks and without co-located operators and when all the parishes comprising the municipality are classified as rural by the European Agricultural Fund for Rural Development (EAFRD).</p>
<p>Comisión Nacional de Comunicaciones (CNC) (Argentina)</p>	<p>Promote the development of telecommunications infrastructure throughout the country and provide universal Internet access.</p> <p>Achieving social inclusion of vulnerable sections of society.</p> <p>Encourage ownership and benefits of ICT to the less favorecidos.ya children of school age.</p> <p>Telephone and Internet Program for towns without provision of basic telephone service. For areas with less than 250 inhabitants, the object is the provision of local telephone service, long distance and international and as optional internet access. For locations with more than 250 inhabitants, the object is the provision of local telephone service, long distance and international together with internet access.</p>

**5 If no specific government policy on Telecommunications/ICTs/Broadband exists, how are the issues of Telecommunications/ICTs/Broadband in rural and remote areas being handled?**

<p>Telecommunications Regulatory Authority (Lebanon)</p>	<p>See question 4.</p>
<p>The Egyptian Company for Mobile Services (MOBINIL) (Egypt)</p>	<p>Handled like any other area. There is a cellular network and coverage that is controlled and monitored by the company – and the government – similarly.</p> <p>In case of say, a complaint, it is reported to the Ministry of ICT or the Consumer Protection Agencies – or – the company itself and is handled as per the existing process and within the framework of the law.</p>
<p>Telecommunication &amp; Radiocommunication Regulator (TRR) (Vanuatu)</p>	<p>Where there is no specific government policy, Regulator in tasked with development of telecommunications services with consultation with the operators. Office of the ICT under the ministry is responsible for ICT to government agencies and schools and health centers. Competitive Market also drives expansion of telecommunications/ICT/Broadband into rural and remote areas of Vanuatu.</p>
<p>Comisión Nacional de Telecomunicaciones (CONATEL) (Paraguay)</p>	<p>The National Telecommunication Plan (Plan Nacional de Telecomunicaciones, PNT) is the policy implemented by Conatel, as government regulator.</p>
<p>Nepal Telecommunications Authority (NTA) (Nepal (Republic of))</p>	<p>Using the provisions available in</p> <ol style="list-style-type: none"> <li>Telecommunications Act, 1997</li> <li>Telecommunications Regulation, 1998</li> <li>Telecommunications Policy, 2004</li> <li>RTDF Disbursement bylaw</li> </ol>
<p>Swaziland Posts and Telecommunications Corporation (SPTC) (Swaziland)</p>	<p>Swaziland is currently using the Universal Service Obligation draft policy to service the rural underserved remote areas.</p>

Autorité de Régulation de la Poste et des Télécommunications (Dem. Rep. of the Congo)	In line with the obligations stipulated in their terms of reference, operators seek to introduce appropriate solutions in the rural or remote areas in which they are established.
Office of the President, Department of Information Communication Technology (Seychelles)	National ICT Policy 2007
Oman Telecommunications Regulatory Authority (TRA) (Oman)	TRA imposed certain license obligations in the telecom service providers to cover some remote areas with set of telecom services which was very helpful
Ministry of Information and Communication Technology (Mauritius)	The same policy applies to the whole country.

**6 Is this a part of the national telecommunication/ICTs/broadband policy?**

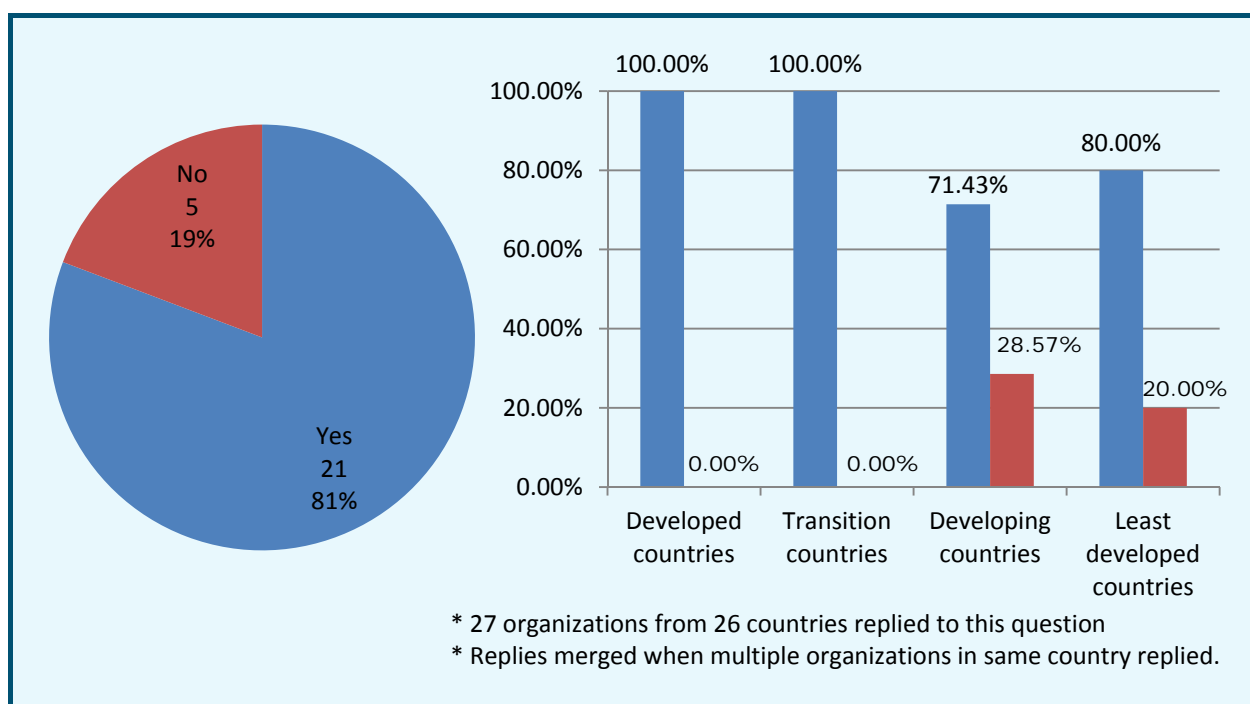

**7 If it is part of the national telecommunication/ICT/Broadband policy, what provisions are made in the broad policy framework?**

Cellular Operators Association of India (COAI) (India)	<p><b>Key Highlights of the Policy</b></p> <ul style="list-style-type: none"> <li>Infrastructure status to the telecom sector</li> <li>'One nation-one license'</li> <li>Inclusive growth by focusing on rural market</li> <li>License issuance de-linked from spectrum allocation</li> <li>Future spectrum allocations at market valuations</li> <li>Trading, sharing and pooling of spectrum to be permitted</li> <li>'Right to Broadband'</li> <li>Focus on indigenization of telecom equipment products and equipment</li> </ul>
--	--

	<p>Convergence of voice, data, video, Internet, multimedia, broadcasting and value added services</p> <p>Spectrum: 500 MHz to be made available of which</p> <p>300 MHz of spectrum to be made available for IMT services by 2017</p> <p>Another 200 MHz of spectrum to be made available by 2020</p>
Servei de Telecomunicacions d'Andorra (STA) (Andorra)	All telecommunications services in Andorra are universal, that is, the same service is provided with the same quality and price for the whole of the population.
ABI Research (United States) (United Kingdom)	<p>Four rural areas that include some of the most remote and geographically challenging parts of the UK were selected in 2010 to pilot the next generation of high speed broadband.</p> <p>Each area is allocated around £5–10m from a total of £530m funding to support the roll-out of broadband until 2015 to areas that the market alone will not reach.</p> <p>Parts of Cumbria, the Highlands and Islands, North Yorkshire and the Golden Valley in Herefordshire will all be connected at speeds only usually found in densely populated urban areas.</p>
Ministerio de Tecnologías de la Información y las Comunicaciones (Colombia)	In Colombia, national ICT policy is embodied in the Plan Vive Digital, integrated by the various dimensions of the digital ecosystem, that is: users, infrastructure, services and applications, and where each of these components has had its own goals and objectives developed.
Telecommunication & Radiocommunication Regulator (TRR) (Vanuatu)	Broad Policy Framework is set out in PAA 2006 – 2015 in line with MDG for Vanuatu, specific provision for establishment of liberalised telecommunications market was set out in the 2007 Telecommunications Statement of Vanuatu Government, outlining the regulatory framework, developed into the unilateral Telecom Licences and new telecommunications and radiocommunications legislation in 2009. UAP Policy in 2010 sets out remote telecommunications infrastructure for 10 sites.
Ministère de la Communication et des Nouvelles Technologies (Niger)	<p>The President of the Republic of Niger's programme of recognition includes the Plan for Economic and Social Development (PDES 2012–2015).</p> <p>Within this subsector, the PDES will focus on the development of information and communication technologies capable of satisfying the modernization requirements of the economic sectors. This will entail consolidating the achievements made to date while at the same time developing new, innovative programmes and projects to build up the information society, through:</p> <p>(i) the establishment of an enabling legal and institutional environment in the telecom/ICT sphere; (ii) the creation of a technology and infrastructure environment conducive to telecom/ICT development; (iii) support for the implementation of sectoral ICT strategies; (iv) the pursuit of communication, training, research and capacity-building activities in the ICT sphere; (v) the promotion of access to modern postal services throughout the country.</p>
Syrian Telecommunication Regulatory Authority (SyTRA) (Syrian Arab Republic)	A universal service fund was created pursuant to the 2010 telecommunication law.
Comisión Nacional de Telecomunicaciones (CONATEL) (Paraguay)	A National Broadband Plan does not yet exist. The PNT is the current framework.
Nepal Telecommunications Authority (NTA) (Nepal Republic of)	<p>Provisions in broad sense for rural development:</p> <p>a. Telecommunications Act, 1997 has the provisions that the operators have to invest 15% of their annual investment in rural areas.</p> <p>b. Telecommunications Regulation, 1998 has mandated the regulator to collect 2% of AGR from service provider as contribution to the RTDF (USO) fund</p> <p>c. Telecommunication Policy has the provisions:</p> <p>i. Telecommunications service shall be available at shouting distance</p> <p>ii. Telecommunications service shall be made available to the consumers through shared telephone and other services pertaining to ICT through community centers</p>



	<p>iii. ICT services in rural areas will be made available through small service providers i.e. license fee and annual fees will be waived if the annual income is less than US\$ 250,000</p> <p>d. District optical fiber network (DOFN) project document has been developed and has been expected to utilizing the RTDF fund</p> <p>e. In technical collaboration with the ITU, NTA has developed "Wireless Broadband Master Plan" which has provisions for rural development</p> <p>f. The Draft Broadband Policy has also been developed which also focuses on rural telecommunications development .</p>
CATR of Ministry of Industry and Information Technology (MIIT) (China)	Universal telecommunication service
Post and Electronic Communications Agency (APEK) (Slovenia)	<p>Broadband Network Development Strategy in RS is a document intended for economy, civil society, state and public administration bodies of RS, or any participants in the field of electronic communications who are or will actively participate in the transition to a developed and advanced information society.</p> <p>The strategy represents an improvement and upgrade of the document Broadband network development strategy in the Republic of Slovenia adopted by the Slovenian Government in 2004.</p>
AHCIET (Colombia)	<ul style="list-style-type: none"> <li>– Deployment of a fibre optic network and allocation of subsidies for fixed broadband consumption.</li> <li>– Ensure that 50 per cent of households and SMEs have Internet connection.</li> <li>– Quadruple the current number of Internet connections.</li> <li>– Triple the number of municipalities with fibre optic Internet connection.</li> <li>– By 2014, ensure that 50 per cent of households have a connection capacity of at least 1 Mbps. Guarantee that all towns of more than 100 inhabitants have at least one communal Internet access point.</li> <li>– Increase the total number of connections from 2.2 million to 8.8 million by 2014, and increase the current number of local authorities connected from 300 to 700.</li> <li>– Ensure that 50 per cent of households are connected (25 per cent currently).</li> </ul>
Organismo Supervisor de Inversión Privada en Telecomunicaciones (Peru)	Regulations applicable nationwide are established by both OSIPTEL and the Ministry of Transport and Communications. The former is responsible for regulating and supervising the public telecommunication services market, the former for putting forward policies to promote the development of communication services and universal access to them.
Ministry of Communications and Informatization (Belarus)	The National Programme for accelerated development of ICT services for 2011–2015 was adopted by Council of Ministers Order No. 384 of 28 March 2011.
Agência Nacional de Telecomunicações – ANATEL (Brazil)	The National Broadband Plan, created by Decret 175/2010, defines the Ministry of Communications, a public company (Telebrás) and the regulation agency (Anatel) as responsible for the plan. Also, the incumbents signed treaties to fund certain aspects of the Plan, like offering broadband access at low prices.
Ministry of Internal Affairs and Communications (Japan)	Approvals of preparation plans, grants, guarantees for debts.
Ministry of Transport of the Republic of Latvia (Latvia)	<p>In 2012 Latvian Government approved a policy planning document „The broadband network development 2013–2020”.</p> <p>In January 2012 was adopted the Government’s Regulation on the implementation of the EU funded broadband development project „Next Generation Network for rural area”.</p> <p>In 2012 was approved „Latvian national development plan in 2014 to 2020 (NAP2020)”.</p>

Office of the President, Department of Information Communication Technology (Seychelles)	<ul style="list-style-type: none"> <li>– Promote and encourage the existence of a countrywide reliable and efficient ICT infrastructure which shall have sufficient capacity and network speeds, provide improved connectivity, be cost-effective and adaptive to the needs of the country.</li> <li>– Promote widespread accessibility to ICT services.</li> <li>– Promote and encourage deployment and maintenance of networks that are interoperable on a national basis.</li> </ul>
Rwanda Utilities Regulatory Authority (RURA) (Rwanda)	Broadband policy currently under development
ICP – Autoridade Nacional de Comunicações (ANACOM) (Portugal)	<p>In Portugal, a Resolution of the Council of Ministers of July 2008 determined that the investment on next generation access networks should be deemed as one of the strategic priorities for the Country as far as the electronic communications sector is concerned. The Government took the responsibility to evaluate the measures that could be adopted in order to foster the development of next generation networks, namely in geographical areas with low broadband penetration, as well as to modernize network infrastructure. Accordingly, and considering NGA as a generator of economic opportunities, training and development, the Portuguese government launched in 2009 the above mentioned five Public Tenders for the installation and operation of "High-Speed Networks in Rural Areas", covering 139 municipalities, which are currently being deployed and open for service during 2013.</p> <p>Currently, the Digital Agenda for Portugal, published in Diário da República (Official Journal) on 31 December (Resolution of the Council of Ministers no. 112/2012), aims to stimulate the digital economy and the information, communications and electronics technologies sector, through the use and development of tradable and competitive goods and services for international markets. Portugal's (new) National Agenda envisages strong involvement by civil society and by the private sector, especially in the information and communication technologies (ICT) sector, entailing the launch of a raft of initial measures to be implemented by 2016, in the following six action areas:</p> <ul style="list-style-type: none"> <li>• broadband access and access to the digital market;</li> <li>• investment in research and development (R&amp;D) and innovation;</li> <li>• improving digital literacy, inclusion and qualification;</li> <li>• combating tax and contributory fraud and evasion;</li> <li>• addressing societal challenges;</li> <li>• entrepreneurship and internationalization of the ICT sector.</li> </ul> <p>The Digital Agenda for Portugal sets out the following objectives:</p> <ul style="list-style-type: none"> <li>• promote the development of broadband infrastructure so that citizens have access to broadband speeds of 30 Mbps or more, by 2020;</li> <li>• promote the development of broadband infrastructure so that 50 per cent of households have access to broadband Internet with speeds of 100 Mbps or more, by 2020;</li> <li>• create conditions enabling an increase of 50 percent, compared to 2011, in the number of businesses using e-commerce in Portugal by 2016;</li> <li>• promote the use of online public services, so that they are used by 50 percent of the population, by 2016;</li> <li>• create conditions enabling a 20 percent increase in ICT exports, in accumulated terms, by 2016, over 2011;</li> <li>• promote the use of new technologies, so that the number of people who have never used the internet can be reduced by 30 percent, by 2016.</li> </ul>
Cable Bahamas Limited (Bahamas)	The provisions in the policy framework provide for it under the Universal Service Obligations.

<p>Comisión Nacional de Comunicaciones (CNC) (Argentina)</p>	<p>Argentina Connected is a comprehensive five-year plan defining infrastructure and telecommunications services for the entire country. The aim is to achieve the deployment of national infrastructure to ensure access to ICT to the population and, through investment in its development, obtain a reduction in service costs. This National Plan seeks to expand broadband connectivity through the development of a national fiber optic network and thereby reduce the digital divide between citizens and the different areas of the country. The goal is to reach the year 2015 with 10 million connected households.</p> <p>The strategic axes defined in the policy are:</p> <p>Digital Inclusion: which aims to ensure the benefits of new technologies to all Argentines equal, enshrining the right of access to information, through greater connectivity and full convergence of networks and services.</p> <p>Optimizing the Use of Radio Spectrum: since it is an essential and finite resource to achieve the functionality of the telecommunications sector. It is also planning priority derivative of the digital dividend spectrum, caused by the adoption of a standard for digital television.</p> <p>Universal Service Development: is intended that the services and programs defined by the National reach citizens regardless of their geographical location and their social and economic conditions, promoting their development through existing funds in the Universal Service.</p> <p>National Production and Employment Generation Telecommunications Sector: it seeks to promote the growth of the sector, and to promote strategic alliances between public and private sector that results in new jobs, higher grade, either in the preparation of the necessary equipment for the deployment of infrastructure and related items.</p> <p>Training and Research in Communications Technology: With the deployment of the services shall worked in parallel on an academic who is at the height of technological change and generate new professionals and researchers trained to accompany and contribute in the process.</p> <p>Infrastructure and Connectivity: to achieve the planned infrastructure development is necessary to coordinate the existing connectivity plans with the needs of the villages still have no connection, to focus on the deployment of the network effectively and efficiently.</p> <p>Enhance Competition: With the development of fiber optic network intended that municipal / provincial advocate to the provision of last mile which will result in a greater number of service providers, either through telephone cooperatives , small businesses and new entrants.</p>
--	--

**8 If it is not part of the national Telecommunication/ICT/Broadband policy, is there any project in the future for it to become part of it?**

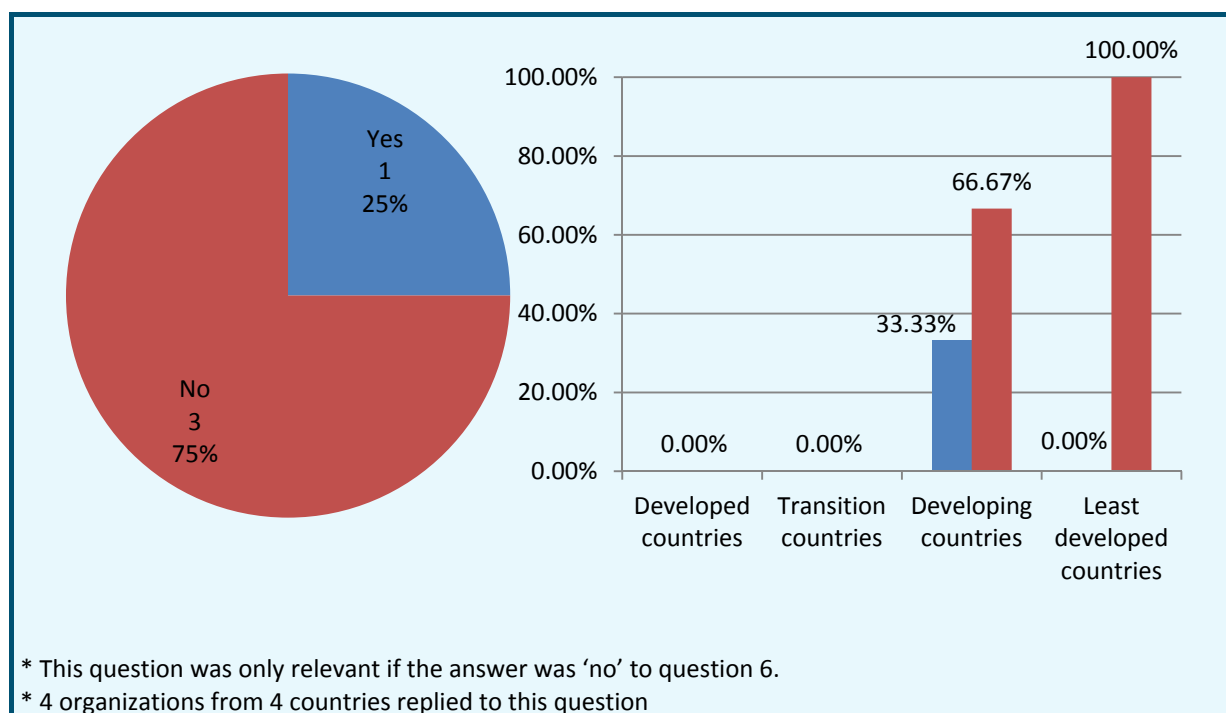

**Please specify in either case:**

Telecommunications Regulatory Authority (Lebanon)	It is expected to be part of the policy that will be issued by the MOT, in addition the TRA has the responsibility to implement universal service and ensure service to remote and rural areas.
The Egyptian Company for Mobile Services (MOBINIL) (Egypt)	If there is, then i am not aware of. All i know is that the Ministry of ICT follows the evolution of the cellular network and ensures that the required KPI like call drop rate or call block rate or other indicators are met.
Telecommunication & Radiocommunication Regulator (TRR) (Vanuatu)	Connect Schools, Connect Community initiative is being piloted, lessons learn and concept could be rollout into other remote areas, improving broadband access to schools and community through use of community telecenters in the remote areas.
Ministère de la Communication et des Nouvelles Technologies (Niger)	ICT development in remote or rural areas is an integral part of the national policy on universal access.
Comisión Nacional de Telecomunicaciones (CONATEL) (Paraguay)	It is expected that, in the near future, a National Broadband Plan will be implemented, which will cover government and society.
Swaziland Posts and Telecommunications Corporation (SPTC) (Swaziland)	Swaziland has an approved National Information & Communications Infrastructure Policy which is not specifically for rural remote areas, however, it does alude to universal access.
Autorité de Régulation de la Poste et des Télécommunications (Dem. Rep. of the Congo)	It is planned to elaborate a national policy on broadband in rural or remote areas.

**9 Is the Telecommunications/ICT/Broadband in rural and remote areas considered a universal service/access obligation?**

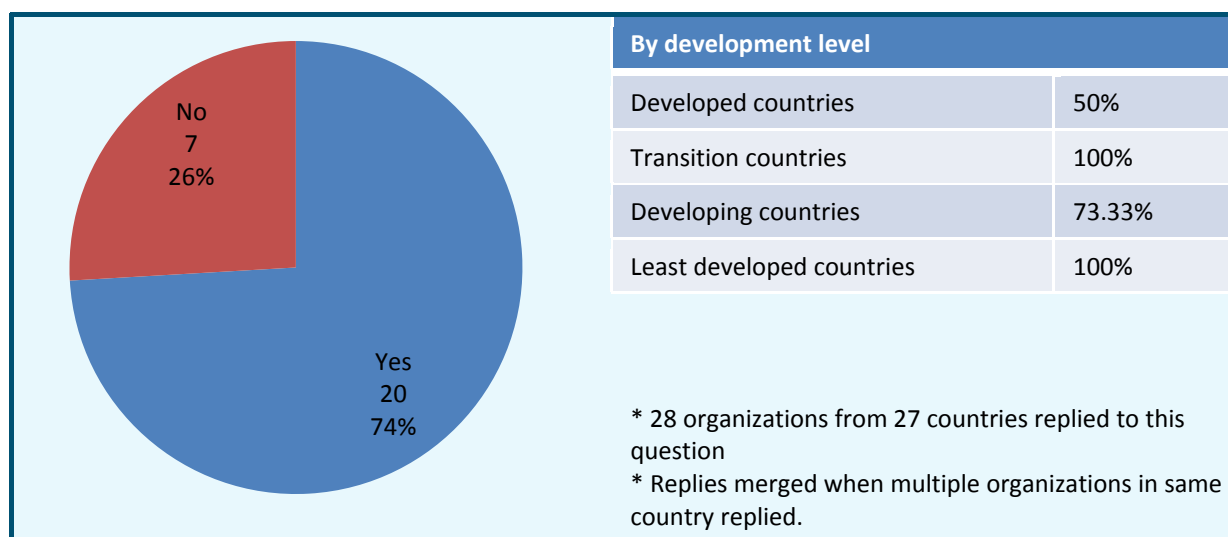

**10 How is that obligation defined?**

<p>Cellular Operators Association of India (COAI) (India)</p>	<p>All telecom operators give 5% of their Annual Gross Revenue as their contribution to the USO Fund. The Government, through the USO Fund administrator brings out schemes for extending telecom and ICT services to the rural areas. Currently the following schemes are under execution in India.</p> <p><b>Stream-I:</b> Provision of Public Access Service:</p> <p><b>Stream-II:</b> Provision of Household Telephones in Rural and Remote Areas as may be Determined by the Central Government from Time to Time:</p> <p><b>Stream-III:</b> Creation of Infrastructure for provision of Mobile Services in Rural and Remote Areas. The assets constituting the infrastructure for provision of mobile services shall be determined by the Central Government from time to time (Mobile Infrastructure (Phase-I)).</p> <p><b>Stream-IV:</b> Provision of Broadband Connectivity to rural &amp; remote areas in a phased manner (Wire Line Broadband, Rural Public Service Terminals (RPST)).</p> <p><b>Stream-V:</b> Creation of General Infrastructure in Rural and Remote Areas for Development of Telecommunication facilities. The items of general infrastructure to be taken up for development shall be determined by the Central Government from time to time (Optical Fiber Cable(OFC) for Assam).</p> <p><b>Stream-VI:</b> Induction of new technological developments in the telecom sector in Rural and Remote Areas: Pilot projects to establish new technological developments in the telecom sector, which can be deployed in the Rural and Remote Areas, may be supported with the approval of the Central Government (Solar Mobile Charging Facility(SMCF)).</p> <p>In addition there are two Special Schemes as below:-</p> <ul style="list-style-type: none"> <li>- Gender based Schemes</li> </ul> <p>In recognition of the requirements of Gender Responsive Budgeting, preferential allocation of broadband connections to women's SHGs has been incorporated in the USOF Wire Line Broadband Scheme. Further, a special scheme for provisions of broadband enabled Rural Public Service Terminals to SHGs has been incorporated in the Fund's activities. These terminals will enable SHGs to provide banking, financial services and other broadband enabled Value Added Services (VAS) to the rural population.</p>
---	---

	<p>– Sanchar Shakti</p> <p>In addition, USOF intends to initiate a series of pilots aimed at empowerment of women through mobile VAS and ICT related skills. The focus of activity shall be women’s SHGs. Seven projects have been accepted by competent authority for signing of MoU for Proof of Concept.</p> <p>2. ICT for Persons With Disabilities (PWD). This is under finalisation.</p> <p>Objectives of the Scheme</p> <p>2.1 Primary objective of the scheme is to provide PwDs in rural India with meaningful access to telecommunications facilities and through telecommunications facilities enable them to access public services, information, educational and employment opportunities thereby helping them to achieve self-reliance and facilitate their inclusion in mainstream society.</p> <p>2.2 The scheme, via pilot projects, seeks to effectively demonstrate and highlight the utility and benefits of AT enabled ICTs to PwDs and their families in rural India and to institutions/organizations dealing with PwDs and to service providers, equipment manufacturers and content providers etc. The scheme seeks to encourage service providers and other stakeholders to take up such initiatives on a larger scale in order to address the needs of PwDs.</p>
Servei de Telecomunicacions d'Andorra (STA) (Andorra)	All telecommunications services in Andorra are universal, that is, the same service is provided with the same quality and price for the whole of the population.
ABI Research (United States) (United Kingdom)	<p>It is currently only defined as a "commitment" by Ofcom. Both BT and KCom are subject to a Universal Service Obligation which requires them to provide a telephone line to any household that requests one, subject to a 'reasonable cost' limit (currently set at £3400 by BT). As a result the vast majority of consumers are able to get a fixed telephone line if they wish.</p> <p>The Universal Service Obligation requires that a telephone line must support "functional internet access". However, the directive was written before broadband was prevalent and, in the UK, the obligations currently only extend to the provision of a line that is capable of supporting dial-up modem connections of 28kbit/s.</p>
The Egyptian Company for Mobile Services (MOBINIL) (Egypt)	Just recently this Universal Service has surfaced. I am aware that there are very remote areas in central Sinai that may finally benefit from this fund.
Ministerio de Tecnologías de la Información y las Comunicaci (Colombia)	In Colombia, the law gives priority to access goals instead of services and these are defined by the provision of coverage or services in areas outside the market.
Telecommunication & Radiocommunication Regulator (TRR) (Vanuatu)	The obligation is defined with the Telecommunications licenses and Telecommunications and Radio-communications Act, as improving access to telecommunications service for locations which are not or not adequately served by existing services. These are developed by the Government in consultation the operators. Regulator performs the administration functions of implementing and monitoring the obligations on behalf of the Government.
Ministère de la Communication et des Nouvelles Technologies (Niger)	It is an obligation that enables the State to ensure ICT connectivity in remote areas deemed to be unprofitable.
Nepal Telecommunications Authority (NTA) (Nepal (Republic of))	<p>Obligations:</p> <p>a. Telecommunications Act, 1997 has the provisions that the operators have to invest 15% of their annual investment in rural areas.</p> <p>b. Telecommunications service shall be made available at shouting distance (at least two telephone lines/public call office in a VDC)</p>

CATR of Ministry of Industry and Information Technology (MIIT) (China)	A telecommunication service provider shall fulfill its universal telecommunication service obligations in accordance with various national regulations. The agency responsible for information industry under the State Council may determine specific universal telecommunication service obligations for each telecommunication service provider by means of designation or public bidding.
Swaziland Posts and Telecommunications Corporation (SPTC) (Swaziland)	Universal Service Obligation belongs to the policy maker. This is only defined in the New ICT Bill which is being debated in Parliament.
AHCIET (Colombia)	<ul style="list-style-type: none"> <li>– By a combination of investments to implement the plan, combining public and private funding to develop broadband.</li> <li>– Planned investment in the creation of technocentres to improve connectivity of local authorities and improve terminals.</li> <li>– Provision of subsidies for broadband consumption by the general public.</li> </ul>
Autorité de Régulation de la Poste et des Télécommunications (Dem. Rep. of the Congo)	In the draft law, it is considered an obligation in the same way as universal service and universal access.
Cable Bahamas Limited (Bahamas)	The overarching goal is set out in the policy and then more define requirements are set out in the legislation.
Organismo Supervisor de Inversión Privada en Telecomunicaciones (Peru)	<p>(Based on the Law awarding the Telecommunications Investment Fund (FITEL) legal personality under public law, assigned to the Transport and Communications sector – Law No. 28900 and Article 7 of Supreme Decree No. 024–2008–MTC approving the General Regulatory Framework for promotion of the development of public telecommunication services in rural areas and places of preferential social interest).</p> <p>Universal Access has been defined in Peru as access within the national territory to a set of basic telecommunication services with the capacity to transmit voice and data, such as fixed telephony, mobile services, long distance, local carrier, Internet, as well as the use of broadband to provide such services. The handling of free calls to emergency services is also considered to be a basic public telecommunication service. Universal access also includes training in the use of information and communication technologies (based on Article 7 of Supreme Decree No. 024–2008–MTC approving the General Regulatory Framework for promotion of the development of public telecommunication services in rural areas and places of preferential social interest).</p>
Ministry of Communications and Informatization (Belarus)	Council of Ministers Order No. 889 of 15 July 2006 concerning universal services.
Agência Nacional de Telecomunicações – ANATEL (Brazil)	<p>Act 9.472/1997 defines that universal service obligations are established by Anatel for services in the public regime.</p> <p>The obligation is defined by the Universalization Goals General Plan (PGMU) for the PSTN communications, that was recently revised and updated by Act 7.512, of 30 of June of 2011.</p> <p>These goals are periodically revised.</p>
Ministry of Information and Communication Technology (Mauritius)	It is defined under the Information and Communication Technologies (Universal Service Fund) Regulations 2008 under section 21 and 48 of the ICT Act 2001 (as amended) and the contract between designated USPs (Universal Service Providers) and the regulator.
Ministry of Internal Affairs and Communications (Japan)	The obligation of NTT East and NTT West under the law to provide telephones (basic fee), fibre IP phones corresponding to telephones, public telephones of category one (public telephones installed based on the MIC criteria), or emergency numbers (No.110, No.118, No. 119), which are essential communications service for the people's daily lives, universally in Japan.
Ministry of Transport of the Republic of Latvia (Latvia)	Universal Telecommunication service/access obligation is defined in accordance with the Regulator (Public Utilities Commission) provisions.

Oman Telecommunications Regulatory Authority (TRA) (Oman)	In the course to achieve the economic and social objectives of the telecommunications sector and after presentation for the council of ministers, shall decide the following: 1. to expand the telecommunications services and networks in defined areas according to geographical location or number of inhabitants and to establish public telecommunications centers including payphones in these areas 2. to specify the basic public telecommunications services which the licensee is obliged to provide to any requesting beneficiary at a reasonable price as decided by the Authority in the service area. 3. to provide maritime telecommunications services 4. to provide telecommunications services to persons with special needs
Rwanda Utilities Regulatory Authority (RURA) (Rwanda)	Operator have rollout plan include in license obligations provided to operators Universal Access for subsidising connectivity to make it affordable to rural and remote area.
ICP – Autoridade Nacional de Comunicações (ANACOM) (Portugal)	There is a USO generic obligation – although not specifically to rural and remote areas but to all the country – to provide telecommunication services (telephony and narrowband internet services), according with the Directive 2002/22/EC of the European Parliament and of the Council of 7 March 2002 on universal service and users' rights relating to electronic communications networks and services (Universal Service Directive).
Comisión Nacional de Comunicaciones (CNC) (Argentina)	Decree 558/2008 establishes SECTION 2. – UNIVERSAL SERVICE. The set of services and programs, time-varying, defined by the national, aimed at the general population with a certain quality at affordable prices, which it must have access, regardless of their geographical location and conditions social, economic and related to physical disabilities. To do the ratings of the services and programs, the enforcement authority may consider the totality of telecommunications services, regardless technologies. The Enforcement Authority may modify, adapt and integrate services and programs, according to the needs of the population required. Without prejudice to the services and programs that define the implementing authority under the present rules, Basic Telephone Service Licensees (LSB) are required to expand the fixed telephone network within sixty (60) months, the total geographical area of their respective regions, as of the effective date hereof. The Enforcement Authority shall determine in each case whether the LSB will be compensated with funds from the Universal Service Trust Fund.

**11 Is there a provision of Universal Service Fund or similar type of fund for the development of Telecommunications/ICTs/Broadband in rural and remote areas?**

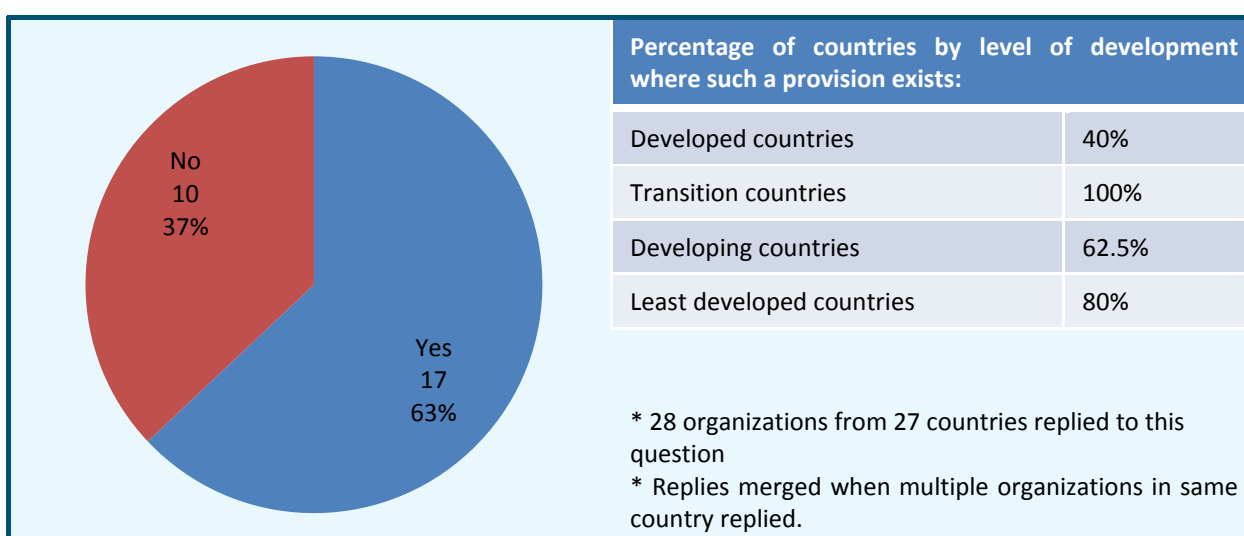



## 12 If such a provision exists, how are the funds collected?

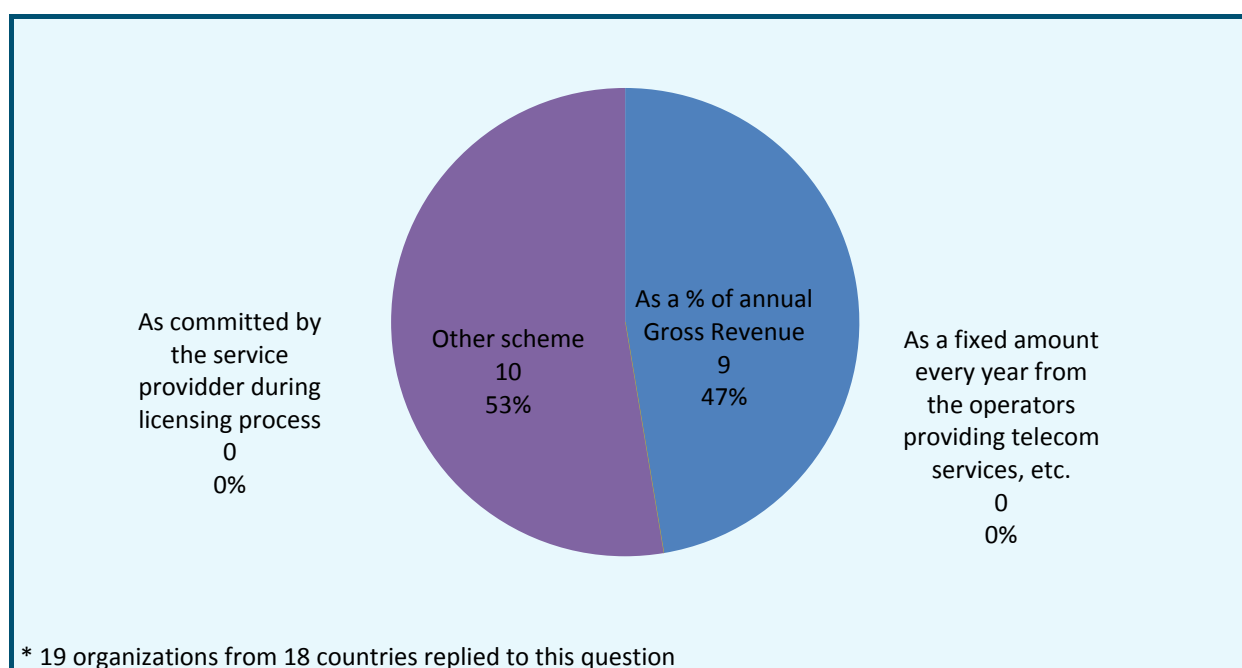

## If "Other scheme" was selected, please specify:

ABI Research (United States) (United Kingdom)	Combination of government spending, european regional development fund and ISP contributions, including some derived from the licensing fees perceived by the BBC.
Telecommunication & Radiocommunication Regulator (TRR) (Vanuatu)	As a % of Annual Net Revenue in the basis of the estimate cost of the UA Project.
Syrian Telecommunication Regulatory Authority (SyTRA) (Syrian Arab Republic)	Not yet determined.
AHCIET (Colombia)	Combination of public investment by the State, via funds similar to those intended for universal service, and investment by private operators, an example of public-private financing.
Autorité de Régulation de la Poste et des Télécommunications (Dem. Rep. of the Congo)	2% of pre-tax turnover.
Ministry of Communications and Informatization (Belarus)	A universal services reserve is funded by compulsory contributions from telecommunication operators to the tune of 1 per cent of telecommunication service revenues.
Oman Telecommunications Regulatory Authority (TRA) (Oman)	the government intend to establish a new company "Oman Broadband company " to provide BB to all areas ,including the remote areas
Cable Bahamas Limited (Bahamas)	An application has to be made for reimbursement and then it is collected from operators. The scheme is still being developed.

<p>Organismo Supervisor de Inversión Privada en Telecomunicaciones (Peru)</p>	<p>(Based on the Law awarding the Telecommunications Investment Fund (FITEL) legal personality under public law, assigned to the Transport and Communications sector – Law No. 28900, Consolidated Amended Text of the Telecommunications Law (approved by Supreme Decree No. 013–93–TCC of 6 May 1993 and Law for the Promotion of Broadband and Construction of the National Fibre Optic Backbone Network – Law No. 29904.)</p> <p>The Telecommunications Investment Fund (FITEL) has been set up for the provision of universal access to telecommunications. It was established by the Consolidated Amended Text of the Telecommunications Law.</p> <p>FITEL has the following resources:</p> <ol style="list-style-type: none"> <li>1 One per cent (1%) of the income invoiced and collected by carrier service operators in general, public end services, public end services in the public cable broadcasting distribution service and the public value-added service (Internet access), as referred to by Article 12 of the Consolidated Amended Text of the Telecommunications Law, approved by Supreme Decree No. 013–93–TCC.</li> <li>2 A percentage of the fee collected for use of the radio frequency spectrum for public telecommunication services (this percentage shall in no case be less than 20 per cent of such collection), as referred to by Article 60 of the Consolidated Amended Text of the Telecommunications Law, approved by Supreme Decree No. 013–93–TCC, with the percentage being set by supreme decree.</li> <li>3 The resources transferred by the public treasury.</li> <li>4 The financial income generated by the FITEL resources.</li> <li>5 The contributions, allocations, donations or transfers made by whatever token, from national or foreign natural or legal persons.</li> <li>6 Other forms established by supreme decree.</li> <li>7 Resources from counterfactual sources obtained by the State pursuant to the terms and conditions agreed to in the public telecommunication services licensing contracts. These resources are distinct from those deriving from the concepts foreseen in the General Telecommunications Law, and shall be used solely to finance the telecommunication transport networks. (Based on Article 13 of the Regulations of Law No. 28900, awarding the Telecommunications Investment Fund (FITEL) legal personality under public law, and the Additional Final Provisions of Law No. 29904 – Law for the Promotion of Broadband and Construction of the National Fibre Optic Backbone Network.)</li> </ol>
<p>Ministry of Information and Communication Technology (Mauritius)</p>	<p>As per Regulation 3 of GN 206 of 2008 (amended by GN 207 of 2010)</p> <ol style="list-style-type: none"> <li>(a) For the purposes of section 21(2) of the Act, the annual contribution payable by a public operator into the Fund shall be paid in monthly instalments.</li> <li>(b) Every monthly instalment payable under paragraph (a) shall consist of –             <ol style="list-style-type: none"> <li>(i) 5 per cent of the gross revenue which the public operator generates from the provision of international roaming service for that month:</li> <li>(ii) 0.025 US Dollar on every minute of international calls which the public operator terminates in Mauritius that month, and shall be paid no later than 60 days after the end of that month.</li> </ol> </li> </ol>
<p>Comisión Nacional de Comunicaciones (CNC) (Argentina)</p>	<p>The telecom service providers in the country, must provide one percent (1%) of all revenue earned from the provision of telecommunications services, net of taxes and duties levied.</p>

**13 Who is responsible for the disbursement in question 12?**

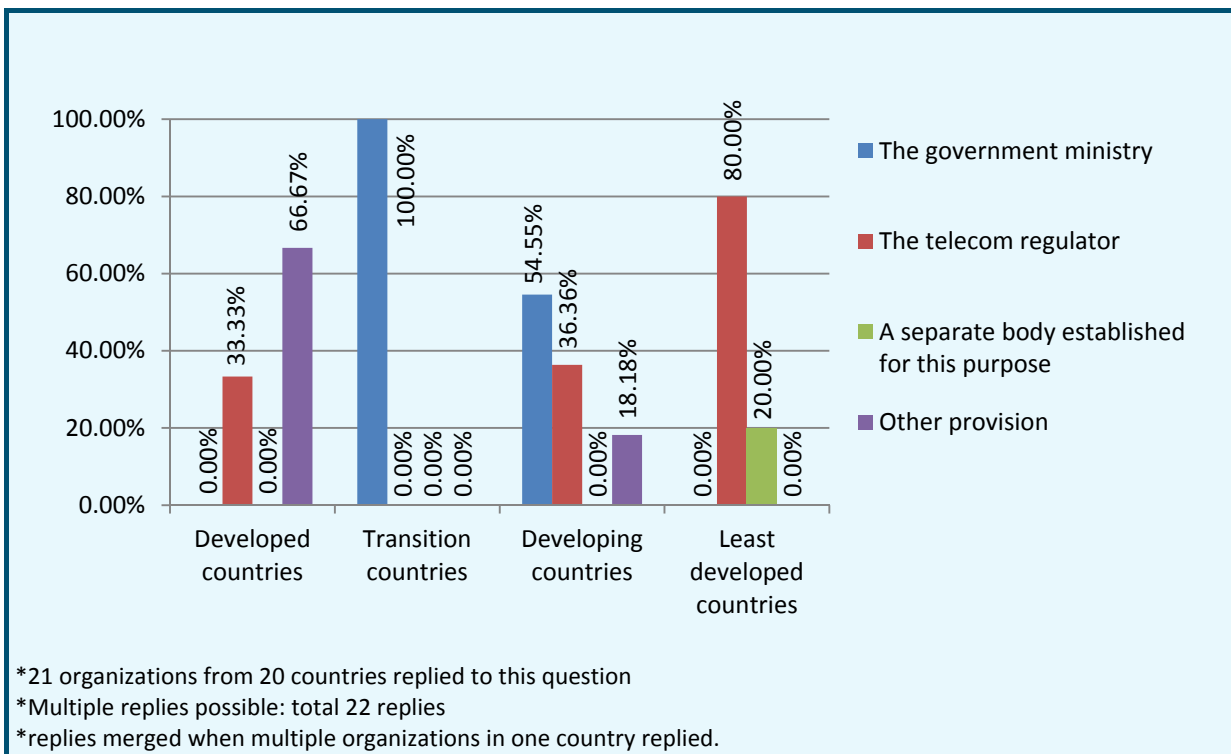
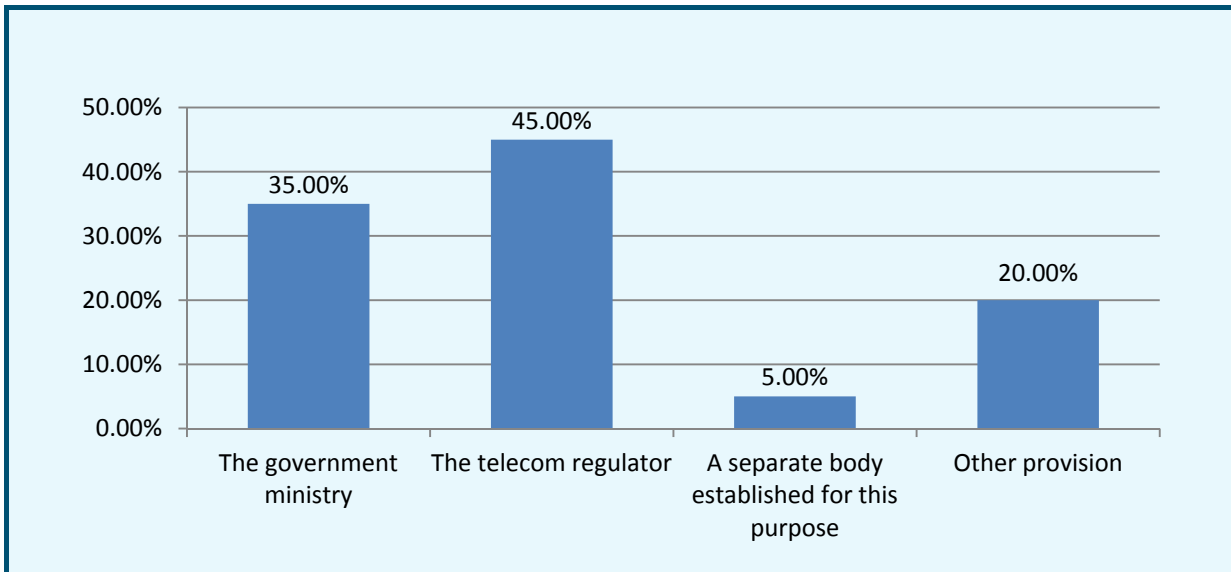

**If “Other provision” was selected, please specify:**

Servei de Telecomunicacions d'Andorra (STA) (Andorra)	Servei de Telecomunicacions d'Andorra
ABI Research (United States) (United Kingdom)	The government allocates the funds to local councils, who are helped by various devolved administrations, to manage bids and spend the funds.
Syrian Telecommunication Regulatory Authority (SyTRA) (Syrian Arab Republic)	The universal service fund will be created by presidential decree in which all details (funding, costs / payment management, etc.) will be specified.
Organismo Supervisor de Inversión Privada en Telecomunicaciones (Peru)	FITEL's budget comes under the portfolio of the Ministry of Transport and Communications, in the Transport and Communications sector (based on Ministerial Resolution No. 879–2011–MTC/01).
Comisión Nacional de Comunicaciones (CNC) (Argentina)	The investment contributions are administered through the Universal Service Trust, whose trustee is chosen by a selection process that ensures the audience, to the satisfaction of the Ministry of Communications.

**14 Who is responsible for managing those funds?**

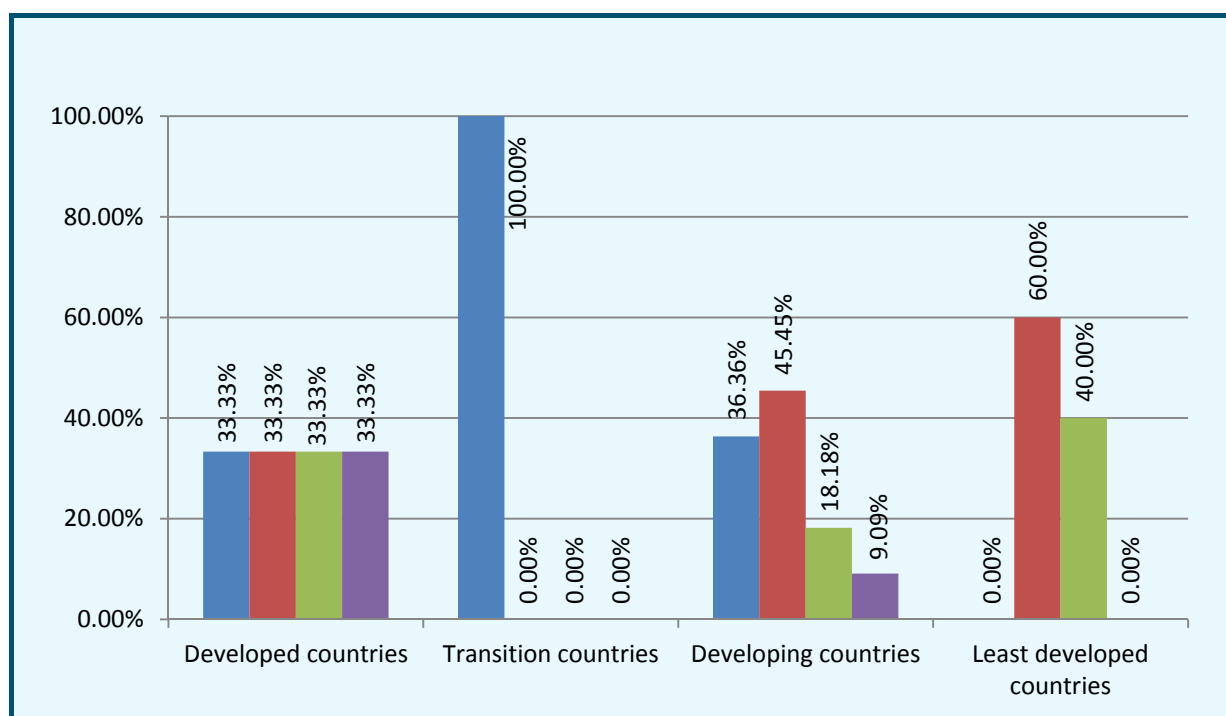

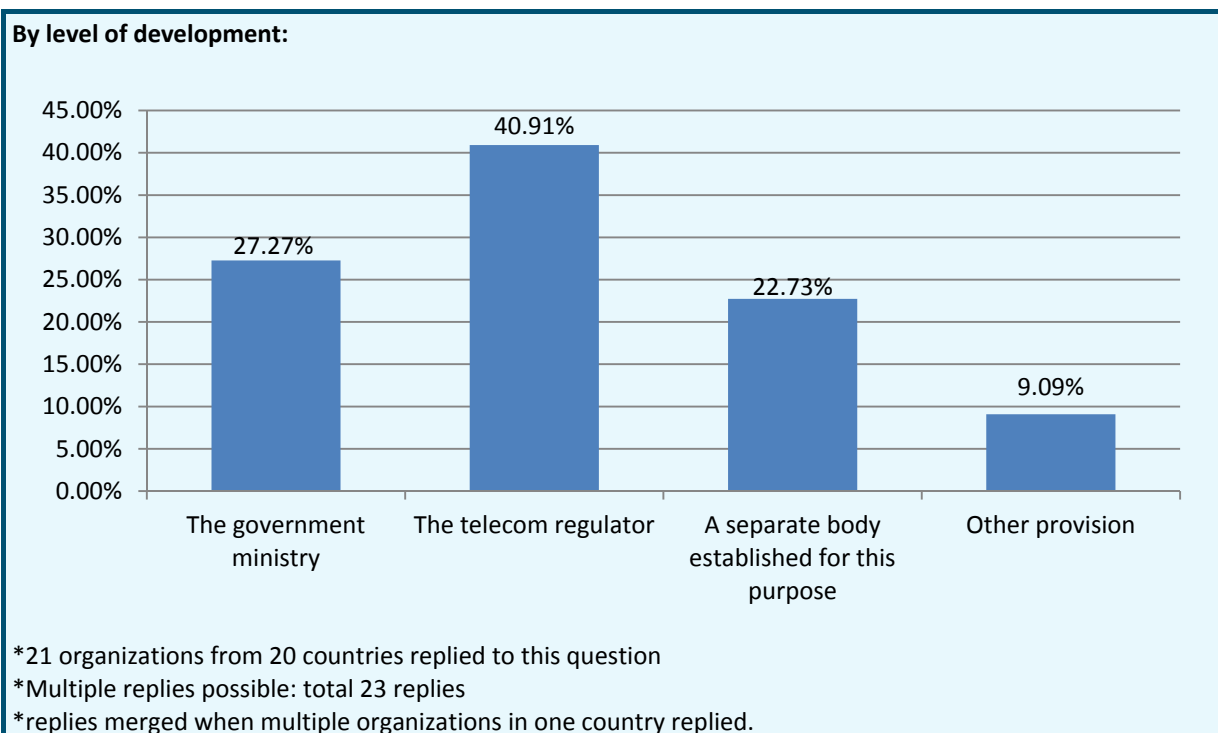

ABI Research (United States) (United Kingdom)	Broadband Delivery UK (BDUK), a unit within DCMS, is responsible for managing the Government's broadband funding. Individual projects are the responsibility of local authorities and the Devolved Administrations, as set out in BDUK's delivery model.
Servei de Telecomunicacions d'Andorra (STA) (Andorra)	Servei de Telecomunicacions d'Andorra
Organismo Supervisor de Inversión Privada en Telecomunicaciones (Peru)	Article 8 of Law No. 28900 provides that FITEL is administered by a directorate chaired by the Minister of Transport and Communications and which includes the Minister of the Economy and Finances and the Chairman of the Governing Council of the Supervisory Authority for Private Investment in Telecommunications – OSIPTEL. Moreover, pursuant to Article 7 of the Administrative and Operational Regulations of the Telecommunications Investment Fund (FITEL), FITEL's Governing Council is responsible for establishing FITEL's general policy and administrative policy.
Comisión Nacional de Comunicaciones (CNC) (Argentina)	There is a Technical Committee composed of seven members: a) two appointed by the Minister of Communications. b) one, the National Communications Commission. c) three, by providers (two appointed by the Licensees and the third by the other providers, excluding independent operators) and one Independent Operators. Its main function is to receive from the Enforcement Authority's payroll and issued programs or services on technical, economic and financing of them, the latter, according to the financial capacity of the Trust Fund.

**15 What kind of economic model is being employed for the development of Telecommunications/ICTs/Broadband in rural and remote areas?**

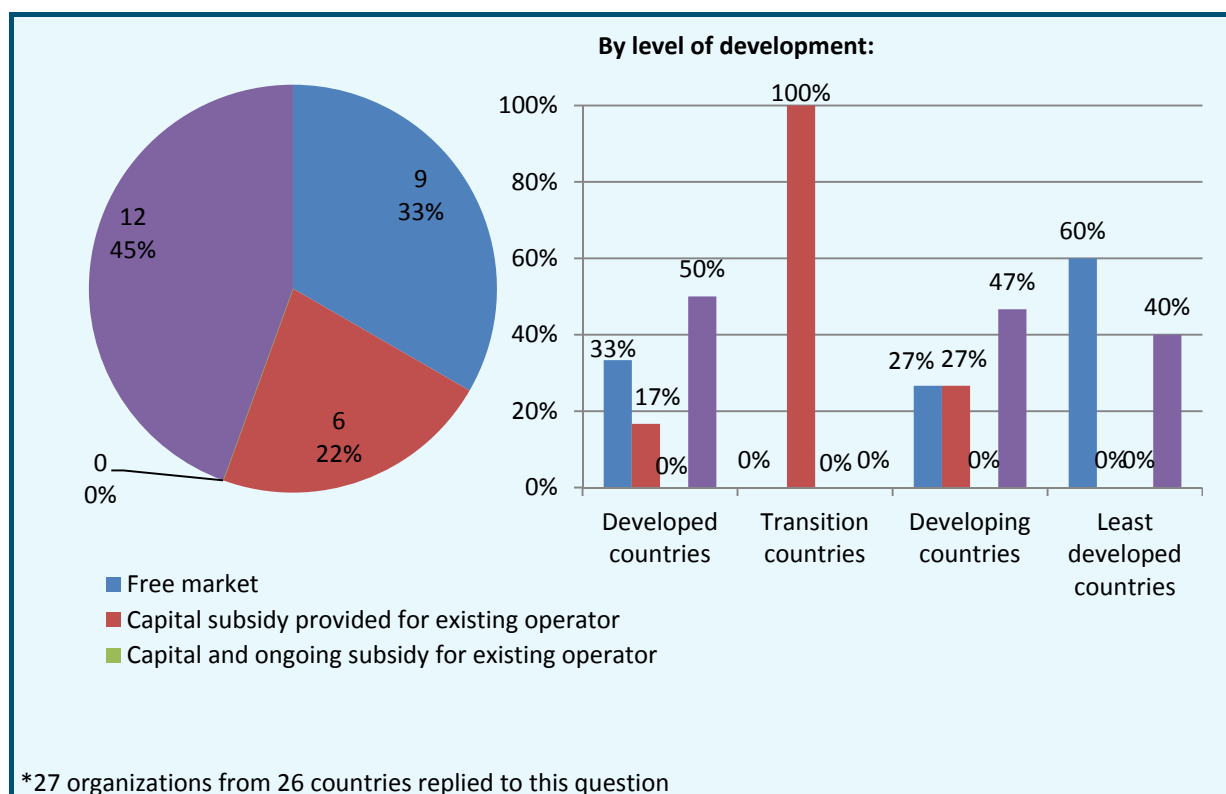

**If “other” was selected, please specify:**

ABI Research (United States) (United Kingdom)	Free market underpinned by capital subsidy for local councils
Telecommunications Regulatory Authority (Lebanon)	See 4
Syrian Telecommunication Regulatory Authority (SyTRA) (Syrian Arab Republic)	Not currently in existence.
Telecommunication & Radiocommunication Regulator (TRR) (Vanuatu)	To date the govt has not set a specific project, but free market is taking effect, rolling out up to 90% voice and data access. Data access is at 90% for GPRS, Edge Access, Broadband, 3G, Wifi, and wimax provides for 20%.
Comisión Nacional de Telecomunicaciones (CONATEL) (Paraguay)	Biddings take place in order to subsidize the expansion of the infrastructure. The bidders are existing operators concerned by the infrastructure to be subsidized.
Nepal Telecommunications Authority (NTA) (Nepal (Republic of))	We are following all the above mentioned options: Free market, capital subsidy provided for existing operator, capital and ongoing subsidy for existing operator
AHCIET (Colombia)	Public–private combination. The operator and MINTIC contribute to the ICT programme. In specific terms, the State through the Ministry of Technology has made an initial investment of 228 million dollars and private operators have invested 439 million.

Organismo Supervisor de Inversión Privada en Telecomunicaciones (Peru)	There is one model according to which the operator brings the service to rural areas or places of preferential social interest as part of certain obligations stipulated in the operator's licensing contract; and there is another model involving the subsidization of telecommunication projects in rural areas or places of preferential social interest. In this second model, FITEL is responsible for managing such projects, and finances the capital and/or operating costs.
Agência Nacional de Telecomunicações – ANATEL (Brazil)	Universalization Goals General Plan (PGMU) defines obligations for rural and remote areas. Also, auctions for radiofrequency are establishing obligations as well for anyone who wins the auctions. Capital subsidy provided for existing operators are also used, since auction prices are defined considering the cost of the obligation.
Ministry of Transport of the Republic of Latvia (Latvia)	State aid programme for private operator
Rwanda Utilities Regulatory Authority (RURA) (Rwanda)	Free market and open competition among operators to deliver services all over the country. Subsidy to Operator using Universal Access Fund for connectivity and coverage in remote and rural area. Government Optic fiber network backbone covering the whole country for broadband services
ICP – Autoridade Nacional de Comunicações (ANACOM) (Portugal)	Within the scope of the national Strategic Reference Framework (QREN), public investments made on high throughput broadband infrastructure in areas where market agents do not find the needed operating conditions to offer these services, namely concerning demographic density, might be eligible for support. The above mentioned five projects for the construction, installation, financing, operation and maintenance of NGA in rural areas are co-financed – the tenderers submitting winning bids were DStelecom (Alentejo and Algarve Zone and North Zone) and Viatel (in the Central zone and in the areas of the autonomous regions), whereas the signing of the contracts was subject to approval by the European Commission (and according with the European
Cable Bahamas Limited (Bahamas)	Operator has to provide the service and then request reimbursement for the unavoidable costs.
Comisión Nacional de Comunicaciones (CNC) (Argentina)	The projects are funded by the Universal Service Fund. The deployment of fiber optic (Fibre Federal Network) is funded by state ARSAT SA

16 What kind of business model is being developed?

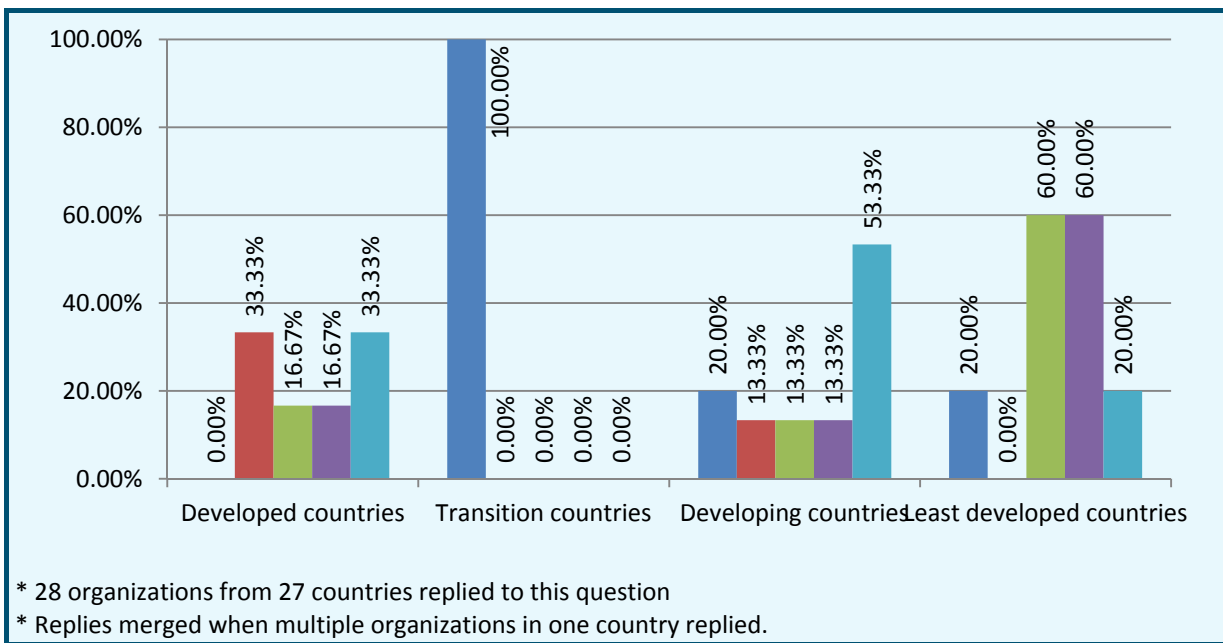
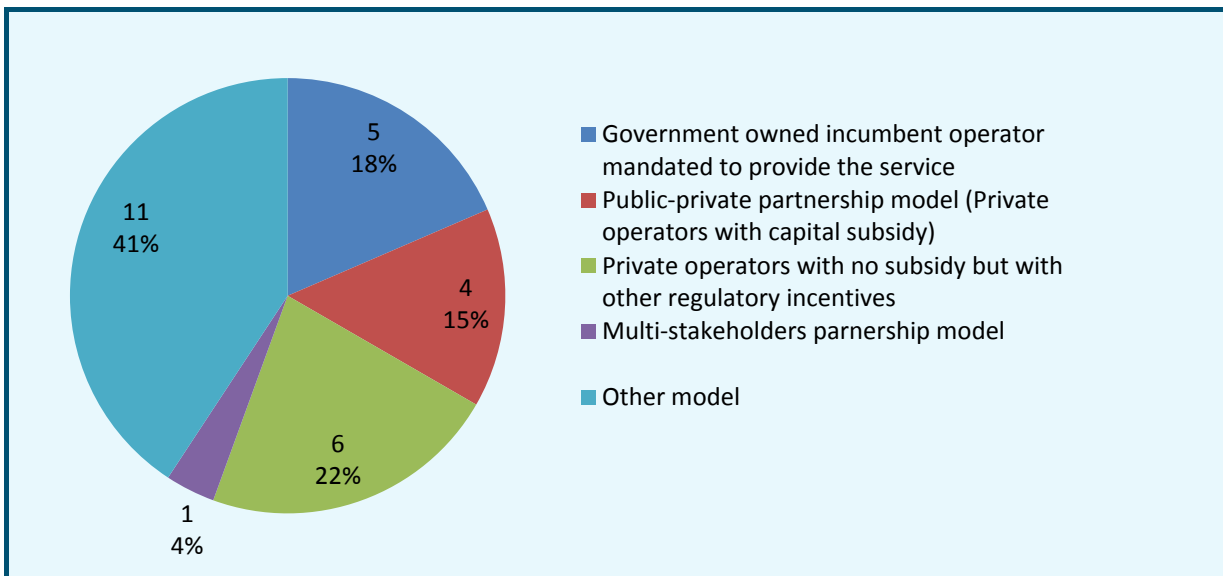



**If “other model” was selected, please specify:**

Cellular Operators Association of India (COAI) (India)	The different schemes as listed above in the 6 Streams have different models. Some have Capex subsidy mostly to the Government owned Public Sector undertaking BSNL. For the scheme for rural telephones it is a combination of CAPEX+OPEX for PSU and Private service providers.  In the recent case of the OFC for panchayats, the Government has floated a new company by the name of " Bharat Broadband Network Limited – BBNL" . This has funding from the USO Fund and partnership with the government owned public undertakings – BSNL, RailTel, Powergrid Corporation of India. These companies will pool in existing resources of OFC and will lay "incremental OFC" to areas where new OFC is required for extension till the panchayat office. The Bandwidth will be provided on open access to seekers.
Servei de Telecomunicacions d'Andorra (STA) (Andorra)	The Operator (which is government-owned) provides the service.
Comisión Nacional de Telecomunicaciones (CONATEL) (Paraguay)	Conatel provides the subsidy, but the infrastructure remains the property of the operator who has been awarded the contract.
Nepal Telecommunications Authority (NTA) (Nepal (Republic of))	We are adopting all of the above business models depending on the case: (1) Government owned incumbent operator mandated to provide the service (2) Public-Private Partnership model (Private operators with capital subsidy) (3) Private Operators with no subsidy but with other regulatory incentives (4) Multi-stakeholders partnership model
Organismo Supervisor de Inversión Privada en Telecomunicaciones (Peru)	On one hand there is the case of companies operating in rural areas or places of preferential social interest without government subsidies; and on the other, the Public Private Partnership model, wherein the State finances the projects or part thereof, with project execution by private players.
Agência Nacional de Telecomunicações – ANATEL (Brazil)	Both the Government owned incumbent operator mandated to provide the service and private operators with some subsidy are used.
Ministry of Transport of the Republic of Latvia (Latvia)	Government owned infrastructure operator with EU funds support.
Office of the President, Department of Information Communication Technology (Seychelles)	Cost-Based basis
Oman Telecommunications Regulatory Authority (TRA) (Oman)	Government BB Company will be providing the passive infrastructure for the telecom operators in the remote areas
Cable Bahamas Limited (Bahamas)	Government owned incumbent operator as well as a monopoly public company required to provide services.
Comisión Nacional de Comunicaciones (CNC) (Argentina)	The state company has ownership ARSAT network.

**17 How is major backbone infrastructure being developed in rural and remote areas?**

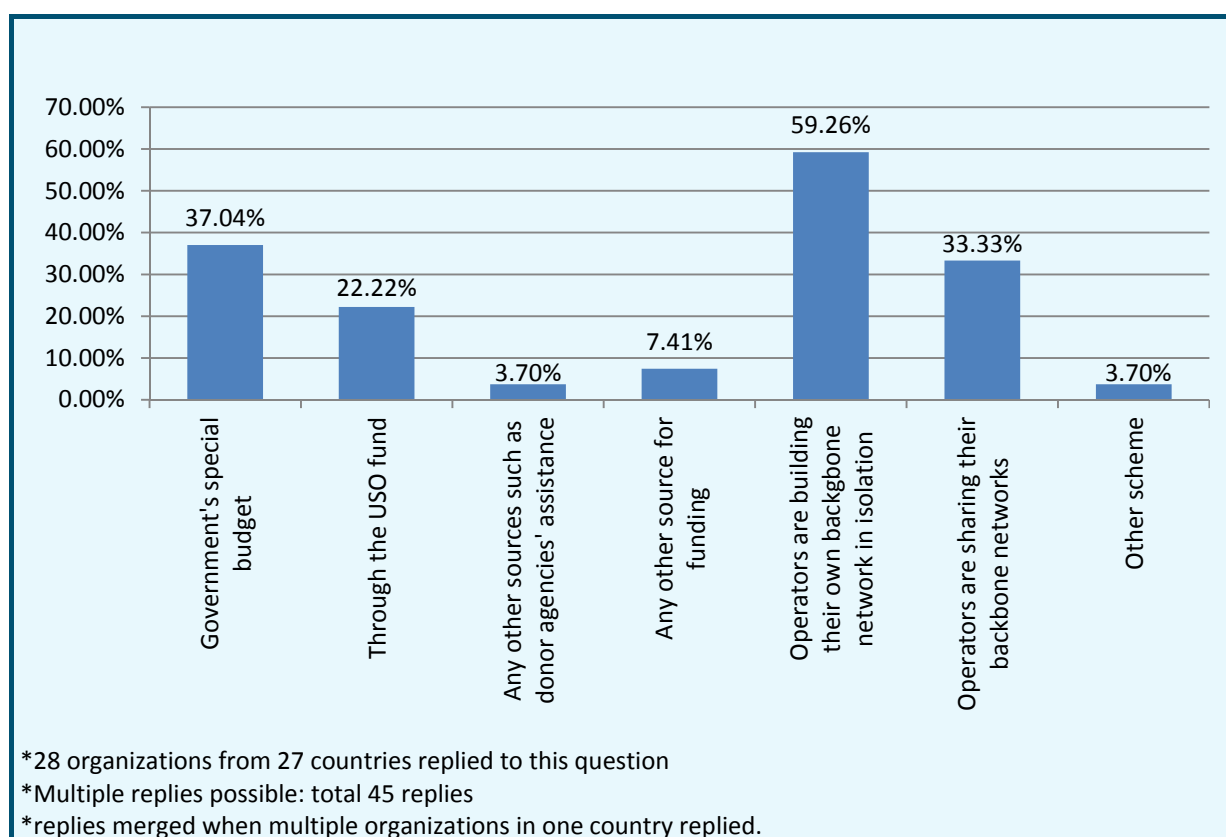

**If “any other source” for funding was selected, please elaborate:**

Servei de Telecomunicacions d'Andorra (STA) (Andorra)	The Operator has deployed the network.
Ministry of Internal Affairs and Communications (Japan)	Guarantee for a debt
ICP – Autoridade Nacional de Comunicações (ANACOM) (Portugal)	Government and EU funds. See answer to Q.15. Note: The incumbent operator (currently, a private operator) has developed its own national backbone, also in rural and remote areas (areas where it is the only backbone infra-structure in place).

**If “other scheme” was selected, please specify:**

Cable Bahamas Limited (Bahamas)	There is no national broadband network being funded. Each operator is responsible for building the network out of its funds.
---------------------------------	--

**18 Do you have any specific policy, legal and/or regulatory framework for infrastructure sharing, especially in the rural and remote areas, for example optical fiber cable and BTS/Microwave towers and the related support infrastructures?**

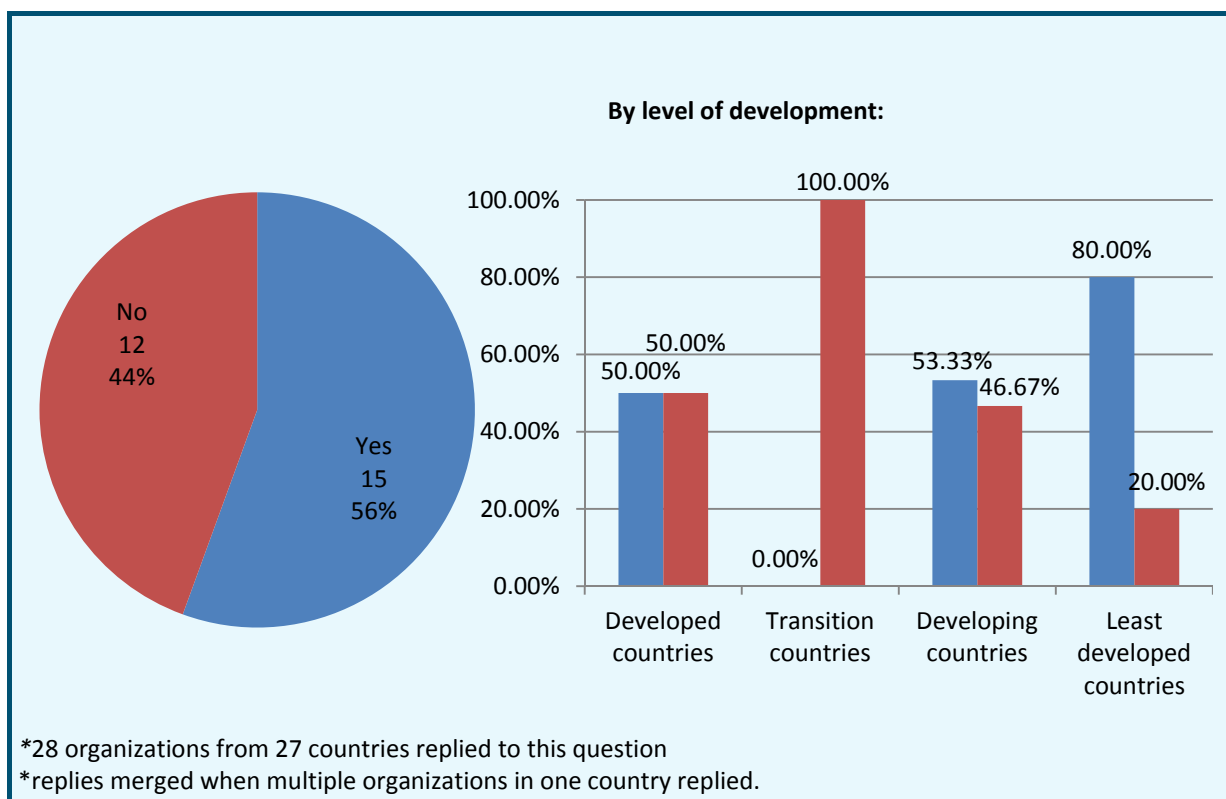

**19 If such a framework exists, who issues such instruments?**

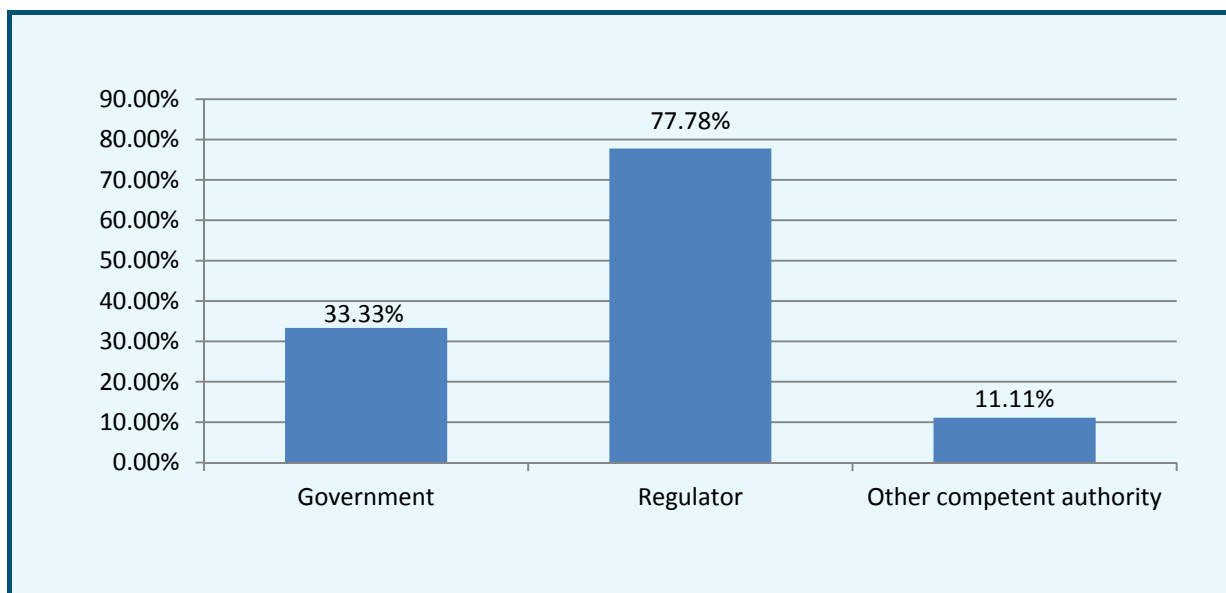

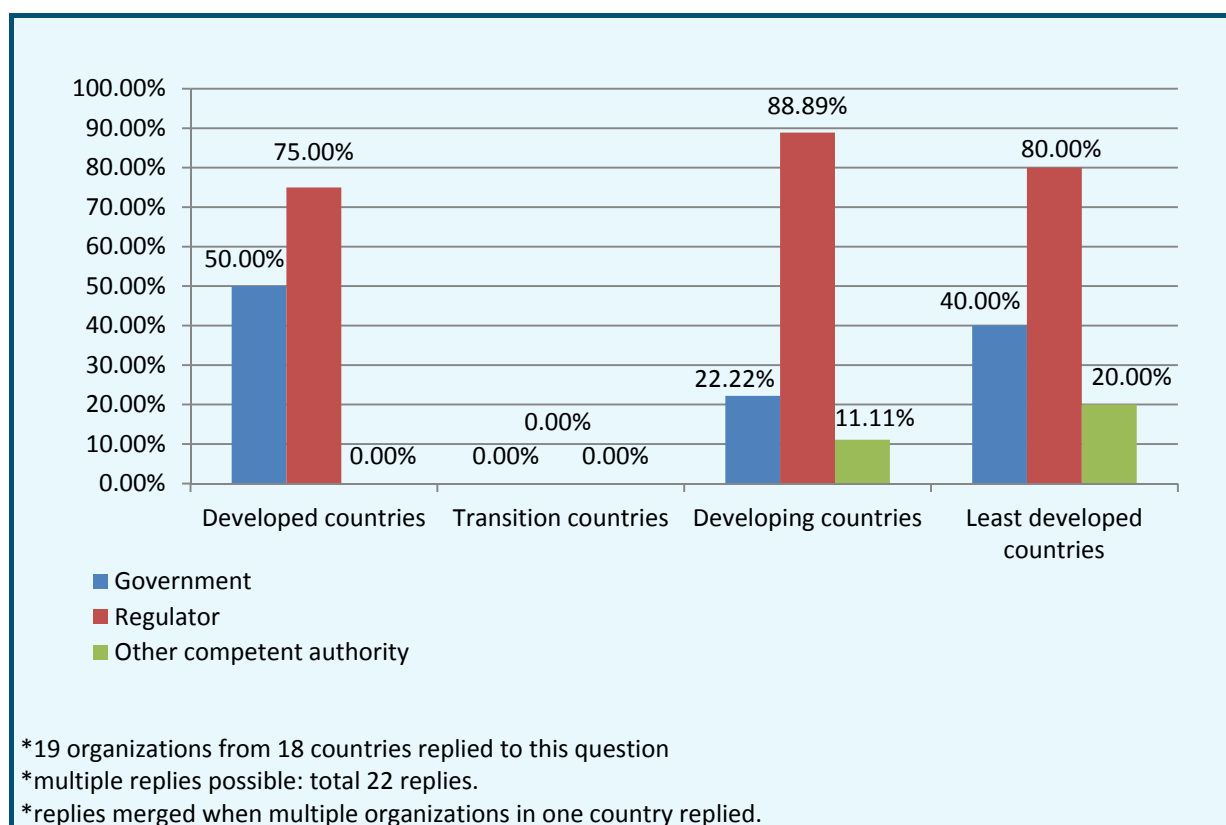

**If “Other competent authority” was selected, please specify:**

ABI Research (United States) (United Kingdom)	Due to Ofcom’s findings that they have significant market power, BT and KCom have regulatory obligations to provide access to their networks and to provide certain wholesale services to third party CPs.
Nepal Telecommunications Authority (NTA) (Nepal (Republic of))	Recently a 13 member special committee has been established for this.
Swaziland Posts and Telecommunications Corporation (SPTC) (Swaziland)	Parliament Act No. 11 of 1983, as amended
ICP – Autoridade Nacional de Comunicações (ANACOM) (Portugal)	<p>Although there is no specific policy for rural and remote areas, the Portuguese Government published in 2009 new legislation on access to passive infrastructure either at the horizontal and vertical levels, that is, access to all ducts and associated infrastructure (from all entities, namely utilities) and also imposing symmetric regulation on the installation and access to in-house wiring (namely fibre).</p> <p>The approval of the Law no. 32/2009, of 9 July, authorized the Government to legislate on the regime of open access (by any operator) to infrastructures suitable for the accommodation of electronic communications networks and to lay down the regime of challenge to measures taken by ICP-ANACOM in the scope of the regime governing the construction, access to and set up of electronic communications networks and infrastructures countrywide.</p> <p>The Decree-Law nr. 123/2009, of 21 May, sets out the general principles, namely the principles of competition, open access, non-discrimination, effectiveness and transparency, concerning the promotion of the construction, set up and access to infrastructures suitable for the accommodation of electronic communications networks – in a technological neutral approach – in property owned by private entities and public bodies across the country and including all areas, namely rural and/or remote.</p> <p>There are also specific sharing/access obligations imposed on the former incumbent operator (e.g., to ducts and poles).</p>

**20 Are there any instances of infrastructure sharing even in the absence of such instruments mentioned in Question 10-3/2?**

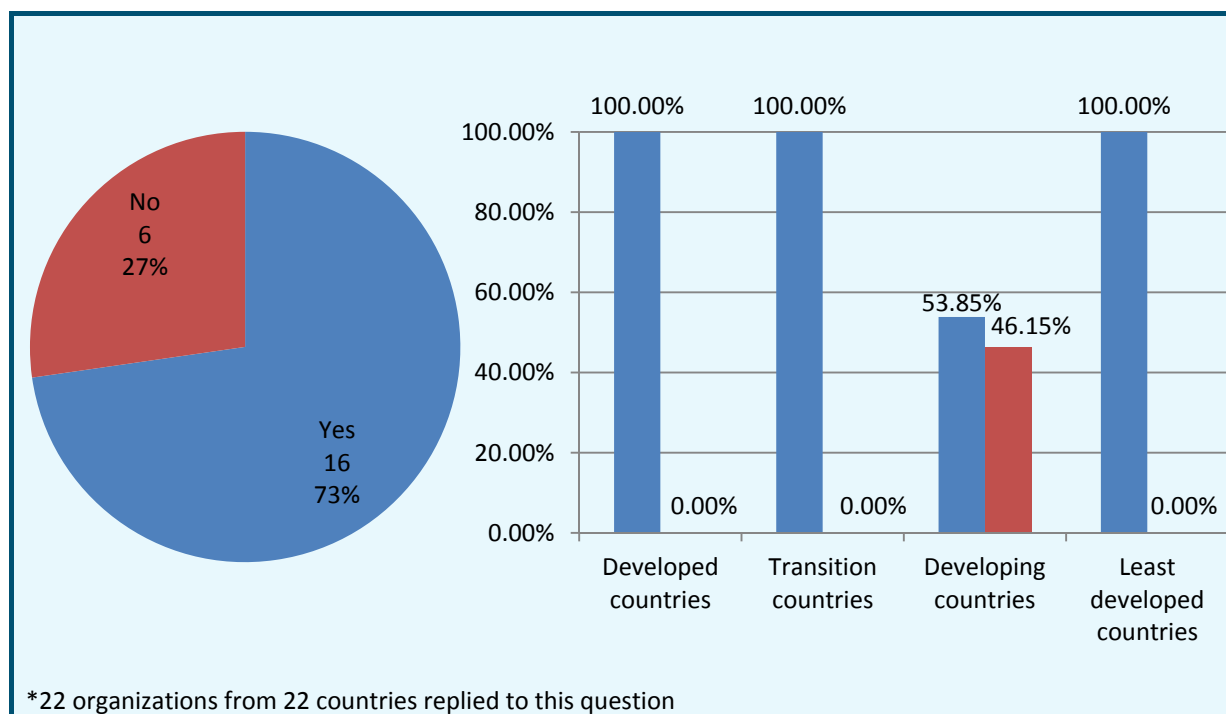

**If yes, please elaborate:**

Cellular Operators Association of India (COAI) (India)	Sharing of passive infrastructure is widely done in India. India has pioneered the sharing of mobile towers and passive infrastructure sharing. We have the largest Infrastructure Provider companies like Indus towers with more than 100,000 towers in their portfolio. The telecom infrastructure providers now provide an Integrated Neutral Host Platform that is used by diverse and often competing operators resulting in the rapid deployment of networks supporting over 600 million mobile subscribers. The new and upcoming technologies such as 3G and BWA services will be highly successful since the easy availability and accessibility of shared towers, a key input for the growth of this sector.
Servei de Telecomunicacions d'Andorra (STA) (Andorra)	Piping with companies in other sectors.
The Egyptian Company for Mobile Services (MOBINIL) (Egypt)	No 'infrastructure sharing' between operators that I know of. The only 'sharing' we do is site sharing. Two or more operators build their shelters and install their antennae in the same physical location. There is no national roaming either.
Ministerio de Tecnologías de la Información y las Comunicaciones (Colombia)	In Colombia, the deployment of the optical fibre backbone has been based on the electrical interconnection system (concerning approximately 70% of the network).
Telecommunication & Radiocommunication Regulator (TRR) (Vanuatu)	Operators enter into infrastructure sharing commercial arrangements.

Syrian Telecommunication Regulatory Authority (SyTRA) (Syrian Arab Republic)	There are currently infrastructure partnership agreements between Syrian Telecom (STE) and the cellphone operators in Syria.
Ministère de la Communication et des Nouvelles Technologies (Niger)	With due respect for the interconnection catalogue in force, we have the following sharing arrangements: <ul style="list-style-type: none"> <li>– Leasing of transmission capacity</li> <li>– Colocation of technical and power equipment</li> <li>– Pylon sharing</li> <li>– Equipment interconnection</li> </ul>
Comisión Nacional de Telecomunicaciones (CONATEL) (Paraguay)	These exist in the case of a private arrangement between operators.
Swaziland Posts and Telecommunications Corporation (SPTC) (Swaziland)	Co-location, Masks for wireless systems and backhauling.
Organismo Supervisor de Inversión Privada en Telecomunicaciones (Peru)	Private agreements for infrastructure sharing currently exist between different telecommunication operators. If operators do not reach agreement on the conditions applicable to infrastructure sharing, the regulator may intervene to establish an agreement between the parties. Regulations also exist regarding access to the electricity, hydrocarbon transport and road infrastructures, in order to allow telecommunication operators to deploy infrastructures, particularly for fibre optic transport networks.
Ministry of Communications and Informatization (Belarus)	Telecommunication operators share infrastructure, including fibre optic communication links and cellular antenna masts, under contractual arrangements.
Oman Telecommunications Regulatory Authority (TRA) (Oman)	National Roaming is applicable and mandated in some remote areas, so both operators can use same BTS
Rwanda Utilities Regulatory Authority (RURA) (Rwanda)	Regulator published infrastructure sharing guidelines that are applied since 2010.
ICP – Autoridade Nacional de Comunicações (ANACOM) (Portugal)	See answer to Q.18 above.
Cable Bahamas Limited (Bahamas)	The requirement to provide television services was achieved through the cable television company provided the signals and the incumbent telephone operator permitting the cable television company to use its towers and central office to accommodate equipment.

**21 Are you planning to bring such guidelines to address the rural challenges?**

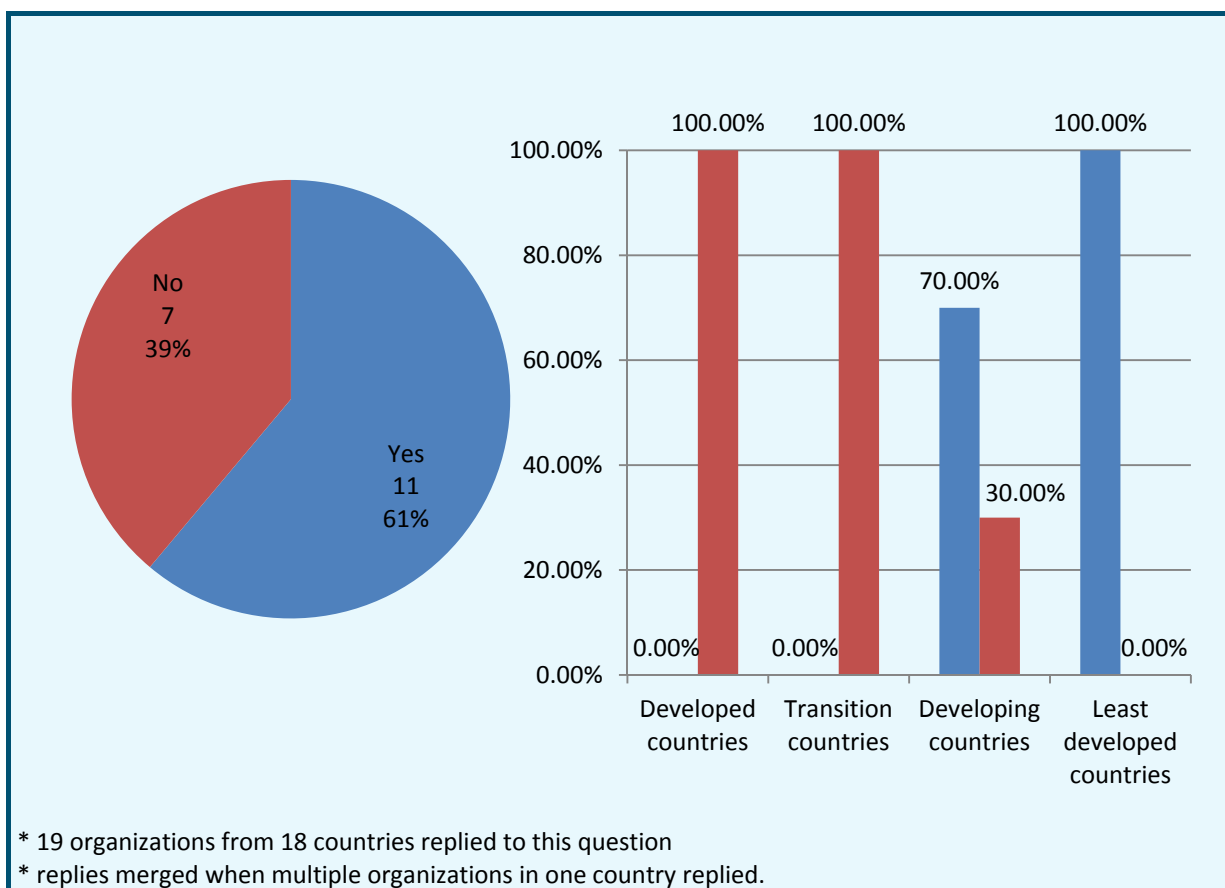

**22 Does your government provide any kind of tax rebate for import of equipments for providing Telecommunications/ICTs/Broadband in rural and remote areas?**

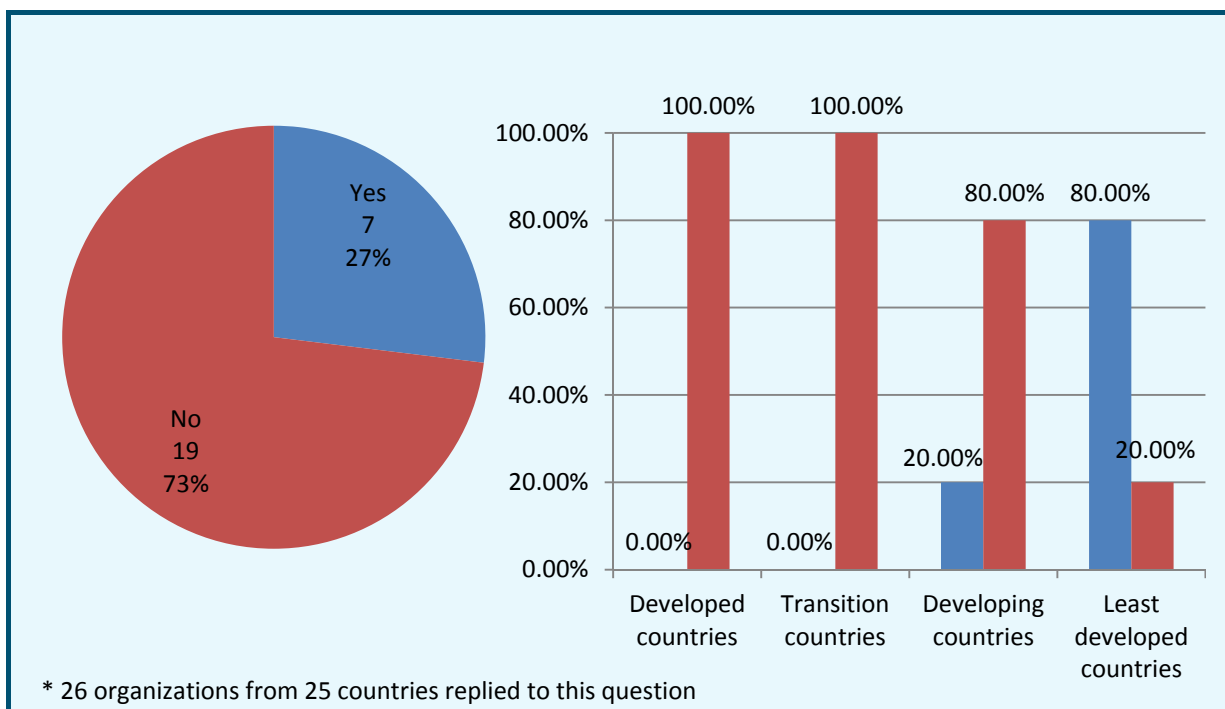

If yes, please provide details, if applicable:

The Egyptian Company for Mobile Services (MOBINIL) (Egypt)	No tax rebates whatsoever.
Telecommunication & Radiocommunication Regulator (TRR) (Vanuatu)	All ICT related equipment such as Laptops, Mobile Phones and Telecommunications infrastructure equipment are exempted from Import VAT and Duty Tax.
Ministère de la Communication et des Nouvelles Technologies (Niger)	The national ICT policy and strategy document foresees incentives for operators wishing to invest in rural areas, in the form of tax benefits (exemption from import taxes and duties on equipment), together with an attractive legal, institutional and economic framework.
Nepal Telecommunications Authority (NTA) (Nepal Republic of)	There is a provision that maximum ceiling of 7 % tax will be levied in telecommunications equipment to be used in rural areas in case the tax is above 5% in the import of telecommunications equipment (excluding few).
AHCIET (Colombia)	– Subsidies for fixed broadband consumption – Tax rebates for IT purchases (especially computers) by the public.
Organismo Supervisor de Inversión Privada en Telecomunicaciones (Peru)	At present, exemption has been given regarding the payment of duties on the import of telecommunication equipment. The tax refund approach is not applied because importers are unable to pay the relevant duties.
Rwanda Utilities Regulatory Authority (RURA) (Rwanda)	All telecommunications/ ICT equipment are taxes exempted

**23 Do the license conditions oblige the Operator/Service provider to provide service in rural and remote areas?**

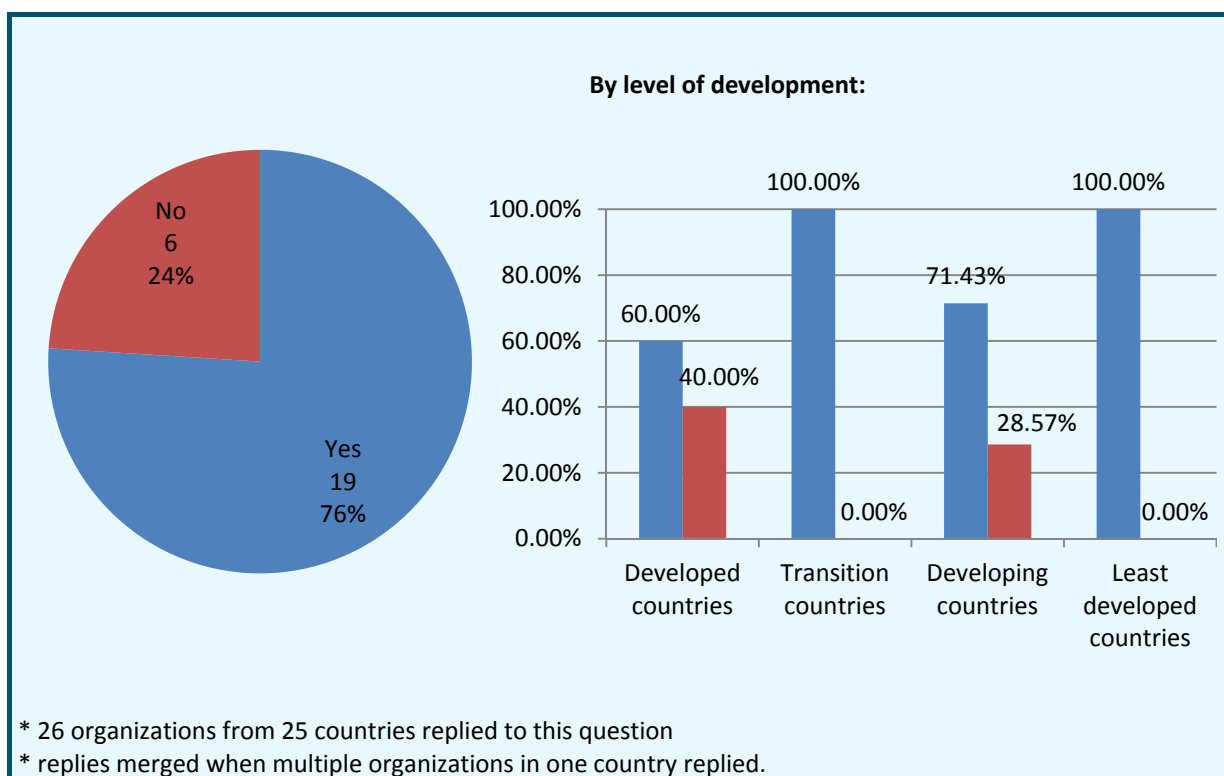



**If yes, please provide further information**

The Egyptian Company for Mobile Services (MOBINIL) (Egypt)	Yes. As mentioned earlier, the license conditions oblige mobile operators to cover at least 98% of population. Since slightly above 50% of the Egyptian population lives in major cities, that leaves the other half living in rural and remote areas which are properly covered.
Ministerio de Tecnologías de la Información y las Comunicaciones (Colombia)	In the case of mobile network operators, the assignment of the license imposes obligations such as cover extension and connectivity services provision to public institutions.
Telecommunication & Radiocommunication Regulator (TRR) (Vanuatu)	New entrant Operator enters into performance guarantee under respective license obligated to roll 85% coverage in the country within two years of operations. To date market dynamics have seen the coverage to be at 90% after 3.5 years of operation.
Ministère de la Communication et des Nouvelles Technologies (Niger)	The license obliges operators/service providers to provide service in rural and remote areas or participate in the financing of universal access. This obligation is annexed to the terms of reference of each operator at the time of acquisition of its license for the establishment and operation of a public telecommunication network.
Syrian Telecommunication Regulatory Authority (SyTRA) (Syrian Arab Republic)	The 2010 telecommunication law obliges operators to provide universal service to rural areas.
Comisión Nacional de Telecomunicaciones (CONATEL) (Paraguay)	Not in current contracts.
Nepal Telecommunications Authority (NTA) (Nepal (Republic of))	Telecommunications Act, 1997 has the provisions that the operators have to invest 15% of their annual investment in rural areas.
CATR of Ministry of Industry and Information Technology (MIIT) (China)	A basic telecommunication operator has to undertake the universal telecommunication service obligations.
Swaziland Posts and Telecommunications Corporation (SPTC) (Swaziland)	Operators are obliged to pay for Universal Service fund of 5% of NOI. Also ensure service availability in remote rural areas, using the cheapest ways possible e.g. payphones.
AHCIET (Colombia)	Universal service obligations and commitments under the "Vive Digital" Plan.
Organismo Supervisor de Inversión Privada en Telecomunicaciones (Peru)	In some cases licences were issued on the condition that the operators provide services in specific rural areas. Nevertheless, not all licences issued are subject to this obligation.
Agência Nacional de Telecomunicações – ANATEL (Brazil)	Universalization Goals General Plan (PGMU) defines obligations for rural and remote areas. Also, auctions for radiofrequency are establishing obligations as well for anyone who wins the auctions. Auctions for 450MHz and 2.5GHz defined obligations to offer data service to rural and remote schools.
Ministry of Internal Affairs and Communications (Japan)	Provision of universal telecommunications service, telephone.

Oman Telecommunications Regulatory Authority (TRA) (Oman)	Yes , but in specific areas , as they have to cover certain percentage of the household in each goveronate
Rwanda Utilities Regulatory Authority (RURA) (Rwanda)	It is part of their license obligation. They have to provide rollout plan when bidding for the operator license.
ICP – Autoridade Nacional de Comunicações (ANACOM) (Portugal)	For example, concerning the licensing of Mobile Network Operators, Digital TV provider, Universal Service provider, etc.
Cable Bahamas Limited (Bahamas)	No, the Communications Act 2009 obliges the Operator/Service provider to provide service in rural and remote areas
Comisión Nacional de Comunicaciones (CNC) (Argentina)	The art. 2 of Decree 558/2008 on Universal Service states that basic telephone service licensees (LSB) are required to expand the fixed telephone network in the total geographical area of their region (North and South)

**24 Do you provide a specific rural/remote area license to Telecommunications/ICTs/Broadband providers in rural and remote areas?**

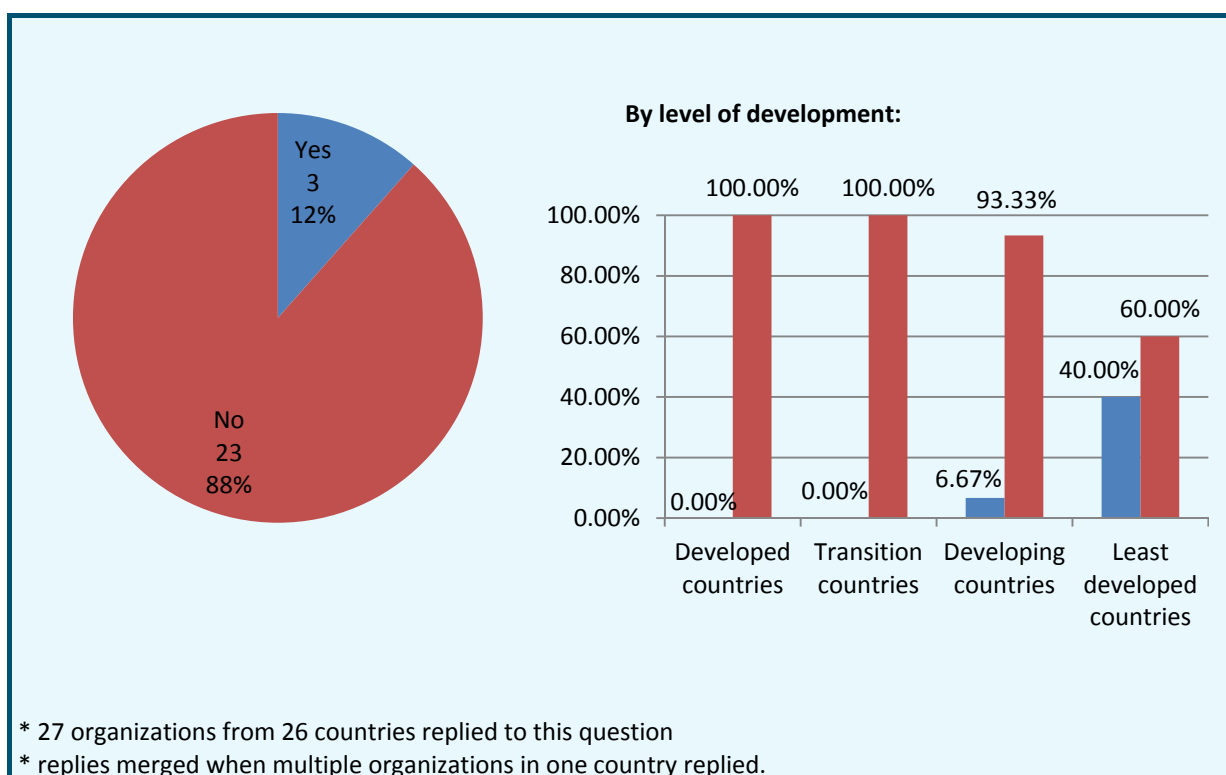

**25** If you answered yes to question 24, are these providers allowed to provide services in urban areas once rural and remote obligations are met?

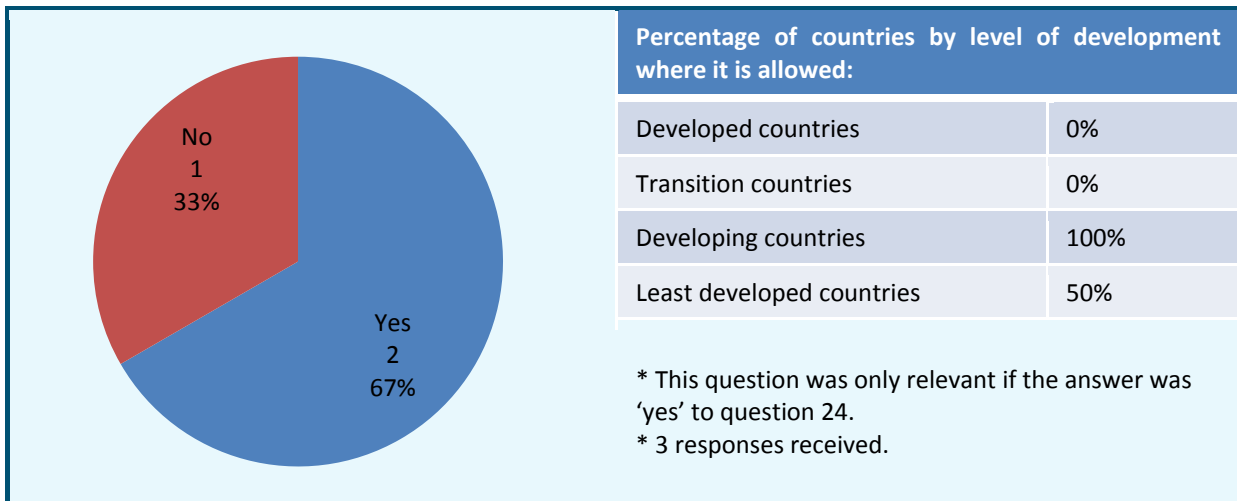

**26** What backhaul/backbone technologies are being used in your country for connecting rural and remote areas? Please tick all that applies

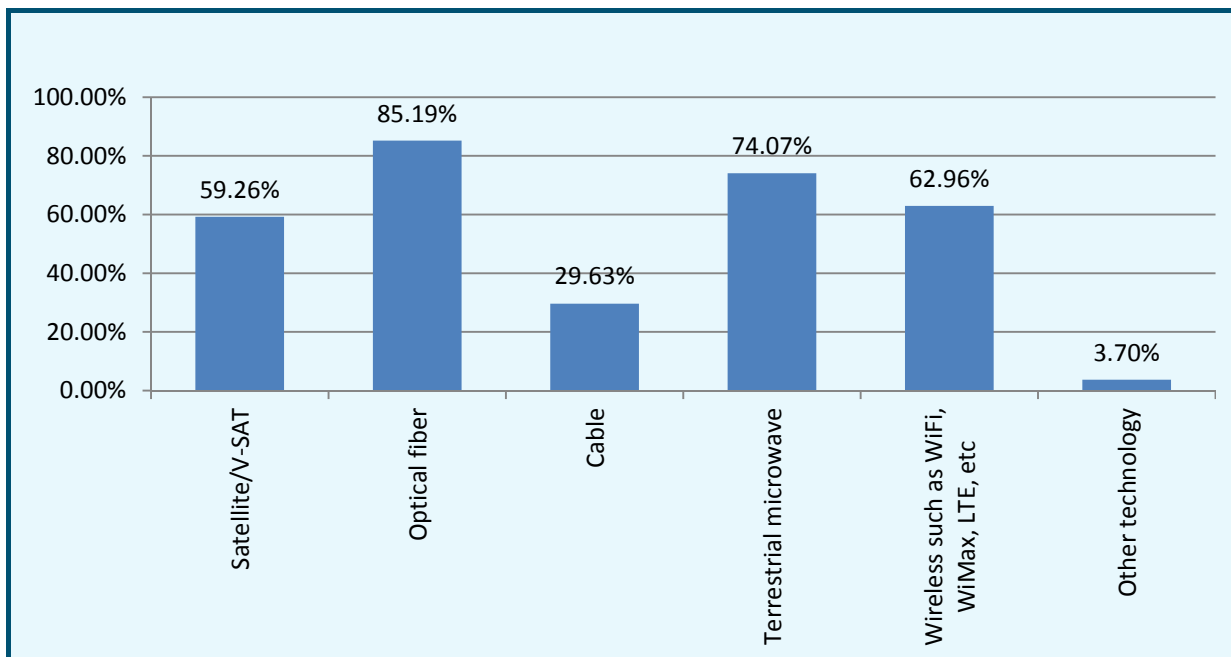

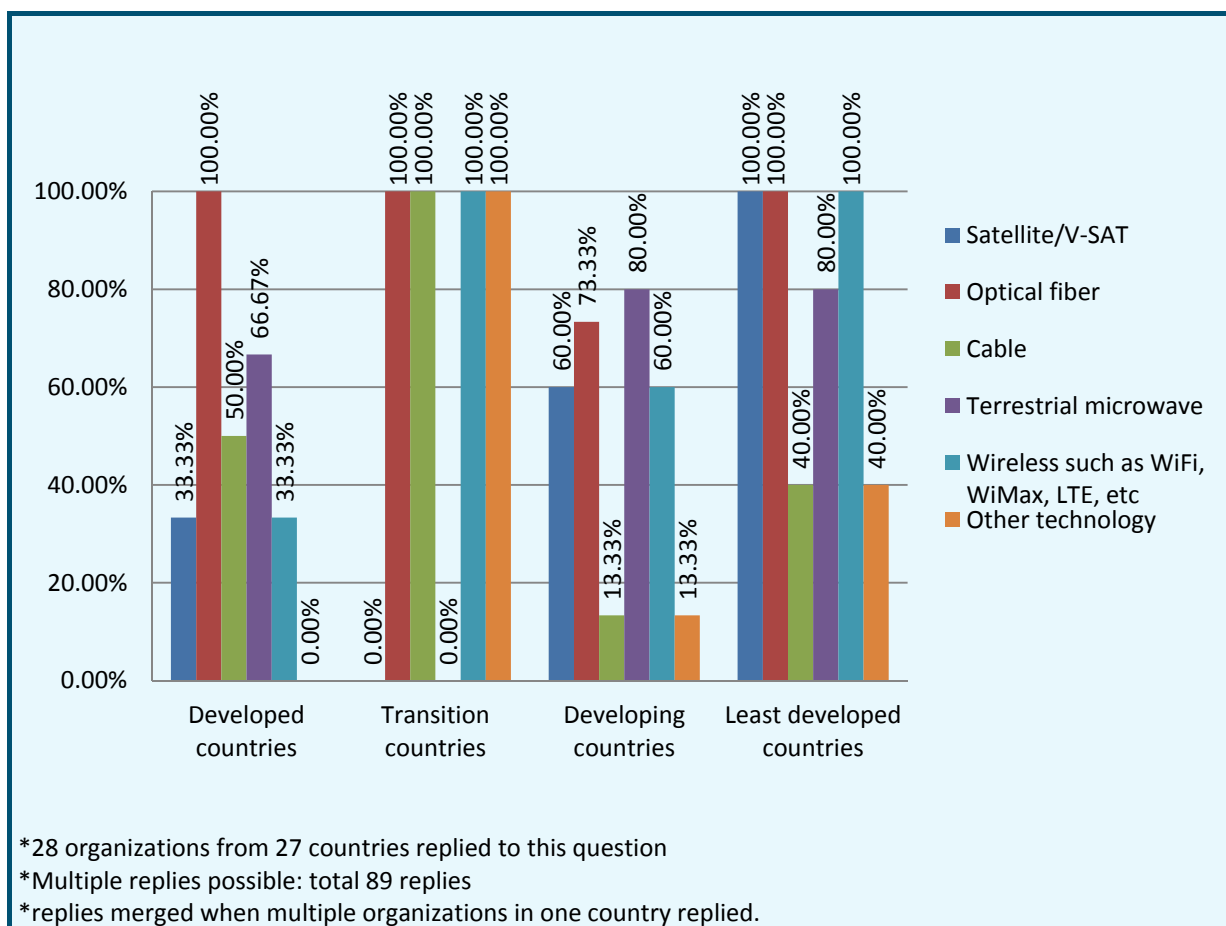

**27 What access technologies are being used in your country for connecting rural and remote areas? Please tick all that applies**

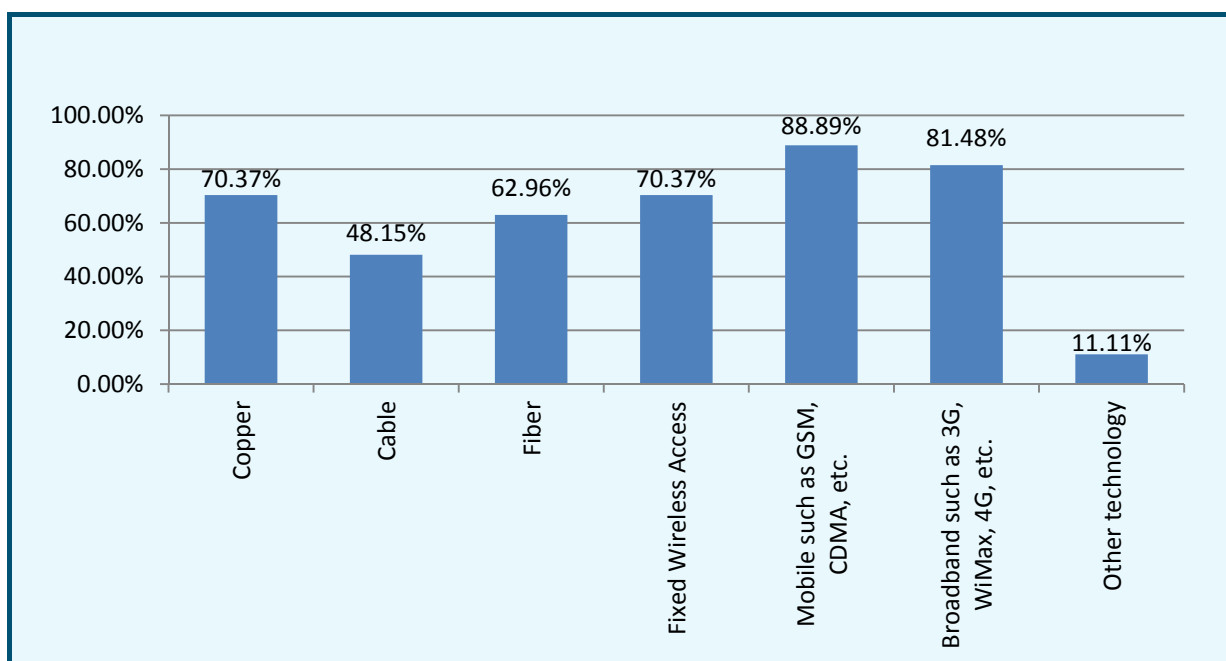

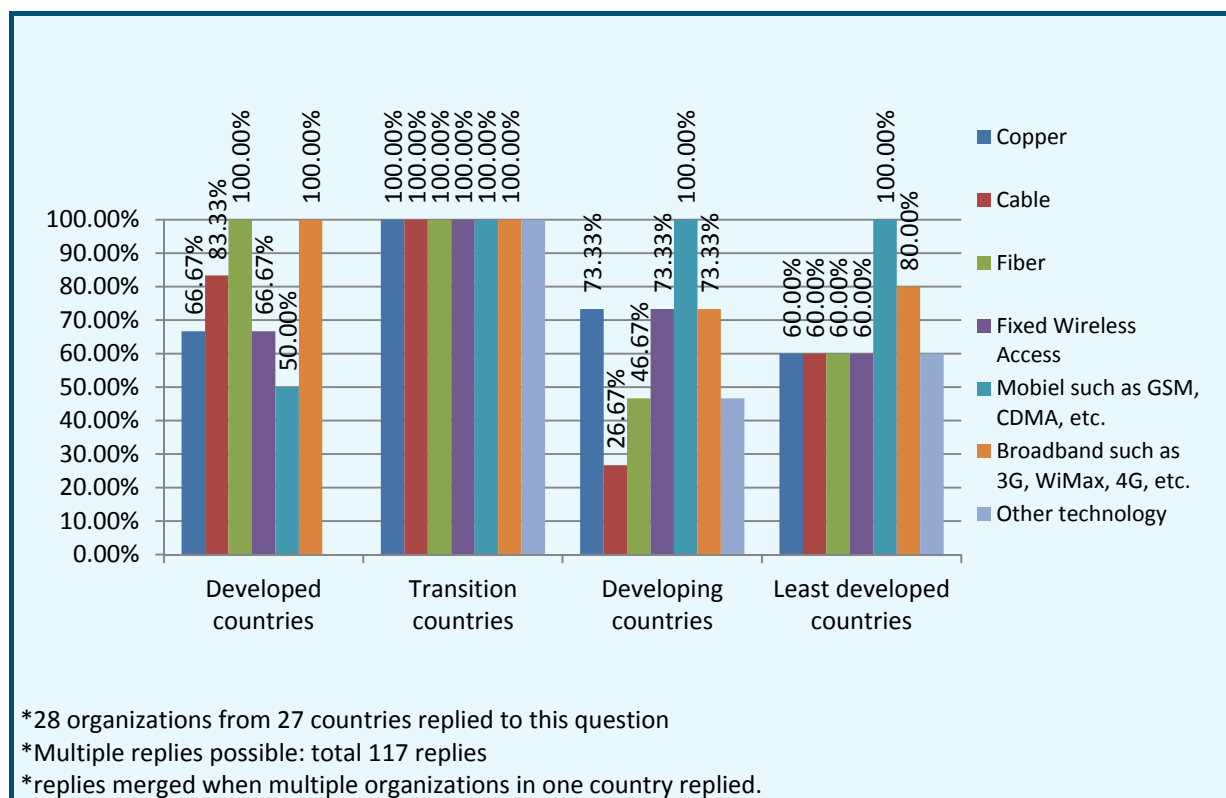

**If “Other technology” was selected, please specify:**

Telecommunications Regulatory Authority (Lebanon)	Other wireless technologies such as Pre-Wimax, CDMA etc...
Organismo Supervisor de Inversión Privada en Telecomunicaciones (Peru)	Satellite/V-SAT, microwave, WiFi.

**28 If there is any other specific policy/regulatory intervention/initiative by your government or regulatory, please elaborate**

United Kingdom Telecommunications Academy (UKTA) (International)	UKTA has both UK Government and CEPT Approval to support ITU HCD Initiatives. Should you require more detailed information as to how this is achieved see <a href="http://www.ukta.co.uk/eMCM">www.ukta.co.uk/eMCM</a> or eLLM in IT & T (provided at University of Southampton and Open University of Tanzania) on UKTA web site. All these programmes delivered by UKTA cover Policy & Regulation.
Telecommunications Regulatory Authority (Lebanon)	It is envisioned that MOT will soon issue a telecom policy which will address all sorts of access.
Ministère de la Communication et des Nouvelles Technologies (Niger)	<ul style="list-style-type: none"> <li>– Adoption of a law on the sharing of telecommunication infrastructure</li> <li>– Creation of a regulatory authority specific to the telecommunication and postal sectors, replacing the Multisectoral Regulatory Authority (ARM), which, having been responsible for regulating the telecommunication, transport, postal, water and energy sectors, was deemed too cumbersome an institution after ten years in operation.</li> </ul>

Comisión Nacional de Telecomunicaciones (CONATEL) (Paraguay)	The current policy is the National Telecommunications Plan (PNT).
Nepal Telecommunications Authority (NTA) (Nepal (Republic of))	District Optical Fiber Network project being developed; WiMax project by incumbent; Rural ICT projects in multi-stakeholders partnership model
Organismo Supervisor de Inversión Privada en Telecomunicaciones (Peru)	Deployment of the National Fibre Optic Backbone Network, serving all provincial capitals, is currently being planned. It is hoped that this high-speed transport network will provide connectivity at district level, through projects that can be financed by both private operators and district governments.
Autorité de Régulation de la Poste et des Télécommunications (Dem. Rep. of the Congo)	<ul style="list-style-type: none"> <li>– Establishment of a national broadband policy in rural or remote areas.</li> <li>– Establishment of a regulatory framework governing infrastructure-sharing, particularly in rural or remote areas.</li> <li>– Launch of a public bid for a licence for the universal broadband service.</li> <li>– Establishment of the universal service fund.</li> <li>– Creation of the National ICT Agency (Agence Nationale des TIC) to monitor all issues relating to rural or remote areas.</li> </ul>
Oman Telecommunications Regulatory Authority (TRA) (Oman)	<p>Initiative by the regulator to provide coverage to some remote villages</p> <p>900MHz refarming is the 1st refarming initiative that was conducted between the TRA and the operators in exchange of constructing 120 BTS in the rural areas.operators agreed to install total of 120 BTS site locations (60 omantel &amp; 60 nwaras)</p> <p>1800 MHz refarming in itiative is the 2nd initiative that was conducted between TRA and operators in exchange of additional mobile spectrum in 1800 MHz frequency bands operators agreed to install 80 BTS site locations in rural areas (40 Omantel &amp; 40 Nawras)</p>
Ministry of Information and Communication Technology (Mauritius)	<p>National Information and Communication Technology Strategic Plan (NICTSP) 2011–2014: Towards I–Mauritius</p> <p><a href="http://www.gov.mu/portal/goc/telecomit/file/ICTplan.pdf">www.gov.mu/portal/goc/telecomit/file/ICTplan.pdf</a></p> <p>Universal Service Fund (USF) Package for Broadband Connection at Rs 200 per month (emanates from budgetary measure 2013)</p> <p><a href="http://www.icta.mu/mediaoffice/2013/ISPs_Broadband_Connection.html">www.icta.mu/mediaoffice/2013/ISPs_Broadband_Connection.html</a></p>
ICP – Autoridade Nacional de Comunicações (ANACOM) (Portugal)	<p>See more information in, e.g.,</p> <p><a href="http://www.anacom.pt/render.jsp?categoryId=340689">www.anacom.pt/render.jsp?categoryId=340689</a></p> <p><a href="http://www.anacom.pt/render.jsp?contentId=975261">www.anacom.pt/render.jsp?contentId=975261</a></p> <p>or</p> <p><a href="http://www.anacom.pt/render.jsp?contentId=1150167">www.anacom.pt/render.jsp?contentId=1150167</a></p>
Comisión Nacional de Comunicaciones (CNC) (Argentina)	<p><u>National Plan Satellite Dishes Installation of Rural Schools and Border</u></p> <p>Objective: Bring Open Digital Television to Rural Schools and Border Argentina that are outside the coverage area of Digital Terrestrial TV, using satellite transmission through the system Direct to Home (TDH).</p> <p>Number of educational establishments: 12,000 approximately.</p> <p>Number of beneficiaries: 1,200,000 students and 300,000 teachers, approximately.</p> <p><u>Internet Program in Educational Establishments (under implementation)</u></p> <p>Objective: bring the Internet to state-run schools.</p> <p>Stage 1: estimated 4,906 establishments installing internet.</p> <p>Stage 2: 10,000 establishments.</p> <p>And in later will seek to connect to more than 40,000 state-run establishments.</p> <p><u>Plan My Digital Satellite TV</u></p> <p>Objective: to bring digital television open to families in rural areas via satellite dishes. To this date, we have connected 101 rural localities.</p> <p>Number of beneficiaries: more than 2,200 rural households across 16 provinces. The amount is estimated to reach 4,300 rural families through satellite transmission.</p>

International Telecommunication Union (ITU)  
Telecommunication Development Bureau (BDT)  
Office of the Director  
Place des Nations  
CH-1211 Geneva 20 – Switzerland  
Email: [bdtdirector@itu.int](mailto:bdtdirector@itu.int)  
Tel.: +41 22 730 5035/5435  
Fax: +41 22 730 5484

Deputy to the Director and  
Director, Administration and  
Operations Coordination  
Department (DDR)  
Email: [bdtdeputydir@itu.int](mailto:bdtdeputydir@itu.int)  
Tel.: +41 22 730 5784  
Fax: +41 22 730 5484

Infrastructure Enabling  
Environment and  
e-Applications Department (IEE)  
Email: [bdtiee@itu.int](mailto:bdtiee@itu.int)  
Tel.: +41 22 730 5421  
Fax: +41 22 730 5484

Innovation and Partnership  
Department (IP)  
Email: [bdtip@itu.int](mailto:bdtip@itu.int)  
Tel.: +41 22 730 5900  
Fax: +41 22 730 5484

Project Support and Knowledge  
Management Department (PKM)  
Email: [bdtpkm@itu.int](mailto:bdtpkm@itu.int)  
Tel.: +41 22 730 5447  
Fax: +41 22 730 5484

## Africa

Ethiopia  
International Telecommunication  
Union (ITU)  
Regional Office  
P.O. Box 60 005  
Gambia Rd., Leghar ETC Building  
3rd floor  
Addis Ababa – Ethiopia

Email: [itu-addis@itu.int](mailto:itu-addis@itu.int)  
Tel.: +251 11 551 4977  
Tel.: +251 11 551 4855  
Tel.: +251 11 551 8328  
Fax: +251 11 551 7299

Cameroon  
Union internationale des  
télécommunications (UIT)  
Bureau de zone  
Immeuble CAMPOST, 3<sup>e</sup> étage  
Boulevard du 20 mai  
Boîte postale 11017  
Yaoundé – Cameroon

Email: [itu-yaounde@itu.int](mailto:itu-yaounde@itu.int)  
Tel.: +237 22 22 9292  
Tel.: +237 22 22 9291  
Fax: +237 22 22 9297

Senegal  
Union internationale des  
télécommunications (UIT)  
Bureau de zone  
19, Rue Parchappe x Amadou  
Assane Ndoye  
Immeuble Fayçal, 4<sup>e</sup> étage  
B.P. 50202 Dakar RP  
Dakar – Senegal

Email: [itu-dakar@itu.int](mailto:itu-dakar@itu.int)  
Tel.: +221 33 849 7720  
Fax: +221 33 822 8013

Zimbabwe  
International Telecommunication  
Union (ITU)  
Area Office  
TelOne Centre for Learning  
Corner Samora Machel and  
Hampton Road  
P.O. Box BE 792 Belvedere  
Harare – Zimbabwe

Email: [itu-harare@itu.int](mailto:itu-harare@itu.int)  
Tel.: +263 4 77 5939  
Tel.: +263 4 77 5941  
Fax: +263 4 77 1257

## Americas

Brazil  
União Internacional de  
Telecomunicações (UIT)  
Regional Office  
SAUS Quadra 06, Bloco "E"  
11<sup>o</sup> andar, Ala Sul  
Ed. Luis Eduardo Magalhães (Anatel)  
70070-940 Brasília, DF – Brazil

Email: [itubrasilia@itu.int](mailto:itubrasilia@itu.int)  
Tel.: +55 61 2312 2730-1  
Tel.: +55 61 2312 2733-5  
Fax: +55 61 2312 2738

Barbados  
International Telecommunication  
Union (ITU)  
Area Office  
United Nations House  
Marine Gardens  
Hastings, Christ Church  
P.O. Box 1047  
Bridgetown – Barbados

Email: [itubridgetown@itu.int](mailto:itubridgetown@itu.int)  
Tel.: +1 246 431 0343/4  
Fax: +1 246 437 7403

Chile  
Unión Internacional de  
Telecomunicaciones (UIT)  
Oficina de Representación de Área  
Merced 753, Piso 4  
Casilla 50484, Plaza de Armas  
Santiago de Chile – Chile

Email: [itusantiago@itu.int](mailto:itusantiago@itu.int)  
Tel.: +56 2 632 6134/6147  
Fax: +56 2 632 6154

Honduras  
Unión Internacional de  
Telecomunicaciones (UIT)  
Oficina de Representación de Área  
Colonia Palmira, Avenida Brasil  
Ed. COMTELCA/UIT, 4.º piso  
P.O. Box 976  
Tegucigalpa – Honduras

Email: [itufegucigalpa@itu.int](mailto:itufegucigalpa@itu.int)  
Tel.: +504 22 201 074  
Fax: +504 22 201 075

## Arab States

Egypt  
International Telecommunication  
Union (ITU)  
Regional Office  
Smart Village, Building B 147, 3rd floor  
Km 28 Cairo – Alexandria Desert Road  
Giza Governorate  
Cairo – Egypt

Email: [itucairo@itu.int](mailto:itucairo@itu.int)  
Tel.: +202 3537 1777  
Fax: +202 3537 1888

## Asia and the Pacific

Thailand  
International Telecommunication  
Union (ITU)  
Regional Office  
Thailand Post Training Center, 5th  
floor,  
111 Chaengwattana Road, Laksi  
Bangkok 10210 – Thailand

Mailing address  
P.O. Box 178, Laksi Post Office  
Laksi, Bangkok 10210 – Thailand

Email: [itubangkok@itu.int](mailto:itubangkok@itu.int)  
Tel.: +66 2 575 0055  
Fax: +66 2 575 3507

Indonesia  
International Telecommunication  
Union (ITU)  
Area Office  
Sapta Pesona Building, 13th floor  
Jl. Merdan Merdeka Barat No. 17  
Jakarta 10001 – Indonesia

Mailing address:  
c/o UNDP – P.O. Box 2338  
Jakarta 10001 – Indonesia

Email: [itujakarta@itu.int](mailto:itujakarta@itu.int)  
Tel.: +62 21 381 3572  
Tel.: +62 21 380 2322  
Tel.: +62 21 380 2324  
Fax: +62 21 389 05521

## CIS countries

Russian Federation  
International Telecommunication  
Union (ITU)  
Area Office  
4, Building 1  
Sergiy Radonezhsky Str.  
Moscow 105120  
Russian Federation

Mailing address:  
P.O. Box 25 – Moscow 105120  
Russian Federation

Email: [itumoskow@itu.int](mailto:itumoskow@itu.int)  
Tel.: +7 495 926 6070  
Fax: +7 495 926 6073

## Europe

Switzerland  
International Telecommunication  
Union (ITU)  
Telecommunication Development  
Bureau (BDT)  
Europe Unit (EUR)  
Place des Nations  
CH-1211 Geneva 20 – Switzerland  
Switzerland  
Email: [eurregion@itu.int](mailto:eurregion@itu.int)  
Tel.: +41 22 730 5111



International Telecommunication Union  
Telecommunication Development Bureau

Place des Nations  
CH-1211 Geneva 20

Switzerland

[www.itu.int](http://www.itu.int)