

ITU-D Regional Development Forum for the Americas Region NGN and Broadband, Opportunities and Challenges

Business Planning Case for Access

**Santo Domingo (Dominican Republic)
November 2009**

**Oscar González Soto
ITU Consultant Expert
Spain
oscar.gonzalez-soto@ties.itu.int**

Agenda

- **Context and case study definition**
- **Access assessment**
- **Business evaluation**

Planning project for Access Evolution: Questions and issues



- Does access enhancement for NGN profit in developing countries?
- What reusability may be expected in fixed access infrastructure?
- How much to invest in access for BB?
- How CAPEX and OPEX change with NGN and xDSL?
- What benefits may be addressed by infrastructure sharing?
- Others.....?

Planning project for Access Evolution: Project context and objectives



• Context for access evolution planning

- Developing countries are now faced with the a **challenge of migrating from existing PSTN networks** in urban areas to advanced NGN networks capable to provide multimedia services under limited financial conditions.
- **Access network segment is playing a key role** for provisioning of Broadband services, being dominant in investments (> than 50% of total network). This implies the need to learn and share know-how on processes, network studies and business planning activities.
- **TOT and ITU have agreed to undertake a joint case study** for the most convenient evolution of the access towards BB with multi-play capabilities and share results with countries in the Region

Planning project for Access Evolution: Project context and objectives

• Access project objectives

Following previous context and agreement, the next objectives were defined for this project:

- To undertake **network assessment and audit** for the status of the existing copper access network infrastructure in Bangkok
- **Evaluate dynamic migration models** over time towards target solution to support triple play services with at least 8 Mbps
- **To provide guidelines and recommendations on current access network capability** toward NGN including network upgrading, NGN planning and deployment of ICT-based services over the access network
- **To extract generic conclusions and experiences** with applicability to other countries of the Region

Planning project for Access Evolution: Project activities for OSP and NGN

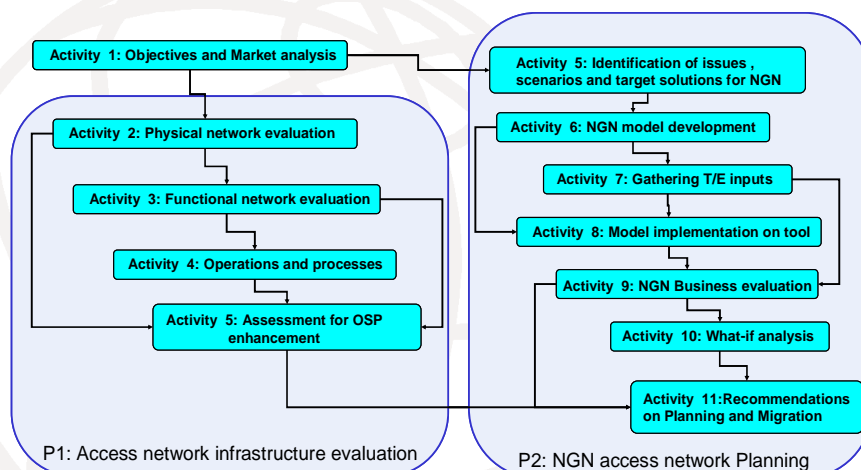

Planning project for Access Evolution: OSP architecture

Structure of the OSP Access Network at initial status

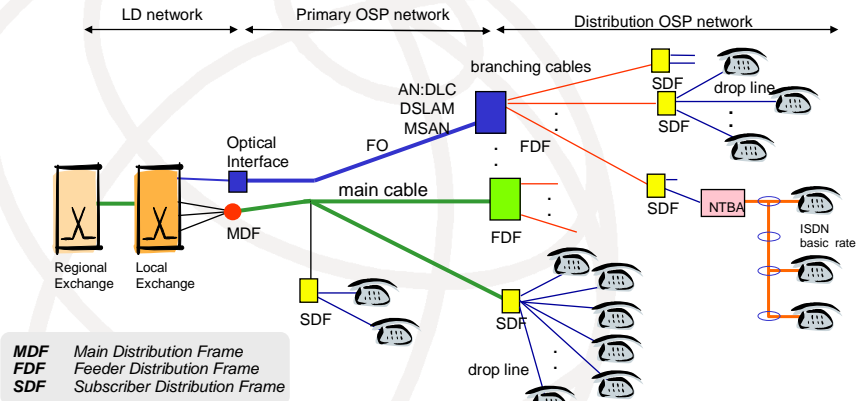

Agenda

- Context and case study definition
- Access assessment
- Business evaluation

Planning project for Access Evolution: Assessment on access : BKK areas under analysis

- Following diagram illustrates geographically the 4 BKK metropolitan areas that are the object of the study with selection of Area 3 for techno-economic evaluations

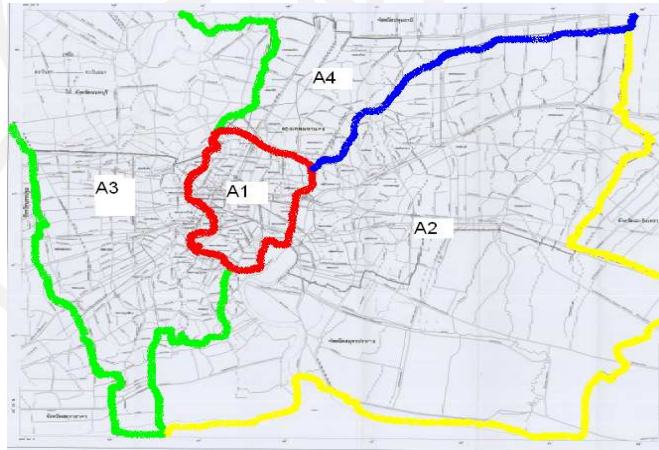

Santo Domingo (Dominican Republic) November 2009 ITU – Business case - OGS

9

Planning project for Access Evolution: Assessment on access

- Taking as a base the operational lines that generate revenues, the following diagram illustrates the ratios of different Network Elements (NE) at A3 as a characterization of the access structure.

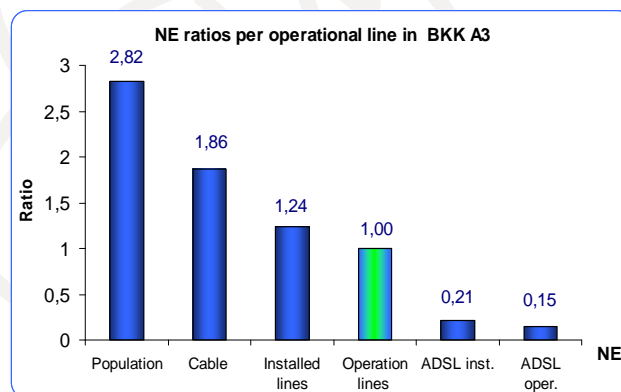

Santo Domingo (Dominican Republic) November 2009 ITU – Business case - OGS

10

Planning project for Access Evolution: Assessment on access

Physical network characterization

- Transmission for the utilization of high frequencies in access copper cables is done by the measurement of **Signal to Noise ratio (SNR)** measured in dBs. Attenuation of transmission signal increases as a function of characteristics in order of importance:
 - ✦ The **length** of cable
 - ✦ Cable **gauge** and material
 - ✦ Amount of crosstalk between adjacent cables (function of cable **age, isolation, humidity and filling degree**)
 - ✦ Cable **discontinuities** through the path (function of the historical connection practices)
 - ✦ **Noise gathered by induction** of electromagnetic sources at customer premises or along the cable path (i.e.: radio emission, electrical power, etc. as a function of the Electromagnetic Compatibility practices)

Planning project for Access Evolution: Assessment on access

- LL length distribution within the A1 and A3 of Bangkok shows a relatively good shape due to the population settlements around nucleus and good historical practices in topology design

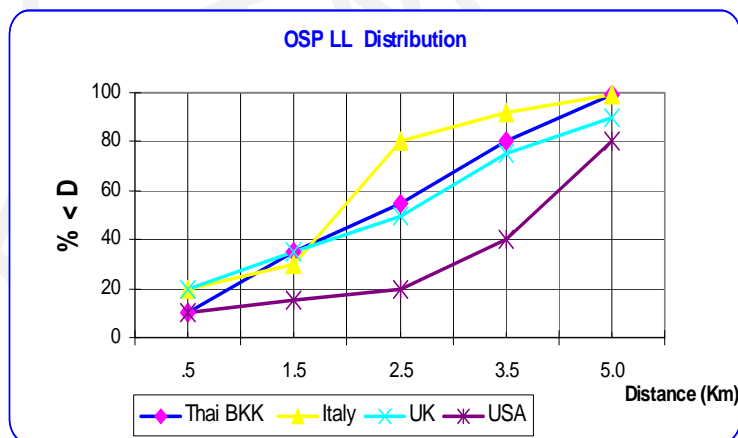

Planning project for Access Evolution: Assessment on access

- Capabilities of the xDSL technologies including both ADSL and VDSL are given in the diagram below as a function of the distance: Blue line gives the **maximum theoretical** capacity in Mbps with cables at lab conditions while the red line illustrates the **engineering capacity** at real conditions of the field

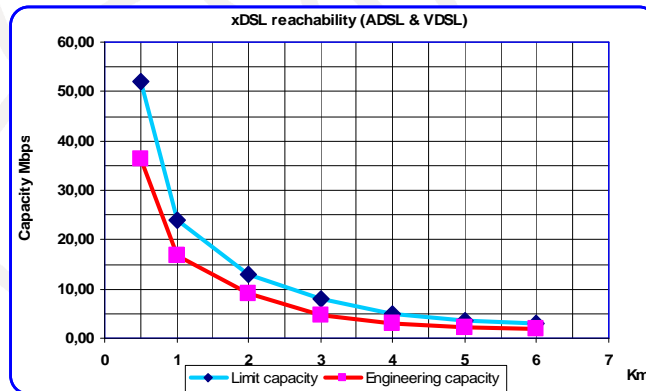

Planning project for Access Evolution: Assessment on access

- Cable gauges in A1 and A3 are dominant for .4 and .5 mm. as indicated in the diagram thus limiting the data rates at the high end of the loop

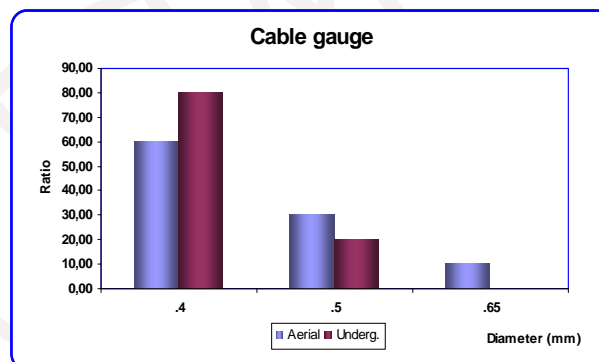

Planning project for Access Evolution: Assessment on access

- Cable ages in A1 and A3 follow the distribution indicated with significant proportion of cables at the end or close to the end of life cycle (more than 15 years) that should be enhanced

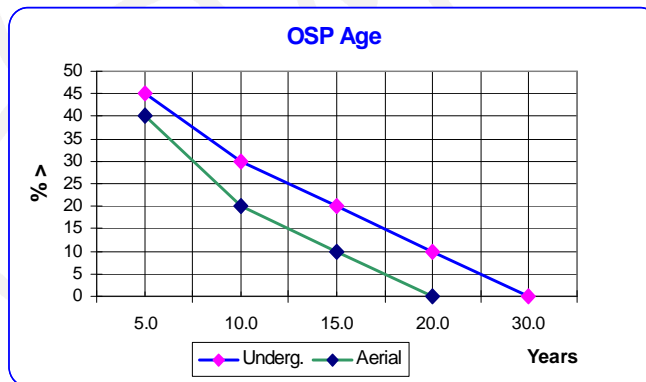

Planning project for Access Evolution: Outcome on OSP assessment

- Outside plant in access has **important reusability for xDSL solutions** needing enhancement for wider deployment of 8 Mbps services mainly in the secondary section and new remote unite associated to the cabinets
- It is recommended to have OSP information and **inventory in digital** and integrated form by use of the applications associated to the OSS
- It is recommended to have a **wide characterization of the local loop** properties by use measurements with proper sampling techniques for a first step characterization and use of specific testing equipment for massive measurement later.
- In order to avoid multiple sequential civil works it is recommended to agree among different players for a common **deployment in shared mode** (i.e.: common works with assigned ducts per operator or even shared ducts options)

Agenda

- Context and case study definition
- Access assessment
- **Business evaluation**

Planning project for Access Evolution: Access Modelling: Global migration scenarios

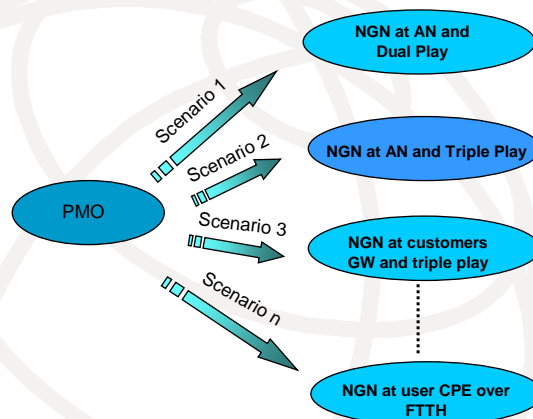

Access migration scenarios are defined by the evolution between the pair of originating (Present Mode of Operation) and destination network configurations

Planning project for Access Evolution: Access Modelling: Specific migration scenarios for NGN

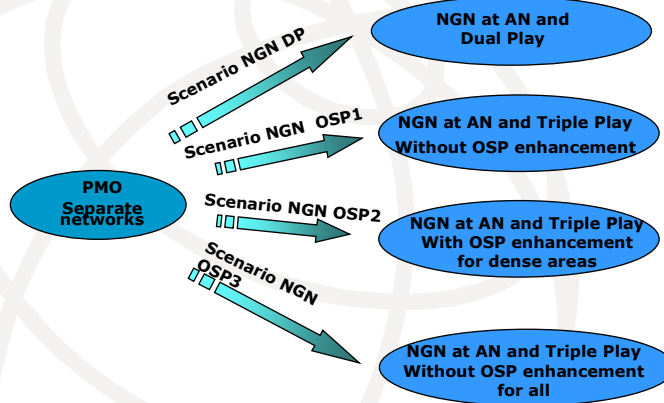

Access migration scenarios evaluated in the case study as the most convenient for the current country situation

Planning project for Access Evolution: Functional scenarios

- Historical configuration to be modeled as scenario S1 or Present Mode of Operation (PMO) with separated voice and data networks and the following functional elements

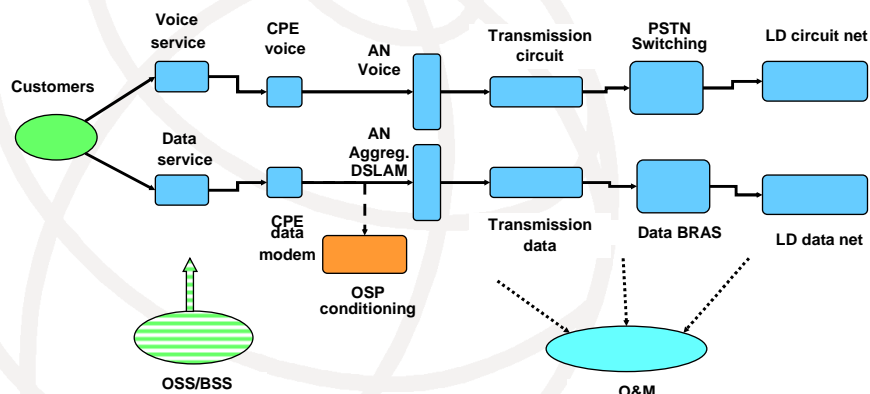

Planning project for Access Evolution: Functional scenarios

- New configuration to be modeled as scenarios S2, S3, S4, S5 or NGN with convergence of network and services at the access node either with provisioning of dual play: VoIP and BB internet or triple play adding IPTV

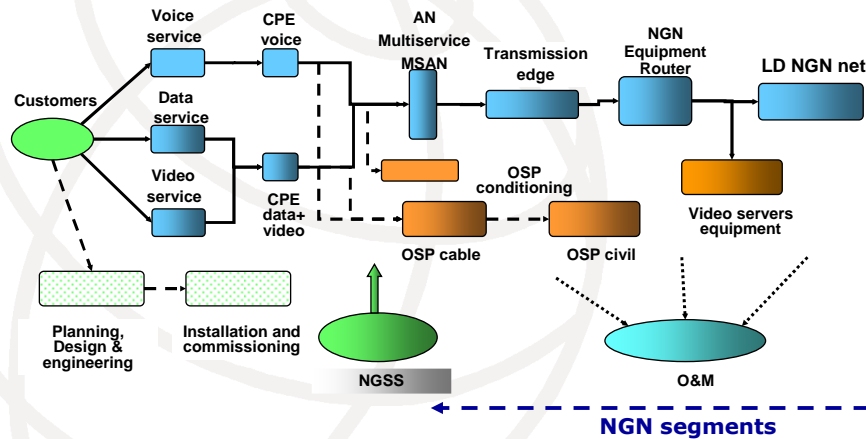

Planning project for Access Evolution: Network structure for NGN based deployments

- New deployments of ADSL receiving service through an IP based network with access by MSANs connected to a metroLAN and an IP Core towards the Gateway to Internet as described in the reference diagram

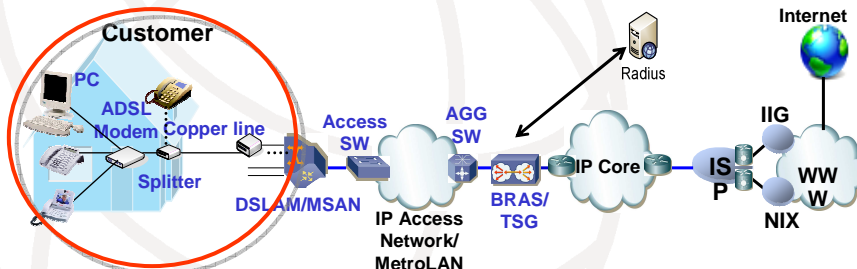

Planning project for Access Evolution Business evaluations



General assumption for the evaluations (I)

- Analysis period for the evaluations of 10 years in order to be able to see the life-cycle effects of different network element types
- Standard reference financial parameters for discount rates of 10% during the evaluation period and long term perpetuity rate to evaluate terminal values of network (3%)
- Life cycles for NE: of 4 years for CPEs, 6 years for AN, 6 to 8 years for core nodes and 20 years for OSP
- Existing installed equipments not at the end of life-cycle at the start of the period thus requiring substitution at the corresponding life expiration

Planning project for Access Evolution Business evaluations



Assumptions for BKK Area 3 (II)

- Population of 2,383.811 inhabitants at end 2008
- Population density of 3.833 at year 2008
- Customer density: 569 customers per Km² at 2008
- Initial Market share at the country: 56% for fixed lines and 36% for ADSL lines
- Potential market in lines for TOT 460.000 at year 10
- ADSL LL length for 8 Mbps. guarantee: 2 Km or 1,43 geographical radius
- Average number of cables per operational line 1,86
- Proportion of reachable LL for BB 8 Mbps. 45%
- Proportion Aerial/underground distribution network: 70/30

Planning project for Access Evolution Business evaluations

Assumptions for BKK Area 3 (III)

- Migration speed towards NGN at a medium pace in 3 years with rates of 20/60/20 that is feasible in a region (note that is not feasible in all regions at the same time for financial and know-how limitations)
- Tariffs for voice service decreasing 5% per year
- Tariffs for data service of 1000 bahts/month for BB access of 8 Mbps and decreasing 3% per year
- Tariffs for IPTV equivalent to current market silver type: 750 bahts
- Pricing Access Nodes for an initial configuration of voice /data ports: 80/20
- Company financed CPEs for users: 30% for traditional, 50% for new voice/data and 60% for new IPTV.

Planning project for Access Evolution Business evaluations: Triple play

- Evolution of services demand projected with the mentioned assumptions for voice, BB internet and IPTV with VOD as a function of customer geographical coverage that depends on the level of OSP enhancement

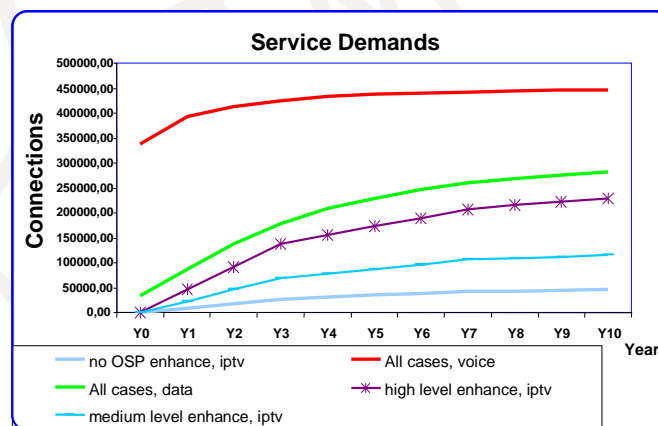

Planning project for Access Evolution Business evaluations: Triple play

- Global project evaluator: Net Present Value (NPV) at perpetuity rate shows a gain for all NGN alternatives that is high higher as wider enhancement of OSP and more customers reached for BB services and IPTV. Thus new revenues and convergence economy of scale largely compensate the high OSP investments

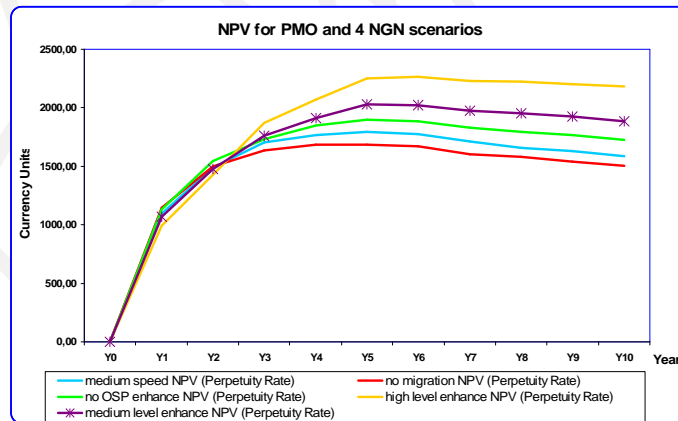

Santo Domingo (Dominican Republic) November 2009

ITU – Business case - OGS

27

Planning project for Access Evolution Business evaluations: Triple play

- Differential NPV at perpetuity rate trough time: gain after year 3 justifies the important investments in OSP and access modernization with NPV increasing through time in proportion to the number of reachable customers that generate new revenues

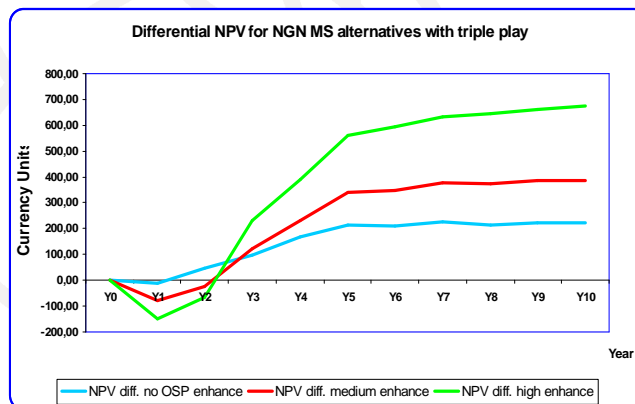

Santo Domingo (Dominican Republic) November 2009

ITU – Business case - OGS

28

Planning project for Access Evolution Business evaluations: Triple play

- Capital expenditure shows a different profile at the 4 scenarios due to the important investments at the transition years in OSP modernization, new integrated Access Nodes and renovation of multiservice CPEs but converging at medium term when modernization completed

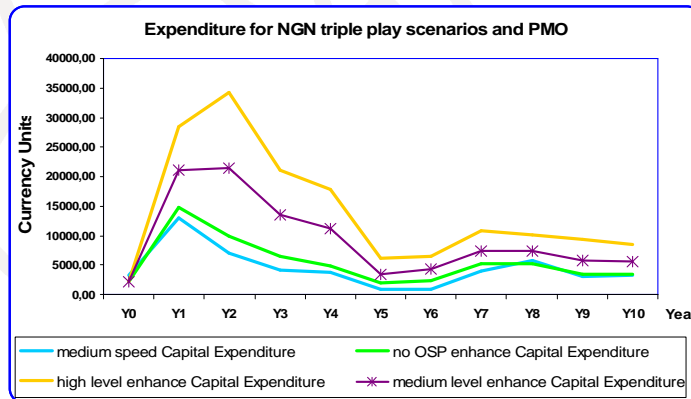

Planning project for Access Evolution Business evaluations: Triple play

- Differential expenditure and revenues with the PMO illustrates the importance of migration towards NGN with a high capacity access network to benefit from the new revenues and positioning for competition

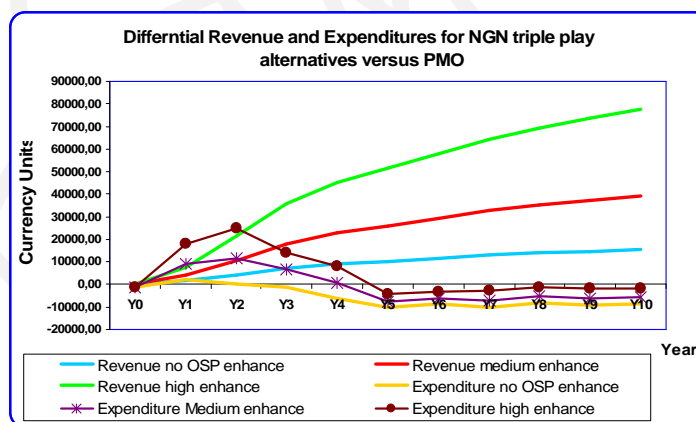

Planning project for Access Evolution Business evaluations: Triple play

- Diagram provides the services revenues evolution through time as function of the assumptions taken. Voice revenues will decrease due to tariff deterioration by high competition and BB internet and IPTV will increase due to the number of incorporated customers. At period end data and IPTV services revenues will be dominant (66%) over voice even with a lower penetration

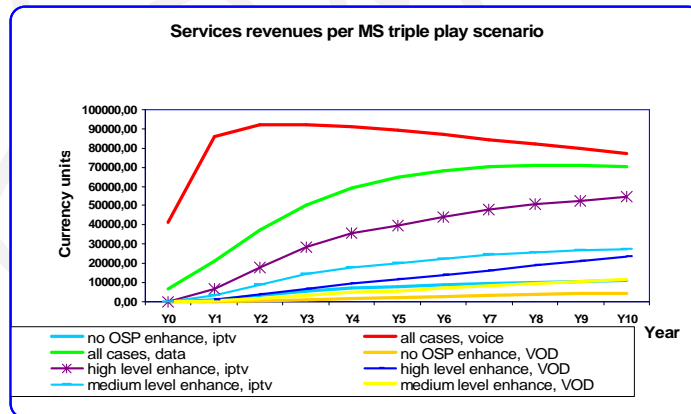

Planning project for Access Evolution Business evaluations: Triple play

- Diagram illustrates the investment per category of network elements in percentage for the accumulated value in the 10 years period in the scenario of full network enhancement. The three main investments correspond to the modernization of secondary network, the provisioning of new CPEs with video capability and the remote multiservice nodes to reach all population

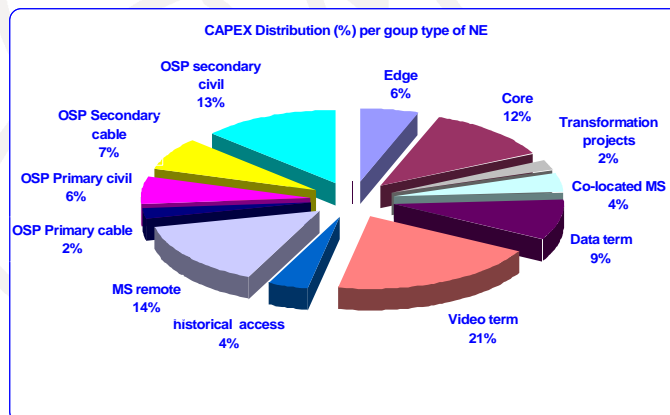

Planning project for Access Evolution Business evaluations: Triple play

- Diagram shows the operational costs in percentage per category of elements subject to operation and maintenance expenses considered in the 10 years period. Operation and maintenance for the equipments and activities at the network periphery are the main contributors to the expenses with customer service and remote nodes taking the lead

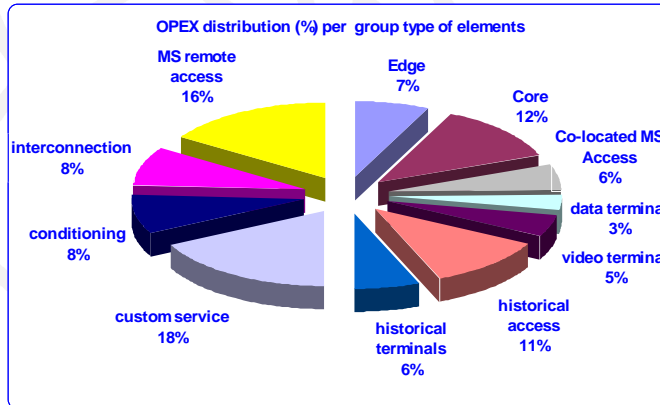

Planning project for Access Evolution Business sensitivity to tariffs: Triple play

- Differential NPV between the three scenarios per level of OSP modernization illustrates the sensitivity to the tariffs of IPTV and VOD services. But even with a reduction to half project is positive after year 4 due to the efficiency of convergence and economies of scale in triple play

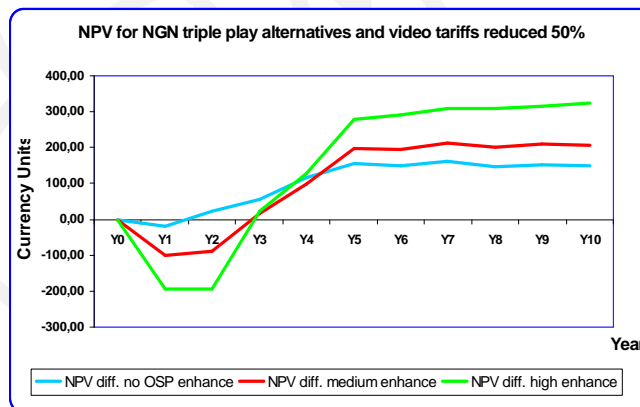

Planning project for Access Evolution Business evaluations: Migration steps

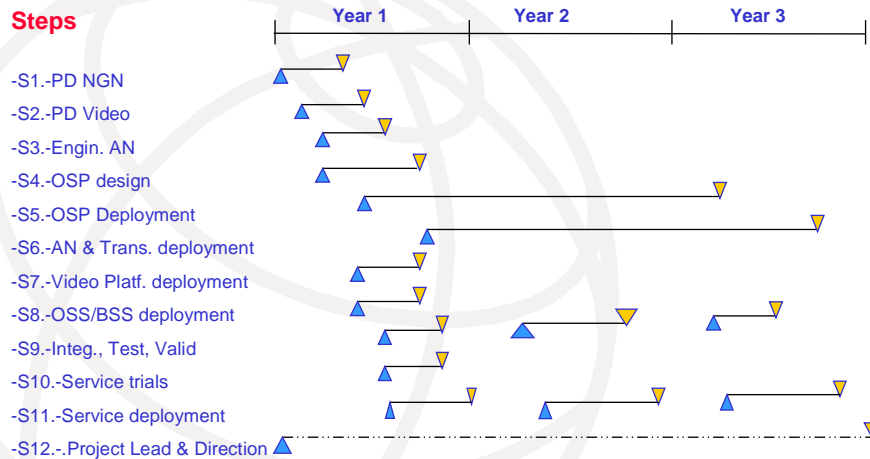

• Example of project design and execution. Should be in close collaboration to Equipment, Content and Service providers

Santo Domingo (Dominican Republic) November 2009 ITU – Business case - OGS

35

Planning project for Access Evolution Business evaluations: Outcome

- Access modernization for NGN solutions to allow triple play services (at 8 Mbps.) show an important increase in the Net Present Value of the network due to the convergence efficiencies and position the company for a higher revenues and competition level in the market
- Introduction of IPTV and VOD should be based on negotiations with content providers that provide attractive and high quality content in order to assure important customer adoption rates and loyalty.
- Quality of Service, Service Availability, Customer Care and Sustained Bit Rate (i.e.: all path dimensioning at 80% of peak rate) guarantee are the decisive factors for a customer to select a new provider or remain at the current one.
- Customer Care platform is recommended with traffic dimensioning ensuring rapid response to calls and with differentiation of service per customer class, history of previous customer calls and SLA.

Santo Domingo (Dominican Republic) November 2009 ITU – Business case - OGS

36

Planning project for Access Evolution Business evaluations: Outcome



• **Further studies** and sensitivity analysis recommended for the access scenarios include the following ones:

A) **Lower density cases** in suburban scenarios in order to analyze up to which density and services mix the current conclusions of this study could be maintained.

B) New architectures with **IP closer to the customer at an all IP CPE** that allows for services end-to-end IP, cost reduction in the node but higher investments in customer CPE renovation

C) FTTH for services requiring 30 or 100 Mbps according to customer density services demand and OSP status versus VDSL solutions

D) Infrastructure sharing modeling and business evaluation for cases as well as for a common underground renovation/installation of ducts at a single shot for all involved companies (Telecom, CATV, Electricity, etc.)

Planning project for Access Evolution : Conclusions



New service revenues pay for the required infrastructure enhancement for high speeds

High impact of economy of scale benefits for convergence in multiservice triple play

Powerful modeling and support tools needed to optimize evolution