



ITU-APT Workshop on NGN Planning

16 – 17 March 2007, Bangkok, Thailand

Network Architecture Migration towards NGN

Oscar González Soto
ITU Consultant Expert
Strategic Planning and Assessment



Network Architecture towards NGN Content

- **Key factors for the evolution towards NGN**
 - Services and revenue motivations.
 - Requirements and issues
- **Network architecture consolidation at transit, local and access levels**
 - Topology and architecture migration
- **IMS rational and structure**
 - Evolution and benefits



Network Architecture towards NGN Key Factors: Motivation



- **New services and revenue** increase with multimedia services:
 - Compensate voice revenue reduction and increase BB related business
- **Cost reductions** by sharing network infrastructure and systems
 - Savings are a function of network scenario, equipment modernization status and customers grow speed
- **Simplification of O&M**, thus lowering OPEX
 - Integrated operation platforms, maintenance and training



Network Architecture towards NGN Key Factors: Operator Requirements (I)



- **Business continuity** required to maintain ongoing dominant services and customers that require carrier-grade service
- **Flexibility** to incorporate existing new services and react quickly to the ones that appear on real time (main advantage of IP mode)
- **Profitability** to allow feasible return on investments and in the best practices market values



Network Architecture towards NGN Key Factors: Operator Requirements (II)



- **Survivability** to allow service assurance in case of failures and external unexpected events
- **Quality of Service** to guarantee the **Service Level Agreements** for different traffic mixes, conditions and overload.
- **Interoperability across networks** to allow to carry end to end services for flows in different network domains



Network Architecture towards NGN Content



- **Key factors for the evolution towards NGN**
 - Services and revenue motivations.
 - Requirements and issues
- **Network architecture consolidation at transit, local and access levels**
 - Topology and architecture migration
- **IMS rational and structure**
 - Evolution and benefits



Network Architecture towards NGN Architecture Consolidation: Topology



Topological changes impact on infrastructure and are slower to implement than technology substitution

- **Less network nodes and links** due to the higher capacity of systems (one order of magnitude).
- **Same capillarity** at access level due to identical customer location
- Topological **connectivity higher** for high capacity nodes and paths due to security
- **High protection** level and diversity paths/sources in all high capacity systems, both at functional and physical levels



Network Architecture towards NGN Existing networks and architecture

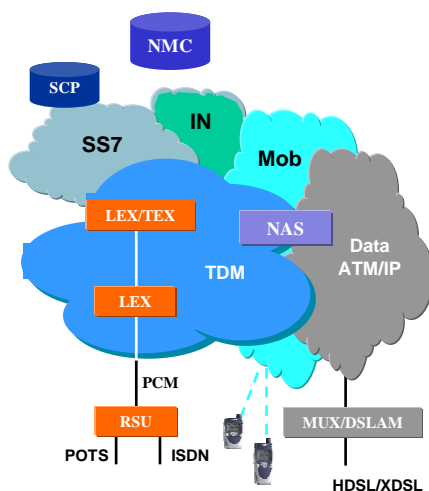

- 5 different network types to handle telecom services
- TDM for fixed and mobile networks working in circuit mode with end to end reserved paths
- SS7 and IN network working with message switching mode
- Data network working with leased lines and packet mode with different and conventional IP protocols



Network Architecture towards NGN Existing networks and architecture

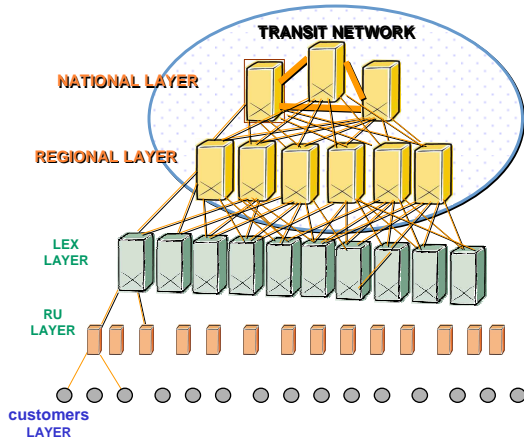

- Hierarchical topology with 4 to 5 layers, connectivity to the upper next layer and within each layer as a function of economical optimization
- Number of nodes as a function of O/D traffic and nodes capacity
- Service handling for media, signaling and control at all exchange nodes
- Carrier grade quality with well defined QoS criteria and standardized engineering rules

March 2007

ITU/BDT Network Architecture consolidation - O.G.S.

slide 9



Network Architecture towards NGN Architecture: NGN Layers

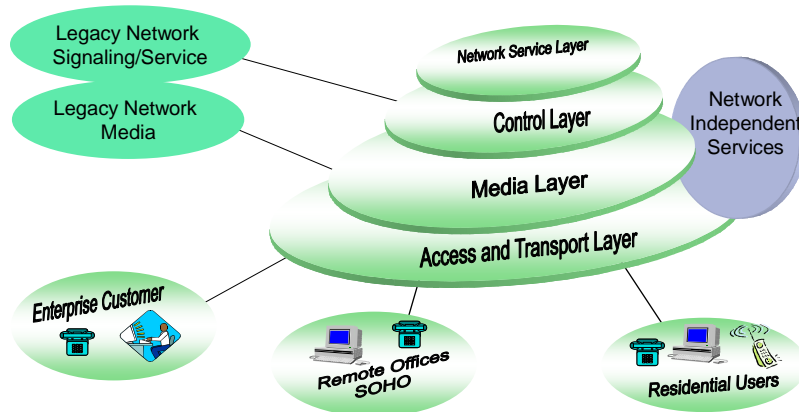

March 2007

ITU/BDT Network Architecture consolidation - O.G.S.

slide 10



Network Architecture towards NGN

Architecture migration: Topology



What changes from current scenario towards target network ?

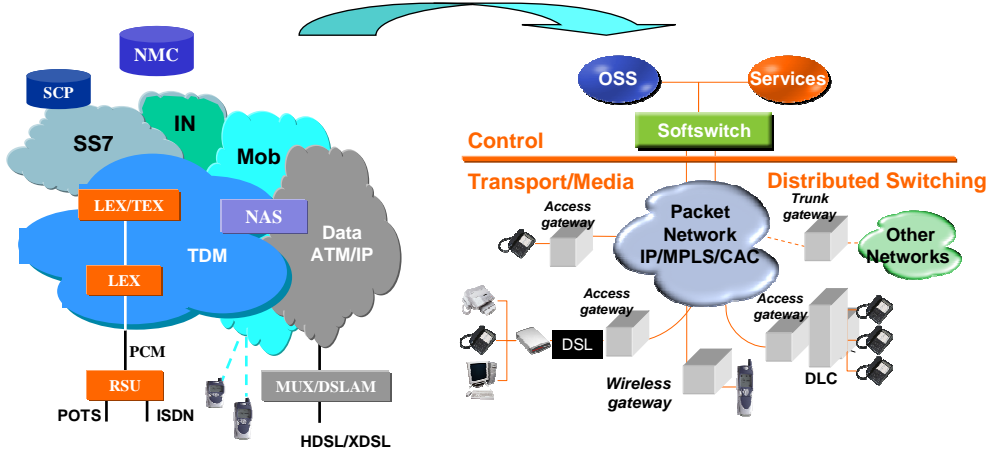

March 2007

ITU/BDT Network Architecture consolidation - O.G.S.

slide 11



Network Architecture towards NGN

Architecture Consolidation: Topology

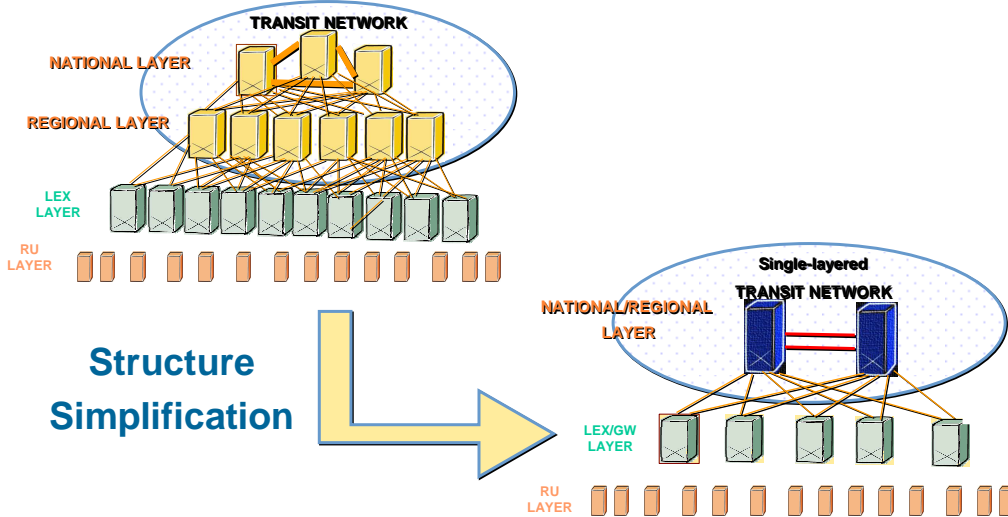

March 2007

ITU/BDT Network Architecture consolidation - O.G.S.

slide 12



Network Architecture towards NGN Architecture Consolidation: Access



Access dominated by physical infrastructure cost and deployment time

- Quick deployment of DSL and Multimedia Services
- FO closer to customer when implementing new outside plant or renovating existing one
- New Wireless technologies for low density customer scenarios
- Shorter LL length than classical network to be prepared for high bandwidth Multimedia services



Network Architecture towards NGN Architecture Consolidation: Wireline Access



Typical historical Access Network structure

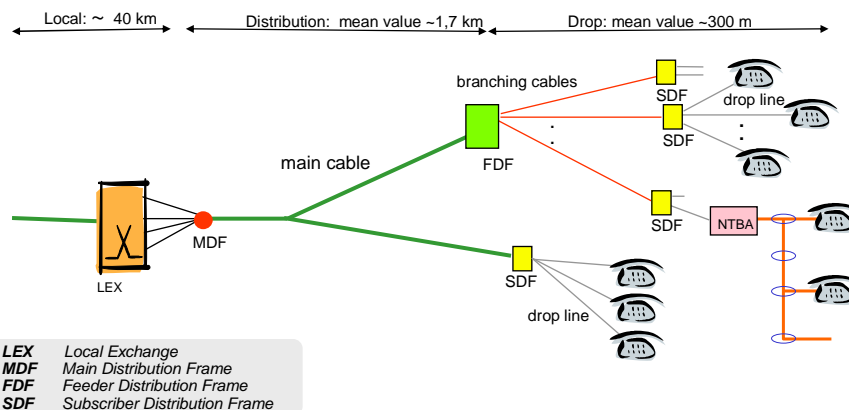



Network Architecture towards NGN Architecture Consolidation: Access evolution



Typical Access Network evolution

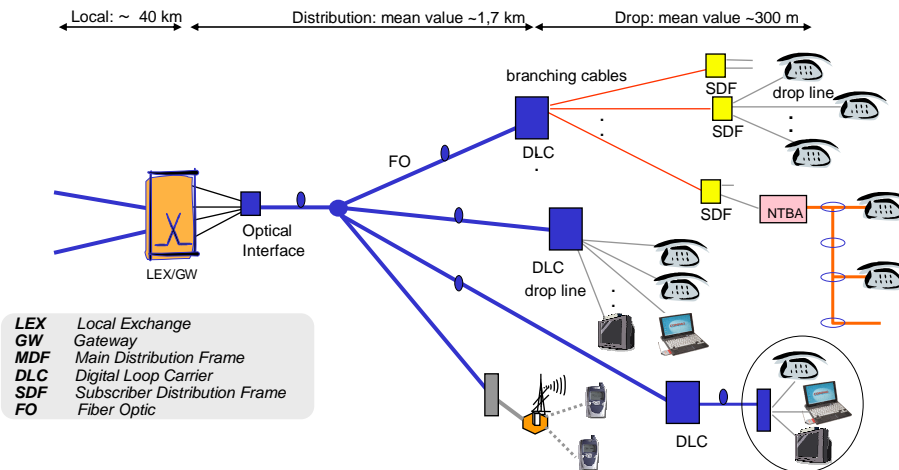

March 2007

ITU/BDT Network Architecture consolidation - O.G.S.

slide 15



Network Architecture towards NGN Architecture Consolidation: Local



Dominated by functions migration investment and interoperability

- Move from joint switching and control to separated control and media GW
- Introduce Multimedia Services at all areas
- Optimize number, location of nodes and interfaces among existing and new network
- Requires longer time and higher investments due to variety of geo-scenarios and geographical distribution

March 2007

ITU/BDT Network Architecture consolidation - O.G.S.

slide 16



Network Architecture towards NGN Architecture Consolidation: Local

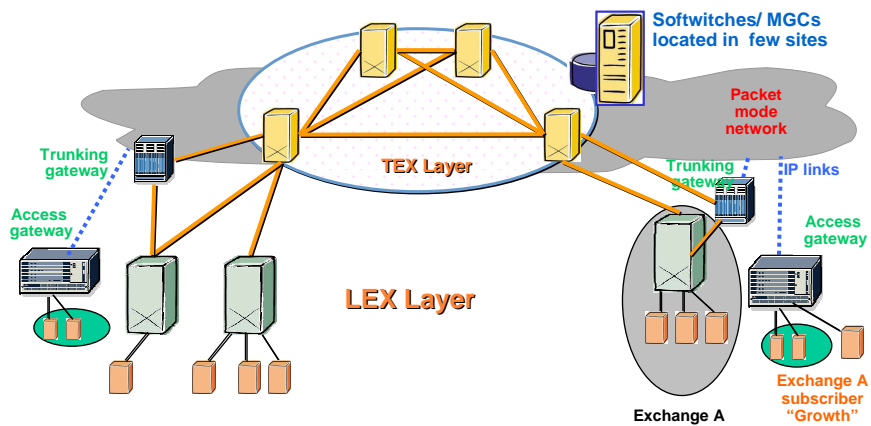

March 2007

ITU/BDT Network Architecture consolidation - O.G.S.

slide 17



Network Architecture towards NGN Architecture Consolidation: Core



Dominated by high capacity and protection level

- Overlay deployment for full coverage in all regions
- Quick deployment needed for homogeneous end to end connections
- Strong requirements for high quality, protection and survivability
- Importance of the optimization for location and interconnection

March 2007

ITU/BDT Network Architecture consolidation - O.G.S.

slide 18



Network Architecture towards NGN Architecture Consolidation: Core

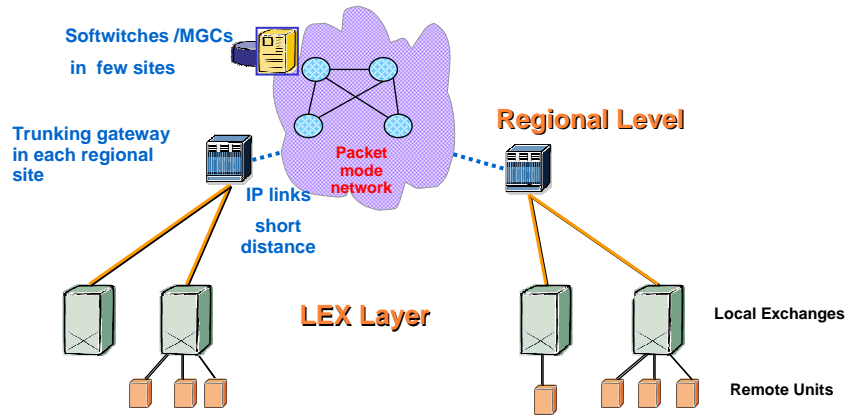

March 2007

ITU/BDT Network Architecture consolidation - O.G.S.

slide 19



Network Architecture towards NGN Architecture Consolidation: Core

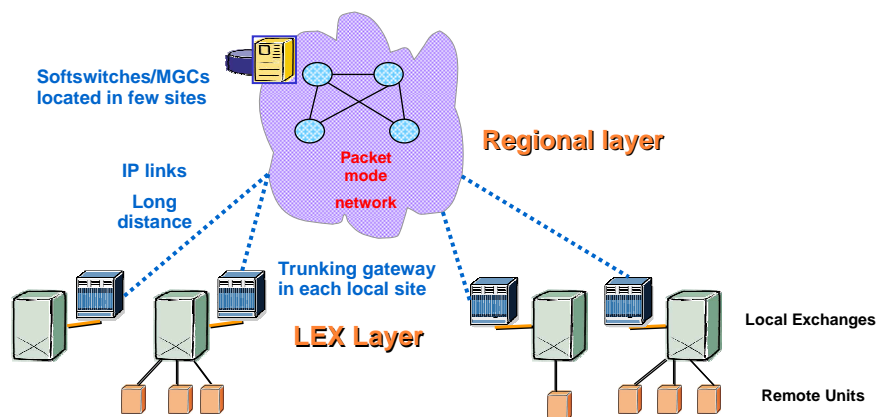

March 2007

ITU/BDT Network Architecture consolidation - O.G.S.

slide 20



Network Architecture towards NGN Architecture Consolidation: Combined Segments



Where to start and how to co-ordinate migration?

Network “consolidation”

Cost Optimisation of the network

- Reducing nodes and increase their capacity
- Deployment of ADSL and multiservice access

Network expansion

NGN solution :

- **Cap and Grow**; this means keeping the existing PSTN network as it is, and grow demand with NGN equipment

Network replacement

Replacement of out-phased (end of life) TDM equipment

- gradual replacement : this means **coexistence** of the two technologies
- **full accelerated replacement** with a short transition period

Need to optimize overall network evolution: technically and economically



Network Architecture towards NGN Architecture Consolidation: Combined Segments (I)

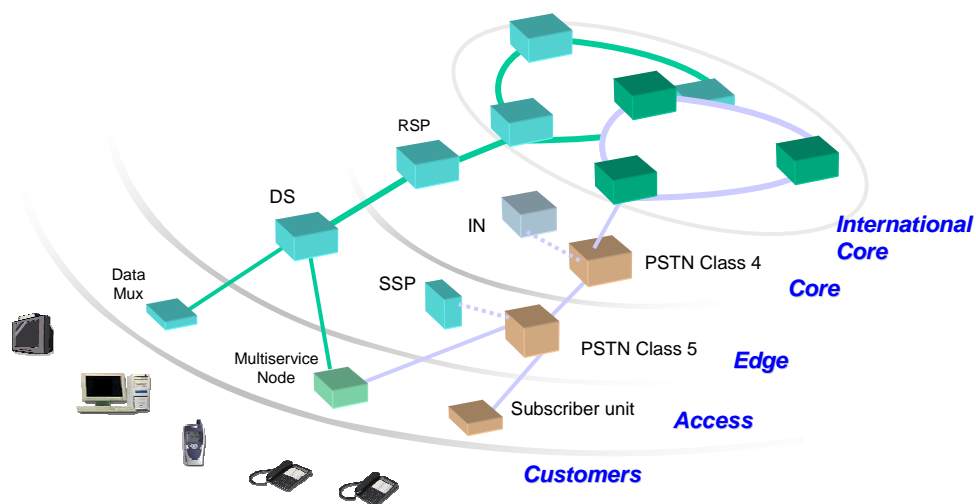



Network Architecture towards NGN Architecture Consolidation: Combined Segments (II)

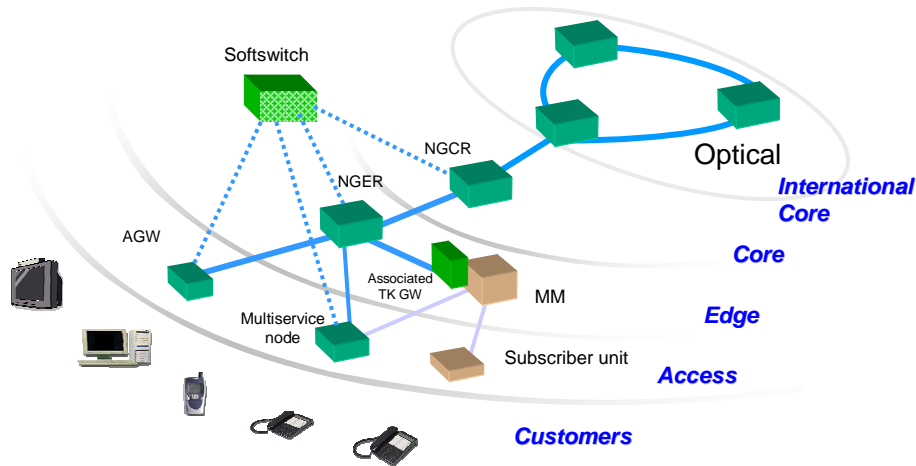

March 2007

ITU/BDT Network Architecture consolidation - O.G.S.

slide 23



Network Architecture towards NGN Architecture Consolidation: Combined Segments



Overall impact of evolution on network CAPEX and OPEX

CAPEX

- TDM and NGN CAPEX are **close**
- NGN CAPEX in the first years driven by **geographic coverage**
- Access systems represent a large part of CAPEX
 - **similar values** in TDM and NGN

OPEX

- OPEX in NGN tends to be **lower**
- Migration scenarios will have a **mix** of TDM OPEX (installed base) and NGN OPEX (substitution and growth)
- Significant impact of manpower cost due to **convergence** in operations

Key factors for the evaluation: Geo-scenarios, Network grow rates, Aging of equipment, New services

March 2007

ITU/BDT Network Architecture consolidation - O.G.S.

slide 24



Network Architecture towards NGN Content



- **Key factors for the evolution towards NGN**
 - Services and revenue motivations.
 - Requirements and issues
- **Network architecture consolidation at transit, local and access levels**
 - Topology and architecture migration
- **IMS rational and structure**
 - Evolution and benefits



Network Architecture towards NGN Unified IMS Model for Mobile and Fixed



What is IMS?

- **Concept:**
 - An Industry Standard Service Architecture (SA) and Core Network (CN) architecture
 - An IP Multimedia Services Architecture
 - A Solution for Service Transparency
- **Characteristics**
 - Defined with Open Standards from 3GPP and ETSI
 - Based on IETF Protocols (SIP, RTP, RTSP, COPS, DIAMETER, etc.)
 - Designed for both Wireless and Wireline Networks and for Fixed and Mobile Convergence (FMC)
 - Capable of Interworking with PSTN (i.e. legacy IN-based services)
- **Key actors:**
 - Operators
 - ETSI, TISPAN, ITU-T
 - Equipment vendors



Network Architecture towards NGN Unified IMS Model for Mobile and Fixed



Why IMS?

- Deliver person-to-person real-time IP-based multimedia communications
 - Person-to-person, person-to-machine
- Fully integrate real-time with non-real-time multimedia communications.
 - i.e., live streaming and chat
- Enable different services and applications to interact
 - i.e., combined use of presence and instant messaging
- Easy user setup of multiple services in a single session, or multiple synchronized sessions
- Operators have better control of service value chain
 - End-to-end QoS



Network Architecture towards NGN IMS Architecture Layers

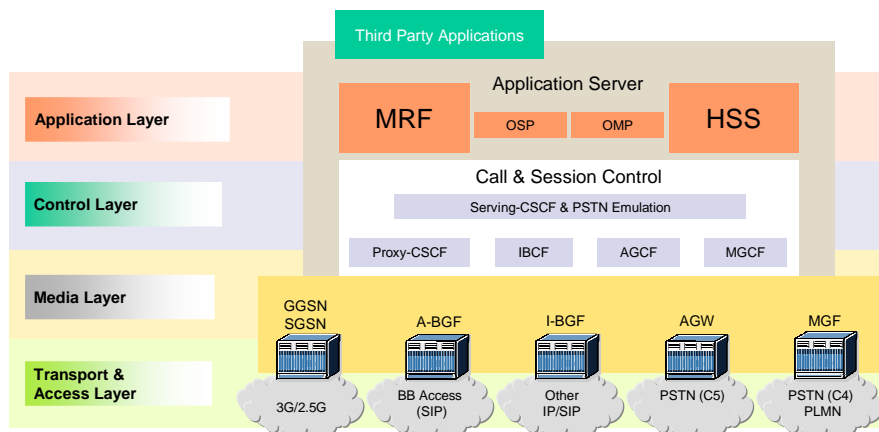



Network Architecture towards NGN IMS Architecture

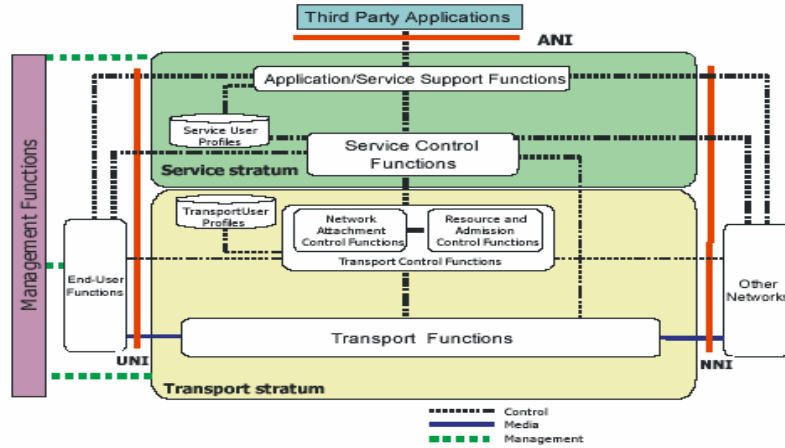

March 2007

ITU/BDT Network Architecture consolidation - O.G.S.

slide 29



Network Architecture towards NGN IMS Functional Structure and Interfaces

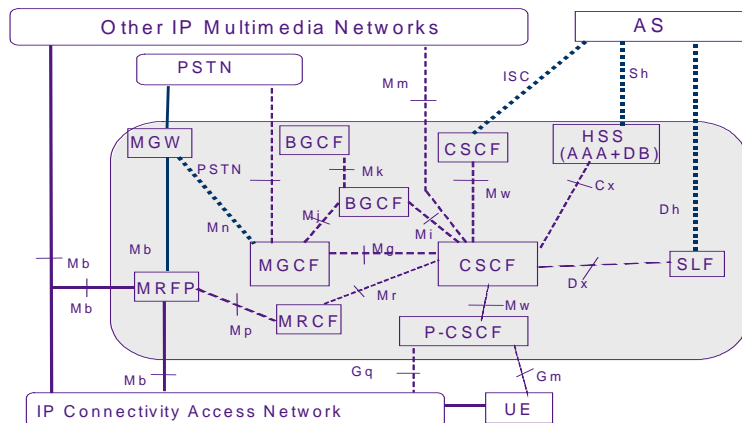

March 2007

ITU/BDT Network Architecture consolidation - O.G.S.

slide 30



Network Architecture towards NGN IMS Architecture

IMS functional elements:

- Application Server (AS)
- Home Subscriber Server (HSS)
- Call Session Control Function (CSCF)
- Breakout Gateway Control Function (BGCF)
- Media Gateway Function (MGW)
- Media Gateway Control Function (MGCF)
- Multimedia Resource Function Controller (MRFC)
- Multimedia Resource Function Processor (MRFP)



Network Architecture towards NGN IMS Architecture

Application Server (AS)

- Contains Call Related Application Logic
- Facilitates a Service Creation Environment
- Queried by S-CSCF in Real Time to Execute Logic
- Generally Specialized for Each Service
- May Provide Gateway to Legacy Applications (e.g. AIN)



Network Architecture towards NGN Evolution to IMS: Benefits



- **First advantage is the higher flexibility of the IMS functionality to adapt to the customer services**, irrespective of the technology they use and the access method to reach the network.
- **Saving in effort and time for the development and deployment** of a new service is considerably reduced once the architecture is ready at the network, implying economic savings and better Time to Market for a given service provider in a competitive market.
- **Efficient introduction on new services at a lower cost** will increase the service provider revenues and ARPU which is the major business driver for the healthy operation, market grow and financial results.
- **Higher utilization of services and better personalization** of functions to specific requirements from the end customers' point of view, a common use and feel for all services and applications



Network Architecture towards NGN Evolution to IMS: Phases

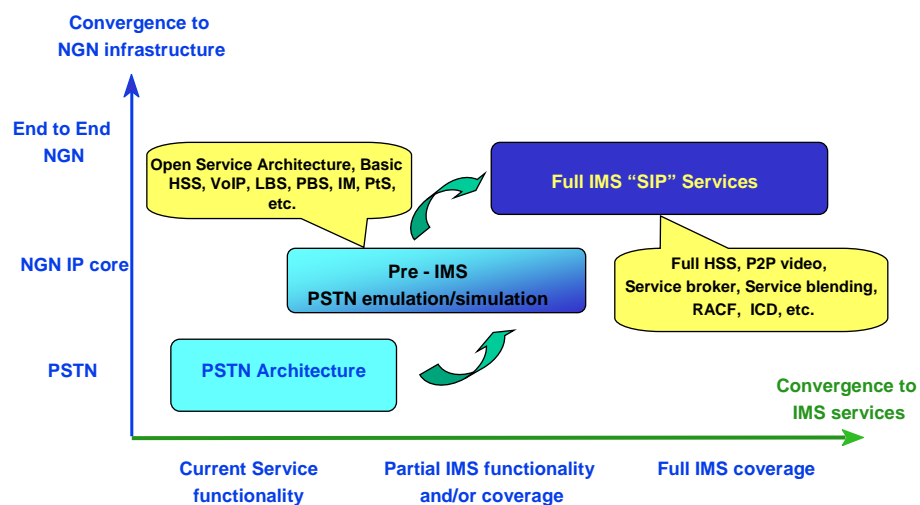



Network Architecture towards NGN Summary of Key Factors



- Plan a **phased approach** for the network migration based on business evaluation per scenario type.
- Implement **pilot cases** before network migration due to the many new technical issues.
- Consider first group of IMS services implementation to **benefit on flexibility and time to market.**