



Question 12/2: Examine broadband communications over traditional copper wires on aspects of technologies, systems and applications

STUDY GROUP 2

SOURCE: TELECOM ITALIA

TITLE: ROAD MAP OF QUESTION 12/2

1. Background

Amongst the Questions assigned to Study Group 2, Question 12/2 addresses a most promising technological area, e.g. the broadband communications/applications conveyed over the existing copper wiring by means of xDSL modems.

Due to the social benefits and business as well, which can be derived by the deployment of large band applications, with special regards to the xLDCs, Question 12/2 ought to be given high priority. This contribution attempts to provide an overview of future work.

2. Proposed Work Plan

It should be noted that the specification of the expected output span through different levels of investigation and commitment. Therefore it is suggested to split TASK N.03 /Phase 1 in sub-tasks as follows:

TASKS	LEVEL	TIMING	INPUTS/COORDINATION	NOTES
1. Description of xDSL	Technical	low/ minimum	SG15: access network, G-xDSL SG13: architecture and GII ANSI T1E1 ETSI TM6 adsl. VDSL, HDSL, DAVIC: FTCC 50Mbps ADSL Forum	xDSL technology is mature and supposed to be known. xDSL includes: very high SL, high SL, asymmetrical SL
2. Cost/benefit analysis	Technical/ economical	medium	ITU-D	
3. Assessment of demand in LDCs	Statistical/ technical/social	very high	ITU-D, regional organizations	
4. Interoperability	Technical/ economical	variable	SG13, SG15, ATM Forum	ATM, SDH, FSAN

3. xDSL Technologies (Short description)

The acronym xDSL includes a number of technologies, having a relatively mature status, developed to transmit high bandwidth (ranging from 1.5MHz to 50 MHz) over the existing copper local network. Suitable for short distances (2-6 km).

The ADSL asymmetrical digital subscriber loop provides 1.5 to 6 Mbps downstream while the upstream bit rate is as low as 64kbps. In a typical arrangement of 2Mbps downstream, ADSL line may be as far as 5 km, being subject to cable gauge. The transport capability of ADSL is up to 7 bearer channels:

- 4 simplex channel, e.g. ASo-AS3
- 3 duplex channels, e.g. Lso-LS2

The VSDL (2-50 Mbps) only allows a shorter distance such as 0.05 km - 0.5 km. This requires fibre a physical transport e.g. FTTC infrastructure to a cross-connect in the local network before conversion to copper wiring for the remainder of the connection.

It is hardly at this preliminary stage to provide substantial forecast; however, according to a number of surveys the following 1997 estimation depicts the ADSL trends:

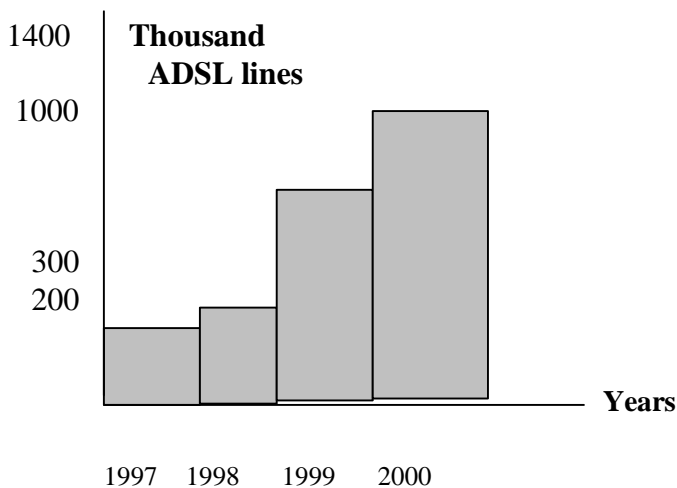

Rough estimation of No of ADSL connection up to Year 2000 Based on 1997 forecasts

Obviously, a detailed investigation is to be carried out within Question 12/2, this being a fundamental issue in the process of the assessment of the demand.

Since interoperability is equally important with a view to future integration some initial architectural scenarios are reproduced for easy reference as follows:

4. Reference home to Telco ADSL/access network

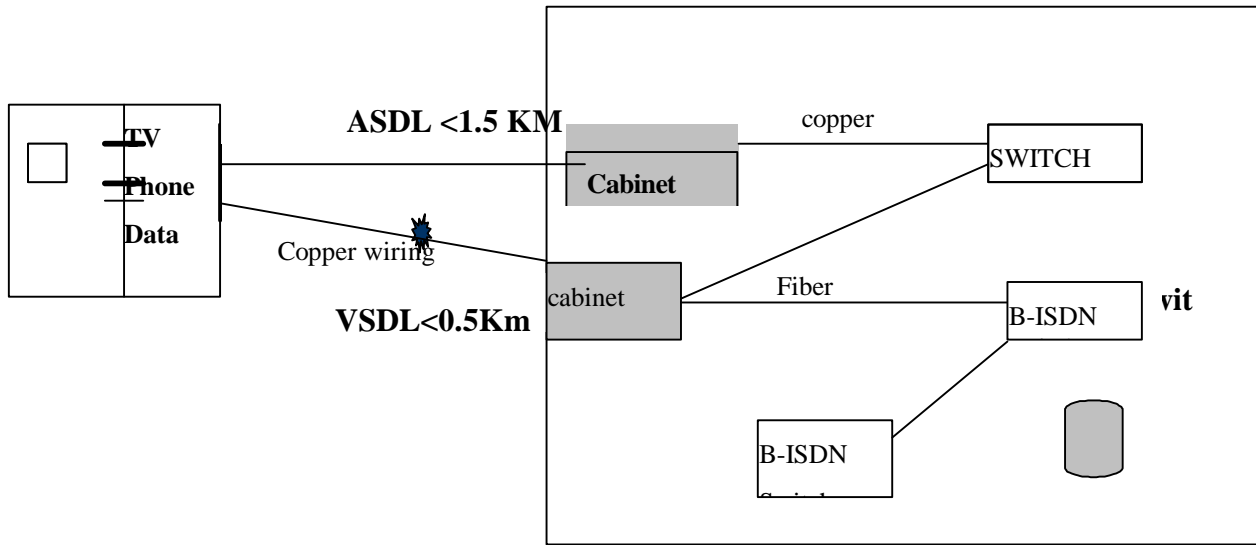

Note: This scenario is for easy reference only.

5. The transport in the Access network

The access network is a primarily issue to understand the ADSL technology. It includes the functional process of transferring information across different points. In respect of Question 12/2 it would be beneficial to be aware of ongoing ITU standards, e.g.

- Subscriber line systems G.xDSL
- Data Communication over the PSTN V-Series
- G.xDSL Spectrum:

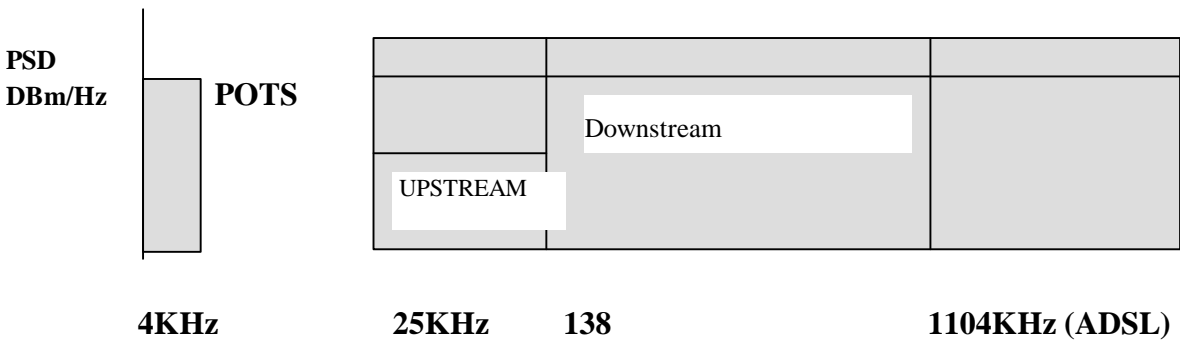

6. Status of transport in the access network standardization activity

Access	Media	Bandwidth	Body	Status
Baseband	Paired cable	Speech/data	ITU-T	complete
N-ISDN	Paired cable	<"2048 Kbps	ITU-T	complete
B-ISDN	Coax, Fibre, HFC	<622 Mbps-STM1	ITU-T	complete
xDSL	Paired cable, HFC	0.5 – several Mbps	ITU, ETSI, ANSI, ADSLF, ATMF, DAVIC	ongoing
Passive optical	Fibre	>primary rate	ITU-T	complete
Fixed wireless	Radio spectrum	High speed	ITU-R, Davic	ongoing
Mobile	Radio spectrum	Low speed	ITU-R, ETSI	ongoing

7. Other relevant issues of investigation: ISDN Users

- Voiceband Telephone are at 3.1 KHz frequency. For ISDN the portion of the spectrum used is up to 70 kHz. Frequencies above this (up to 1.1 MHz) are available for ADSL. This implies that ISDN over ASDL on one line may not be achieved so simply since the ASDL standards address 25 kHz to 1.1 MHz. Three questions, therefore, need to be addressed when the two signals are combined:
 - 1) Whether this decrease in ADSL bandwidth (over 70 MHz vs > 25MHz) limits its performance;
 - 2) ADSL needs the low end of the spectrum to generate start-up signals that serve as a "handshake" to negotiate the details of the connection.
 - 3) It should be assured in any case that the ISDN and ASDL signals will not reciprocally interfere.
- Electromagnetic interference from other services on same cable
- Client layer adaption into xDSL server layer
- Boundary between user and network Operators.

Since:

- 1) Standardization activity on transport is scattered
 - 2) There exist a large variety of standards, e.g. B-ISDN, CATV, xDSL, power lines
- Convergency of standards, industry activity, entertainment is sought, e.g. the GII is supposed to fit the ITU-D Study Group programme in the longer terms.
