



***Regional Seminar on New Trends in Tariff
Policies for CEE Countries & CIS***

BDT

Bratislava, Slovakia 18 – 20 September, 2001

Interconnection, USO, Competition

**Interconnection, universal service obligations,
new technologies and competition**

Pape Gorgui TOURE
Head, Financing Strategies Unit
BDT/PSF
pape-gorgui.toure@itu.int

Note - The views expressed in this presentation are those of the author and do not necessarily reflect those of ITU or its membership.



The purpose of interconnection

BDT

Interconnection, USO, Competition

- The cost of interconnection is calculated to determine either the sale price of one minute of a given service (e.g. simple transit terminal traffic), or the fee for use of an infrastructure (e.g. a local loop).
- In the first case the rate is set for a customer-service and in the second for a network-service.
- Collocation services are also included.



Interconnection points

BDT

- Two networks can be interconnected at different levels:

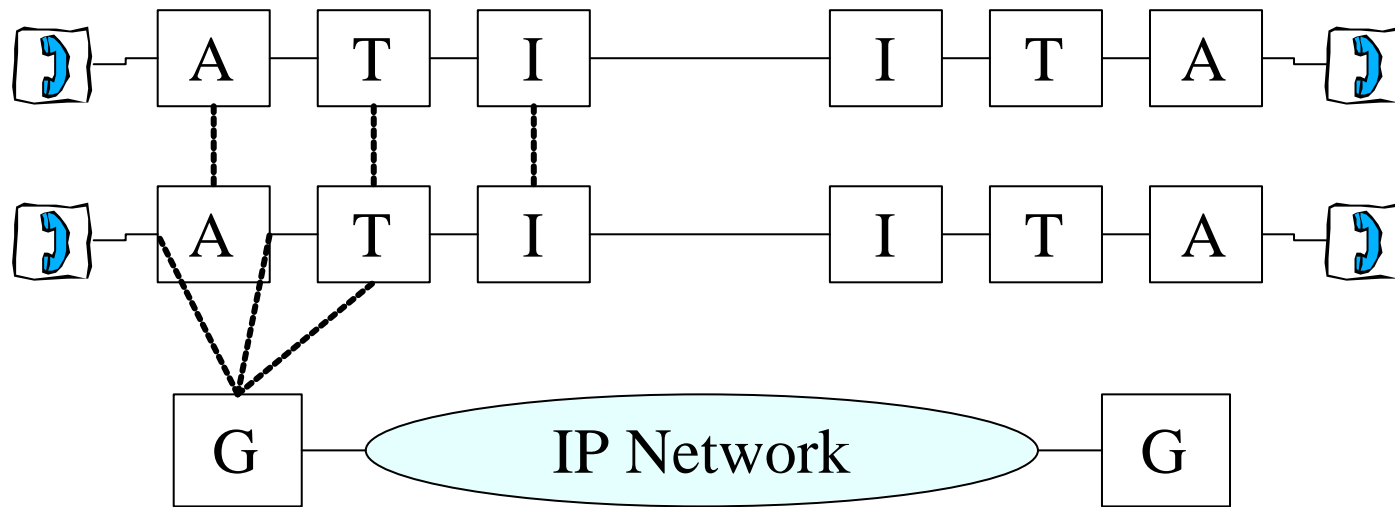

Interconnection, USO, Competition

- The costs of interconnection depend on the point of interconnection.
- Access to customers by broadband service providers via IP networks gives rise to new questions.



Interconnection issues

BDT

Interconnection, USO, Competition

- Interconnection issues should be considered within the context of convergent multiservice networks:
 - *What are the relevant costs?*
 - *What method should be used to determine the customer service or network service share of the total indirect costs of depreciation and operation of convergent networks?*
 - *How are common costs to be distributed?*
 - *How will the access deficit be determined and what services should if necessary be financed?*



The separation of accounts

BDT

Interconnection, USO, Competition

- Depending on the interconnection point, interconnection tariffs may or may not include the following cost elements:
 - *network access*
 - *network backbone*
 - *retail activities*
 - *other activities*
- The aim is to manage each element as though it were an independent business activity.



Relevant costs

BDT

Interconnection, USO, Competition

- The following costs should be taken into account when calculating interconnection tariffs:
 - *direct costs*
 - *indirect costs*
 - *common costs*
 - *capital costs*
 - *tax on turnover or earnings*
 - *the cost some of universal service obligations*



Nature of the costs

BDT

Interconnection, USO, Competition

- The direct and indirect costs include depreciation, operating and maintenance costs and sales-related costs.
- Common costs are those generally incurred by the company for leadership and management purposes (e.g. DG, finance, HR, MIS).
- The cost of capital will depend on the capital market and the assessment of risks of all kinds.
- The costs of universal service obligations arise naturally from the constraints that are often related to the choice of investment and the tariff ceilings that a State can impose on a service provider.



Methods of allocating costs to services

BDT

Interconnection, USO, Competition

- Infrastructure costs are distributed among customer services on the basis of traffic; as a rule, two concepts are used:
 - *distribution by average incremental costs (avoidable costs) (AIC);*
 - *distribution by fully distributed costs (FDC).*
- The costs of infrastructure cannot be allocated to network-services on the basis of average incremental costs. This leaves two options: either they are considered to have zero incidence on customer services, or they are allocated to those services as a function of usage (volume of traffic).
- To distribute other costs, the method known as activity-based costing (ABC) has given satisfactory results.



Allocating the costs of universal service obligations

BDT

Interconnection, USO, Competition

- The cost of universal service obligations is an income shortfall resulting from a State decision and has two components:
 - *the cost of social measures aimed at specific target groups to which positive discrimination is applied (e.g. the disabled, the unemployed);*
 - *the access deficit, which measures the gap between the tariff ceilings imposed on domestic services (in general) and the tariffs calculated on the basis of cost.*
- The cost of the social measures should be financed by a fund to which all involved parties contribute.
- The cost of access deficit should be equitably redistributed among the services not subject to the constraints and included in their base tariffs.



Allocating the costs of universal service obligations (continued)

BDT

Interconnection, USO, Competition

- The effect of the access deficit on interconnection tariffs guarantees the transparent and non-discriminatory participation of all operators using the network, and hence free and fair competition.
- Since the cost per unit of traffic naturally tends to fall as traffic increases, the access deficit should gradually decrease (tariff rebalancing) and disappear altogether in a totally competitive market.



Interconnection and IP networks

BDT

Interconnection, USO, Competition

- Interconnectivity and interoperability are *sine qua non* conditions for interconnection.
- In the transitional stage during which connection based networks exist alongside connectionless networks, the incoming international traffic of operators of connection based networks could drop sharply. During the same period, the increase in the volume of incoming traffic from IP networks will be a source of extra income, *provided that VoIP operators are deemed to be on the same footing as all others and interconnect to the voice network under the same conditions as the others.*



Interconnection to the access network

BDT

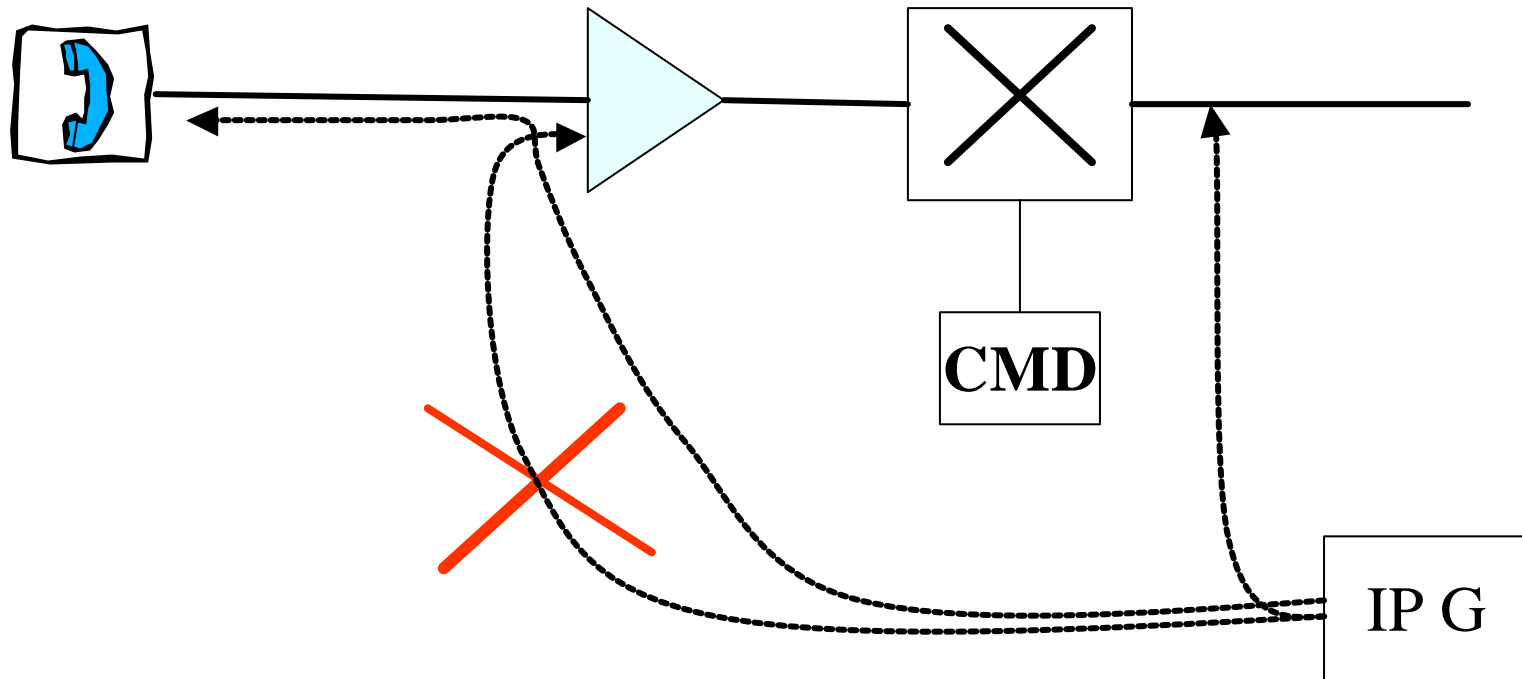

Interconnection, USO, Competition

- Simple resale is not a viable mode of interconnection.
- Interconnection to the access network via interexchange circuits limits the service provided to telephony.
- Interconnection via the local loop opens up a wide range of possibilities.



Development of the VoX market

BDT

Interconnection, USO, Competition

- The voice on data networks market will increase from USD 2 billion in 1998 to USD 25 billion in 2002, or 20% of the overall market.
- This development will lead to strong growth in the use of xDSL, the number of which will rise from 2 million in 2000 to 20 million in 2002.



BDT

Interconnection, USO, Competition

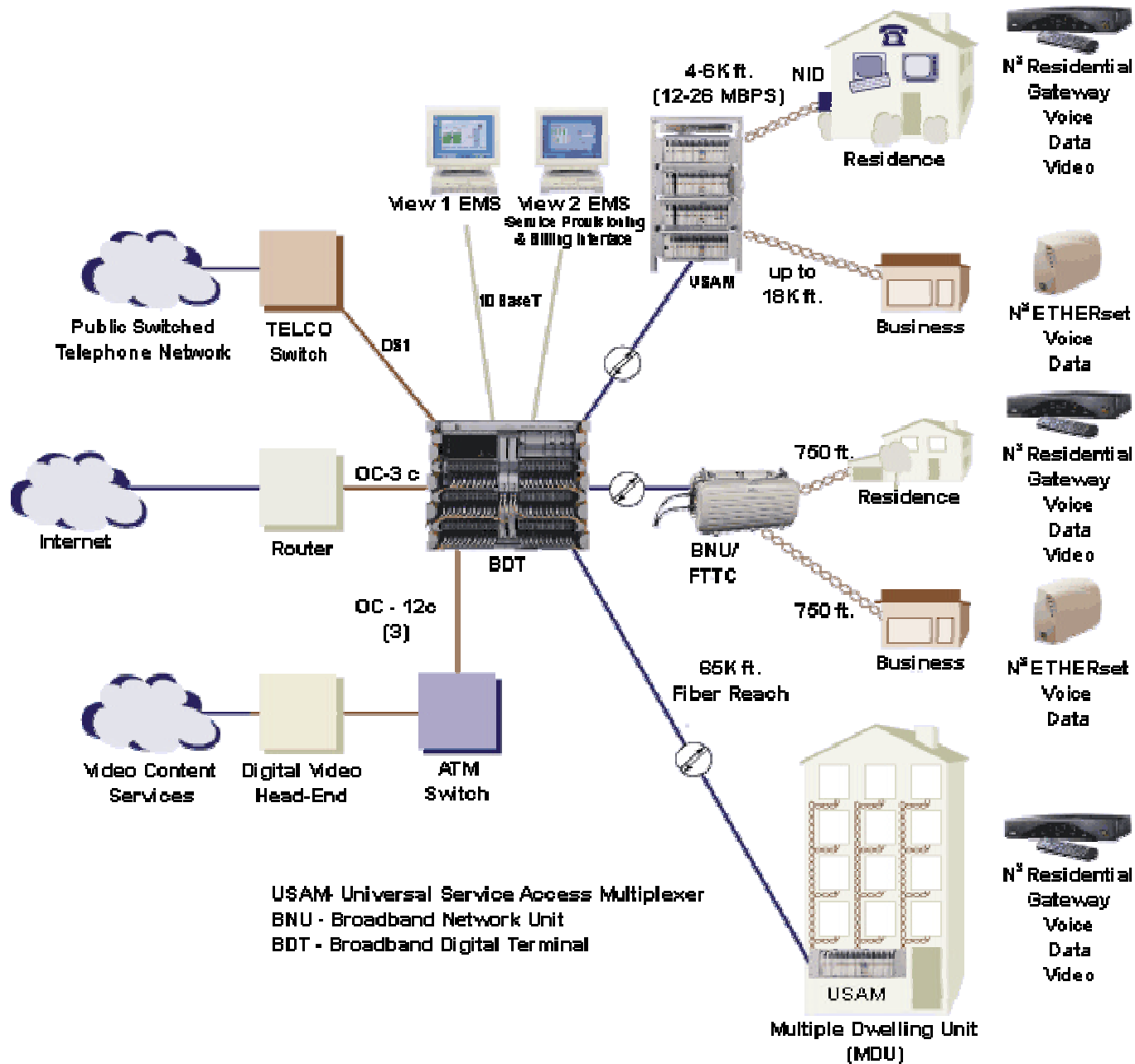



Interconnection and IP networks (continued)

BDT

Interconnection, USO, Competition

- IP network operators may wish to have direct access to the customers of connection-based network operators in order to offer them multimedia services ranging from simple telephony to images in motion using the wired network.
- In this case the problem of interconnection comes down to selling a network-service and includes:
 - *the unbundling of access network costs;*
 - *the offer of the xDSL service.*



Sharing the local loop

BDT

Interconnection, USO, Competition

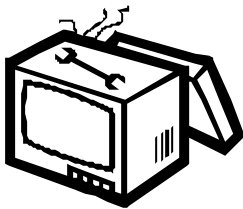
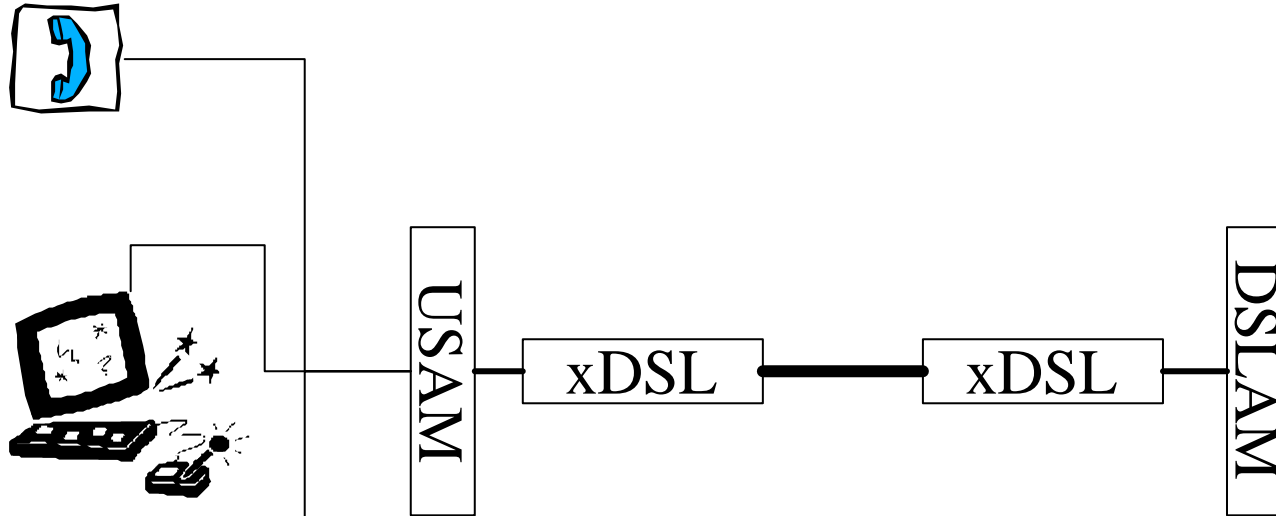

Domestic gateway

- By using xDSL, high-speed services can be offered on the copper cables of conventional networks.
- This opens a new range of possibilities for interconnection in terms of cost separation and collocation.



Interconnection and IP networks (continued)

BDT

Interconnection, USO, Competition

- Once connectionless-networks have become commonplace, they will probably use IP-encapsulating ATM in their Network Access Points (NAP).
- The arrangements currently used for interconnecting Internet backbones are *peering* and *transit*. These are commercial agreements based respectively on Sender Keeps All and simple resale.
- If those arrangements are maintained for connectionless-networks, the interconnection arrangements as they exist today will disappear, leaving the risk of fragmentation of service provision.



Interconnection and IP networks (continued)

BDT

Interconnection, USO, Competition

- However, since fragmentation is not in the economic interests of operators, it will not be long before the cost-based interconnection returns; but in the interval, small operators could be eliminated if they are not protected by regulations.
- On the other hand, the other current system of international accounting (D.150) will disappear with the notion of international communication.
- Recommendation D.224 provides the measurement tools required to manage the interconnection of ATM-based networks.