

ITU/BDT Arab Regional Workshop on “4G Wireless Systems” LTE Technology

Session 6 : LTE/SAE Mobility and Session Managment

Speakers	M. Lazhar BELHOUCHE M. Hakim EBDELLI
Date	27 – 29 January 2010

Agenda

- LTE/SAE Mobility Areas
- Tracking Areas
- UE Identifications
- LTE Mobility & Connection States
- EPS Connection Management (ECM) and LTE Radio Resource Control States
- RRC States
- LTE/SAE Bearer

LTE/SAE Mobility Areas

- Two areas are defined for handling of mobility in LTE/SAE:
- The Cell
 - identified by the Cell Identity.
- Tracking Area (TA)
 - It is the successor of location and routing areas from 2G/3G.
 - When a UE is attached to the network, the MME will know the UE's position on tracking area level.
 - In case the UE has to be paged, this will be done in the full tracking area.
 - Tracking areas are identified by a Tracking Area Identity (TAI).

Tracking Areas

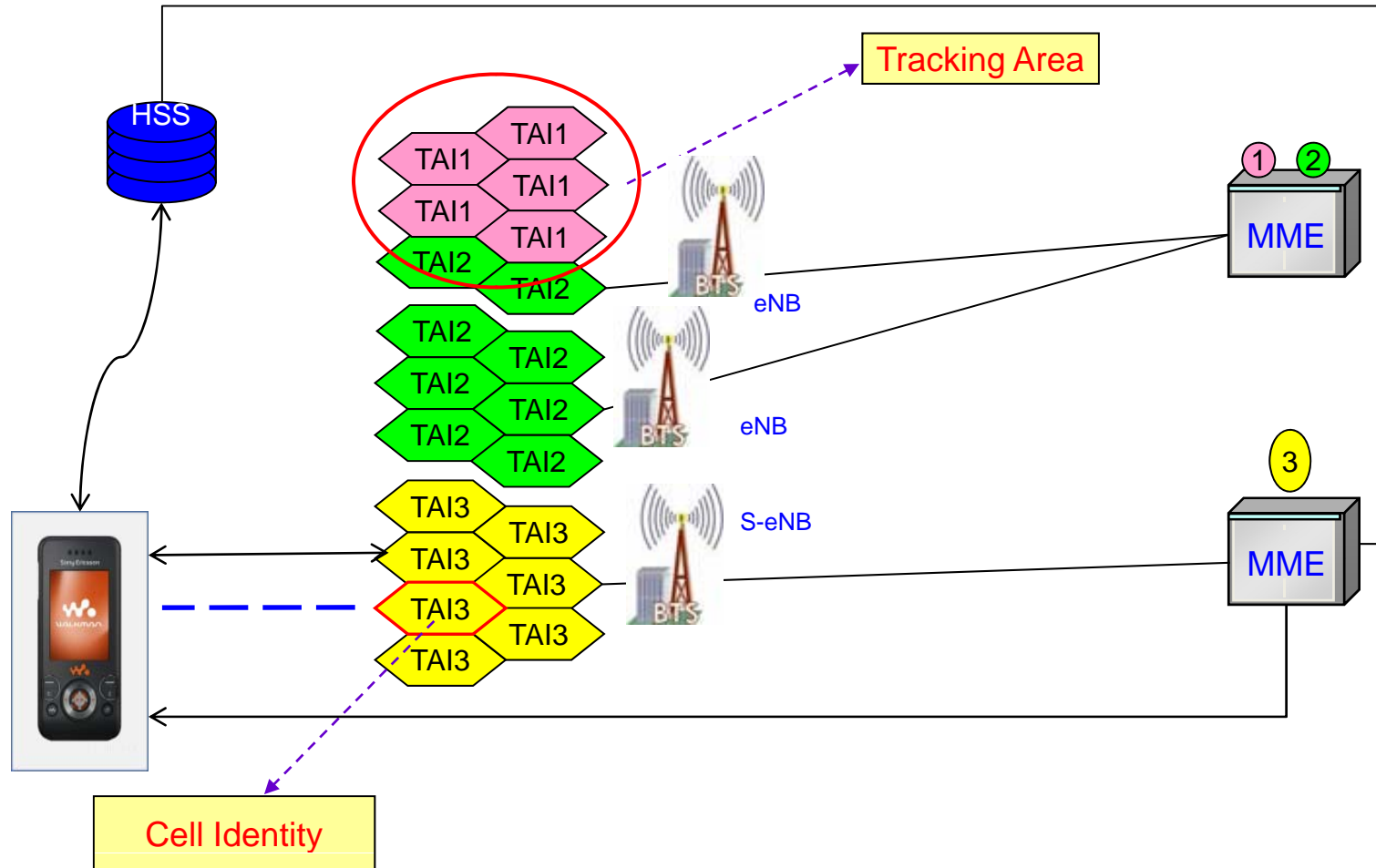

Tracking Areas: Use of S1-flex Interface

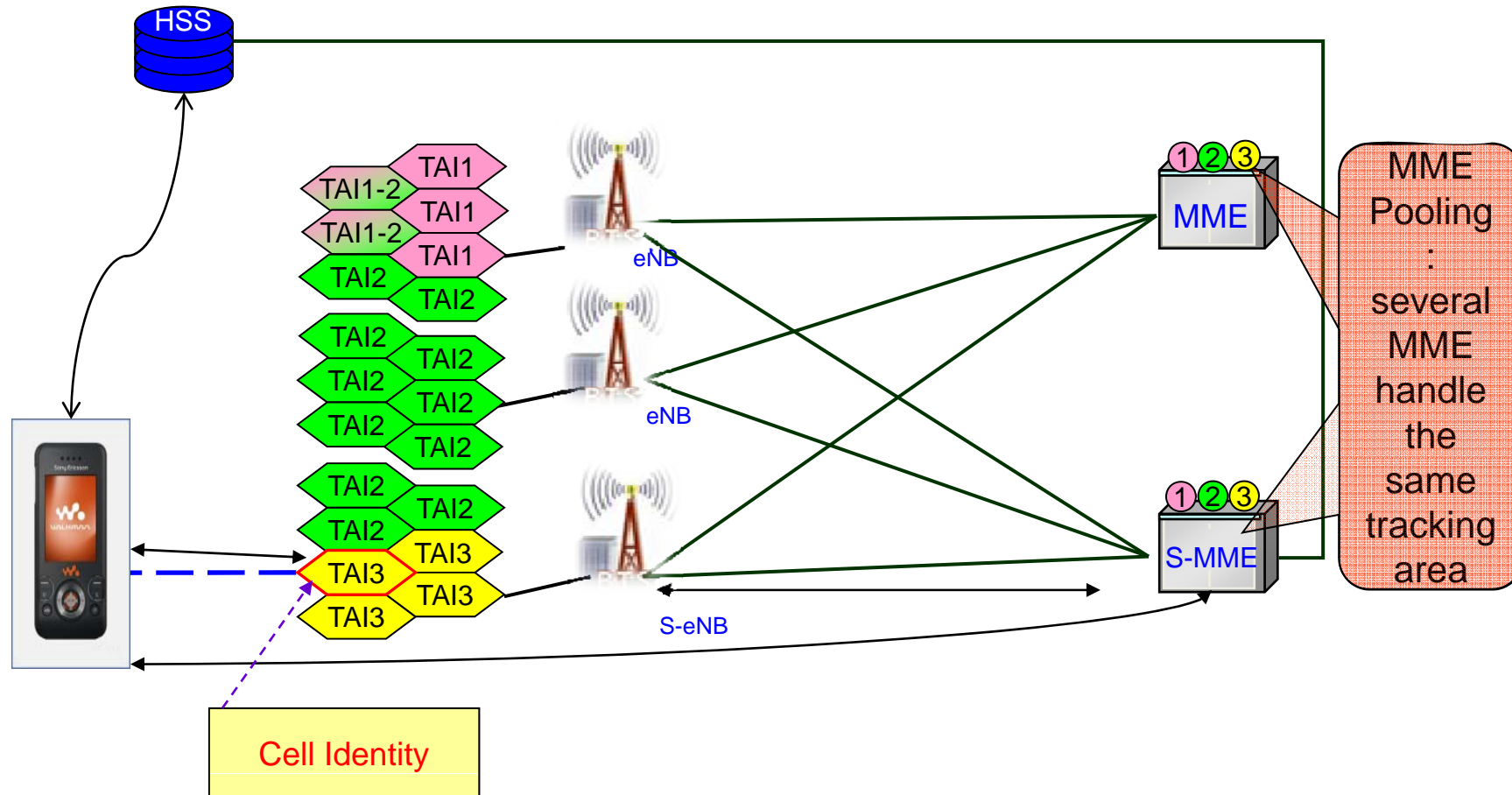

UE Identifications

- IMSI
 - International Mobile Subscriber Identity
- S-TMSI
 - SAE Temporary Mobile Subscriber Identity
- C-RNTI
 - Cell Radio Network Temporary Identity
- S1-AP UE ID
 - S1 Application Protocol User Equipment Identity



UE Identifications: IMSI

- IMSI: International Mobile Subscriber Identity.
- Used in SAE to uniquely identify a subscriber world-wide.
- Its structure is kept in form of MCC+MNC+MSIN:
 - MCC: mobile country code
 - MNC: mobile network code
 - MSIN: mobile subscriber identification number
- A subscriber can use the same IMSI for 2G, 3G and SAE access.
- MME uses the IMSI to locate the HSS holding the subscribers permanent registration data for tracking area updates and attaches.

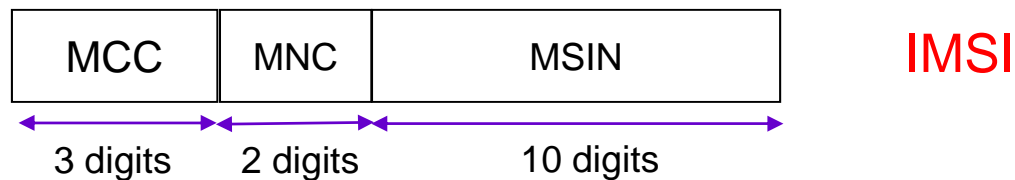

UE Identification: S-TMSI

- S-TMSI: SAE Temporary Mobile Subscriber Identity
- It is dynamically allocated by the serving MME (S-MME).
- Its main purpose is to avoid usage of IMSI on air.
- Internally the allocating MME can translate S-TMSI into IMSI and vice versa.
- Whether the S-TMSI is unique per MME or per TA is not clear yet.
- In case the S1 flex interface option is used, then the eNB must select the right MME for a UE. This is done by using some bits of the S-TMSI to identify the serving MME of the UE. This identifier might be a unique MME ID or a form of MME color code. Under investigation.



UE Identifications: C-RNTI

- C-RNTI: Cell Radio Network Temporary Identity
- C-RNTI is allocated by the eNB serving a UE when it is in active mode (RRC_CONNECTED)
- This is a temporary identity for the user only valid within the serving cell of the UE.
- It is exclusively used for radio management procedures.
- X-RNTI identifications under investigation.

UE Identifications:S1-AP UE ID

- S1-AP UE ID: S1 Application Protocol User Equipment Identity.
- Two additional temporary identifiers allocated by eNB and MME:
 - eNB S1-AP UE ID
 - MME S1-AP IE ID
- Their purpose is to allow efficient implementation of S1 control signaling (S1AP=S1 Application Protocol)
- They shall allow easy distribution of S1 signaling messages inside MME and eNB.
- NOTE: This concept is similar to SCCP local references known from Iu or A interface in 3G/2G.

UE Identifications Summary

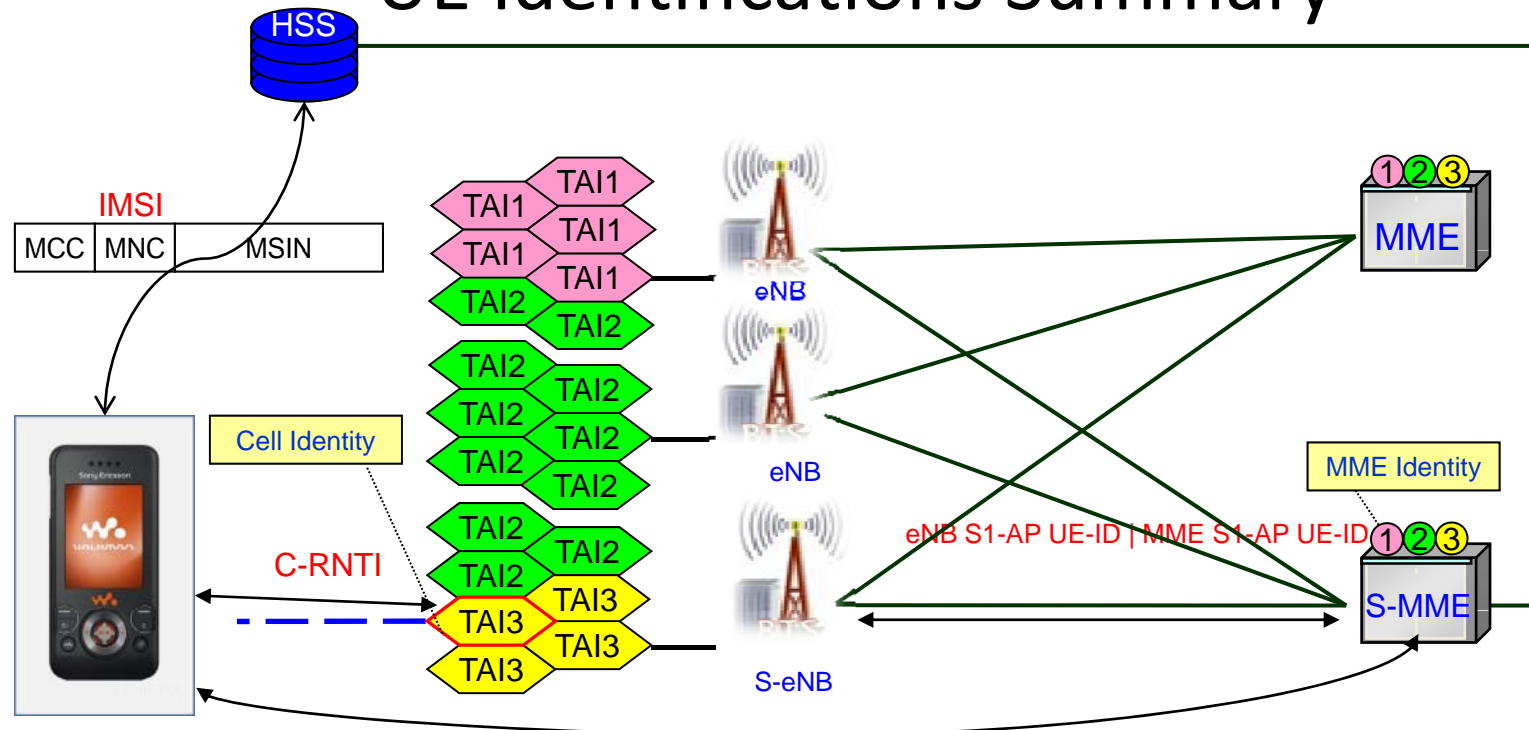

- IMSI International Mobile Subscriber Identity
- S-TMSI S-Temporary Mobile Subscriber Identity
- C-RNTI Cell Radio Network Temporary Identity
- S-MME Serving MME
- S-eNB Serving E-Node B
- TAI Tracking Area Identity (MCC+MNC+TAC)

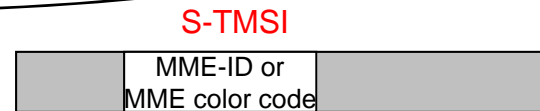

Terminology for 3G & LTE: Connection & Mobility Management

3G	LTE
Connection management	
GPRS attached	EMM registered
PDP context	EPS bearer
Radio access bearer	Radio bearer + S1 bearer
Mobility management	
Location area	Not relevant (no CS core)
Routing area	Tracking area
Handovers (DCH) and cell reselections (PCH) when RRC connected	Handovers when RRC connected
RNC hides mobility from core network	Core network sees every handover

LTE Mobility & Connection States

- There are two sets of states defined for the UE based on the information held by the MME.
- These are:
 - 1.EPS* Mobility Management (EMM) states
 - 2.EPS* Connection Management (ECM) states

EPS Mobility Management (EMM) states

EMM-DEREGISTERED:

In this state the MME holds no valid location information about the UE
MME may keep some UE context when the UE moves to this state (e.g. to avoid the need for Authentication and Key Agreement (AKA) during every attach procedure)

Successful Attach and Tracking Area Update (TAU) procedures lead to transition to EMM-REGISTERED

EMM-REGISTERED:

In this state the MME holds location information for the UE at least to the accuracy of a tracking area

In this state the UE performs TAU procedures, responds to paging messages and performs the service request procedure if there is uplink data to be sent.

EPS Mobility Management (EMM) states

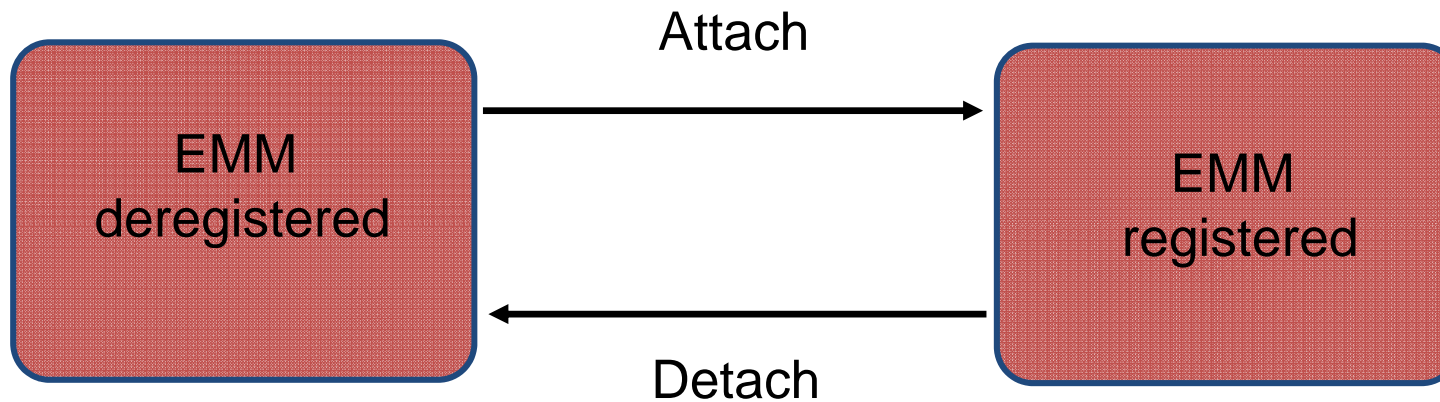

EPS Connection Management (ECM) and LTE Radio Resource Control States

UE and MME enter ECM-CONNECTED state when the signaling connection is established between UE and MME

UE and E-UTRAN enter RRC-CONNECTED state when the signaling connection is established between UE and E-UTRAN

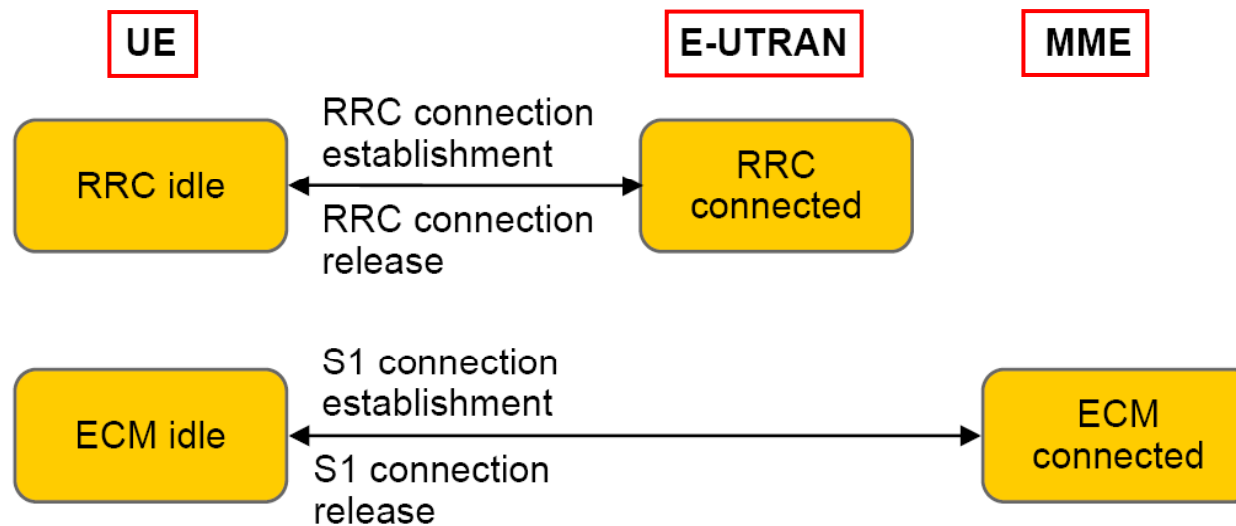

EPS Connection Management (ECM) states

ECM-IDLE:

In this state there is no NAS signaling connection between the UE and the network and there is no context for the UE held in the E-UTRAN.

The location of the UE is known to within the accuracy of a tracking area
Mobility is managed by tracking area updates.

ECM-CONNECTED:

In this state there is a signaling connection between the UE and the MME which is provided in the form of a Radio Resource Control (RRC) connection between the UE and the E-UTRAN and an S1 connection for the UE between the E-UTRAN and the MME.

The location of the UE is known to within the accuracy of a cell.
Mobility is managed by handovers.

RRC States

- RRC_IDLE:
 - No signalling connection between the UE and the E-UTRAN.
 - I.e.: PLMN Selection.
 - UE Receives system information and listens for Paging.
 - Mobility based on Cell Re-selection performed by UE.
 - No RRC context stored in the eNB.
 - RACH procedure used on RRC connection establishment.
- RRC_CONNECTED:
 - UE has an E-UTRAN RRC connection.
 - UE has context in E-UTRAN (C-RNTI allocated).
 - E-UTRAN knows the cell which the UE belongs to.
 - Network can transmit and/or receive data to/from UE.
 - Mobility based on handovers
 - UE reports neighbour cell measurements

EPS Connection Management

ECM Connected= RRC Connected + S1 Connection

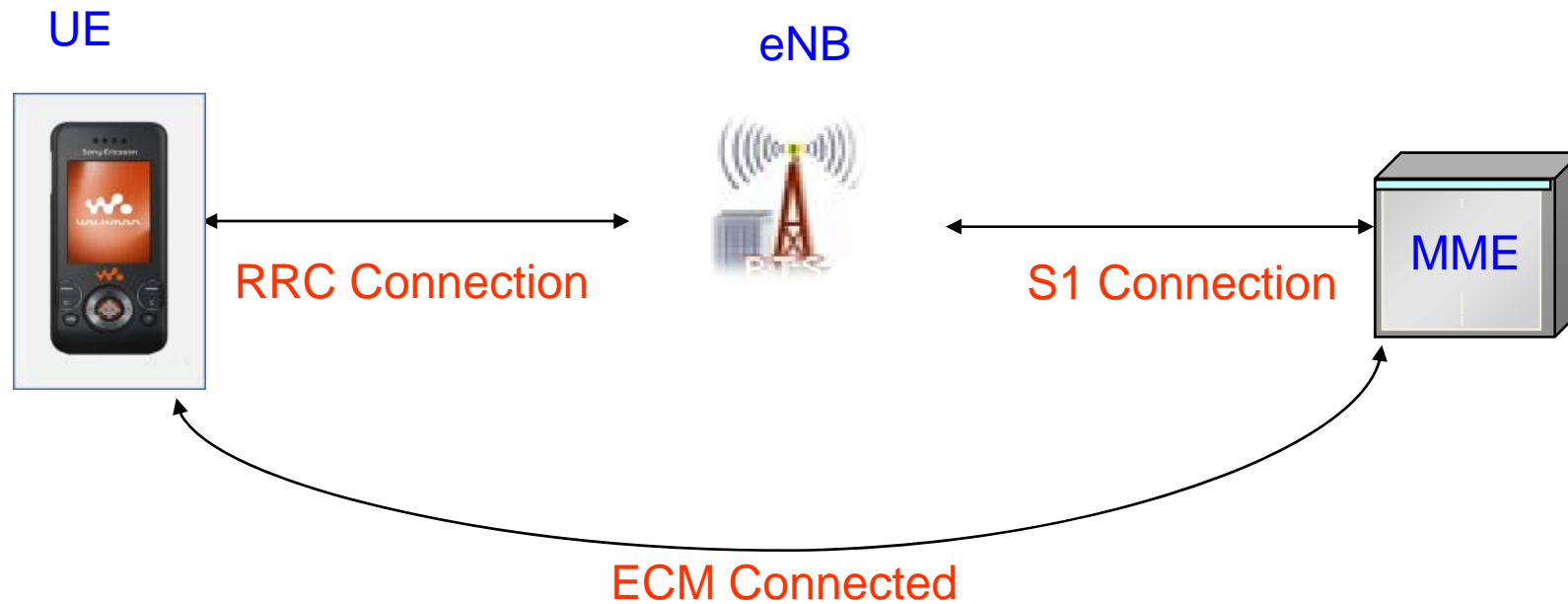

EMM & ECM States Transitions

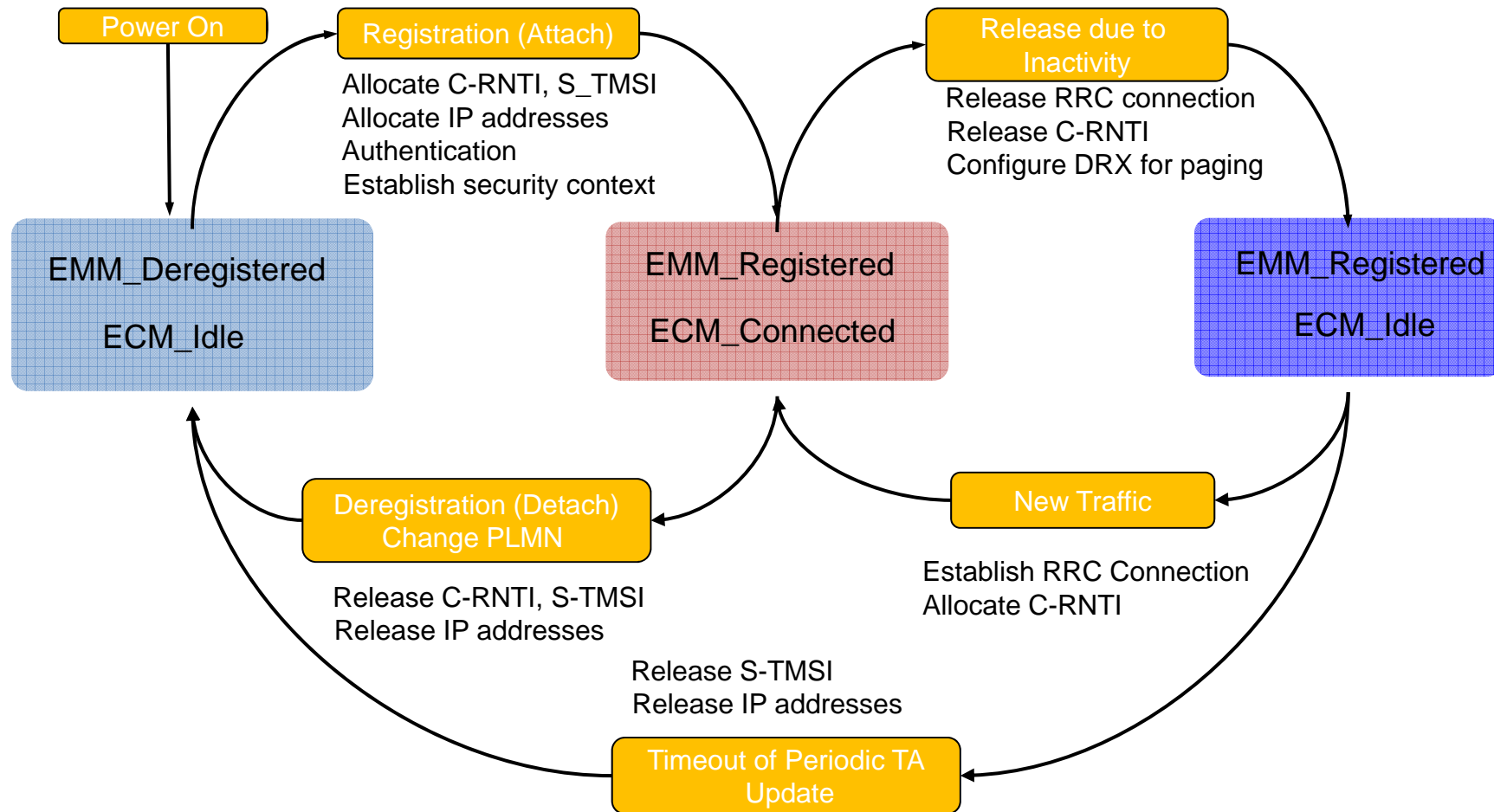

EMM & ECM States Summary

EMM_Deregistered ECM_Idle

Network Context:
no context exists

Allocated IDs:
IMSI

UE Position:
unknown to network

Mobility:
PLMN/cell selection

UE Radio Activity: none

EMM_Registered ECM_Connected

Network Context:
all info for ongoing
transmission/reception

Allocated IDs:
IMSI, S-TMSI per TAI
1 or several IP addresses
C-RNTI

UE Position:
known on cell level

Mobility:
NW controlled handover

UE Radio Activity:
DL w/o DRX
UL w/o DTX

EMM_Registered ECM_Idle

Network Context:
security keys
enable fast transition to
ECM_CONNECTED

Allocated IDs:
IMSI, S-TMSI per TAI
1 or several IP addresses

UE Position:
known on TA level (TA list)

Mobility:
cell reselection

UE Radio Activity:
DL DRX for paging
no UL

LTE/SAE Bearer

- The main function of every mobile radio telecommunication network is to provide subscribers with transport bearers for their user data.
- In circuit switched networks users get a fixed assigned portion of the network's bandwidth.
- In packet networks users get a bearer with a certain quality of service (QoS) ranging from fixed guaranteed bandwidth down to best effort services without any guarantee.
- LTE/SAE is a packet oriented system

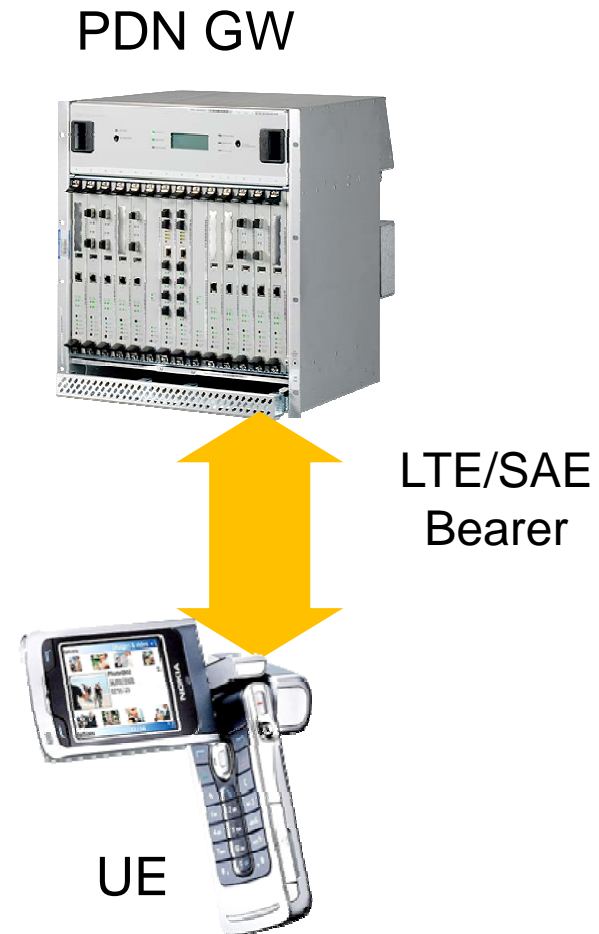

SAE Bearer Architecture

SAE Bearer spans the complete network, from UE over EUTRAN and EPS up to the connector of the external PDN.

The SAE bearer is associated with a quality of service (QoS) usually expressed by a label or QoS Class Identifier (QCI).

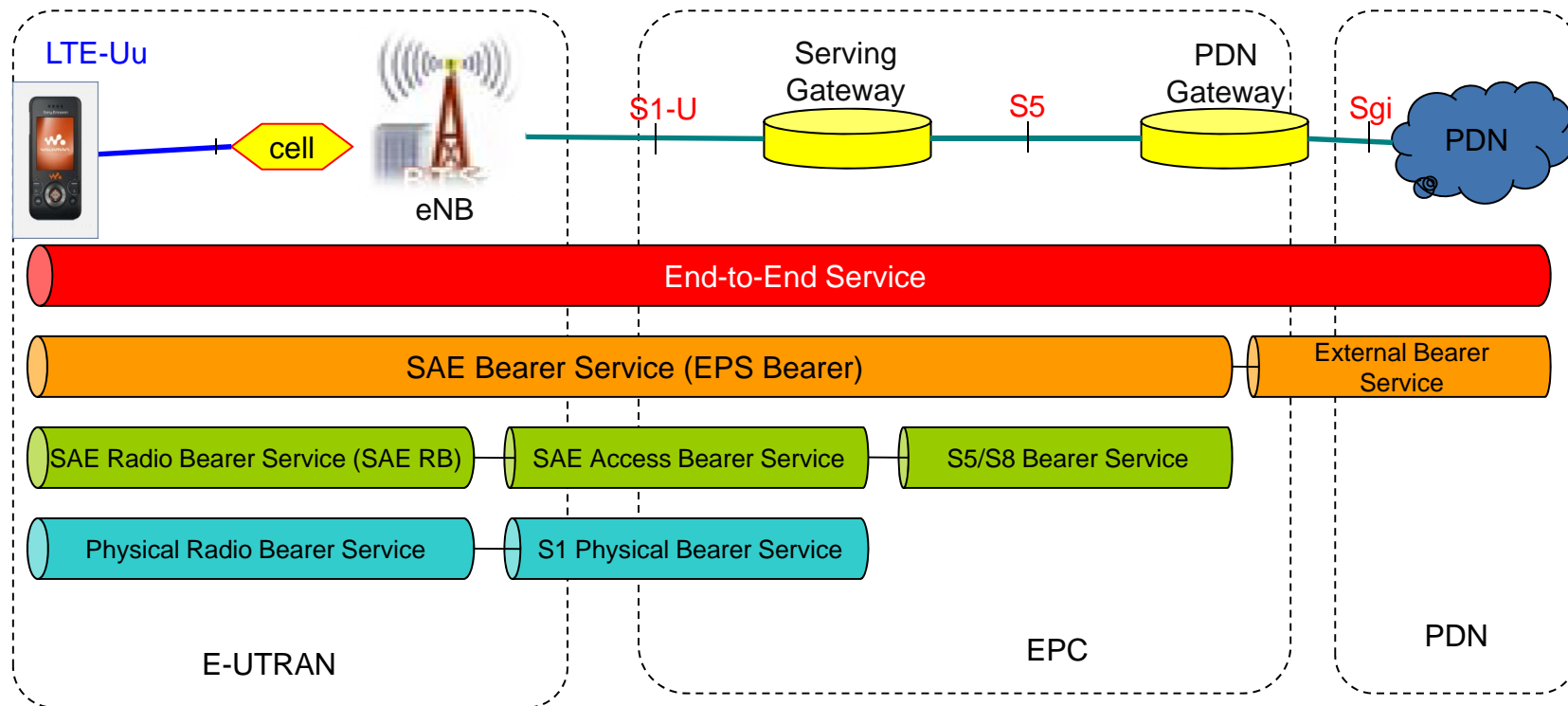

SAE Bearer Sections

- S5/S8 bearer
 - Between the PDN GW and SAE GW.
 - This is usually a GTP or MIP tunnel between the two network elements.
- SAE Access Bearer Between eNB and SAE GW.
 - The SAE Access Bearer is implemented using the 2G/3G GTP protocol which builds a GTP tunnel between eNB and SAE GW.
 - The setup of this SAE Access Bearer is managed by the MME.
 - SAE GW and eNB do not directly exchange signaling to create it.
- Radio bearers Between UE and eNB.
 - The eNB connects a radio bearer internally with the associated SAE access bearer on S1-U interface.
 - The mapping of radio bearers to physical resources on the air interface is the major task of the eNB scheduler.

Thanks for your Attention